

Operator's Manual

EX60-5

EX60LC-5

Excavator

CLICK HERE TO **DOWNLOAD** THE COMPLETE MANUAL

- Thank you very much for reading the preview of the manual.
- You can download the complete manual from: www.heydownloads.com by clicking the link below



- Please note: If there is no response to CLICKING the link, please download this PDF first and then click on it.

CLICK HERE TO **DOWNLOAD** THE COMPLETE MANUAL

SAFETY

RECOGNIZE SAFETY INFORMATION

- This is the **SAFETY ALERT SYMBOL**.
 - When you see this symbol on your machine or in this manual, be alert to the potential for personal injury.
 - Follow recommended precautions and safe operating practices.



SA-001

001-E01A-0001

UNDERSTAND SIGNAL WORDS

- On machine safety signs, signal words designating the degree or level of hazard - **DANGER**, **WARNING**, or **CAUTION** - are used with the safety alert symbol.
 - **DANGER** indicates an imminently hazardous situation which, if not avoided, will result in death or serious injury.
 - **WARNING** indicates a potentially hazardous situation which, if not avoided, could result in death or serious injury.
 - **CAUTION** indicates a potentially hazardous situation which, if not avoided, may result in minor or moderate injury.
 - **DANGER** or **WARNING** safety signs are located near specific hazards. General precautions are listed on **CAUTION** safety signs.
- **CAUTION** also calls attention to safety messages in this manual.
- To avoid confusing machine protection with personal safety messages, a signal word **IMPORTANT** indicates a situation which, if not avoided, could result in damage to the machine.
-  **NOTE** indicates an additional explanation for an element of information.



IMPORTANT



SA-1223

002-E01A-1223

SAFETY

AVOID INJURY FROM BACK-OVER AND SWING ACCIDENTS

- If any person is present near the machine when backing or swinging the upperstructure, the machine may hit or run over that person, resulting in serious injury or death.

To avoid back-over and swing accidents:

- Always look around **BEFORE YOU BACK UP AND SWING THE MACHINE. BE SURE THAT ALL BYSTANDERS ARE CLEAR.**
- Keep the travel alarm in working condition (if equipped).
ALWAYS BE ALERT FOR BYSTANDERS MOVING INTO THE WORK AREA. USE THE HORN OR OTHER SIGNAL TO WARN BYSTANDERS BEFORE MOVING MACHINE.
- **USE A SIGNAL PERSON WHEN BACKING UP IF YOUR VIEW IS OBSTRUCTED. ALWAYS KEEP THE SIGNAL PERSON IN VIEW.**
Use hand signals, which conform to your local regulations, when work conditions require a signal person.
- No machine motions shall be made unless signals are clearly understood by both signalman and operator.
- Learn the meanings of all flags, signs, and markings used on the job and confirm who has the responsibility for signaling.
- Keep windows, mirrors, and lights clean and in good condition.
- Dust, heavy rain, fog, etc., can reduce visibility. As visibility decreases, reduce speed and use proper lighting.
- Read and understand all operating instructions in the operator's manual.

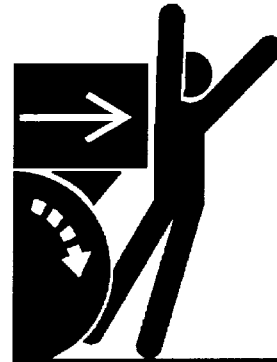

SA-383

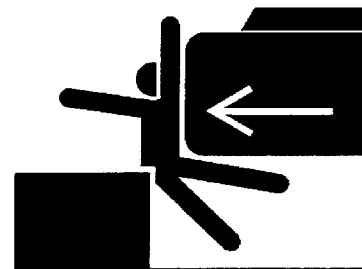

SA-384

021-E01A-0494

SAFETY

PREVENT PARTS FROM FLYING

- Grease in the track adjuster is under high pressure. Failure to follow the precautions below may result in serious injury, blindness, or death.
 - Do not attempt to remove GREASE FITTING or VALVE ASSEMBLY.
 - As pieces may fly off, be sure to keep body and face away from valve.
- Travel reduction gears are under pressure.
 - As pieces may fly off, be sure to keep body and face away from AIR RELEASE PLUG to avoid injury. GEAR OIL is hot.
 - Wait for GEAR OIL to cool, then gradually loosen AIR RELEASE PLUG to release pressure.



SA-344

503-E01B-0344

STORE ATTACHMENTS SAFELY

- Stored attachments such as buckets, hydraulic hammers, and blades can fall and cause serious injury or death.
 - Securely store attachments and implements to prevent falling. Keep children and bystanders away from storage areas.

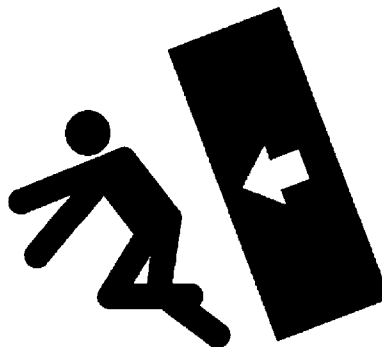

SA-034

504-E01A-0034

SAFETY SIGNS



SS-408

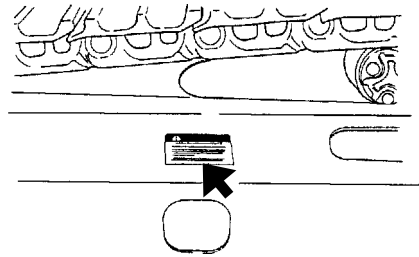

SS-1113

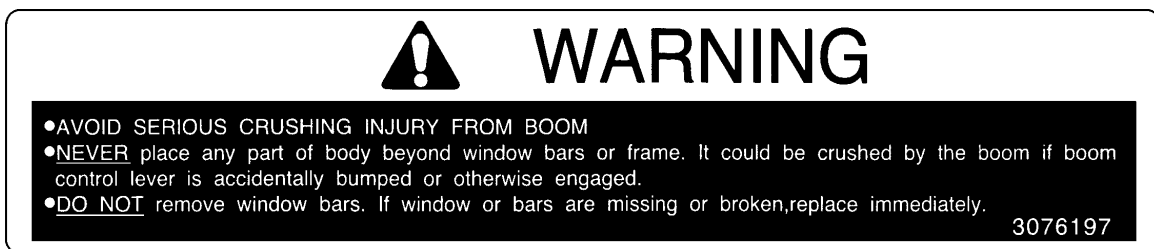

SS-859

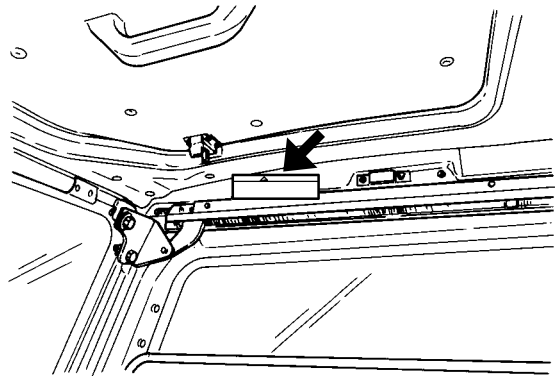

SS-1653

OPERATOR'S STATION

AUTO-IDLE SWITCH

While auto-idle switch (1) is turned on, engine speed decreases to the auto-idle setting from the engine control dial setting approximately 4 seconds after the control levers are returned to neutral. Indicator (2) stays on while auto-idle switch (1) is turned on.

Push auto-idle switch (1) again to turn off the auto-idle function. Indicator (2) will also be turned off.

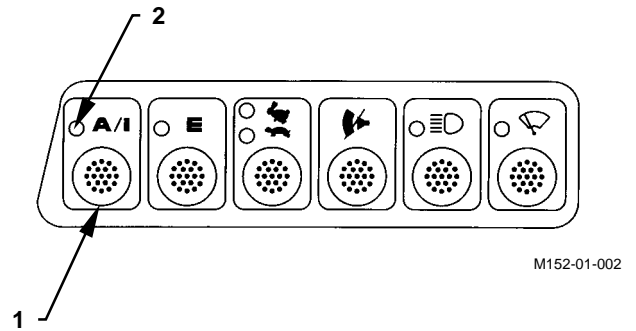

E (ECONOMY) MODE SWITCH

When E mode switch (3) is pushed, E mode indicator (4) on the monitor panel will light.

Although performance will decrease, fuel consumption and noise level will also decrease.

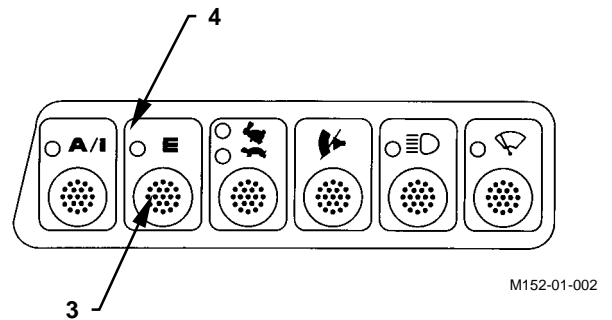

TRAVEL MODE SWITCH

Fast speed mode (rabbit) and slow speed mode (turtle) can be selected by pushing travel mode switch (5).

6-  Mark (Fast Speed Mode)

7-  Mark (Slow Speed Mode)

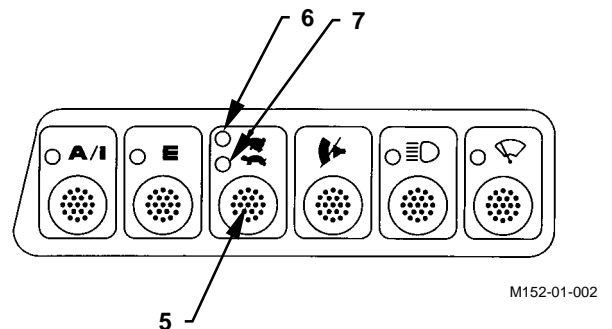

OPERATOR'S STATION

CAB HEATER OPERATION

When any mode switches (5) are pressed, warm air will blow out. However the foot vent mode  is commonly used for cab heater operation.

Press foot vent mode  switch (5). Turn on all the red indicators using temperature control switch (6).



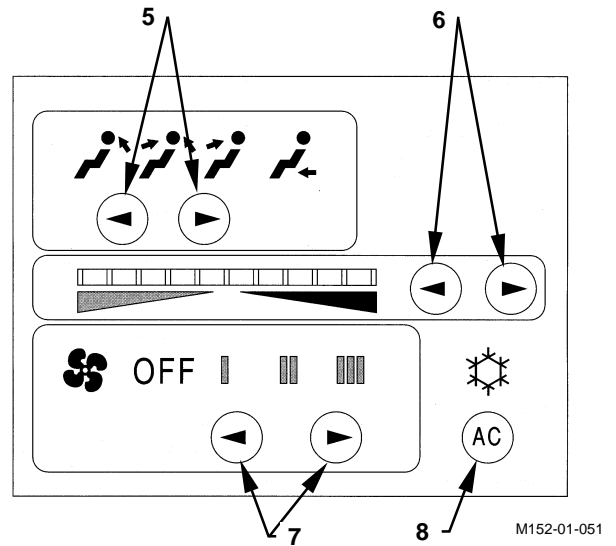

If blower switch (7) is pressed, warm air will blow out from foot vent.

Use temperature control switch (6) and blower switch (7) to adjust air temperature in the cab.

In addition, if air conditioner switch (8) is turned on while using the cab heater, the cab will be defogged.



COOLING OPERATION

When any mode switches (5) are pressed, cool air will blow out. However, the front vent mode  or front/rear vent mode  is commonly used for cooling operation. Press front vent mode  or front/rear vent mode  switch (5). Turn on all the blue indicators using temperature control switch (6).

If blower switch (7) is pressed, cool air will blow out from front vent and/or front/rear vent.

Use temperature control switch (6) and blower switch (7) to adjust air temperature in the cab.

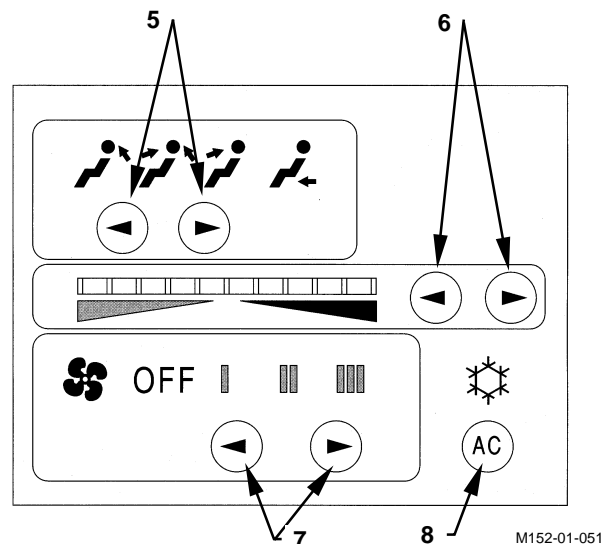



OPERATOR'S STATION

EMERGENCY EXIT

If the operator's cab door should not open in an emergency, escape in the following methods:

1. Open the front windows. Escape through the windows.

 **NOTE:** See page 1-32 "OPENING UPPER FRONT WINDOWS" for the opening method of the front windows.

 **CAUTION:** Be sure to wear safety glasses before breaking the window glass.

2. If the front window is difficult to open, break the front window glass using the emergency evacuation tool (1). Then, escape through the broken window.
3. If the front window is not available for escaping, break the rear window glass using the emergency evacuation tool. Then, escape through the broken window.

 **NOTE:** The emergency exit decals are affixed to the front and rear windows.

4. If neither of front and rear windows are available for emergency exit, open the overhead window to escape from the cab.

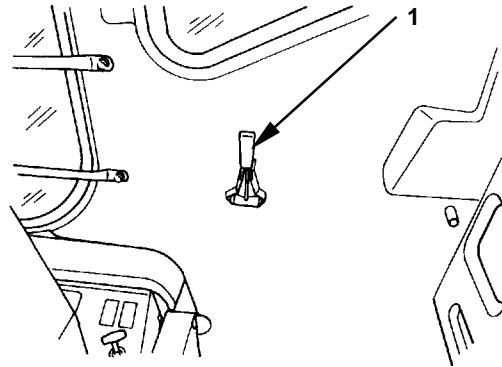

M161-01-023

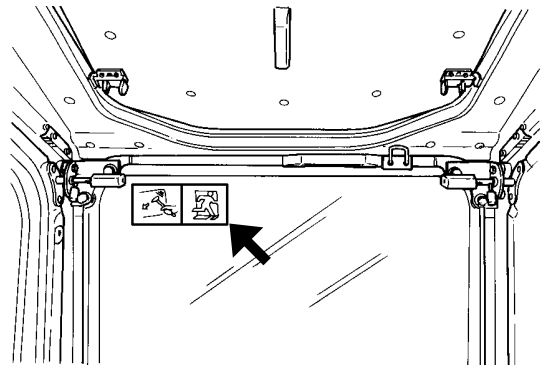

M157-01-163

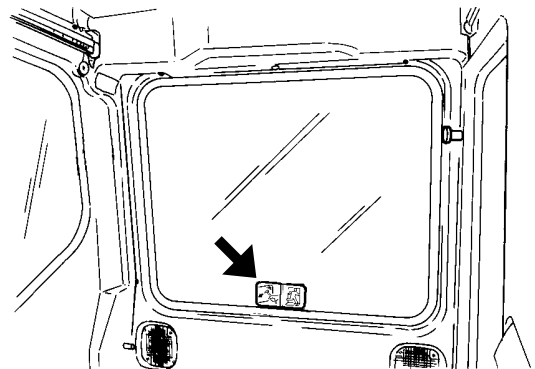

M161-01-024

DRIVING THE MACHINE

PRECAUTIONS FOR TRAVELING ON SLOPES



CAUTION: Avoid possible injury from traveling on slopes. Tipping over or skidding down of the machine may result. Thoroughly read and understand precautions below and be sure to travel at slow speed on slopes. Never attempt to travel on slopes with the bucket loaded or any load suspended by the bucket.

1. Never attempt to ascend or descend 30 degrees or steeper slopes.
2. Be sure to fasten the seat belt.
3. Keep the bucket pointed in the direction of travel, approximately 200 to 300 mm (8 to 12 in) (A) above the ground. If the machine starts to skid or becomes unstable, lower the bucket immediately.
4. Driving across the face of a slope or steering on a slope may cause the machine to skid or turnover. If the direction must be changed, move the machine to level ground, then, change the direction to ensure safe operation.
5. Avoid swinging the upperstructure on slopes. Never attempt to swing the upperstructure downhill. The machine may tip over. If swinging uphill is unavoidable, carefully operate the upperstructure and boom at slow speed.
6. If the engine stalls on a slope, immediately lower the bucket to the ground. Return the control levers to neutral. Then, restart the engine.
7. Be sure to thoroughly warm up the machine before ascending steep slopes. If hydraulic oil has not warmed up sufficiently, sufficient performance may not be obtained.

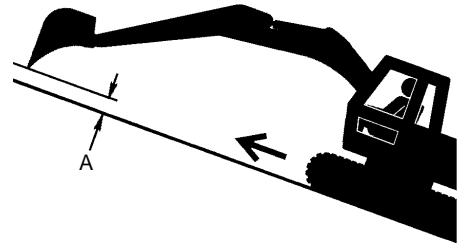

SA-657

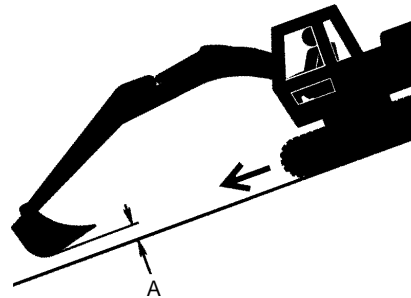

SA-658

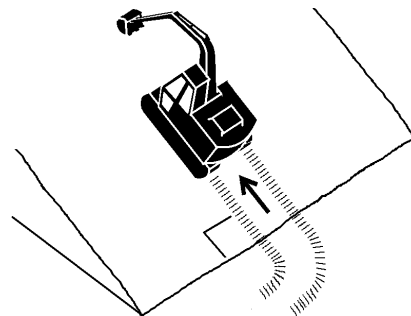

SA-441

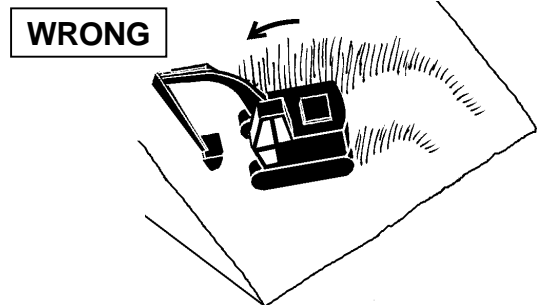

SA-442

OPERATING THE MACHINE

E (ECONOMY) MODE

Use the E mode when the priority is given to fuel consumption performance rather than work performance.

Although the engine speed decreases, the digging power is the same as that of the standard mode*. The work performance will decrease somewhat, but fuel consumption will also decrease, improving fuel efficiency and decreasing noise level. The E mode becomes effective when the general purpose mode is selected as the work mode.

 **NOTE:** *Standard Mode:*
H/P Mode Switch OFF
E Mode Switch OFF

When E mode switch (1) is pushed down, the switch will stay down. At the same time, E mode indicator (2) will light. Pushing the E mode switch again, the switch will pop up to the original position, deactivating the E mode.

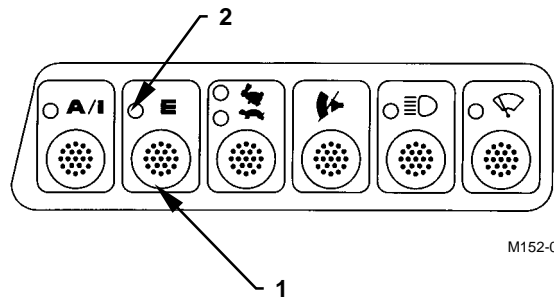

TRANSPORTING

Loading/Unloading



CAUTION:

1. Always turn the auto-idle switch OFF and the H/P mode switch OFF when loading or unloading the machine, to avoid unexpected speed increase due to unintentional operation of a control lever.
2. Always select the slow speed mode with the travel mode switch. In the fast speed mode, travel speed may automatically increase.
3. NEVER steer while driving up or down a ramp as it is extremely dangerous. If repositioning is necessary, first move back to the ground or flatbed, modify traveling direction, and begin to drive again.
4. The top end of the ramp where it meets the flatbed is a sudden bump. Take care when traveling over it.
5. Prevent possible injury from machine tipping while the upperstructure is rotating. Keep the arm tucked under and rotate the upperstructure slowly for best stability.

Loading

1. The machine direction should be as follows:
With the front attachment: Travel forward with the front attachment at the front.
Without the front attachment: Travel in reverse, as illustrated.
2. The centerline of the machine should be over the centerline of the trailer.
3. Drive the machine onto the ramp slowly.
With the front attachment:
 - Position the bucket with its flat surface resting on the trailer. Angle of the arm to boom should be 90 to 110°.
 - Rest the bucket on the trailer just before the machine begins to tip forward onto the trailer. Slowly travel forward until the tracks are firmly on the trailer.
 - Slightly raise the bucket. Keeping the arm tucked under, slowly rotate the upperstructure 180°.
 - Lower the bucket onto blocks.

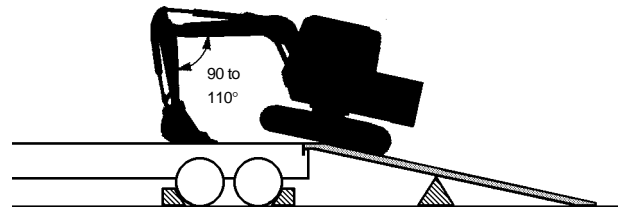

M102-06-001

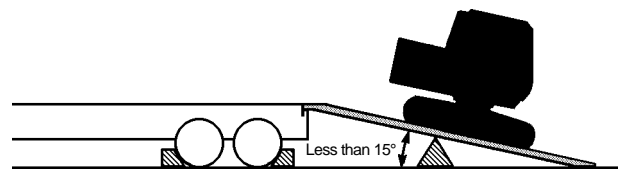

M102-06-002

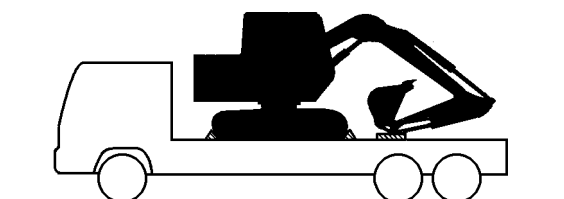

M102-06-005

CLICK HERE TO **DOWNLOAD** THE COMPLETE MANUAL

- Thank you very much for reading the preview of the manual.
- You can download the complete manual from: www.heydownloads.com by clicking the link below



- Please note: If there is no response to CLICKING the link, please download this PDF first and then click on it.

CLICK HERE TO **DOWNLOAD** THE COMPLETE MANUAL

MAINTENANCE

MAINTENANCE GUIDE

A. GREASING (See Page 7-9)

Parts		Quantity	Interval (hours)						
			8	50	100	250	500	1000	2000
1. Front Joint Pins	Bucket and Link Pins	8	★ ★★						
	Others	10	★ ★★						
2. Swing Bearing		2							
3. Swing Internal Gear		1							

 **NOTE:** Grease Bucket and Link Pins every 8 hours for the first 50 hours.
 ★ Grease every 8 hours for first 100 hours.
 ★★ Maintenance required when operating in water or mud.

B. ENGINE (See Page 7-14)

Parts		Quantity	Interval (hours)						
			8	50	100	250	500	1000	2000
1. Engine Oil	Oil Level Check	1							
2. Engine Oil	Change	12.5 L (3.3 US gal)							
3. Engine Oil Filter	Replacement	1							

C. TRANSMISSION (See Page 7-18)

Parts		Quantity	Interval (hours)						
			8	50	100	250	500	1000	2000
1. Swing Reduction Gear	Oil Level Check	1							
	Change	1.8 L (1.8 US qt)							
2. Travel Reduction Gear	Oil Level Check	2							
	Change	2.5 L × 2 (2.6 US qt) × 2							

MAINTENANCE



CAUTION: Engine oil may be hot. Take extra care to avoid burns.

8. Remove drain plug (3). Allow oil to drain through a clean cloth into a 50 liter (13 US gal) container.
9. After all oil has drained, inspect cloth for any debris such as small pieces of metal.
10. Install and tighten drain plug (3).
11. Remove the filter cartridges of engine oil filter (4) by turning it counterclockwise with the filter wrench.
12. Clean the filter gasket contact area on the engine.
13. Apply a thin film of clean oil to the gasket of the new filter.
14. Install new filter. Turn the filter cartridge clockwise by hand until the gasket touches the contact area. Be sure not to damage the gasket when installing the filter.
15. Tighten engine oil filter (4) 1/6 turn more using the filter wrench.
16. Remove the oil filler cap. Fill the engine with recommended oil. Check that oil level is between the circle marks on the dipstick after 15 minutes.
Engine oil capacity is 12.5 liters (3.3 US gal)
17. Install the oil filler cap.
18. Start the engine. Run the engine at slow idle for 5 minutes.
19. Check that the engine oil pressure indicator on the monitor panel goes out immediately. If not, stop the engine immediately and find the cause.
20. Stop the engine. Remove the key from the key switch.
21. Check for any leakage at the drain plug.
22. Check oil level on the dipstick.

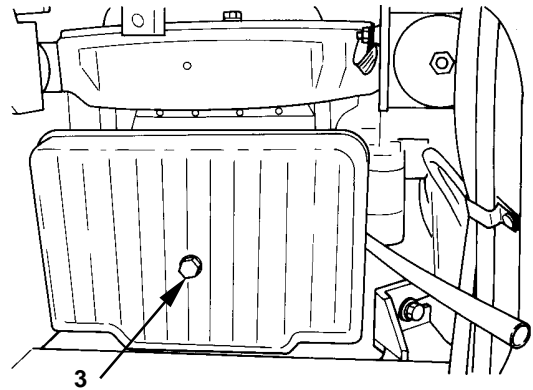

M152-07-029

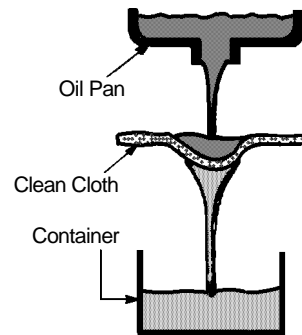

M104-07-010

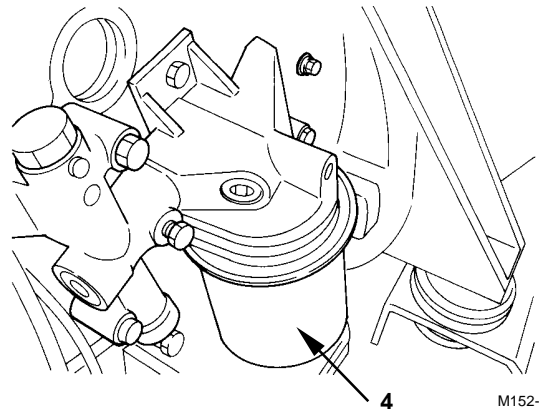

M152-07-037

MAINTENANCE

2

Drain Hydraulic Tank Sump --- every 250 hours

IMPORTANT: Never run the engine without oil in hydraulic oil tank.

1. Park the machine on a level surface with the upper-structure rotated 90° for easier access.
2. Lower the bucket to the ground.
3. Turn the auto-idle switch off.
4. Run the engine at slow idle speed without load for five minutes.
5. Turn the key switch OFF. Remove the key from the key switch.
6. Pull the pilot control shut-off lever to the LOCK position.



CAUTION: The hydraulic oil tank is pressurized. Push the pressure release button on the air breather to release pressure.

7. Push the pressure release button on the air breather to release pressure.



CAUTION: Do not loosen the drain plug until oil is cool. Hydraulic oil may be hot, potentially causing serious injury.

8. After oil is cool, loosen drain plug (1) to drain water and sediment. Do not remove the plug completely, only loosen it enough to drain water and sediment.
9. After draining water and sediment, retighten the plug.

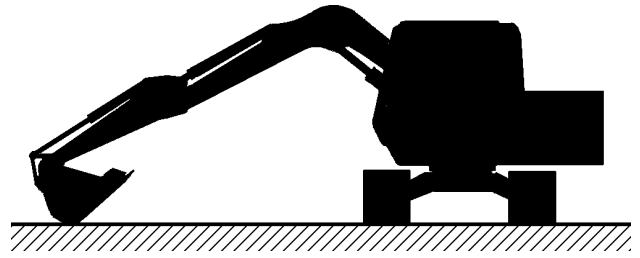

M102-07-076

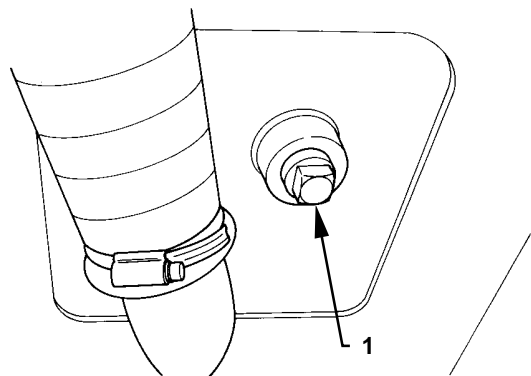

M152-07-017

MAINTENANCE

E. FUEL SYSTEM

Tank capacity 250 liter (66 US gal)

Parts	Quantity	Interval (hours)						
		8	50	100	250	500	1000	2000
1. Drain Fuel Tank Sump	1							
2. Replace Fuel Filter	1							
3. Clean Feed Pump Strainer	1							
4. Check Fuel Hoses	for leaks, cracks, etc.							
	for cracks, bend, etc.							

Recommended Fuel

Use high quality DIESEL FUEL only (JIS K-2204) (ASTM 2-D). Kerosene must NOT be used.

Refueling

1. Park the machine on a level surface.
2. Lower the bucket to the ground.
3. Turn the auto-idle switch off.
4. Run the engine at slow idle speed without load for five minutes.
5. Stop the engine. Remove the key from the key switch.
6. Pull the pilot control shut-off lever to the LOCK position.
7. Check fuel level gauge (3) or fuel gauge (1) of the monitor panel. Add fuel if necessary.

CAUTION: Handle fuel carefully. Shut the engine off before fueling. Do not smoke while you fill the fuel tank or work on fuel system.

IMPORTANT: Keep all dirt, dust, water and other foreign materials out of the fuel system.

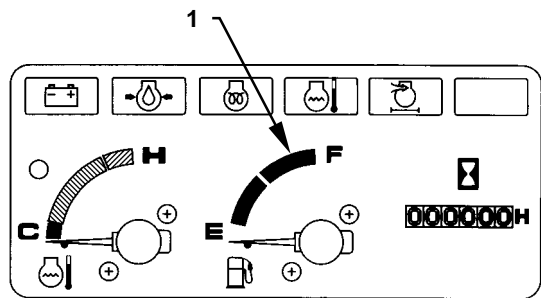

M152-01-016

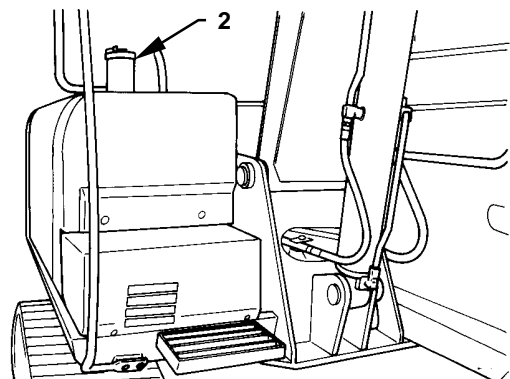

M152-07-022

MAINTENANCE

Antifreeze Mixing Table

Air temperature		Mixing ratio	Refill capacities			
			Antifreezes		Soft water	
°C	°F	%	liters	US gal	liters	US gal
-1	30	30	3.0	0.79	7.0	1.85
-4	25	30	3.0	0.79	7.0	1.85
-7	19	30	3.0	0.79	7.0	1.85
-11	12	30	3.0	0.79	7.0	1.85
-15	5	35	3.5	0.93	6.5	1.72
-20	-4	40	4.0	1.06	6.0	1.59
-25	-13	45	4.5	1.19	5.5	1.45
-30	-22	50	5.0	1.32	5.0	1.32



CAUTION:

1. Antifreeze is poisonous; if ingested, it can cause serious injury or death. Induce vomiting and get emergency medical attention immediately.
2. When storing antifreeze, be sure to keep it in a clearly marked container with a tight lid. Always keep antifreeze out of the reach of children.
3. If antifreeze is accidentally splashed into eyes, flush with water for 10 to 15 minutes and get emergency medical attention.
4. When storing or disposing of antifreeze, be sure to comply with all local regulations.

MAINTENANCE

- Clean shank (6) surface.
- Install rubber pin lock (4) into shank (6) hole as shown.

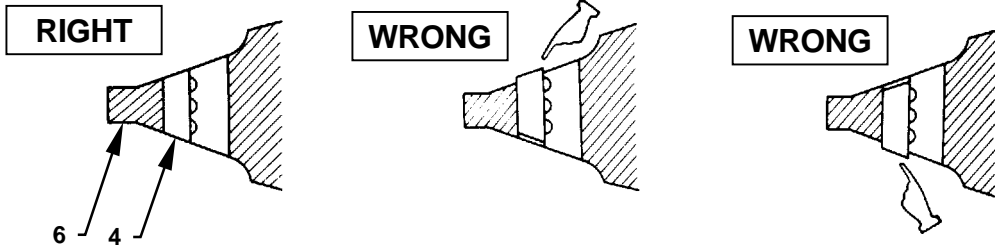

M104-07-060

- Position new tooth (1) over shank (6).

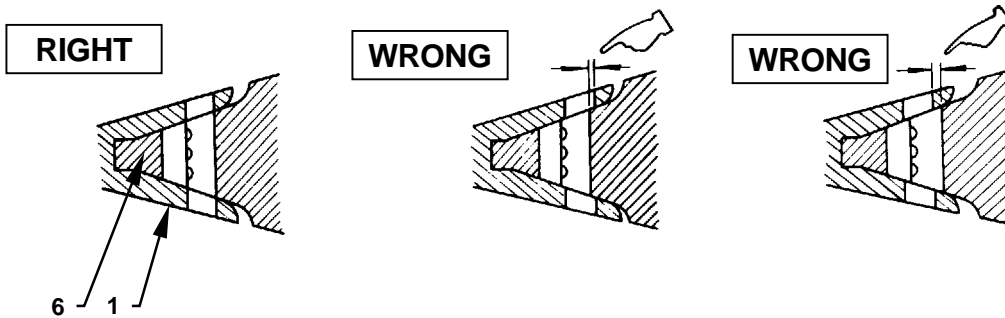

M104-07-061

- Drive locking pin (5) fully into the hole as shown.

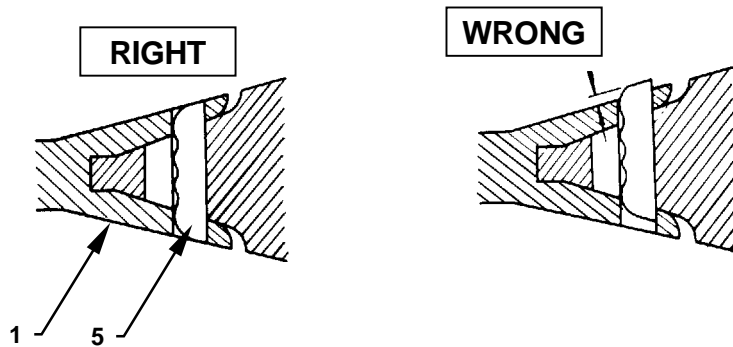

M104-07-062

 **NOTE:** Check the bucket teeth periodically to ensure that wear does not exceed the designed service limit.

MAINTENANCE

CONVERTING THE CRAWLER



CAUTION: When converting the crawler from steel to rubber or rubber to steel, readjustment of the track adjuster is required. Be sure to consult your authorized dealer for the adjusting operations. Never attempt to disassemble the track adjuster, as high-pressure grease inside the adjuster can cause serious injury if released.

Be sure to consult your authorized dealer when converting the crawler from steel to rubber or rubber to steel.

TROUBLESHOOTING

ELECTRICAL SYSTEM

Problem	Cause	Solution
Engine Cranks Slowly	Battery discharged or will not hold a charge Starter "dragging" Low battery voltage	Replace battery. See your authorized dealer. Recharge or replace battery.
Starter Motor Continues to Run After Engine Starts	Start relay stuck Starter solenoid stuck Starter not disengaging Key switch	See your authorized dealer. See your authorized dealer. See your authorized dealer. See your authorized dealer.
Charging Indicator Light On-Engine Running	Loose or glazed alternator belt Engine rpm low Excessive electrical load from added accessories Loose or corroded electrical connections on battery, ground strap, starter, or alternator Battery voltage low Alternator or regulator Indicator circuit	Check belt. Replace if glazed, tighten if loose. Adjust rpm to specification. Remove accessories or install higher output alternator. Inspect, clean, or tighten electrical connections. Change or replace battery. See your authorized dealer. See your authorized dealer.
Noisy Alternator	Worn drive belt Worn pulleys Pulley misaligned Alternator bearing	Replace belt. Replace pulleys and belt. Adjust alternator mount. Loosen alternator belts. Turn pulley by hand. If any roughness is felt, repair alternator.
No Monitor Panel Indicators Work	Fuse Wiring harness	Replace fuse. See your authorized dealer.
Individual Light in Monitor Panel is Not Working	Bulb Fuse Wiring harness	Replace bulb. Replace fuse. See your authorized dealer.

SPECIFICATIONS

SHOE TYPES AND APPLICATIONS

EX60-5 [For 1.62m (5' 4") arm with PCSA 0.28m³ (0.37 cuyd) standard bucket]

Shoe Width		450 (18") Grouser Shoe	600 (24") Grouser Shoe	450 (18") Flat Shoe	500 (20") Triangular Shoe	700 (28") Triangular Shoe	450 (18") Rubber-covere d Shoe	450 (18") Rubber Crawler
Application		For Ordinary Ground (Standard)	For Weak Footing (Option)	For Paved Road (Option)	For Weak Footing (Option)	For Weak Footing (Option)	For Paved Road (Option)	For Paved Road (Option)
Operating Weight	kg (lb)	6300 (13900)	6460 (14200)	6460 (14240)	6480 (14290)	6600 (14600)	6450 (14220)	6300 (13900)
Basic Machine Weight	kg (lb)	5050 (11100)	5210 (11500)	5210 (11500)	5230 (11500)	5350 (11800)	5200 (11500)	5050 (11100)
Cab Height	mm (ft·in)	2570 (8' 5")	2570 (8' 5")	2580 (8' 6")	2610 (8' 7")	2610 (8' 7")	2585 (8' 6")	2570 (8' 5")
Minimum Ground Clearance	mm (ft·in)	*360 (14")	*360 (14")	390 (15")	*360 (14")	*360 (14")	395 (15")	380 (15")
Undercarriage Length	mm (ft·in)	2765 (9' 1")	2765 (9' 1")	2785 (9' 2")	2845 (9' 4")	2845 (9' 4")	2795 (9' 2")	2785 (9' 2")
Undercarriage Width	mm (ft·in)	2200 (7' 3")	2350 (7' 9")	2200 (7' 3")	2250 (7' 3")	2450 (8' 0")	2200 (7' 3")	2200 (7' 3")
Ground Pressure	kPa (kgf/cm ²) (PSI)	29.1 (0.30) (4.2)	22.4 (0.23) (3.2)	29.9 (0.30) (4.3)	27.0 (0.27) (3.9)	19.6 (0.20) (2.8)	29.8 (0.30) (4.2)	29.1 (0.30) (4.2)

EX60LC-5 [For 1.62m (5' 4") arm with PCSA 0.34m³ (0.44 cuyd) standard bucket]

Shoe Width		450 (18") Grouser Shoe	600 (24") Grouser Shoe	450 (18") Flat Shoe	500 (20") Triangular Shoe	700 (28") Triangular Shoe	450 (18") Rubber-covere d Shoe	450 (18") Rubber Crawler
Application		For Ordinary Ground (Standard)	For Weak Footing (Option)	For Paved Road (Option)	For Weak Footing (Option)	For Weak Footing (Option)	For Paved Road (Option)	For Paved Road (Option)
Operating Weight	kg (lb)	6390 (14100)	6560 (14500)	6560 (14500)	6580 (14500)	6710 (14800)	6550 (14400)	6390 (14100)
Basic Machine Weight	kg (lb)	5140 (11300)	5310 (11700)	5310 (11700)	5330 (11800)	5460 (12000)	5300 (11700)	5140 (11300)
Cab Height	mm (ft·in)	2570 (8' 5")	2570 (8' 5")	2580 (8' 6")	2610 (8' 7")	2610 (8' 7")	2585 (8' 6")	2570 (8' 5")
Minimum Ground Clearance	mm (ft·in)	*360 (14")	*360 (14")	390 (15")	*360 (14")	*360 (14")	395 (15")	380 (15")
Undercarriage Length	mm (ft·in)	2920 (9' 7")	2920 (9' 7")	2940 (9' 8")	3000 (9' 8")	3000 (9' 8")	2950 (9' 8")	2940 (9' 8")
Undercarriage Width	mm (ft·in)	2300 (7' 7")	2450 (8' 0")	2300 (7' 7")	2350 (7' 9")	2550 (8' 4")	2300 (7' 7")	2300 (7' 7")
Ground Pressure	kPa (kgf/cm ²) (PSI)	27.8 (0.28) (4.0)	21.4 (0.22) (3.1)	28.5 (0.29) (4.1)	25.7 (0.26) (3.7)	18.7 (0.19) (2.7)	28.5 (0.29) (4.1)	27.8 (0.28) (4.0)

 **NOTE:** • The rubber crawler is designed for use on paved surfaces. Do not use the rubber crawler on gravel or rocky ground.

• Only the 450 mm (18") grouser shoe can be used on rough terrain (gravel or rocky ground). If the other shoes are used for general engineering works and works on rivers and rough grounds, they will twist the shoes and loosen the shoe bolts, causing damages to other undercarriage parts (links, rollers, track frame, etc).

• * The dimensions do not include the height of the shoe lug.

OPTIONAL ATTACHMENTS AND DEVICES

PRECAUTIONS FOR CRUSHER OPERATION

Prevent machine tipping over and damage to the front attachment. Observe the following precautions for crusher operation.



CAUTION: Machine stability is reduced as crusher is much heavier than bucket. When operating with a crusher, the machine is more apt to tip over. Also, falling or flying objects may hit the cab or other part of the machine. Observe the following precautions and take any other precautions necessary to prevent accidents and machine damage from occurring.

- Do not allow the machine's weight to be supported by the crusher or bucket cylinder with the bucket cylinder fully extended or retracted. Doing so may damage the front attachment. In particular, avoid doing so with the bucket cylinder fully extended, as the front attachment will be easily damaged. Take care to prevent this from happening when dismantling foundation structures using the crusher.

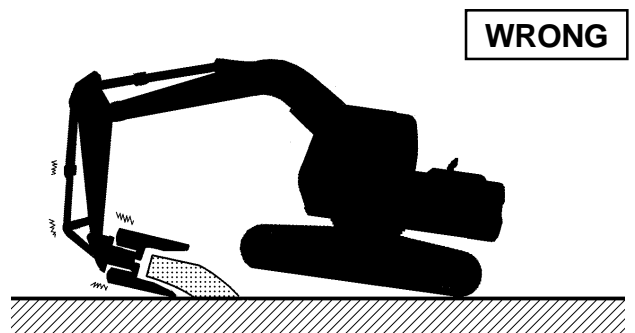

- Do not attempt to perform crushing on either side of the machine. Always perform crushing operations to the fore or rear, parallel with the tracks. Otherwise, tipping over may occur.

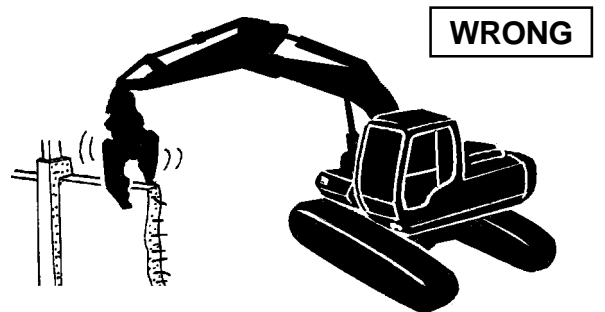

OPTIONAL ATTACHMENTS AND DEVICES

Shoe Types and Applications

EX60-5 [For 1.62m (5' 4") arm with PCSA 0.28m³ (0.37 cuyd) standard bucket with blade]

Shoe Width	450 (18") Grouser Shoe	600 (24") Grouser Shoe	450 (18") Flat Shoe	500 (20") Triangular Shoe	700 (28") Triangular Shoe	450 (18") Rubber-covere d Shoe	450 (18") Rubber Crawler	
Application	For Ordinary Ground (Standard)	For Weak Footing (Option)	For Paved Road (Option)	For Weak Footing (Option)	For Weak Footing (Option)	For Paved Road (Option)	For Paved Road (Option)	
Operating Weight	kg (lb)	6830 (15100)	6990 (15400)	6990 (15400)	7010 (15500)	7130 (15700)	6980 (15400)	6830 (15100)
Basic Machine Weight	kg (lb)	5580 (12300)	5740 (12700)	5740 (12700)	5760 (12700)	5880 (13000)	5730 (12600)	5580 (12300)
Cab Height	mm (ft·in)	2570 (8' 5")	2570 (8' 5")	2580 (8' 6")	2610 (8' 7")	2610 (8' 7")	2585 (8' 6")	2570 (8' 5")
Minimum Ground Clearance	mm (ft·in)	★360 (14")	★360 (14")	390 (15")	★360 (14")	★360 (14")	395 (15")	380 (15")
Undercarriage Length	mm (ft·in)	2765 (9' 1")	2765 (9' 1")	2785 (9' 2")	2845 (9' 4")	2845 (9' 4")	2795 (9' 2")	2785 (9' 2")
Undercarriage Width	mm (ft·in)	2200 (7' 3")	2350 (7' 9")	2200 (7' 3")	2250 (7' 3")	2450 (8' 0")	2200 (7' 3")	2200 (7' 3")
Ground Pressure	kPa (kgf/cm ²) (PSI)	31.6 (0.32) (4.6)	24.2 (0.25) (3.5)	32.3 (0.33) (4.7)	29.2 (0.30) (4.2)	21.2 (0.22) (3.1)	32.3 (0.33) (4.7)	31.6 (0.32) (4.6)

EX60LC-5 [For 1.62m (5' 4") arm with PCSA 0.34m³ (0.44 cuyd) standard bucket]

Shoe Width	450 (18") Grouser Shoe	600 (24") Grouser Shoe	450 (18") Flat Shoe	500 (20") Triangular Shoe	700 (28") Triangular Shoe	450 (18") Rubber-covere d Shoe	450 (18") Rubber Crawler	
Application	For Ordinary Ground (Standard)	For Weak Footing (Option)	For Paved Road (Option)	For Weak Footing (Option)	For Weak Footing (Option)	For Paved Road (Option)	For Paved Road (Option)	
Operating Weight	kg (lb)	6920 (15300)	7090 (15600)	7090 (15600)	7110 (15700)	7240 (16000)	7080 (15600)	6920 (15300)
Basic Machine Weight	kg (lb)	5670 (12500)	5840 (12900)	5840 (12900)	5860 (12900)	5990 (13200)	5830 (12800)	5670 (12500)
Cab Height	mm (ft·in)	2570 (8' 5")	2570 (8' 5")	2580 (8' 6")	2610 (8' 7")	2610 (8' 7")	2585 (8' 6")	2570 (8' 5")
Minimum Ground Clearance	mm (ft·in)	★360 (14")	★360 (14")	390 (15")	★360 (14")	★360 (14")	395 (15")	380 (15")
Undercarriage Length	mm (ft·in)	2920 (9' 7")	2920 (9' 7")	2940 (9' 8")	3000 (9' 8")	3000 (9' 8")	2950 (9' 8")	2940 (9' 8")
Undercarriage Width	mm (ft·in)	2300 (7' 7")	2450 (8' 0")	2300 (7' 7")	2350 (7' 9")	2550 (8' 4")	2300 (7' 7")	2300 (7' 7")
Ground Pressure	kPa (kgf/cm ²) (PSI)	30.1 (0.31) (4.4)	23.1 (0.24) (3.4)	30.8 (0.31) (4.5)	27.8 (0.28) (4.0)	20.2 (0.21) (2.9)	30.8 (0.31) (4.5)	30.1 (0.31) (4.4)

 **NOTE:** • The rubber crawler is designed for use on paved surfaces. Do not use the rubber crawler on gravel or rocky ground.

• Only the 450 mm (18") grouser shoe can be used on rough terrain (gravel or rocky ground). If the other shoes are used for general engineering works and works on rivers and rough grounds, they will twist the shoes and loosen the shoe bolts, causing damages to other undercarriage parts (links, rollers, track frame, etc).

• ★ The dimensions do not include the height of the shoe lug.

OPTIONAL ATTACHMENTS AND DEVICES

Working Ranges (off-set)

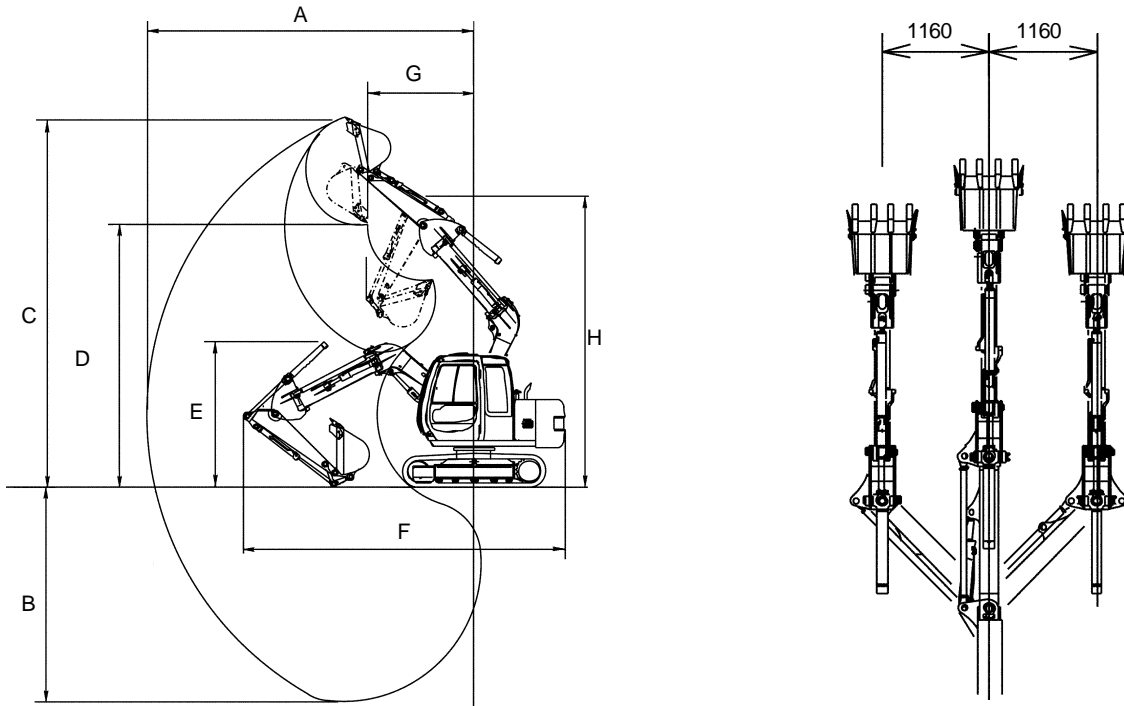

M152-14-006

M152-14-005

Item	Category	Working Ranges			
		Off-set Distance	(0 mm) (0")	Max. Off-set Distance	(1160 mm) (3' 10")
A : Maximum Digging Reach	mm (ft·in)	6310 (20' 8")		5860 (19' 3")	
B : Maximum Digging Depth	mm (ft·in)	4150 (13' 7")		3690 (12' 1")	
C : Maximum Cutting Height	mm (ft·in)	7120 (23' 4")		6760 (22' 2")	
D : Maximum Dumping Height	mm (ft·in)	5070 (16' 8")		4710 (15' 5")	
* ¹ E : Transport Height	mm (ft·in)	2810 (9' 3")		2780 (9' 1")	
F : Overall Transport Length	mm (ft·in)	6200 (20' 4")		5780 (19' 0")	
G : Minimum Swing Radius	mm (ft·in)	2080 (6' 10")		left 2140 (7' 0") right 2220 (7' 3")	
H : Front-end Attachment Height at Min. Swing Radius	mm (ft·in)	5620 (18' 5")		5260 (17' 3")	

NOTE: *¹ The dimensions include the height of the shoe lug.

CLICK HERE TO **DOWNLOAD** THE COMPLETE MANUAL

- Thank you very much for reading the preview of the manual.
- You can download the complete manual from: www.heydownloads.com by clicking the link below



- Please note: If there is no response to CLICKING the link, please download this PDF first and then click on it.

CLICK HERE TO **DOWNLOAD** THE COMPLETE MANUAL