

Grove RT600E

Operator Manual



Grove

Manitowoc

National Crane

Potain



CLICK HERE TO **DOWNLOAD** THE COMPLETE MANUAL

- Thank you very much for reading the preview of the manual.
- You can download the complete manual from: www.heydownloads.com by clicking the link below



- Please note: If there is no response to CLICKING the link, please download this PDF first and then click on it.

CLICK HERE TO **DOWNLOAD** THE COMPLETE MANUAL

SERIAL NUMBER LOCATION FIGURE 1-2



FIGURE 1-1

Item	Description
1	Swingaway
2	Auxiliary Boom Nose
3	Swingaway Extension
4	Boom
5	Boom Nose Sheaves
6	LMI Cable Reel
7	Spotlight
8	Work Light
9	Hydraulic Tank
10	Main Hoist
11	Auxiliary Hoist
12	Counterweight
13	Muffler
14	Air Intake Cleaner
15	Windshield Washer Fluid Container

Item	Description
16	Beacon Light
17	Cab
18	Boom Pivot
19	Front Axle
20	Fuel Tank
21	Driveline
22	Hookblock Tie Down
23	Battery
24	Transmission
25	Rear Axle
26	Oil Cooler
27	Lift Cylinder
28	Outrigger Float
29	Outrigger Jack Cylinder
30	Steps

Table 2-1

Wind Force		Wind Velocity km/h (mph)	Visible Indicator Effects of wind as observed on land
Beauford Scale	Designation		
Zero (0)	Calm	less than 2 (<1)	No wind; smoke rises vertically
1	Light Air	2-5 (1-3)	Wind direction seen by smoke but not by wind vanes
2	Light Breeze	6-11 (4-7)	Wind felt on face; leaves rustle; wind vane moves slightly
3	Gentle Breeze	13-19 (8-12)	Leaves/small twigs in constant motion; wind extends flag
4	Moderate Breeze	21-29 (13-18)	Raises dust & loose paper; moves small branches
Reduce crane load ratings and operating parameters at 32 km/h (20 mph)			
5	Fresh Breeze	31-39 (19-24)	Small trees in leaf begin to sway; on ponds, crested wavelets form
6	Strong Breeze	40-50 (25-31)	Large branches in motion; telegraph wires whistle; umbrellas used with difficulty
Cease all craning operations at 48 km/h (30 mph); lower & retract boom			
7	Moderate Gale	52-61 (32-38)	Whole trees in motion; walking against wind is inconvenient

Lifting Operations

Before lifting, position the crane on a firm surface, properly extend and set the outriggers, and level the crane. Depending on the nature of the supporting surface, adequate cribbing may be required to obtain a larger bearing surface.

The crane is equipped with a bubble level that should be used to determine whether the crane is level. The load line can also be used to estimate the levelness of the crane by checking to be sure it is in-line with the center of the boom at all points on the swing circle.

If the boom extension, or auxiliary boom nose is to be used, ensure the electrical cable and the weight for the Anti-Two-Block Switch are properly installed and the LMI is programmed for the crane configuration. Refer to the LMI handbook supplied with the crane.

Verify the crane's capacity by checking the *Load Chart* against the weight of the load. Then, lift the load slightly at first to ensure stability before proceeding with the lift.

Be sure the load is properly rigged and attached. Always determine the weight of the load before you attempt to lift it and remember that all rigging (slings, etc.) and lifting devices (hook block, boom extension, etc.) must be considered part of the load.

Measure the load radius before making a lift and stay within approved lifting areas based on the range diagrams and working area diagrams on the crane's *Load Chart*.

Always keep the load as near to the crane and as close to the ground as possible.

Do not overload the crane by exceeding the capacities shown on the appropriate *Load Chart*. Death or serious injury could result from the crane tipping over or failing structurally from overload.

The crane can tip over or fail structurally if:

- The load and crane's configuration is not within the capacity as shown on the applicable *Load Chart* and notes.
- The ground is soft and/or the surface conditions are poor.
- Outriggers are not properly extended and set. On models equipped with outriggers that can be pinned at the mid-extend position, the outriggers must also be pinned when operating from the mid-extend position.
- Cribbing under the outrigger pads is inadequate.
- The crane is improperly operated.

Do not rely on the crane's tipping to determine your lifting capacity.

Be sure the hoist line is vertical before lifting. Do not subject the crane to side loading. A side load can tip the crane or cause it to fail structurally.

Load Chart capacities are based on freely suspended loads. Do not pull posts, pilings, or submerged articles. Be sure the load is not frozen or otherwise attached to the ground before lifting.

If you should encounter a tipping condition, immediately lower the load with the hoist line and retract or elevate the



“Stunt” driving and “horse-play” are strictly prohibited. Never allow anyone to hitch a ride or get on or off a moving crane.

Follow the instructions in this manual when preparing the crane for travel.

If using a boom dolly/trailer, thoroughly read and understand all the steps and safety precautions in this manual for setup and travel.

When driving the crane, ensure the cab is level, if equipped with a tilting cab.

Secure the hook block and other items before moving the crane.

Watch clearances when traveling. Do not take a chance of running into overhead or side obstructions.

When moving in tight quarters, post a signal person to help guard against collisions or bumping structures.

Before traveling a crane, check suitability of proposed route with regard to crane height, width, and length.

Never back up without the aid of a signal person to verify the area behind the crane is clear of obstructions and/or personnel.

On cranes equipped with air-operated brakes, do not attempt to move the crane until brake system air pressure is at operating level.

Check load limit of bridges. Before traveling across bridges, ensure they will carry a load greater than the crane's weight.

If it is necessary to take the crane on a road or highway, check state and local restrictions and regulations.

Keep lights on, use traffic warning flags and signs, and use front and rear flag vehicles when necessary. Check state and local restrictions and regulations.

Always drive the crane carefully obeying speed limits and highway regulations.

Stay alert at the wheel.

If equipped, ensure that the hoist access platform hand rail and step are in the travel configuration.

Slopes:

- Pick and carry on level surfaces only.
- Refer to the *Operation Section* for more detailed information on traveling on slopes.
- Driving across a slope is dangerous, as unexpected changes in slope can cause tip over. Ascend or descend slopes slowly and with caution.
- When operating on a downhill slope, reduce travel speed and downshift to a low gear to permit compression braking by the engine and aid the application of the service brakes.

WORK PRACTICES

Personal Considerations

Always adjust the seat and lock it in position, and fasten the seat belt securely before you start the engine.

Do not wear loose clothing or jewelry that can get caught on controls or moving parts. Wear the protective clothing and personal safety gear issued or called for by the job conditions. Hard hat, safety shoes, ear protectors, reflective clothing, safety goggles, and heavy gloves may be required.

Crane Access



Working at elevated heights without using proper fall protection can result in severe injury or death.

Always use proper fall protection as required by local, state or federal regulations.

You must take every precaution to ensure you do not slip and/or fall off the crane. Falling from any elevation could result in serious injury or death.

Never exit or enter the crane cab or deck by any other means than the access system(s) provided (i.e., steps and grab handles). Use the recommended hand-holds and steps to maintain a three-point contact when getting on or off the crane.

If necessary, use a ladder or aerial work platform to access the boom nose.

Do not make modifications or additions to the crane's access system that have not been evaluated and approved by Manitowoc Crane Care.

Do not step on surfaces on the crane that are not approved or suitable for walking and working. All walking and working surfaces on the crane should be clean, dry, slip-resistant, and have adequate supporting capacity. Do not walk on a surface if slip-resistant material is missing or excessively worn.

Do not use the top of the boom as a walkway.

Do not step on the outrigger beams or outrigger pads (floats) to enter or exit the crane.

Use the hoist access platform (if equipped) when working in the hoist area.

Wear shoes with a highly slip-resistant sole material. Clean any mud or debris from shoes before entering the crane cab/operator's station or climbing onto the crane superstructure. Excessive dirt and debris on the hand-holds, access steps,

Overload less than 25%			
1	Sheaves	Inspect all for damage.	
2	Luffing Mechanism/ Cylinder	Inspect for damage/leaks.	
3	Collar-wear pads	Inspect all for damage.	
Overload from 25% to 49%			
1	Sheaves	Inspect all for damage.	
2	Luffing Mechanism/ Cylinder	Inspect for damage/leaks.	
3	Collar-wear pads	Inspect all for damage.	
4	Collar-welds	Inspect all for cracks.	
5	Telescopic Sections	Inspect for bent or twisted sections. Check the boom for straightness.	
6	Lift Cylinder Head Area	Inspect for bends or cracked welds.	
7	Turret-Base Section	Inspect for cracked welds.	
8	Locking Area (Pin Booms)	Inspect for elongated holes.	
9	Welds	Inspect for cracks.	
10	Paint	Inspect for cracked paint which could indicate twisted, stretched, or compressed members.	



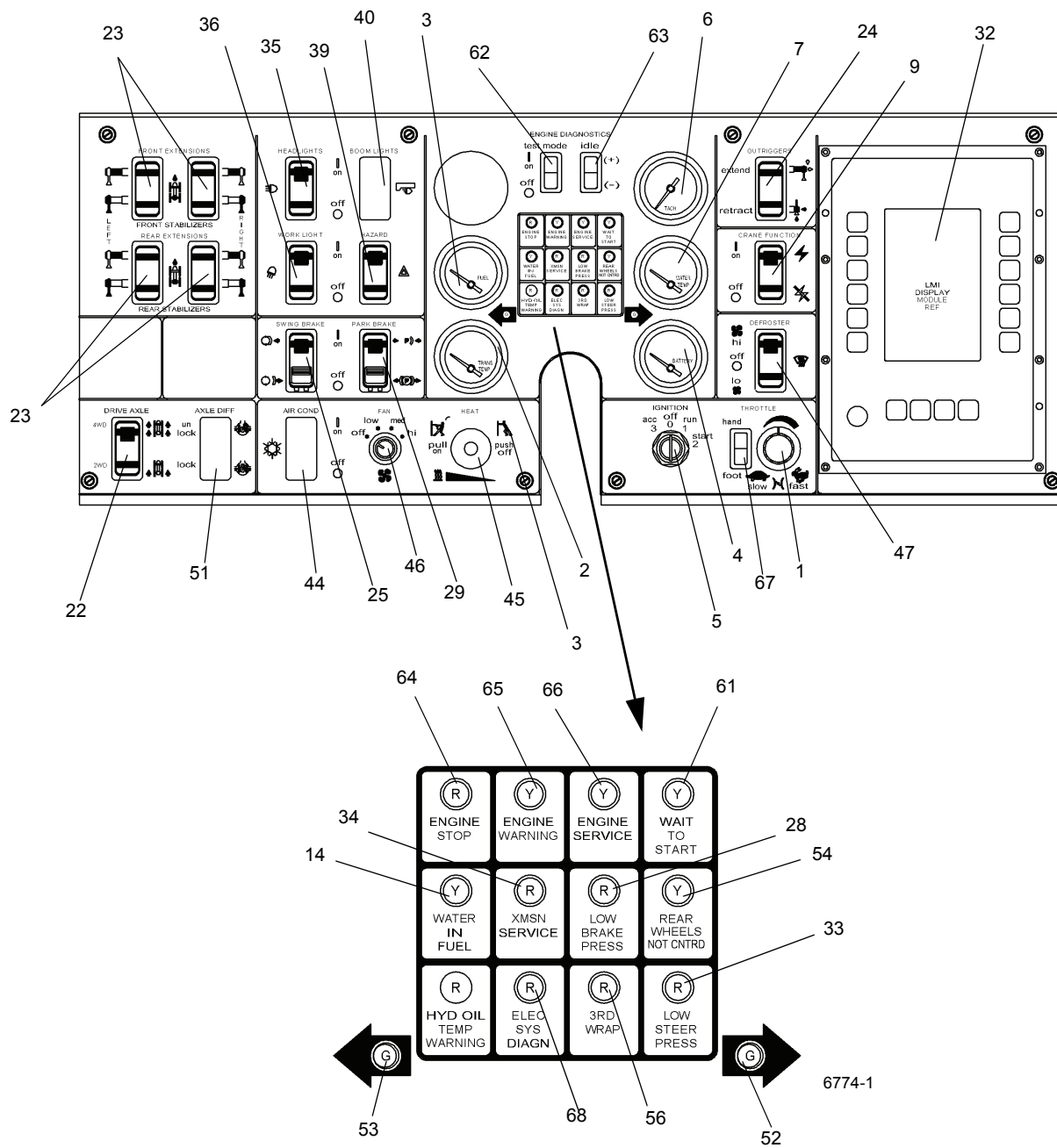

6774

6774-1

FIGURE 3-3

CLICK HERE TO **DOWNLOAD** THE COMPLETE MANUAL

- Thank you very much for reading the preview of the manual.
- You can download the complete manual from: www.heydownloads.com by clicking the link below



- Please note: If there is no response to CLICKING the link, please download this PDF first and then click on it.

CLICK HERE TO **DOWNLOAD** THE COMPLETE MANUAL

2. Turn the IGNITION switch to START (2) and release immediately when the engine starts. Do not push or hold the throttle down. The ECM will automatically provide the proper amount of fuel to start the engine.
3. The WAIT TO START lamp is illuminated during the preheat time that takes place when the IGNITION switch is in the ON position during cold weather starting. To minimize cranking time during cold weather starting, the engine should not be cranked until the WAIT TO START lamp turns off.
4. Immediately check the engine instruments for proper indication after starting. Shut down the engine if the oil pressure gauge does not reach the proper reading within 15 seconds.

CAUTION

If oil pressure and/or temperature indicator(s) do not display proper readings, shut down the engine and correct the malfunction before resuming operation.

5. Allow the engine to warm up for about five minutes before applying a load. Do not race the engine for a faster warm up.

Cold Engine



WARNING

Do not spray starting fluid into the air inlet. The spray will contact the heater elements and could explode causing personal injury.

NOTE: The engine ECM monitors the engine and, under certain conditions, cycles the air heater on and off at start-up and during operation.

The engine is equipped with an electric air heater grid at the air inlet elbow to aid in cold starting and reduce white smoke at start-up. In the preheat mode, the engine should not be cranked until the WAIT TO START lamp turns off.

1. Prior to starting a cold engine, ensure the CRANE FUNCTION switch is positioned to OFF and the hydraulic pump disconnected.
2. Ensure the parking brake is set and position the transmission in neutral.

NOTE: The engine will not crank unless the transmission is in neutral.

3. The WAIT TO START lamp is illuminated during the preheat time that takes place when the IGNITION switch is in the ON position during cold weather starting. To minimize cranking time during cold weather starting, the

engine should not be cranked until the WAIT-TO-START lamp turns off.

4. Turn the IGNITION switch to START and release immediately when the engine starts. Do not push or hold the throttle down. The ECM will automatically provide the proper amount of fuel to start the engine.
5. Immediately check the engine instruments for proper indication after starting. Shut down the engine if the oil pressure gauge does not reach the proper reading within 15 seconds.

CAUTION

If oil pressure and/or temperature indicator(s) do not display proper readings, shut down the engine and correct the malfunction before resuming operation.

6. Allow the engine to warm up for about five minutes before applying a load. Do not race the engine for a faster warm up.

Detailed cold weather starting and operating procedures are covered in the engine manual.

Cold Weather Starting

The engine is equipped with an electric air heater grid. An optional engine block heater is also provided.

Prior to starting a cold engine, ensure the CRANE FUNCTION switch is positioned to OFF and the hydraulic pump disconnected if the optional disconnect is provided.

To start the engine, turn the IGNITION switch to START (2). If the engine does not start within 30 seconds, allow the starter to cool a minute or two and repeat the procedure.

Detailed cold weather starting and operating procedures are covered in the engine manual.

Idling The Engine

Idling the engine unnecessarily for long periods of time wastes fuel and fouls injector nozzles. Unburned fuel causes carbon formation, oil dilution, formation of lacquer or gummy deposits on the valves, pistons, and rings, and rapid accumulation of sludge in the engine.

NOTE: When prolonged idling is necessary, maintain at least 800 rpm.

Racing The Engine

NEVER race the engine during the warm-up period. NEVER operate the engine beyond governed speed (as might occur in downhill operation or downshifting). Engine bearings, pistons, and valves may be damaged if these precautions are not taken.

hold the OUTRIGGERS EXTEND/RETRACT rocker switch to RETRACT. The chosen outrigger beam should begin to retract.

NOTE: More than one outrigger may be retracted at one time.

- After all outriggers have been fully retracted, stow the outrigger floats. Pin them to their front and rear stowing points with quick pins.

Stowing The Mid-Extend Lock Pin

- Retract the outrigger extension cylinder.

NOTE: If the lock pin is wedged in the hole in the outrigger beam, it may be necessary to jog the OUTRIGGERS EXTEND/RETRACT switch slightly while pulling upward on the pin.

- Lift the lock pin and turn it 90° to its stowed position.

Swinging The Boom (Single Axis Controller Option)



DANGER

Death or serious injury could result from being crushed by moving machinery. Before activating swing, sound the steering wheel horn and verify that all personnel are clear of rotating and moving parts.



WARNING

Keep the areas in the swing path of the hook, load and tail clear of all obstructions and personnel.

CAUTION

Disengage the swing brake and the swing lock pin or 360° swing lock before attempting to swing.

The operator must select the proper load chart and LMI program for the outrigger position selected.

Never push or pull the swing control lever through neutral to the opposite direction to stop swing motion. Use the swing brake foot pedal to stop swing rotation.

NOTE: Automatic rear axle oscillation lockout will activate when the boom swings right or left of the crane centerline.

To swing the turntable right (clockwise), push the SWING control lever forward away from yourself. To swing the turntable left (counterclockwise), pull the swing control lever back, toward yourself. Always operate the control level with a slow, even pressure. Use the swing brake foot pedal to stop

rotation, then position the SWING BRAKE switch to ON to prevent further rotation.

Elevating The Boom (Single Axis Controller Option)



WARNING

Keep the area above and below the boom clear of all obstructions and personnel when elevating the boom.

To elevate the boom, pull the BOOM (lift) control lever back, toward yourself, and hold until the boom reaches the desired elevation level.

Lowering The Boom (Single Axis Controller Option)



WARNING

Keep the area beneath the boom clear of all obstructions and personnel when lowering the boom.

Long cantilever booms can create a tipping condition, even when unloaded and in an extended, lowered position.

CAUTION

When lowering the boom, simultaneously let out the hoist cable to prevent two-blocking the boom nose and hook block.

The closer the load is carried to the boom nose, the more important it becomes to simultaneously let out the hoist cable as the boom is lowered.

To lower the boom, push the BOOM control lever forward, away from yourself, and hold until the boom is lowered to the desired position.

Extending The Boom (Single Axis Controller Option)



WARNING

When extending the boom, simultaneously let out the hoist cable to prevent two-blocking the boom nose and hook block.



DANGER

Check the load chart for the maximum load at a given radius, boom angle, and length before extending the boom with a load.

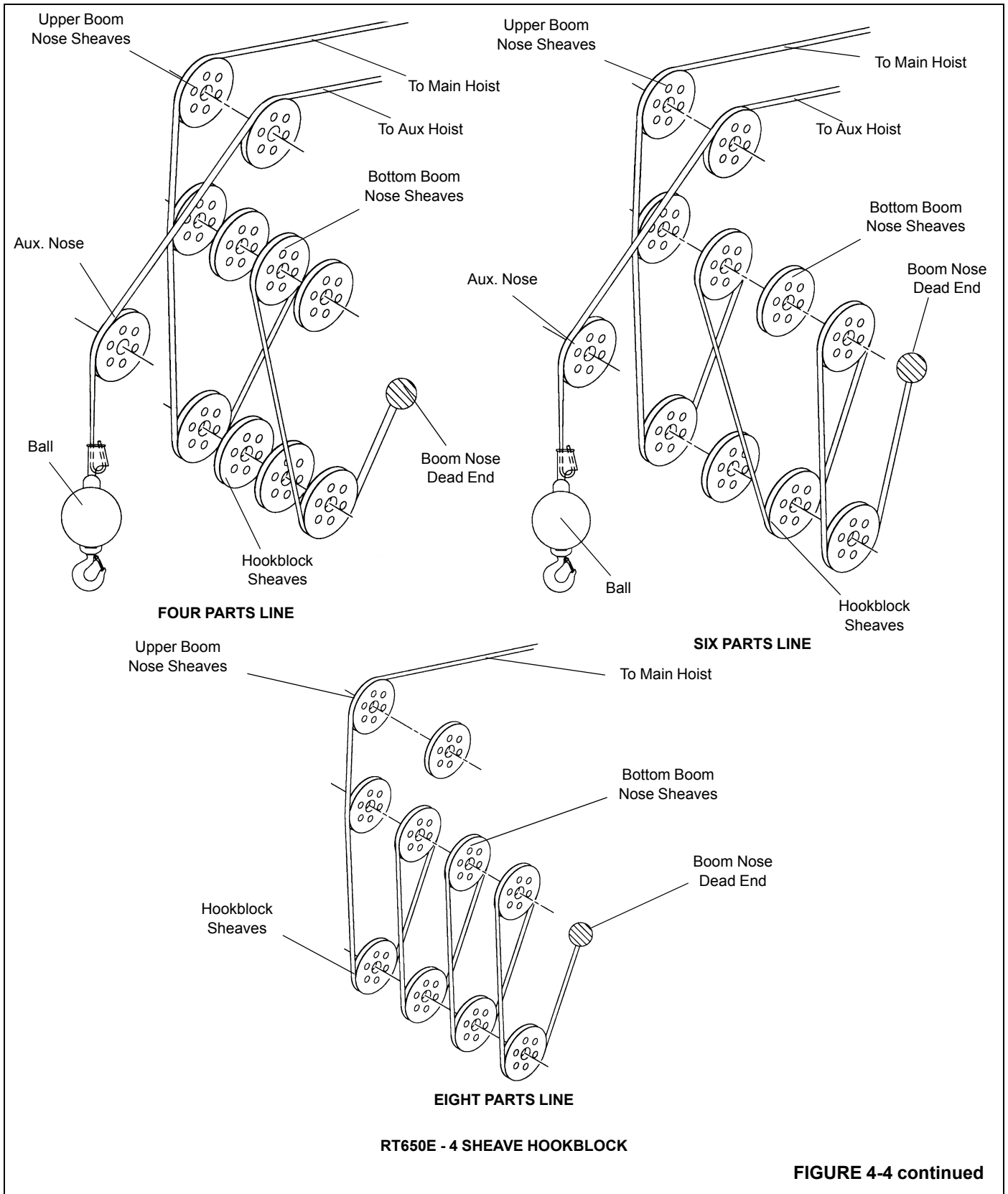

SECTION 5 LUBRICATION

SECTION CONTENTS

General	5-1	Steering and Suspension.....	5-5
Environmental Protection	5-1	Axles	5-7
Lubrication Intervals	5-1	Drive Train	5-9
Arctic Conditions Below 0°F (-18°C).....	5-1	Drive Train (continued)	5-12
Arctic Conditions Down To -40°F	5-2	Turntable	5-14
Surface Protection for Cylinder Rods	5-2	Outriggers	5-16
Wire Rope Lubrication	5-3	Boom	5-18
lubrication points	5-4	Boom (continued)	5-20
CraneLUBE.....	5-4	Hoist.....	5-22
Safety	5-4	Hoist.....	5-24
		Hydraulic	5-26

GENERAL

Following the designated lubrication procedures is important in ensuring maximum crane lifetime and utilization. The procedures and lubrication charts in this section include information on the types of lubricants used, the location of the lubrication points, the frequency of lubrication, and other information.

ENVIRONMENTAL PROTECTION

Dispose of waste properly! Improperly disposing of waste can threaten the environment.

Potentially harmful waste used in Manitowoc cranes includes — but is not limited to — oil, fuel, grease, coolant, air conditioning refrigerant, filters, batteries, and cloths which have come into contact with these environmentally harmful substances.

Handle and dispose of waste according to local, state, and federal environmental regulations.

When filling and draining crane components, observe the following:

- Do not pour waste fluids onto the ground, down any drain, or into any source of water.
- Always drain waste fluids into leak proof containers that are clearly marked with what they contain.
- Always fill or add fluids with a funnel or a filling pump.
- Immediately clean up any spills.

LUBRICATION INTERVALS

The service intervals specified are for normal operation where moderate temperature, humidity, and atmospheric conditions prevail. In areas of extreme conditions, the service periods and lubrication specifications should be altered to meet existing conditions. For information on extreme condition lubrication, contact your local Grove Distributor or Manitowoc Crane Care.

CAUTION

Chassis grease lubricants must not be applied with air pressure devices as this lubricant is used on sealed fittings.

CAUTION

The multipurpose grease installed during manufacture is of a lithium base. Use of a noncompatible grease could result in damage to equipment.

Arctic Conditions Below 0°F (-18°C)

In general, petroleum based fluids developed especially for low temperature service may be used with satisfactory results. However, certain fluids, such as halogenated hydrocarbons, nitro hydrocarbons, and phosphate ester hydraulic fluids, might not be compatible with hydraulic system seals and wear bands. If you are in doubt about the suitability of a specific fluid, check with your authorized Grove distributor or Manitowoc Crane Care.

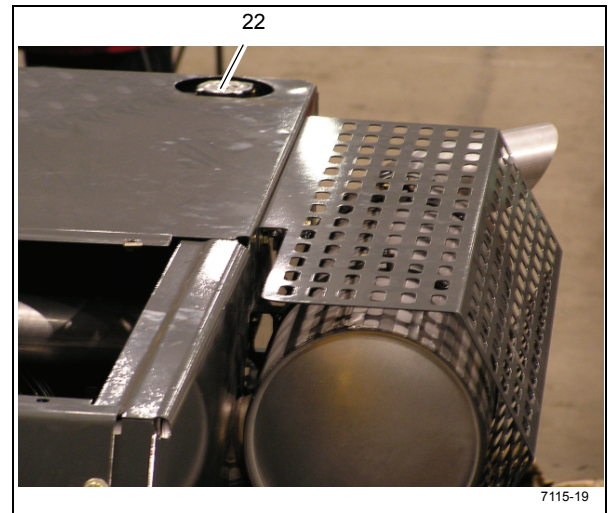
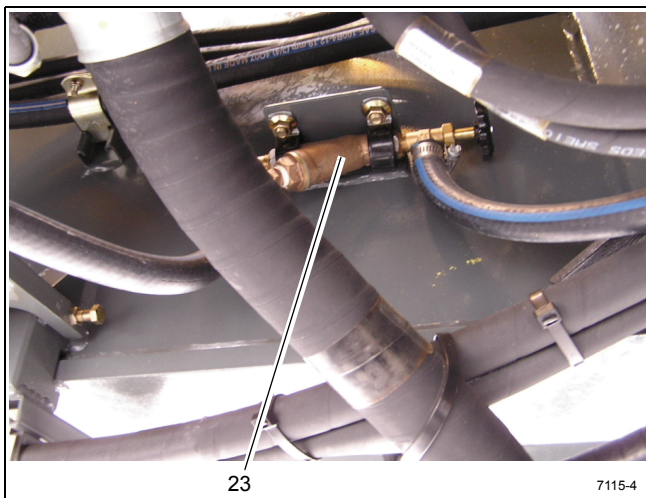
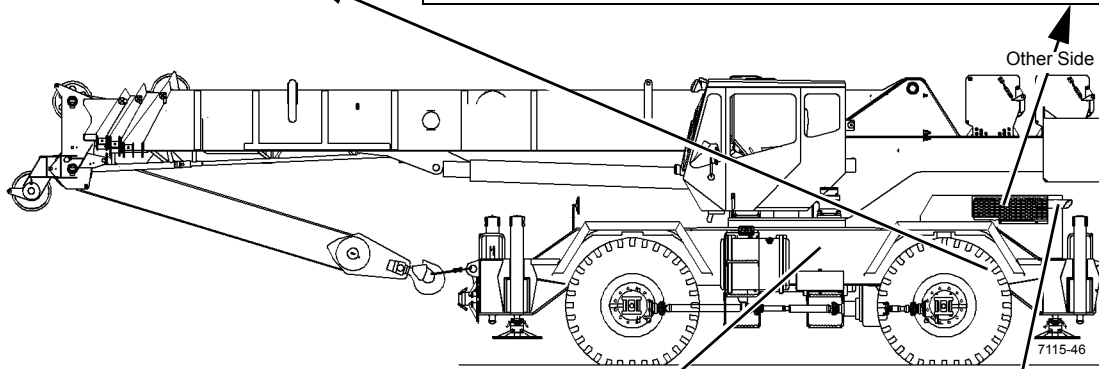
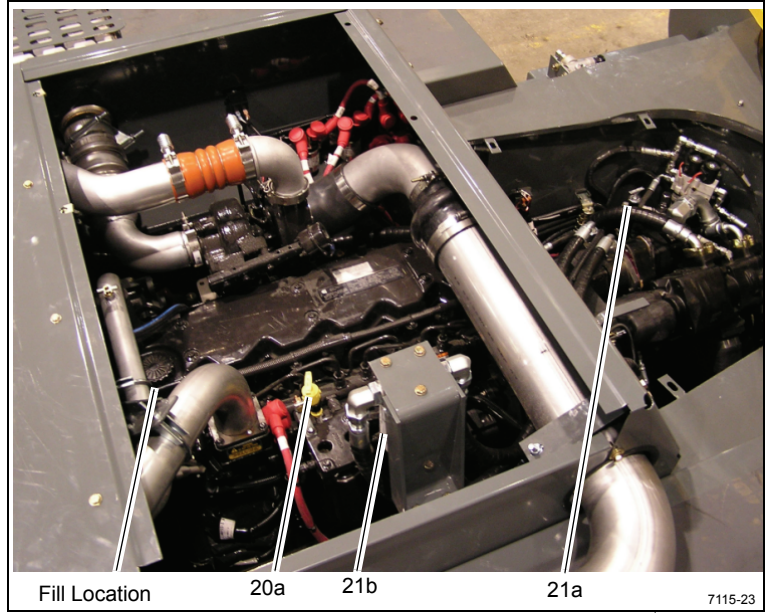

FIGURE 5-3

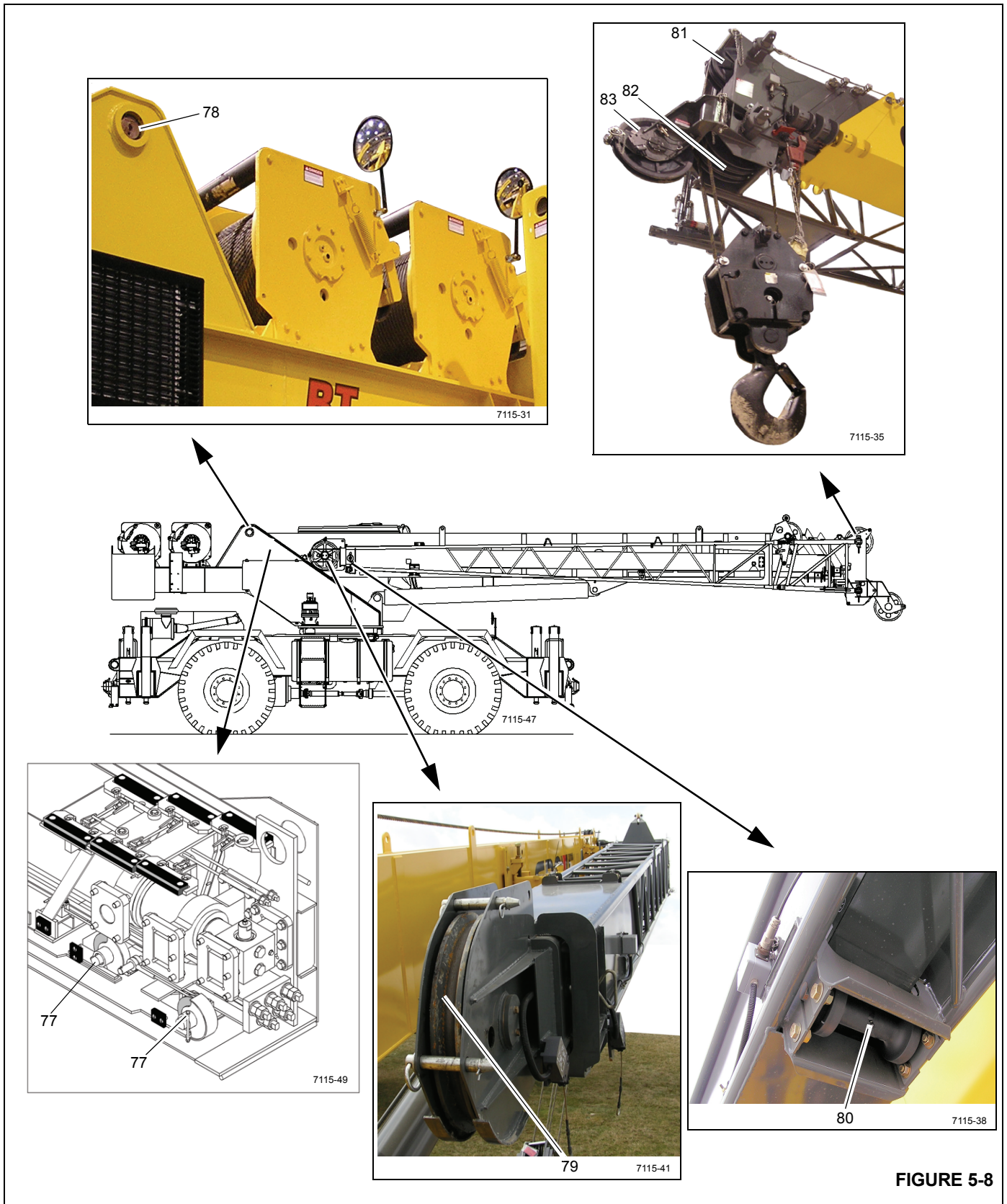

FIGURE 5-8

CLICK HERE TO **DOWNLOAD** THE COMPLETE MANUAL

- Thank you very much for reading the preview of the manual.
- You can download the complete manual from: www.heydownloads.com by clicking the link below



- Please note: If there is no response to CLICKING the link, please download this PDF first and then click on it.

CLICK HERE TO **DOWNLOAD** THE COMPLETE MANUAL