



Operator's Manual

Serial Number Range

S-40 TRAX
S-45 TRAX

from S4513-17603

ANSI/CSA
North America
South America
Asia

with
Maintenance
Information

First Edition
Third Printing
Part No. 217555

CLICK HERE TO **DOWNLOAD** THE COMPLETE MANUAL

- Thank you very much for reading the preview of the manual.
- You can download the complete manual from: www.heydownloads.com by clicking the link below



- Please note: If there is no response to CLICKING the link, please download this PDF first and then click on it.

CLICK HERE TO **DOWNLOAD** THE COMPLETE MANUAL

General Safety

114247



82548



82671

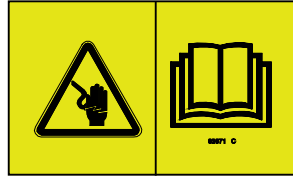

114252



82472



82481



82473



133263

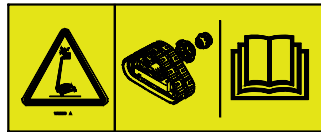

133067

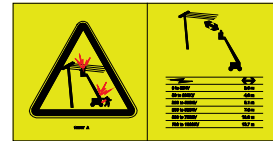

133067

114247

82548

82671

133263

133067

114252

82473

82481

82472

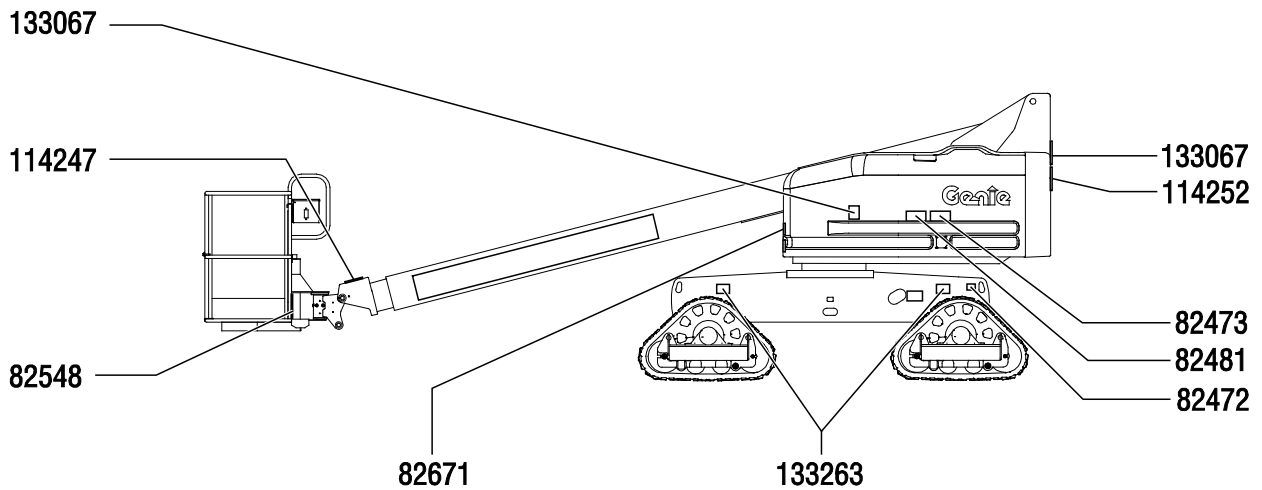

Controls

The S-40 and S-45 machines will have one of these two styles of ground control panel. The descriptions in this section and the instructions in the Function Test and Operating Instructions apply to both panels, unless specifically noted.

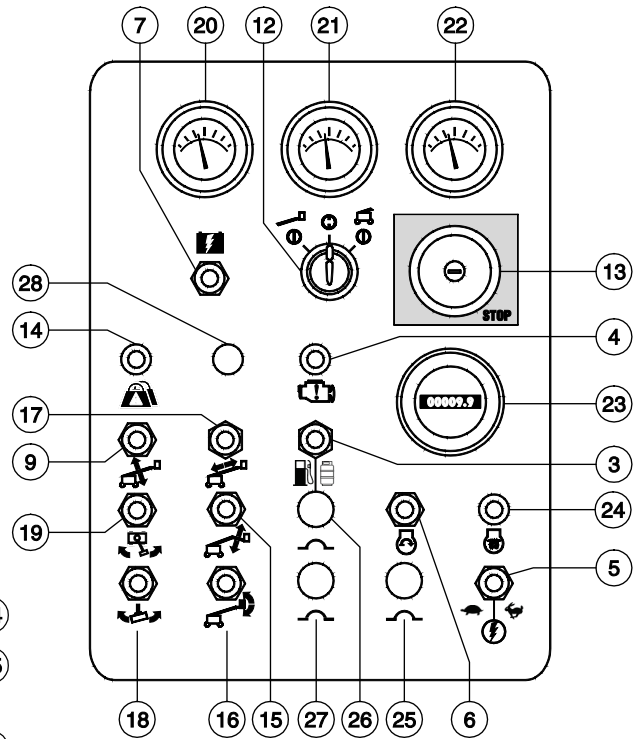
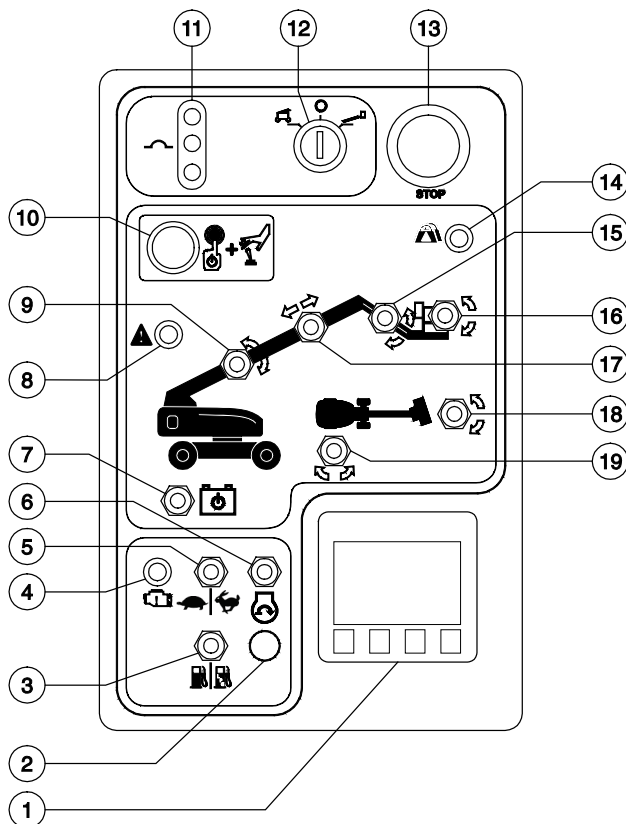

Inspections

Test the Tilt Sensor

- 12 Pull out the platform red Emergency Stop button to the on position. Turn the key switch to platform control.
- 13 Open the tank side turntable cover and locate the tilt sensor next to the control box.
- 14 Press down one side of the tilt sensor.

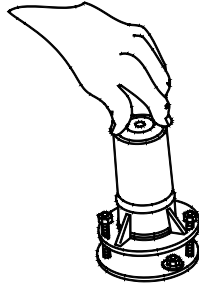

- ⊙ Result: The alarm, located in the platform, should sound.

Test Emergency Controls

- 15 Turn the key switch to ground control and shut the engine off.
- 16 Pull out the red Emergency Stop button to the on position.
- 17 Simultaneously hold the emergency power switch on and activate each boom function toggle switch.



OR



Note: To conserve battery power, test each function through a partial cycle.

- ⊙ Result: All boom functions should operate.

At the Platform Controls

Test Emergency Stop

- 18 Enter the platform and pull out the red Emergency Stop button. Start the engine.
- 19 Push in the platform red Emergency Stop button to the off position.
 - ⊙ Result: The engine should shut off and no functions should operate.
- 20 Pull out the red Emergency Stop button and restart the engine.

Test the Horn

- 21 Press the horn button.
 - ⊙ Result: The horn should sound.

Operating Instructions

Starting the Engine

Gasoline/LPG models

- 1 At the ground controls, turn the key switch to the desired position.
- 2 Be sure both ground and platform control red Emergency Stop buttons are pulled out to the on position.
- 3 Choose fuel by moving the fuel select switch to the desired position.
- 4 Move the engine start toggle switch to either side. If the engine fails to start or dies, the restart delay will disable the start switch for 3 seconds.

Diesel models

- 1 At the ground controls, turn the key switch to the desired position.
- 2 Be sure both ground and platform control red Emergency Stop buttons are pulled out to the on position.

Models with glow plug toggle switch:

- 3 Move the glow plug switch to either side and hold for 3 to 5 seconds.
- 4 Move the engine start toggle switch to either side. If the engine fails to start or dies, the restart delay will disable the start switch for 3 seconds.

Models with automatic glow plugs:

- 5 The LCD screen will display the glow plug symbol when the automatic glow plugs are on.
- 6 When the automatic glow plug symbol turns off, move the engine start toggle switch to either side. If the engine fails to start or dies, the restart delay will disable the start switch for 3 seconds.



Transport and Lifting Instructions

Securing to Truck or Trailer for Transit

Always use the turntable rotation lock pin each time the machine is transported.

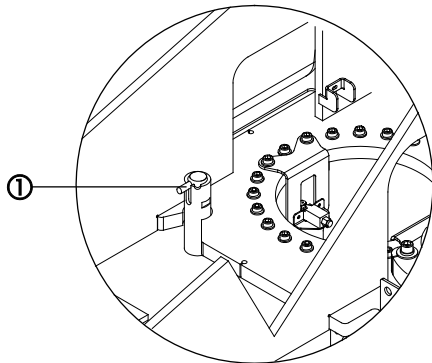

1 Turntable rotation lock pin

Turn the key switch to the off position and remove the key before transporting.

Inspect the entire machine for loose or unsecured items.

Securing the Chassis

Use chains or straps of ample load capacity.

Use a minimum of 5 chains.

Adjust the rigging to prevent damage to the chains.

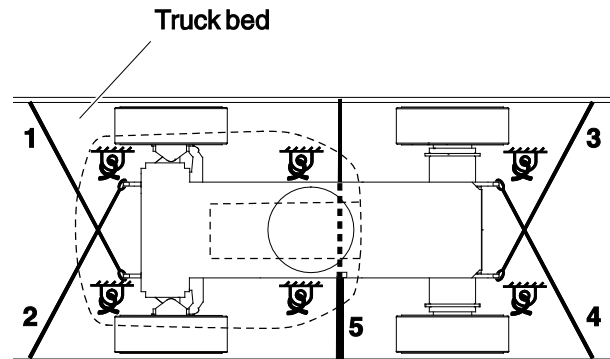

CLICK HERE TO **DOWNLOAD** THE COMPLETE MANUAL

- Thank you very much for reading the preview of the manual.
- You can download the complete manual from: www.heydownloads.com by clicking the link below



- Please note: If there is no response to CLICKING the link, please download this PDF first and then click on it.

CLICK HERE TO **DOWNLOAD** THE COMPLETE MANUAL