

Operator's manual

Part N. **57.0008.3200**
Rev. 0 **09/2006**
From serial n. **15641**
To serial n. **19093**

English
Edition

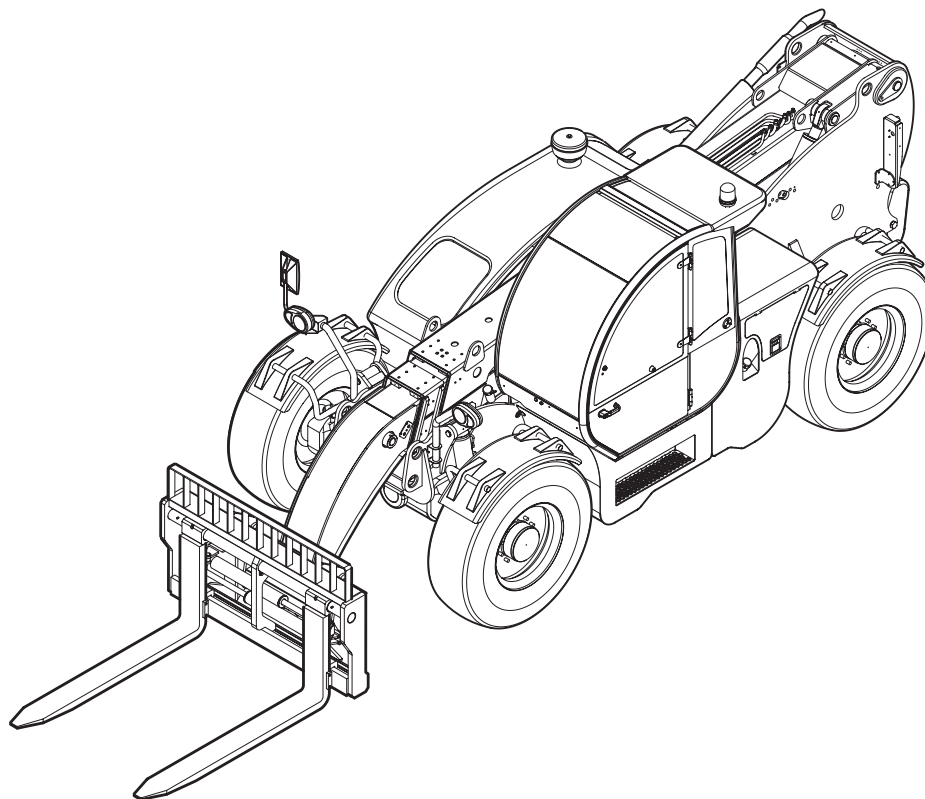

Genie®

A TEREX COMPANY

GTH-4013 SX



CAUTION: THOROUGHLY READ AND UNDERSTAND THIS HANDBOOK BEFORE OPERATING THE MACHINE
CAUTION: KEEP THIS HANDBOOK IN THE MACHINE AT ALL TIMES

CLICK HERE TO **DOWNLOAD** THE COMPLETE MANUAL

- Thank you very much for reading the preview of the manual.
- You can download the complete manual from: www.heydownloads.com by clicking the link below



- Please note: If there is no response to CLICKING the link, please download this PDF first and then click on it.

CLICK HERE TO **DOWNLOAD** THE COMPLETE MANUAL

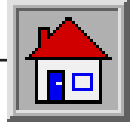

GENERAL INFORMATION

■ A-1.2 LABELS AND WARNING PLATES APPLIED ON THE MACHINE

This paragraph lists the labels and warning plates normally applied on standard machines or on special attachments coupled to the machine.

IMPORTANT

The familiarisation with these labels is never a waste of time.

Make sure they are easy to read. For this purpose, clean them or replace those that become unreadable (either graphic or text).

To clean labels, use of a soft cloth, water and soap. Never use solvents, petrol, etc.

When a label is applied on a part to be replaced, make sure that the replaced part is already labelled as required or apply a new label.

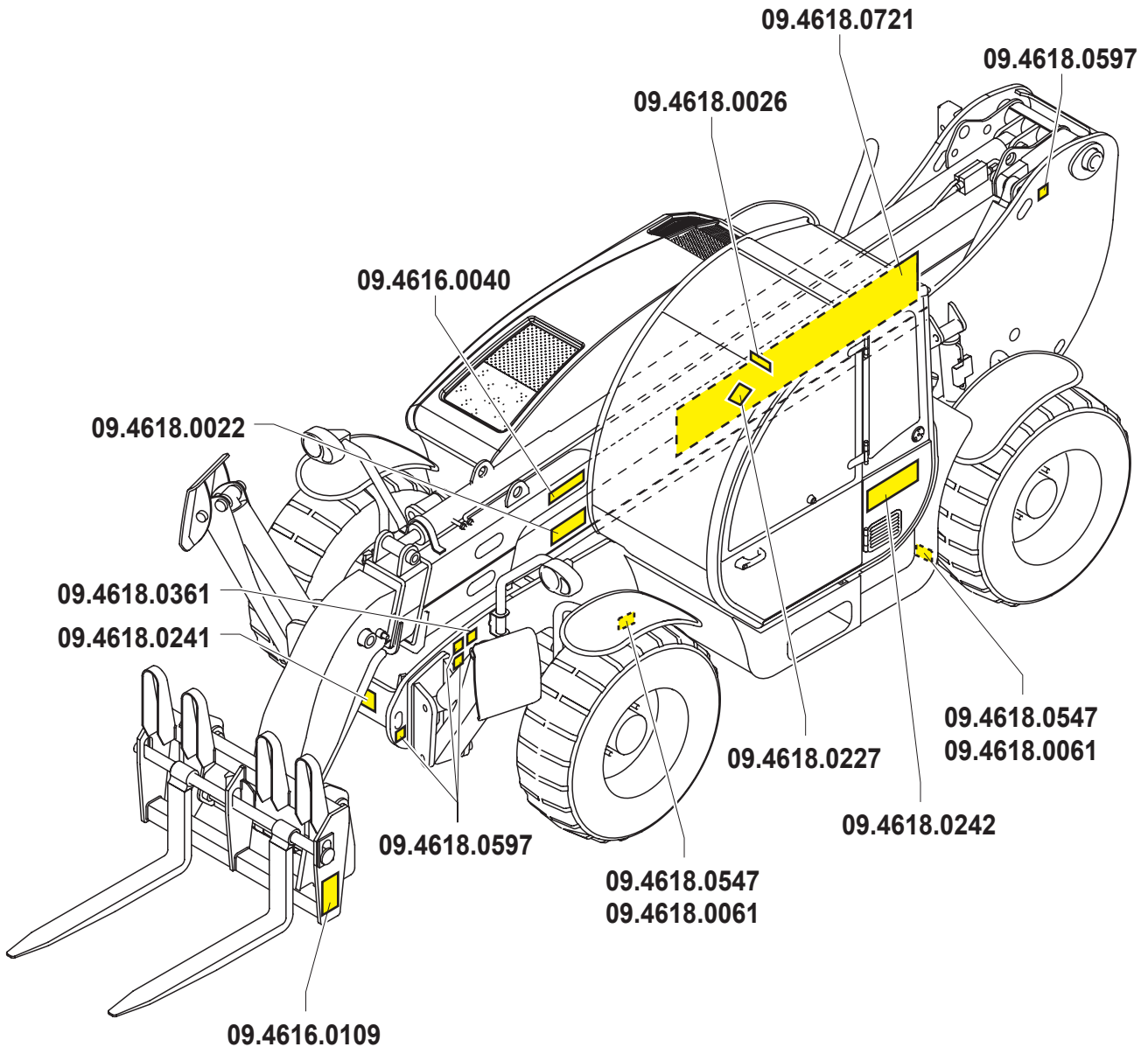

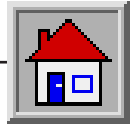

GENERAL INFORMATION

B Road traffic data plate

The road traffic data plate **B** is installed on the front right side of the chassis (only on machines destined for the Italian market).

This plate shows the road traffic related data and the weights of the specific machine model.

C ROPS-FOPS cab type-approval plate

The ROPS - FOPS type-approval plate **C** is located inside the driving cab above the rear glass.

D Fork data plate

Placed on the left side of the fork frame.

This plate shows the identification data of fork such as model, serial number, year of manufacture, weight, nominal payload, centre of the load and model of the machine on which the forks are installed.

A-2.4 CE MARKING

This machine fulfils the safety requirements of the Machinery Directive. The conformity has been certified and the placing of the **CE** marking on the machine demonstrates compliance with the regulatory requirements.

The **CE** marking is placed directly on the identification plate of the machine **A**.

A-2.5 CHASSIS SERIAL NUMBER

The chassis serial number is punched on the front left part of the chassis side member **D**.

A-2.6 IDENTIFICATION PLATES OF THE MAIN PARTS

The plates of the main components, not directly manufactured by **TEREXLIFT srl** (for instance, engines, pumps, etc.), are located where originally applied by the manufacturers.

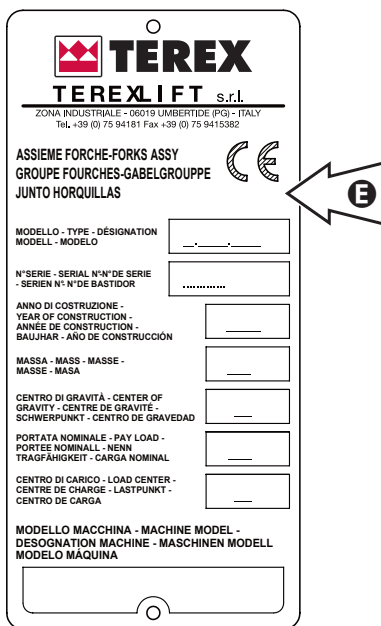
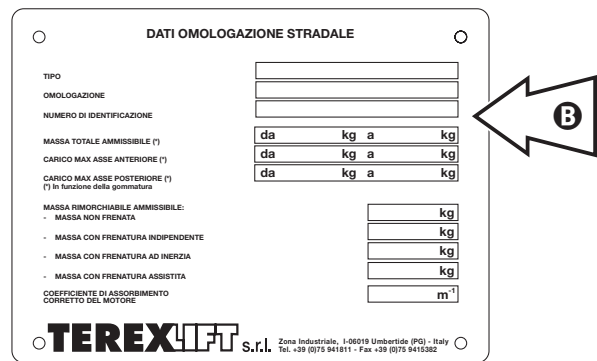
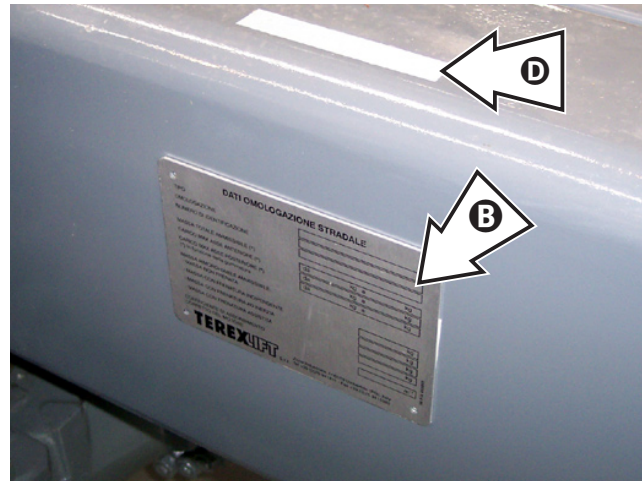

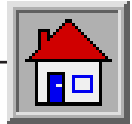

GENERAL INFORMATION

	GTH-4013 SX
■ A-5.5 PAYLOAD AND REACH	
- Max lifting height:	
with outriggers	13000
without outriggers	12810
- Reach at max height without outriggers	650
- Max reach forward with outriggers	9020
- Attachment holding plate rotation	138°
- Maximum payload with outriggers	4000
- Payload at max height with outriggers	3000
- Payload at max reach with outriggers	1250
■ A-5.6 FORKS (FLOATING TYPE)	
- Dimensions	1200x120x50
- Weight	70
- Fork holding frame - class	FEM III
■ A-5.7 DIESEL ENGINE	
	TURBO version
- Make	CUMMINS
- Model/Type	4B 4,5T
- Features:	Diesel
	4 cylinders in line
	4 strokes
	direct injection
- Bore x Stroke	102 x 120
- Total displacement	4500
- Power at 2200 rpm	74
■ A-5.8 ELECTRICAL SYSTEM	
- Voltage	12
- Battery	120
■ A-5.9 MACHINE SOUND LEVELS	
- Guaranteed sound power level (in accordance with the Directive 2000/14/CE)	Lwa =
- Measured sound pressure level (in accordance with the Directive 98/37/CE)	Lpa =
■ A-5.10 VIBRATION LEVELS	
- Mean assessed vibration level transmitted to arms	< 2.5
- Mean assessed vibration level transmitted to body	< 0.5
Values calculated in accordance with standard prEN13059	

IMPORTANT

This is a Class A device. In a residential environment, such device can cause radio disturbance. In such cases, the operator is required to take suitable measures.

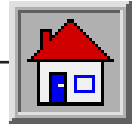

OPERATING INSTRUCTIONS

Section C

OPERATING INSTRUCTIONS

TABLE OF CONTENTS

C-1	PRE-OPERATION INSPECTION	C-2	C-4	SETUP.....	C-25
C-2	ENTERING THE MACHINE	C-4	C-4.1	Before starting the engine	C-25
C-2.1	Entering the cab	C-4	C-4.1.1	Checks at the machine start-up.....	C-25
C-2.1.1	Emergency exit-way	C-4	C-4.2	Starting the engine	C-25
C-2.2	Adjusting the seat.....	C-5	C-4.3	Jump-starting the engine	C-26
C-2.3	Fastening the seat belts	C-5	C-4.4	Low temperature starting.....	C-27
C-2.4	Adjusting the steering column	C-6	C-4.5	Starting the machine.....	C-28
C-2.5	Adjusting the rear view mirrors	C-6	C-4.6	Stopping and parking the machine	C-28
C-2.6	Switching on the cab interior lamp.....	C-6	C-5	USING THE HANDLER	C-29
C-3	DRIVING PLACE.....	C-7	C-5.1	Using the load charts.....	C-30
C-3.1	Controls and instruments.....	C-7	C-5.2	Load limiter	C-31
C-3.2	Engine controls and instruments	C-9	C-5.2.1	Description of the controls	C-31
C-3.2.1	Ignition switch	C-9	C-5.2.2	Operation.....	C-31
C-3.2.2	Forward/reverse gear switch	C-9	C-5.2.2	Alarm codes and resetting.....	C-32
C-3.2.3	Turn signals - windscreen wiper - lights - horn switch.....	C-10	C-5.3	Handling loads.....	C-33
C-3.2.4	Brakes	C-11	C-5.3.1	Adjusting the forks	C-33
C-3.2.5	Accelerator control.....	C-11	C-5.3.2	Working phases.....	C-34
C-3.2.6	Steering mode selection.....	C-12	C-5.4	Changing the optional attachment.....	C-35
C-3.2.7	Road/Jobsite switch.....	C-13	C-6	TRANSPORTING THE MACHINE	C-37
C-3.3	Instruments and warning lights.....	C-14	C-6.1	Moving a disabled machine	C-37
C-3.3.1	Instruments.....	C-14	C-6.1.1	Dismantling the Cardan shaft	C-37
C-3.3.2	Warning lights.....	C-15	C-6.2	Road or site transfer.....	C-38
C-3.4	Control lever	C-16	C-6.3	Lifting the machine	C-39
C-3.4.1	Function selection.....	C-17	C-6.4	Transporting the machine	C-39
C-3.4.2	Emergency stop.....	C-18	C-6.4.1	Transporting the machine on other vehicles.....	C-39
C-3.4.3	Disabling the overload warning system	C-18	C-6.5	Parking and storage	C-40
C-3.4.4	Lifting/lowering the boom.....	C-19	C-6.5.1	Short inactivity	C-40
C-3.4.5	Extending/retracting the boom.....	C-20	C-6.5.2	Machine storage	C-40
C-3.4.6	Pitching the attachment holding frame forward/back.....	C-21	C-6.6	Cleaning and washing the machine.....	C-41
C-3.4.7	Quick-coupling the attachments	C-22	C-6.6.1	Cleaning instructions	C-41
C-3.5	Machine sway control	C-23	C-6.6.2	Washing instructions.....	C-41
C-3.6	Outrigger control.....	C-24	C-6.7	Machine disposal.....	C-41
			C-6.7.1	Disposal of batteries	C-41

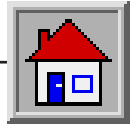

OPERATING INSTRUCTIONS

■ **C-3.2.4 Brakes**

27 Service brake pedal

Gradually step on the brake pedal to decelerate and stop the machine. The pedal operates on the rear axle.

31 Parking brake

To engage the parking brake, pull the lever upward while holding the locking button pressed down. Release the button when reaching the required braking tension. It operates on the axle shafts of the rear axle and, when engaged, it cuts both forward and reverse gear off.

■ **C-3.2.5 Accelerator control**

26 Gas pedal

Its pressure controls the engine rpm and the machine speed. It is fitted with an adjustable stop in the lower part.



Never use the parking brake to slow down the machine, unless in an emergency. It may reduce the brake efficiency.

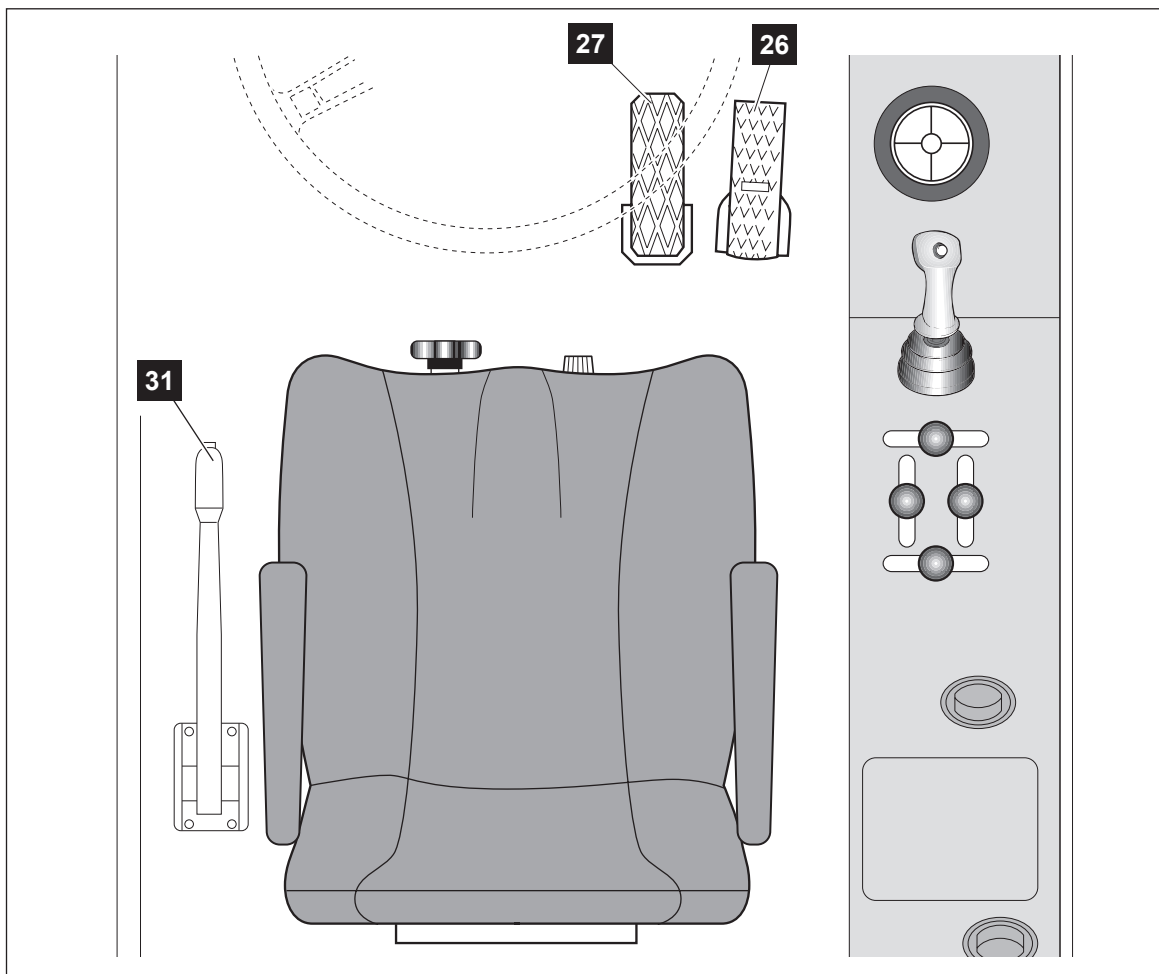

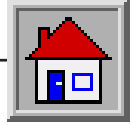

OPERATING INSTRUCTIONS

■ C-3.4.6 Pitching the attachment holding frame forward/back



DANGER

Before operating the boom, make sure that nobody is within the working range of the machine.

To tilt forward/back the attachment holding frame:

- Press the button ① on the joystick
- Smoothly shift the lever to position **D** to pitch the holding frame forward or to position **C** to pitch the holding frame back.

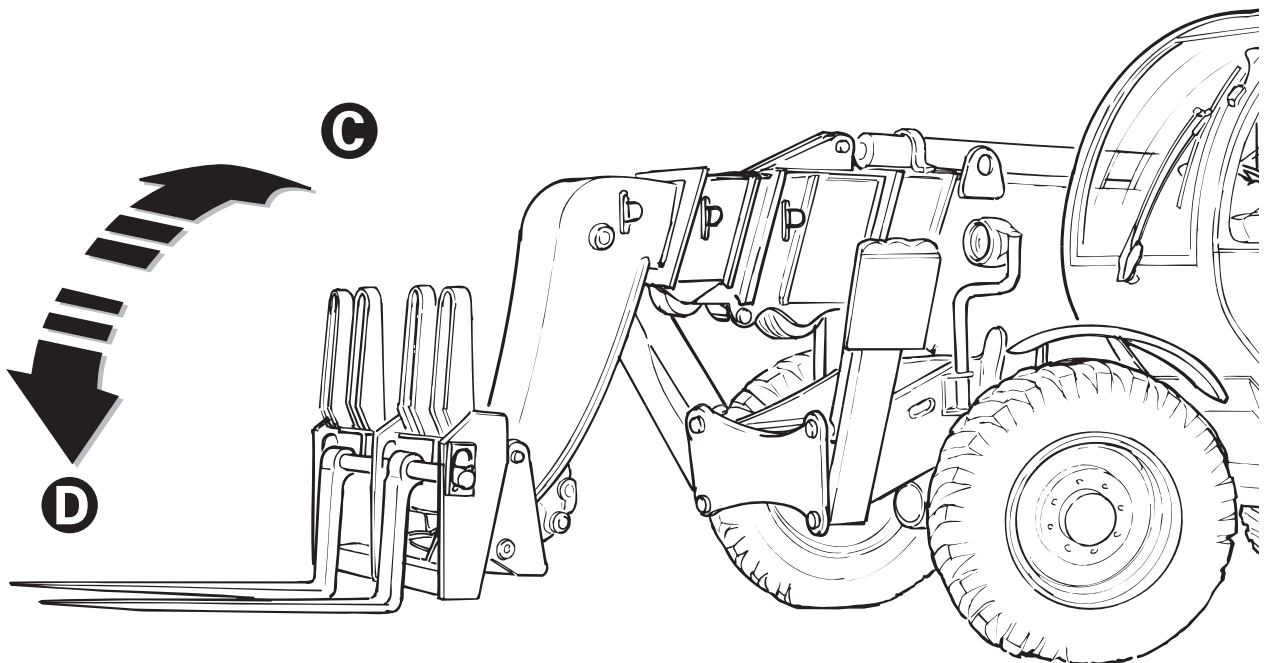
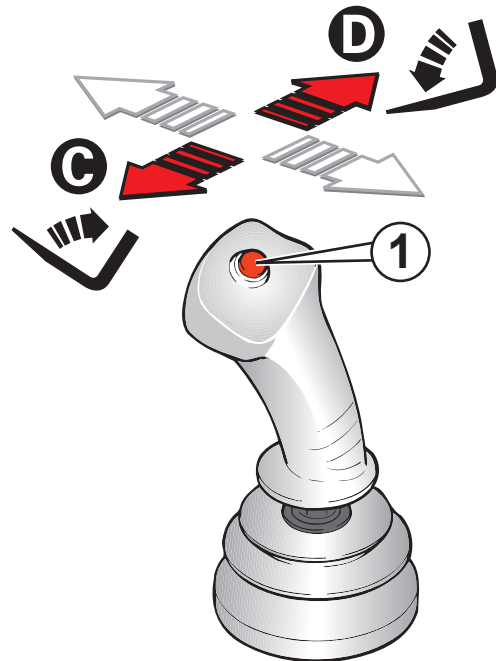

CLICK HERE TO **DOWNLOAD** THE COMPLETE MANUAL

- Thank you very much for reading the preview of the manual.
- You can download the complete manual from: www.heydownloads.com by clicking the link below



- Please note: If there is no response to CLICKING the link, please download this PDF first and then click on it.

CLICK HERE TO **DOWNLOAD** THE COMPLETE MANUAL



OPERATING INSTRUCTIONS

■ **C-5.2 LOAD LIMITER**

On the front top strut of the cab, there is limiter **34** which warns the operator of the variation of stability of the machine and blocks any manoeuvre before the same reaches a critical condition.

■ **C-5.2.1 Description of the controls**

- 1 Calibration selection button
- 2 Display
- 3 Stability indicator with LED-bar
- 4 Green light - power OK
- 5 Yellow light - calibration mode
- 6 Calibration confirmation button
- 7 Not used
- 8 Red light - outrigger position
- 9 Buzzer ON/OFF pushbutton
- 10 Red light - overload pre-alarm/alarm

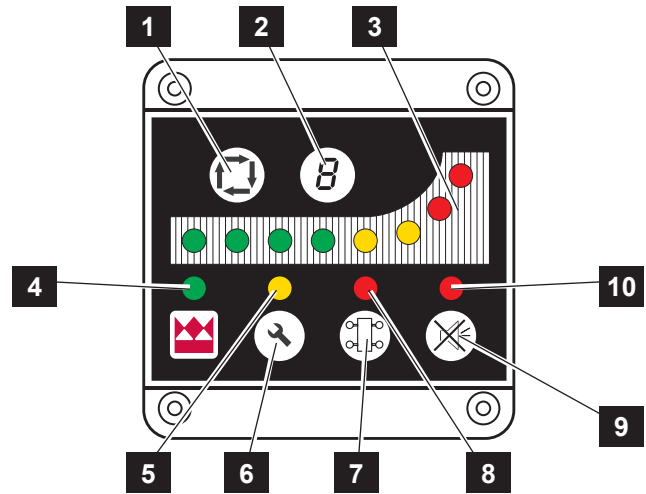

The digit on display **2** shows the selected attachment. The user can choose among:

0: Generic

■ **C-5.2.2 Operation**

When power is turned on, light **4** comes on. The display **2** remains off and the monitoring system runs a self-test before displaying the digit corresponding to the used attachment on display **2**. At this time, the system is activated.

During operation, the led-bar **3** lights up gradually depending on the variation of stability.

Green LED's: during normal operation when the percentage of overturning moment is between 0 and 89, these LED's are ON. The machine is stable.

Yellow LED's: they light up when the machine tends to overturn and the percentage of overturning moment with respect to the threshold value is between 90 and 100. The system enters the **pre-alarm** mode, light **10** flashes and the buzzer sounds with an intermittent sound.

Red LED's: risk of overturning: the percentage of overturning moment is above 100 with respect to the threshold value. The machine enters the **alarm** mode: light **10** is lit, the buzzer sounds continuously and any dangerous manoeuvre is blocked. The operator can only retract the load within safety limits.

Example of use of the overload warning system

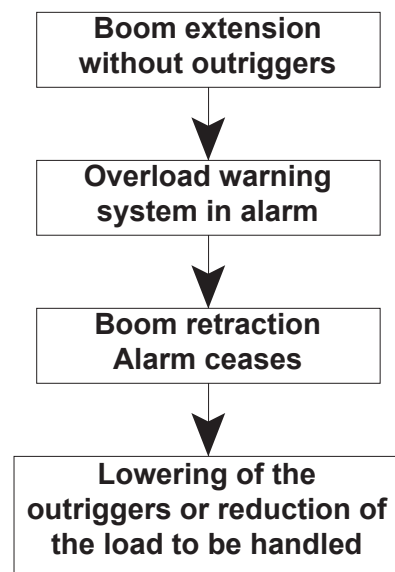

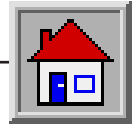

OPERATING INSTRUCTIONS

■ **C-6.6 CLEANING AND WASHING THE MACHINE**

■ **C-6.6.1 Cleaning instructions**

Clean the machine in accordance with the following instructions:

- Remove any oil or grease traces with a dry solvent or a volatile mineral alcohol
- Before assembling a new part, remove any protection product (rust-preventer, grease, wax etc.).
- Remove any trace of rust from metal parts with some emery cloth before smearing the part with a protection product (rust-preventer, paint, oil etc.).

■ **C-6.6.2 Washing instructions**

ATTENTION

Do not use water at high pressure for washing the machine and especially the main valve, the solenoid valves and electrical parts.

External washing

Before washing the machine, check that the engine is shut down and the doors and windows are closed. Do not, at any times, use fuel to clean the machine. Use water or some steam. In cold climates, dry the locks after washing or smear them with an antifreeze. Before using the machine again, check its conditions.

Internal washing

Wash the machine interior with some water and a sponge. Do not use water at high pressure. After washing, dry with a clean cloth.

Washing the engine

Before washing the engine, protect the air intake filter to prevent water from entering the circuit.

ATTENTION

If the machine shall be used in a marine or equivalent environment, protect it against salt deposits with an adequate treatment against saltiness to prevent rust formation.

■ **C-6.7 MACHINE DISPOSAL**



PROTECT THE ENVIRONMENT

At the end of the machine life, call in a specialised firm to dispose of it in compliance with the local or national regulations.

■ **C-6.7.1 BATTERY DISPOSAL**



PROTECT THE ENVIRONMENT

Used lead-acid batteries cannot be disposed of as normal industrial solid wastes. Because of the presence of harmful substances, they must be collected, eliminated and/or recycled in accordance with the laws of the UE.

In Italy, used or discarded batteries have been classified as "Toxic wastes" in accordance with Presidential decree n. 397 of 09/09/1988 and Law n. 475 O.G. n. 18 of 09/11/1988 because they contain lead and sulphuric acid. Their disposal through recycling must be done only through companies authorised and belonging to the "Consorzio Obbligatorio Batterie Esauste e dei rifiuti piombosi" (Cobat) which collect and dispose of used lead-acid batteries throughout the national territory.

Used batteries must be kept in a dry and confined place. Make sure the battery is dry and the cell plugs are tight. Place a sign on the battery to warn of not using it. If before disposal the battery is left in the open air, it will be necessary to dry, smear the box and the elements with a coat of grease and tighten the plugs. Do not rest the battery on the ground; it is always advisable to rest it on a pallet and cover it. The disposal of batteries shall be as rapid as possible.

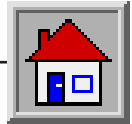

MAINTENANCE

■ **D-3.3 TYRES AND WHEELS**



DANGER

Over-inflated or overheated tyres can burst. Do not flame-cut or weld the wheel rims. For any repair work, call in a qualified technician.

OKAY

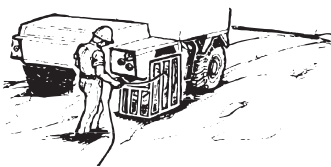

WRONG

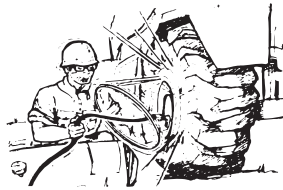

For the tyre inflation or substitution, please refer to the table below:

	GTH-4013 SX	
	STANDARD	OPTIONAL
Dimensions (front and rear)	405/70-20	405/70-24
P.R. (or load index)	14 pr	14 pr
Rim	13x20	13x24
Wheel disc	8 holes DIN 70361	
Pressure bar/Psi	5.5/80	4.5/65



SERVICE INTERVAL

Running-in _____ **Within the first 10 hours**

Ordinary _____ **Every 250 hours**

On new machines, and when a wheel has been disassembled or replaced, check the nut torque of the wheels every 2 hours until they stay correct.

Torque: 400 N/m.

IMPORTANT

Always use tyres having the dimensions indicated in the vehicle registration card.

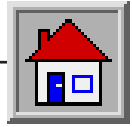

MAINTENANCE

■ D-3.15 ADJUSTING THE SLIDING PADS OF THE BOOM SECTIONS



Any boom section is fitted with adjustable pads located on the four sides of the profile. These pads are secured to both fixed and mobile part of every section.

All pads can be adjusted by the special shims supplied by GENIE upon demand.

Adjusting the pads:

- Remove or loosen the screws fixing the pads in relation to type of shims used (with or without slots).
- Fit the necessary amount of shims.
- If the residual thickness of the pad is insufficient or near the maximum wearing limit, renew the pad.
- Tighten the screws fixing the pads at the recommended torque (see below). Use a dynamometric wrench.

Tightening torques of the pad screws in relation to the screw diameter

Screws M10	Nm 30
Screws M14	Nm 50

Tightening torques higher than those recommended can cause the break of the pad or of the locking threaded bush.

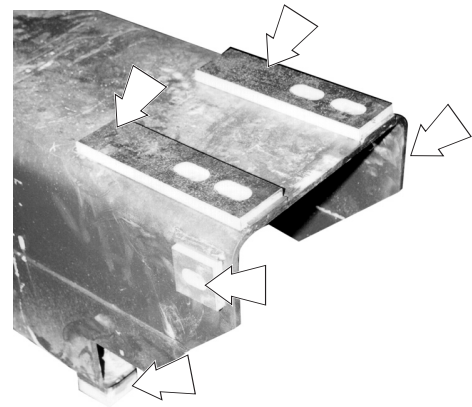
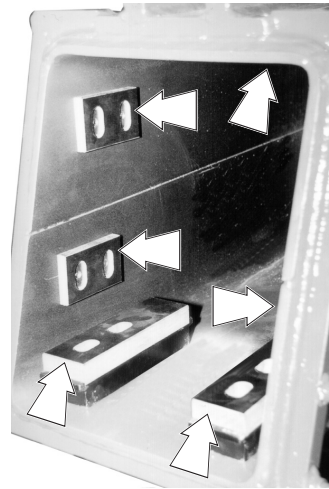

ATTENTION

Pads must compulsorily be replaced if the residual thickness of the plastic layer with respect to the iron bush fixing the block is equal or inferior to 1 mm.

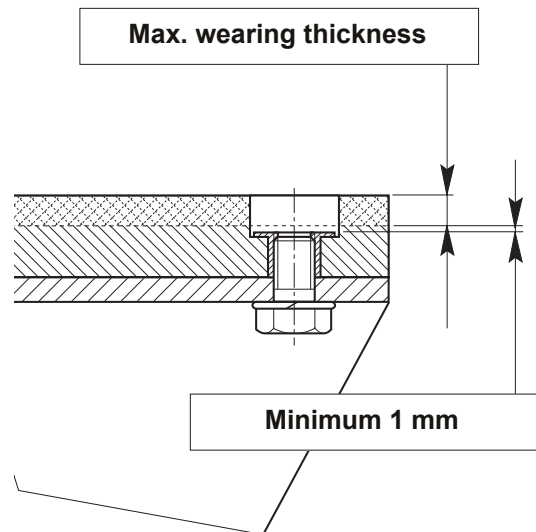

SERVICE INTERVAL

Running-in _____ None

Ordinary _____ When necessary

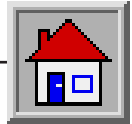

MAINTENANCE

■ **Engine compartment fuses and relays**

Ref.	Circuit	Amp.
F2G	MAIN FUSE	50
F3G	MAIN FUSE	50
Rxx	RELAY	70

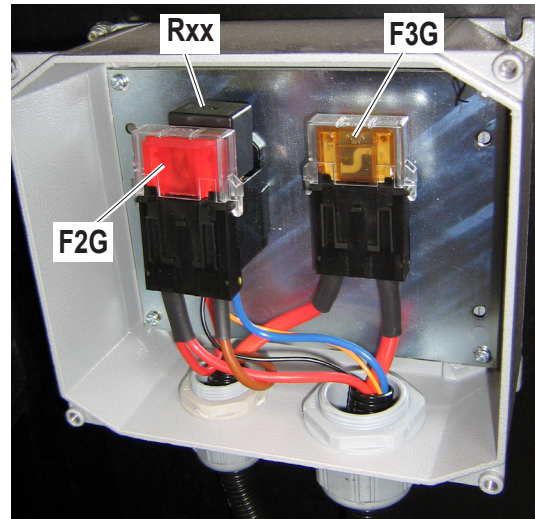

■ **Relays**

Ref.	Circuit
K02	RELAY - PRE-HEATING
K1	RELAY - HIGH BEAM
K2	RELAY - LOW BEAM
K3	RELAY - HORN
K4	RELAY - OPTIONAL
K7	RELAY - FORWARD SPEED
K8	RELAY - REVERSE SPEED
K9	RELAY - TRANSMISSION DISCONNECTED
K10	RELAY - TRANSMISSION DISCONNECTED
K11	RELAY - START-UP ENABLING COMMAND
K14	RELAY - DEADMAN
K18	RELAY - LOW BOOM SENSOR
K19	RELAY - OVERLOAD WARNING SYSTEM
K21	RELAY - D.F.E.
K23	INTERMITTENCE
K610	OVERLOAD WARNING SYSTEM TEMP.
K600	RELAY - FRONT WORK LIGHTS

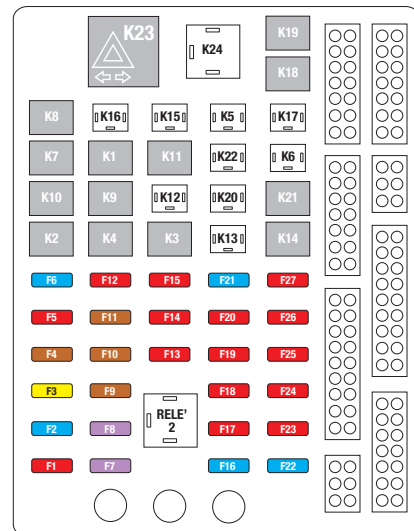

ATTENTION

- *Do not use fuses having a higher amperage than that recommended, since they can damage the electric system seriously.*
- *If the fuse blows after a short time, look for the fault source by checking the electric system.*
- *Always keep some spare fuses for an emergency.*
- *Never try to repair or short blown fuses.*
- *Make sure the contacts of fuses and fuse-sockets ensure a good electric connection and are not oxidised.*

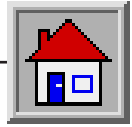

OPTIONAL ATTACHMENTS

■ **F-1.1 SHOVEL**

	Capacity	Code
GTH-4013 SX	Litres 800	59.0202.2000

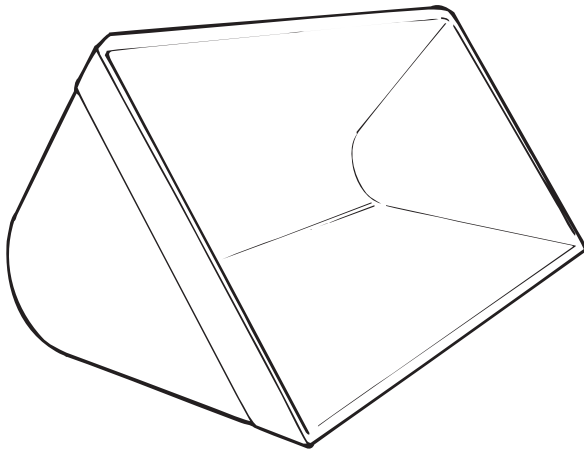

Application

Quick-coupling fitted attachment for moving soil, sand, debris, cereals, etc.

Safety

Strictly obey the general safety precautions given in section **B** "SAFETY".

Operation

ATTENTION

When using a shovel, load the material only when the boom is completely retracted and push against the heap with straight wheels.

To load/unload the material, operate the rotation lever of the attachment holding plate.

Maintenance

Visually check the shovel for damage before using it.

Technical data

	Litres	800
Width	mm	2250
Length	mm	1000
Height	mm	940
Weight	kg	380
SAE capacity	m ³	0,8

ATTENTION

Attachment suitable for moving loose material. Do not use for digging operations.

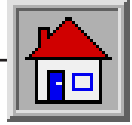

■ **G-3.1.1** Load limiting system wiring diagram - Layout

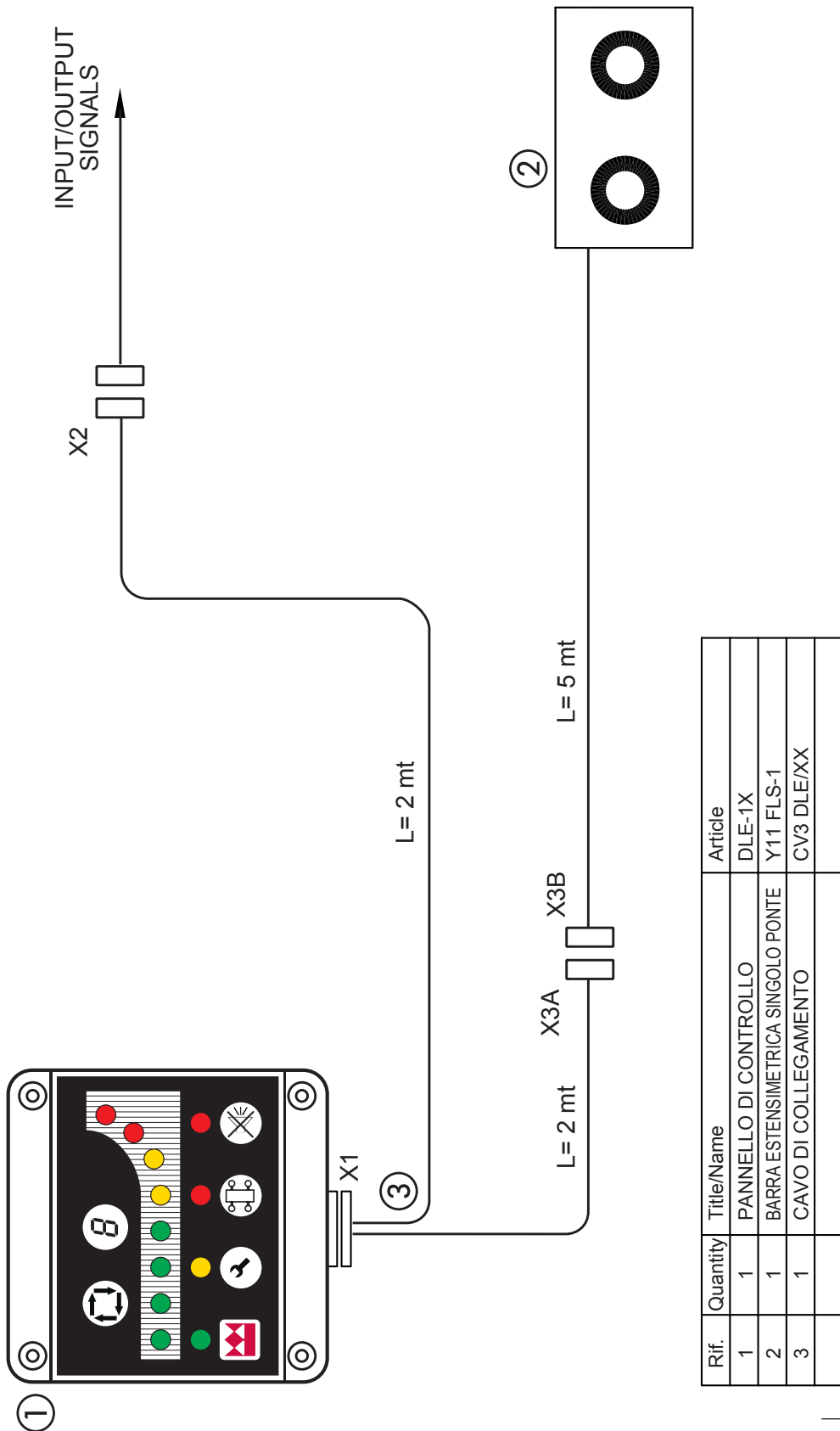

Rif.	Quantity	Title/Name	Article
1	1	PANNELLO DI CONTROLLO	DLE-1X
2	1	BARRA ESTENSIMETRICA SINGOLO PONTE	Y11 FLS-1
3	1	CAVO DI COLLEGAMENTO	CV3 DLE/XX

CLICK HERE TO **DOWNLOAD** THE COMPLETE MANUAL

- Thank you very much for reading the preview of the manual.
- You can download the complete manual from: www.heydownloads.com by clicking the link below



- Please note: If there is no response to CLICKING the link, please download this PDF first and then click on it.

CLICK HERE TO **DOWNLOAD** THE COMPLETE MANUAL