



A TEREX BRAND

Operator's Manual

Serial number range

GTH-1256 (Perkins Tier 4i) From GTH1216M-181 to GTH12M-280

GTH-1256 (Deutz Tier 4i) From GTH1216M-181 to GTH12M-280

Original Instructions

Second Edition

Second Printing

April 2017

Part No. 57.0009.0662

CLICK HERE TO **DOWNLOAD** THE COMPLETE MANUAL

- Thank you very much for reading the preview of the manual.
- You can download the complete manual from: www.heydownloads.com by clicking the link below



- Please note: If there is no response to CLICKING the link, please download this PDF first and then click on it.

CLICK HERE TO **DOWNLOAD** THE COMPLETE MANUAL

Work Area Safety

⚠ Traveling on Slopes Hazards

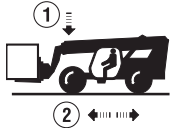

When driving, keep the boom at or below horizontal and keep the load close to the ground.

When the machine is loaded, always travel with the load uphill. When the machine is unloaded, travel with the forks or attachment downhill.

On steep terrain, drive only up and down a hill, and always keep the machine in gear. Do not turn across the slope when the machine is traveling up or down a slope.

Limit travel path and speed according to the condition of the ground surface, traction, slope, location of personnel and any other factors which may create a hazard. Never drive the machine unless the mast and equipment are in their proper travel position. Whether a machine will tip over during dynamic machine operation involves many factors that need to be considered. Among these are pavement/ground conditions, stability and slope, as well as machine equipment, operator skill, load position, tire inflation, machine speed, etc.

Additionally, tip-over of a machine is dependent in large part upon operator inputs such as the speed and smoothness of the operation, as well as the position of the attachment and its load.

Construction sites and roads will frequently change slope from place to place, can be hard and soft, and change due to construction activities and weather.

Operators should be properly trained and use their best judgment and experience to take the necessary precautions to prevent a tip-over.

Operators must assess the job site variables and avoid exceeding the machine's (or operator's) capabilities for terrain and conditions.

⚠ Fall Hazards



Always wear a seat belt when operating the machine.

Always remain completely inside the cab when operating the machine.

When getting in and out of the cab, face the machine, use the steps and handrails provided and always maintain three-point contact.

Do not use the steering wheel or any other controls as handrails.



Do not allow riders on the machine or forks.



Do not lift personnel with this machine unless it is equipped with an approved work platform.

Controls

1 Low engine oil pressure indicator light

When illuminated this light indicates that the engine oil pressure is too low which can lead to machine damage. Discontinue use of the machine and service.

3 Hydraulic oil filter clogged indicator light

When illuminated this light indicates that the hydraulic oil filter is clogged which can lead to machine damage. Discontinue use of the machine and service.

4 Low hydraulic oil level indicator light

When illuminated this light indicates that the hydraulic oil level is too low which can lead to machine damage. Replenish and eliminate the oil leak.

7 Diesel particulate filter indicator light

When illuminated this light indicates that the DPF is in need of regeneration. Park the machine in a safe location, press the DPF switch and refer to the DPF regeneration instructions in the supplemental operator's manual.

10 Engine air filter restricted indicator light

When this lamp comes on, the engine air filter is clogged proceed with cleaning or changing the air filter cartridge.

11 DPF Alert indicator light

This light flashes to warn of a problem of the engine. To identify the problem, see the two sections "Engine Lamp Logic"

12 Engine Critical Fault indicator light

This light comes on to warn of a problem of the engine. To identify the problem, see the two sections "Engine Lamp Logic"

15 High engine coolant temperature gauge

When gauge reaches red, the engine coolant is too hot which can lead to engine damage. Discontinue use and service the engine

19 High hydraulic oil temperature indicator light

This indicates the temperature of the hydraulic oil in the tank which can lead to machine damage. Discontinue use of the machine and service.

22 Brake pressure low indicator light

It lights when the pressure of the braking circuit is too low for a correct functioning which can lead to machine damage. Discontinue use of the machine and service.

Operating Instructions

Parking Brake

Use the parking brake switch to apply the parking brake before raising the boom or leaving the machine.

Push the top of the rocker switch to turn the parking brake on.

Push the bottom of the switch to turn the parking brake off.

Brake Pedal

Use the brake pedal to control the machine speed and to stop the machine motion.

Push and hold the brake pedal to stop the machine.

Push and release the brake pedal to control the machine speed.

Starting the Engine

- 6 Be sure the parking brake is set and the transmission control lever is in the neutral position.
- 7 Insert the key in the ignition switch.

Turn the key until the engine starts.

If the engine fails to start after 30 seconds of cranking, determine the cause and repair any malfunction. Wait 120 seconds before trying to start again.

Starting in Cold Condition

In cold conditions, 20°F / -6°C and below, warm the engine for 5 minutes before operating to prevent hydraulic system damage.

In extreme cold conditions, 0°F / -18°C and below, machines should be equipped with optional cold start kits. Attempting to start the engine when temperatures are below 0°F / -18°C may require the use of a booster battery.

Raising and Lowering the Stabilizers

Push the top of the rocker switch to extend/lower the stabilizers. Push the bottom of the rocker switch to raise/retract the outrigger.

Steer Select

Always position all wheels in line with the machine before switching the steering mode.

Do not realign the wheels while driving.

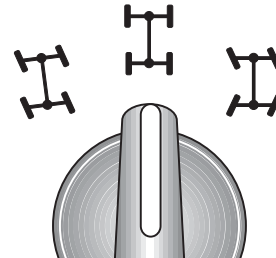

Transport and Lifting Instructions

Securing to Truck or Trailer for Transit

Turn the key switch to the off position and remove the key before transporting.

Inspect the entire machine for loose or unsecured items.

Be sure the door and the door windows are latched and secured (if equipped).

Prior to loading, level the telehandler and retract the boom.

Retract the stabilizers.

Use a spotter to load and unload the telehandler. Keep the boom as low as possible when loading and unloading.

Set the parking brake.

Securing the Chassis

Use chains of ample load capacity.

Use a minimum of 6 chains. There are 8 tie down points on the chassis, two in the front and three on each side of the machine.

Fully lower the forks or attachment onto the truck bed. Secure the forks or attachment with a suitable strap or chain to prevent movement.

Adjust the rigging to prevent damage to the chains.

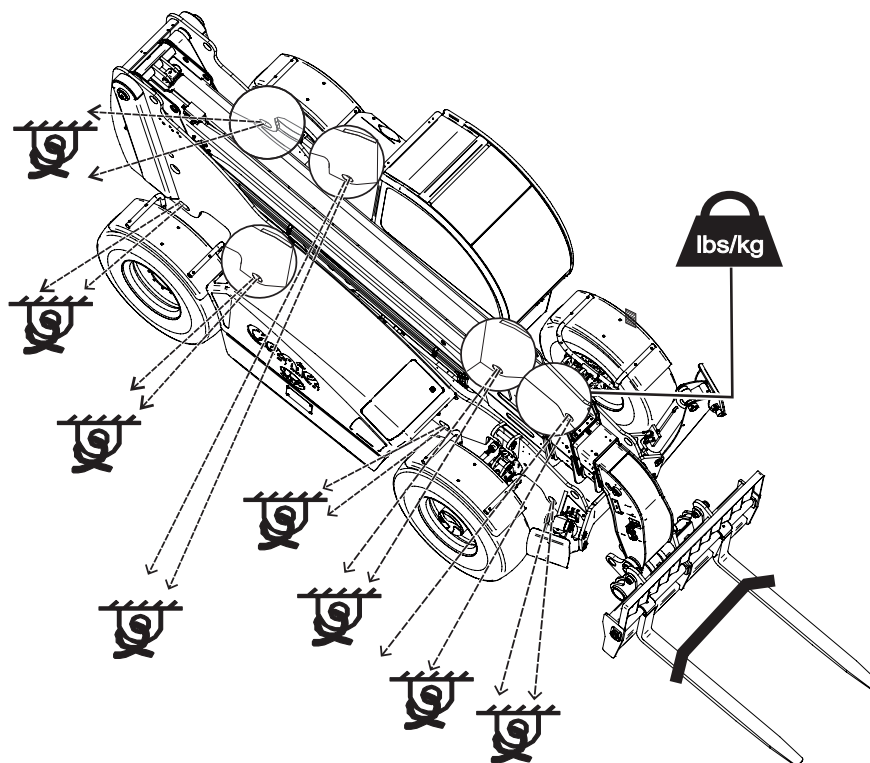

Attachments

▲ Suspended Load Hazards

Work Area Safety

General Safety

Do not lift a suspended load without first understanding the local, state, federal, or provincial rules, standards and regulations related to the activity. In the USA requirements are set forth in ANSI/ITSDF B56.6 and OSHA 29 CFR 1926.1400-1442. Additional rules, standard and regulations may apply. Additional training may be required.

If a telehandler must be used to transport a load, the following precautions for the protection of the operator shall be taken.

Read, understand and obey all warnings and instructions provided with the attachment that is approved for suspending loads.

Only a properly designed, tested and approved attachment should be used to carry a suspended load.

The telehandler load charts are designed for loads where the load center is stationary. As a suspended load moves, the load center can change. As a result, extreme caution in transporting and lifting, or placing, the load must be observed to minimize the potential for the load to move.

Overturning Hazards

Do not lift a suspended load without the proper and legible load capacity chart for the attachment/telehandler combination you are using.

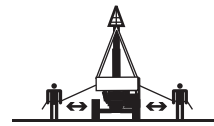

Do not permit the load to swing freely. Always properly tether loads to restrict movement. Driving across grades, sudden starts, stops, and turns can cause the load to swing and create a hazard if not externally stabilized.

Keep the boom retracted as much as practical.

Do not lift suspended loads when wind speeds can cause an unsafe situation.

All movements of the load must be accomplished gradually and at the slowest practical speed to prevent the load from swinging.

Keep the heavy part of the load closest to the attachment.

Never drag or pull a load sideways.

Only lift a load vertically; do not pull a load horizontally as it could cause excessive swinging of the load.

The weight of all rigging (slings, shackles etc.) must be included as part of the load.

CLICK HERE TO **DOWNLOAD** THE COMPLETE MANUAL

- Thank you very much for reading the preview of the manual.
- You can download the complete manual from: www.heydownloads.com by clicking the link below



- Please note: If there is no response to CLICKING the link, please download this PDF first and then click on it.

CLICK HERE TO **DOWNLOAD** THE COMPLETE MANUAL