

Manure Spreaders

Models 1177

1217

1287

1410

Form No.
907540
Revision D

GEHL® AGRICULTURE



OPERATOR'S MANUAL

CLICK HERE TO **DOWNLOAD** THE COMPLETE MANUAL

- Thank you very much for reading the preview of the manual.
- You can download the complete manual from: www.heydownloads.com by clicking the link below



- Please note: If there is no response to CLICKING the link, please download this PDF first and then click on it.

CLICK HERE TO **DOWNLOAD** THE COMPLETE MANUAL



SAFETY

(Continued)



NEVER use your hands to search for hydraulic fluid leaks. Use a piece of paper or cardboard. Escaping fluid under pressure can be invisible and penetrate the skin, causing a serious injury. If any fluid is injected into your skin, see a doctor at once. Injected fluid **MUST** be surgically removed by a doctor familiar with this type of injury or gangrene may result.

NEVER use too small of a tractor. A small tractor may be able to pull the unit, but the tractor would not be heavy enough for adequate traction and braking to control the weight of the heavy Spreader on hills and for steering. NEVER use smaller than the recommended size tractor.

To ensure continued safe operation, replace damaged or worn-out parts with genuine GEHL service parts, **BEFORE** attempting to operate this equipment.

Our Company does not sell replacement tires. In addition, tire mounting, service or inflation can be dangerous. Whenever possible, trained personnel should be called to service and/or mount tires, following the tire manufacturer's instruction. If you do not have such instructions, contact your tire dealer or our Company. In any event, to avoid possible fatal or serious injury, follow the specific directive given in the Service chapter of this manual.

BE SURE rotating shields on telescoping PTO driveline turn freely **BEFORE** starting tractor engine.

BE SURE the hitchjack locking pin is completely engaged and that the machine is properly blocked and prevented from rolling **BEFORE** disconnecting the unit from the tractor.

Block the Spreader so it will not roll after it is disconnected from the tractor.

To avoid injury, stay out of the Manure Spreader box. If entrance into the box is required, **BE SURE** to exercise the **MANDATORY SAFETY SHUTDOWN PROCEDURE** **BEFORE** going in.

MANURE GAS IS A DEADLY KILLER! Good safety practices dictate that you **NEVER** enter a manure pit alone. **BE SURE** someone else is around to help you out in an emergency. Also, **BE SURE** to wear a self-contained breathing apparatus, if you must enter a liquid manure pit.

REMEMBER, it is the owner's responsibility for communicating information on the safe use and proper maintenance of this machine.

Nutrient losses from manure can be minimized by incorporating surface applied manure within 72 hours. If manure remains on the soil surface, losses of nutrients may occur to the atmosphere or in runoff.

To determine nutrient credits for manure that has not been analyzed, establish the field manure history and use the table values (Tables 1 & 3). Multiply the manure application rate by the appropriate nutrient content (lbs. per ton or lbs. per 1000 gal.). In situations where the

nutrient content of manure has been analyzed, multiply the total nutrient content by the appropriate percent available nutrient value (Table 2) by the application rate.

In summary, using the table information/data in conjunction with soil testing, an application rate can be determined that will fit your nutrient management plan. Assistance may be obtained from your local University Extension office.

Table 2. First year availability estimates for N, P₂O₅, and K₂O for analyzed manure.

Animal Type	First year availability		
	N	P ₂ O ₅	K ₂ O
		Percent available nutrients	
Dairy	30(35) ¹	55	75
Beef	25(30)	55	75
Poultry	50(60)	55	75
Swine	40(50)	55	75

¹Nutrient values in parenthesis are for manure incorporated within 3 days of application.
Source: USDA-NRCS Wisconsin Field Office Tech. Guide, Sec. IV-Spec. 590

Table 3. Estimates of Available Nutrients from Liquid Manure by Species and Management Systems for up to Three or More Consecutive Years of Application

Species/Management	Total Available Nutrients lbs./1,000 gallons			
	N		P ₂ O ₅	K ₂ O
	Surface Applied	Incorporated by 3rd Day		
One Year of Application				
Dairy	7	10	5	16
Beef	5	7	5	16
Swine indoor pit	25	33	25	24
Swine outdoor pit	17	22	10	16
Swine farrow nursery indoor pit	13	16	14	18
Poultry	8	10	6	10
Two Consecutive Years of Application				
Dairy	10	12	6	18
Beef	7	9	6	18
Swine indoor pit	30	38	29	27
Swine outdoor pit	20	26	11	18
Swine farrow nursery indoor pit	15	19	16	20
Poultry	10	11	7	11
Three or More Consecutive Years of Application				
Dairy	11	13	7	19
Beef	8	10	7	19
Swine indoor pit	33	40	32	29
Swine outdoor pit	22	27	12	19
Swine farrow nursery indoor pit	16	20	17	21
Poultry	10	12	8	11

Table derived from Midwest University Extension Publications.
Figures are rounded to the nearest whole pound.

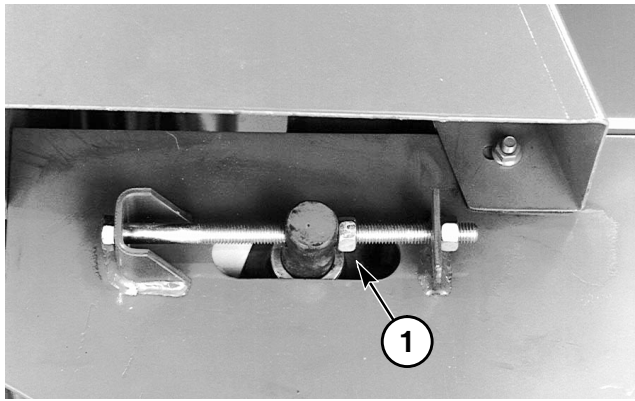

1 - Outer chain adjustment nut
Fig. 18

APRON DRIVE SHEAR BOLT (Fig. 19)

The apron drive is protected by a shear bolt. Refer to the individual model parts book for the proper shear bolt used in each model Spreader. Shearing of the bolt is usually due to the apron being frozen to the floor, or the slats catching on manure frozen to the floor.

An extra shear bolt is carried in the support as shown.

In some cases, the bolts will shear due to the Spreader being overloaded. If the bolt shears, the drive hub can be rotated counterclockwise until the bolt holes align. Always determine the cause of the failure, and eliminate it before installing the new bolt. Use a genuine GEHL shear bolt.

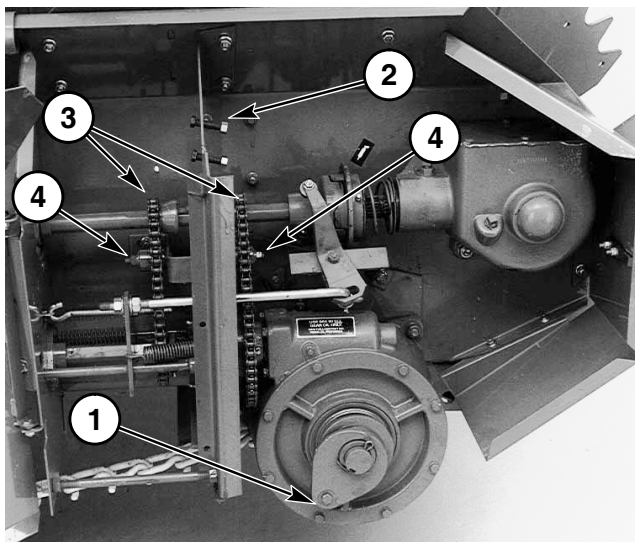

1 - Apron drive shear bolt
2 - Extra shear bolt storage
3 - Drive chains
4 - Idler blocks

Fig. 19

GEARBOX DRIVE CHAINS (Fig. 19)

Adjust the gearbox drive chains to deflect 1/4" to 3/8" (6.4 mm to 9.5 mm) with 5 lbs. (22 N) force at the mid-span of the chain. Adjust the chains by moving the idler blocks. **DO NOT OVERTIGHTEN THE CHAINS.**



Before tightening the worm gearbox drive chain, do the following:

1. Place the rotary quadrant in slow position.
2. Rotate the Spreader drive shaft in the direction of operation at least five revolutions.
3. Tension the worm gearbox drive chains.

FEED CONTROL (Figs. 20 - 22) (Mechanical Drive Only)

Check the feed control system at the beginning of each season and adjust, if necessary, to compensate for wear. Be sure the control linkage always works freely.

Adjust the unloading speed linkage using the following steps:

1. Set the apron speed control quadrant in  or slow position.
2. Rotate the drive shaft by hand until the clutch teeth and slow speed sprocket teeth engage as shown in Figure 20.
3. Adjust eyebolt, Figure 20, until the driving teeth of the shifting clutch are engaged fully with the teeth on the slow speed sprocket. Proper engagement is when both clutch and slow speed sprocket are flush to 1/16" (1.6 mm) extended from the sprocket tooth.
4. Move the feed control quadrant to the  position or fast apron speed. In this position the sliding clutch half should be fully seated in the front (high speed) sprocket, Figure 21.
5. Adjust the control rod, Figure 21, so the rollers just clear the beater clutch hub.
6. Move the feed control lever to "C", cleanout position (beater not operating). There should be 1/8" (3.2 mm) clearance between the beater clutch teeth. Adjust the length of the control rod, Figure 21, to obtain 1/8" to 3/16" (3.2 mm to 4.8 mm) clearance between the clutch jaws as shown in Figure 22.

Notes

Locate the PTO shaft bearing housing to the front side of the bearing support and install 3/8" x 1" (9.5 mm x 25 mm) cap screws and flange nuts as shown in Figure 38, to retain the PTO shaft bearing housing. Place the drive belt on the pulley as shown and attach the shaft support to the main frame with two 3/8" x 1" (9.5 mm x 25 mm) cap screws and flange nuts.

Install a square key in the propeller shaft and install driven sheave, Figure 39. Use a straightedge to align it with the drive sheave. Secure the driven sheave to the propeller shaft with two 3/8" x 3/4" (9.5 mm x 19 mm) set screws and jam nuts.

Install idler J-bolt, Figure 39, through the frame and the belt tension idler bracket. Install the spring tension gauge, spring, 3/8" (9.5 mm) flat washer, and two 3/8" (9.5 mm) nuts. Tighten the nuts until the spring is compressed to the length of the spring gauge. Check the alignment of the idler pulley and shim if necessary.

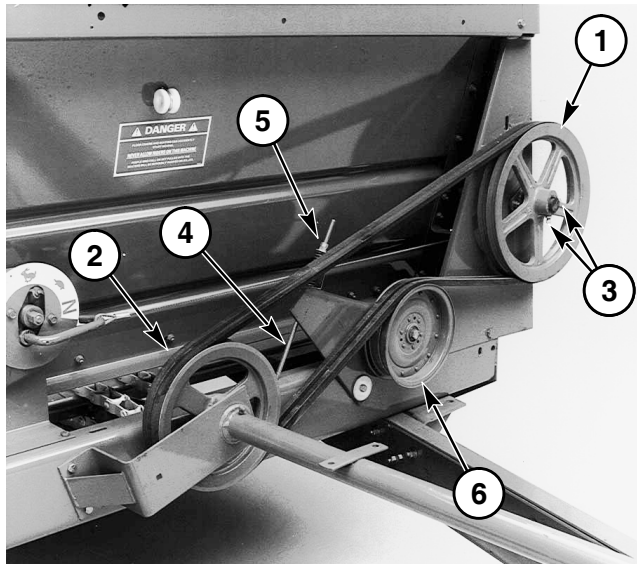

- 1 - Driven sheave 15" (381 mm)
- 2 - Drive sheave 11" (279 mm)
- 3 - 3/8" x 3/4" (9.5 mm x 19 mm) set screws and jam nuts
- 4 - Idler J-bolt
- 5 - Spring tension gauge, spring, flat washer and nuts
- 6 - Idler pulley

Fig. 39: 1000 RPM PTO Configuration

NOTE: The drive shaft has been assembled with the 11" (279 mm) drive sheave for 1000 RPM PTO tractors. If the Spreader is to be assembled for 540 RPM, the following procedure to convert it must be used.

1. Remove the drive shaft from the Spreader.

2. Remove the cotter key, slotted nut, and washer securing the drive sheave to the rear of the drive shaft.
3. Install the large 15" (381 mm) sheave on the rear of the drive shaft. Install the flat washer and castellated nut. Tighten securely. Then back off the nut to the nearest set of castellations and install the cotter key.
4. Install the 11" (279 mm) sheave on the propeller shaft as shown. Align with the drive sheave and secure with two 3/8" x 3/4" (9.5 mm x 19 mm) set screws and jam nuts, Figure 40.
5. Reinstall the drive belts. Tighten the nuts on the belt idler J-bolt, until the spring is compressed to the length of the spring gauge.

NOTE: If the Spreader is changed for 540 PTO operation, obtain a 143048 front PTO assembly from the Gehl Parts Department.

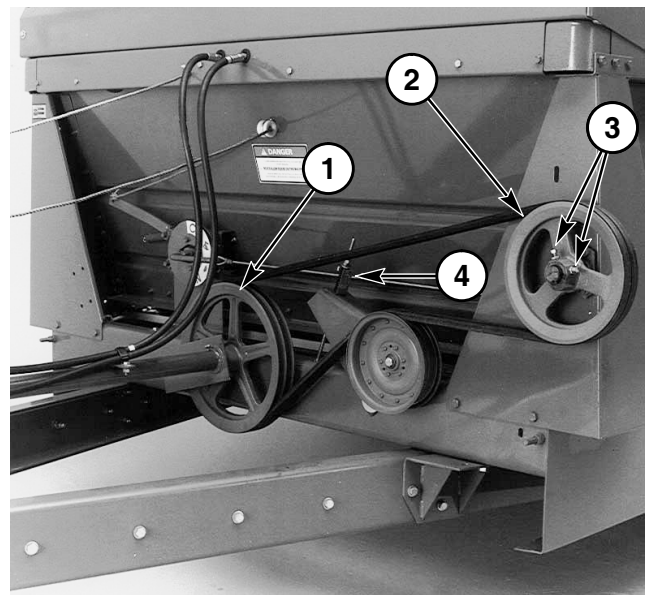

- 1 - 15" (381 mm) sheave
- 2 - 11" (279 mm) sheave
- 3 - 3/8" x 3/4" (9.5 mm x 19 mm) set screws and jam nuts
- 4 - Idler J-bolt

Fig. 40: 540 RPM PTO Configuration

ROPE

Thread one end of the control rope through the porcelain rope guide and through the hole in the control lever as shown in Figure 40. Tie a knot at the end of the rope.

CLICK HERE TO **DOWNLOAD** THE COMPLETE MANUAL

- Thank you very much for reading the preview of the manual.
- You can download the complete manual from: www.heydownloads.com by clicking the link below



- Please note: If there is no response to CLICKING the link, please download this PDF first and then click on it.

CLICK HERE TO **DOWNLOAD** THE COMPLETE MANUAL