

# Loader Wagon

**Tigo 65 XR**

**Tigo 65 XR D**

**Tigo 75 XR**

**Tigo 75 XR D**

**Tigo 90 XR**

**Tigo 90 XR D**

**Tigo 100 XR**

**Tigo 100 XR D**



CLICK HERE TO **DOWNLOAD** THE COMPLETE MANUAL

- Thank you very much for reading the preview of the manual.
- You can download the complete manual from: [www.heydownloads.com](http://www.heydownloads.com) by clicking the link below



- Please note: If there is no response to CLICKING the link, please download this PDF first and then click on it.

CLICK HERE TO **DOWNLOAD** THE COMPLETE MANUAL

- The PTO shaft must not be used with a missing or damaged guard. You must always use the correct restraining system
- Only use manufacturer approved replacement parts when you replace any part of the PTO shaft
- Do not stand on the PTO or the PTO drive shaft
- Always attach the restraining chain to the PTO
- Do not remove a blockage by hand or by foot. Always use an applicable tool
- Make sure that you set the pressure of the tyres of the transport wheels to the pressure specified. Do not put less than or more than the specified pressures in the tyres
- We recommend to only replace the first tyres with tyres that have speed category and load specifications the same or better than the values in the tyre pressure table. If you do not do this, it can cause dangerous problems.

---

### 1.2.2 Safe Driving

---

Read and understand the general safety instructions. Make sure that:

- You always obey your local road traffic regulations and the speed limits
- The drawbar and the parking jack are in the drive position
- The machine is in the transport position
- The tailgate is not open and locked
- The trailed steering axle (if present) is locked
- All parts that move (for example the folding components and covers) are locked
- If the machine has a dual line brake system, and hydraulic brake away before you move the machine:
  - Couple and connect the lines
  - Press and hold the brake pedal for 10 seconds
- The tractor hydraulic system is OFF
- All the lamps on the machine operate correctly and are clean from dirt
- Examine the operation of the brakes before you start to drive. Do not drive with the machine if there is a problem with the brakes
- Do not make sudden turns when on a slope
- Drive slower when on a down slope
- Do not disengage the clutch of the tractor or change gears on a slope.

---

### 1.2.3 Public Road Transport Safety

---

Read and understand the general safety instructions before you drive on the road. When you drive on the road:

- Obey the local road traffic laws
- Keep a safe distance from other traffic
- Make sure that the plug for the lighting cable fully connects to the tractor socket and the lamps operate correctly
- If you have a work lamp on the machine, make sure that you set it off before you drive on the road
- Use warning lamps or other safety signs, if necessary
- If necessary by local law install the rear marking plate for Slow Moving Vehicles (SMV) on to the machine
- If necessary by local law install the licence plate on the machine
- If necessary by local law, install the safety chains. Connect them to a rigid part of the tractor
- If there is a hydraulic brake system, always connect the safety brake cord (optional)
- Remove loose objects that can fall off the machine, for example, loose crops, mud or soil
- Make sure that only approved tyre types are in use on the machine. Tyres not approved by the manufacturer can be dangerous. Examine the transport wheels nuts and tighten them if necessary after the set working hours or driven distance. Make sure that the tyres have the correct pressure. Do not inflate the tyres with more than the recommended quantity of air
- Do not operate hydraulic components

## **2.1 Preface**

### **2.1.1 Manual Contents**

---

This manual contains the technical information, operating instructions, maintenance procedures and the troubleshooting information necessary to operate the machine.

The information in this manual is for the operator.

Make sure that you fully understand all the information before you operate the machine. If you do not, personal injury or damage to the equipment can occur.

Speak to your local approved dealer if you do not understand the information in this manual, or if more information is necessary.

All the information in this manual has been collected carefully. The manufacturer will not be liable for errors or faults in this manual.

All areas of information in this manual are recommendations on the economical use and safe operation of this machine.

All the information used to assemble the instructions, illustrations and specifications was correct at the time of writing this manual.

Your machine can have equipment and optional components not shown in this manual.

All information in this manual has been collected carefully. But, the manufacturer cannot guarantee that the manual is free of errors in all languages.

#### **Standard Torque Loading of Parts**

Tighten all the nuts, bolts and screws used on the machine to the standard torque applicable to the materials used in assembly.

If a component does not have a standard torque value, the correct value is specified in the applicable section of the manual.

Although the machine is a Loader Wagon and a Silage Transport Wagon, the term used in the manual is 'machine'.

### **2.1.2 Vehicle Identification Number (VIN) and VIN Plate**

---

You must give the local approved dealer the type and serial number(s) of the machine when you order parts or schedule maintenance.

The Vehicle Identification Number (VIN) and VIN Plate attaches to the body behind the safety guard, on the front right of the machine. A serial number mark can also be found on the chassis at the front of the machine.

- (3) Hydraulic cylinder to operate the main shaft clutch (only D model)
- (4) Machine tool
- (5) Main shaft gearbox (connects to the PTO shaft)

The main clutch operates the pick-up unit and the cutting unit. The main clutch has these functions:

- Disengage the pick-up unit and the cutting unit when there is a blockage. If necessary, to turn the main shaft in the opposite direction with the machine tool. You can disengage the main clutch manually with a lever
- Disengage the pick-up unit and the cutting unit when you release a load while the PTO drives the discharge unit (optional). With the discharge unit a hydraulic cylinder connects to the hydraulic system of the tailgate. This hydraulic cylinder operates the main clutch. The main clutch disengages when the tailgate opens.

The discharge unit (optional) connects to the main shaft through the front gearbox of the discharge unit (see chapter 2.3.12 *Discharge Unit (optional)*, page 35 ).

## 2.3.7 Hydraulic System

If the chassis has no automatic suspension, the tractor must have one of these types of hydraulic system:

- Fixed displacement system (the hydraulic pump of the tractor is continuously on and a valve causes the unwanted pressure to recycle)
- Load sensing system (the pump capacity is controlled to deliver pressure and flow when necessary)
- Closed centre system (the pump is continuously on, but there is no recycled flow if pressure and flow are not necessary).

If the chassis has automatic suspension, the tractor must have a load sensing hydraulic system.

The solenoid valves in the hydraulic manifold control the hydraulic cylinders and hydraulic motors.

- (1) Hydraulic manifold with solenoid valves
- (2) Filter of the hydraulic system

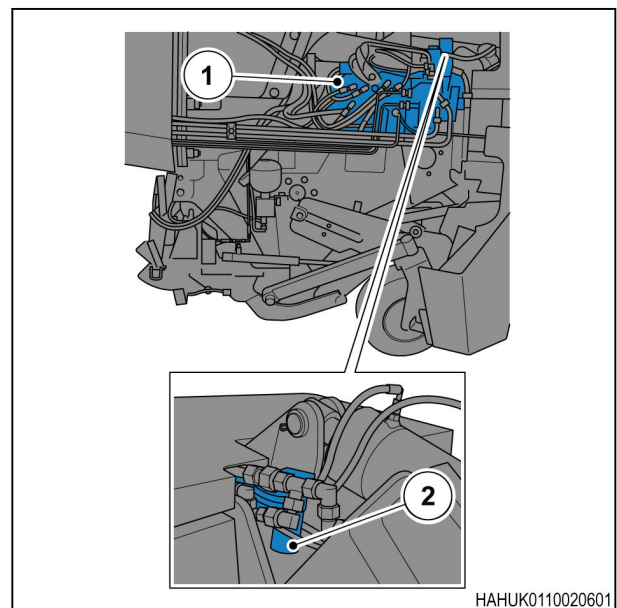
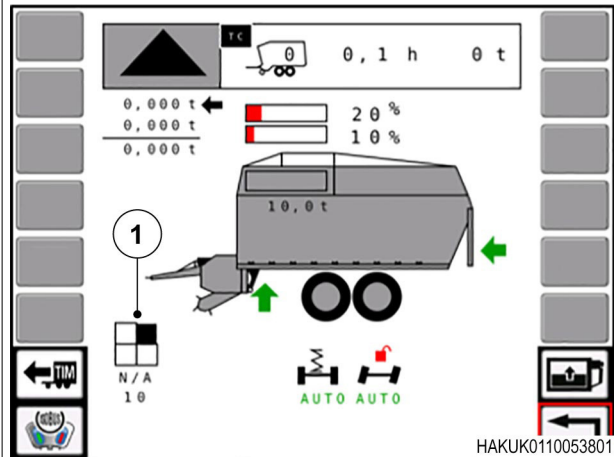

Fig. 15

## Automatic mode status

### Automatic mode not available (1):

TIM client (Tigo) is connected - automatic mode not available/cannot be operated.



### Automatic mode ready to enable (2):

All conditions are correct.

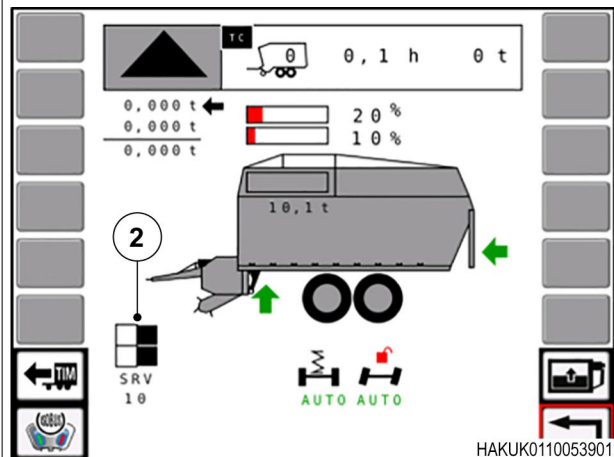

### Automatic mode enabled (3):

On the client (Tigo) the switch is set to ON.

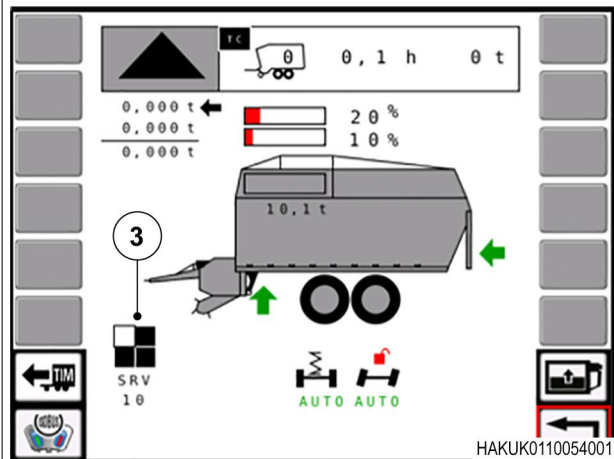





## 2.5.6 Group 6: Set Functions

The set functions in the ISOBUS control panel let you adjust some of the functions on the machine, the:

- Start angle of the front bulkhead (1)
- Drawbar load position (2)
- Drawbar transport position (3)
- Chassis height (4)
- Pick-up angle (5)
- Pick-up speed (6) (hydraulic driven pick-up only).

Set the ISOBUS control panel to the set functions mode:

1. Press  to set the ISOBUS control panel to off.
2. Press and hold  and then press  to set the ISOBUS control panel to on. The button for the set function flashes.
3. Press  to set the next function.
  - The button for the set function ((1) to (6)) flashes.
  - The value for the function shows on the LED screen.

All the functions have a pair of buttons that increase or decrease the function value.

Some of the functions have a mode that you can set to on or off. When the LED (7) is on, the mode is set to on. When the LED (7) is off, the mode is

set to off. Press  to change the mode to on or off.

Press  to save your changes (this also sets the ISOBUS control panel to off).

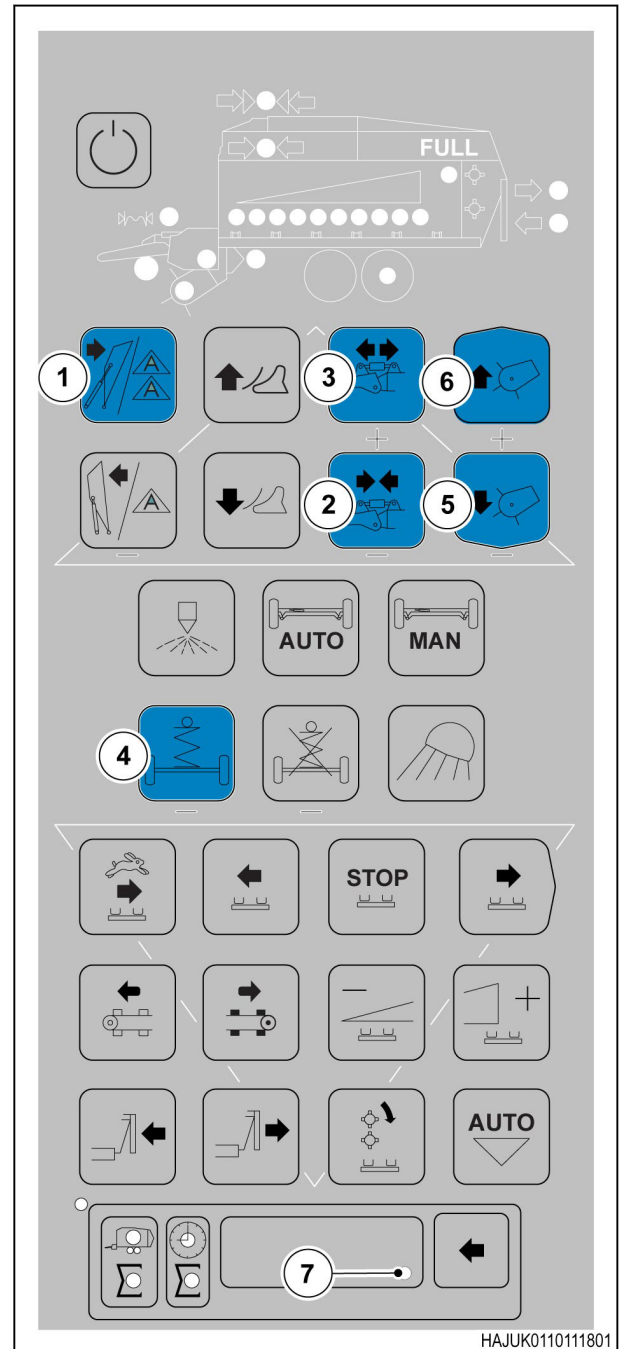

Fig. 35

## 2.6.1 Main Menu

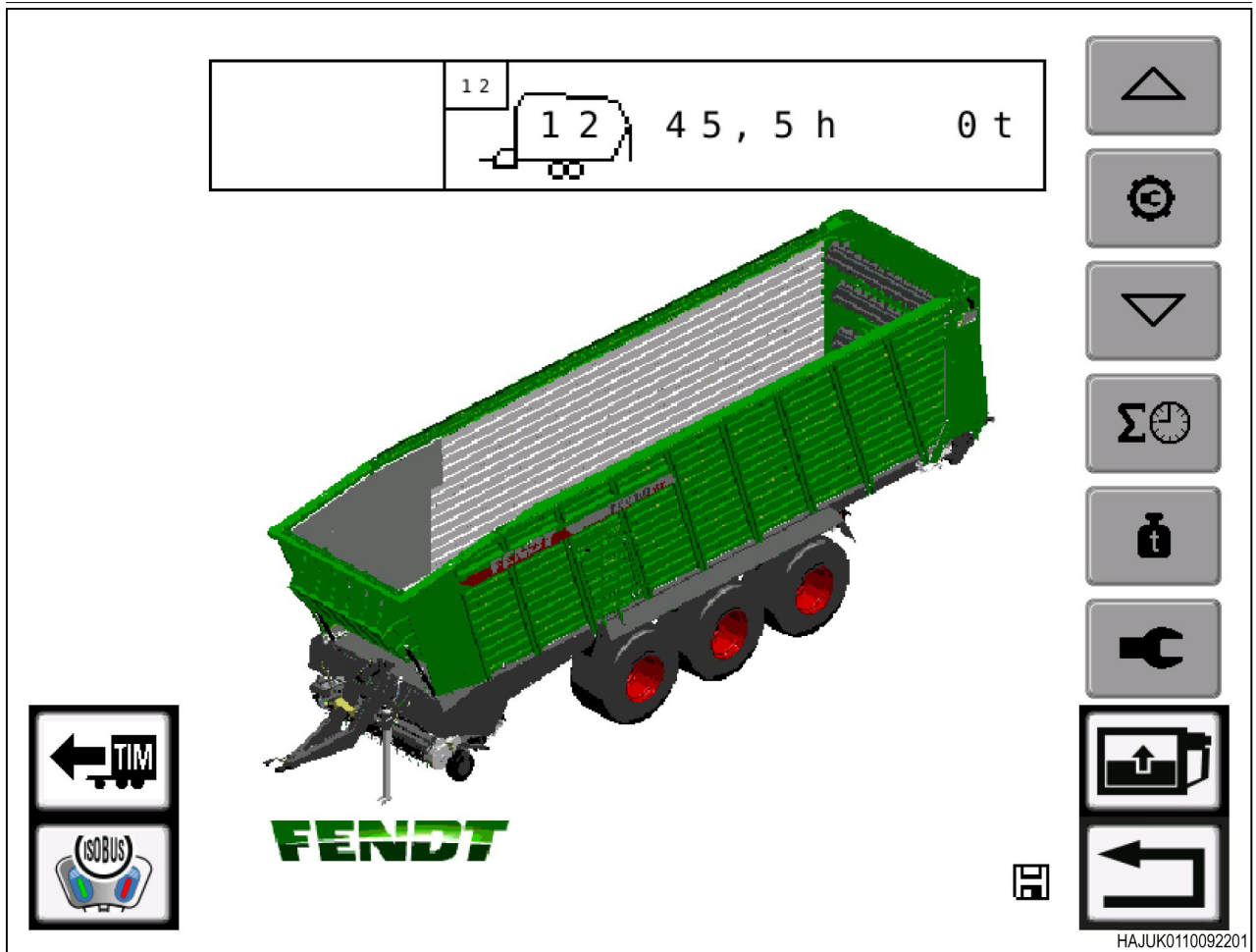





Fig. 47

Button	Function
	Fill a load menu
	General settings menu
	Release a load menu
	Counter menu
	Weighing menu
	Maintenance menu

Button	Function
	Calibrate with a full machine
	Calibrate with an empty machine
	Accept the calibration values
ESC	Discard the calibration values

## 2.6.8 Maintenance Menu

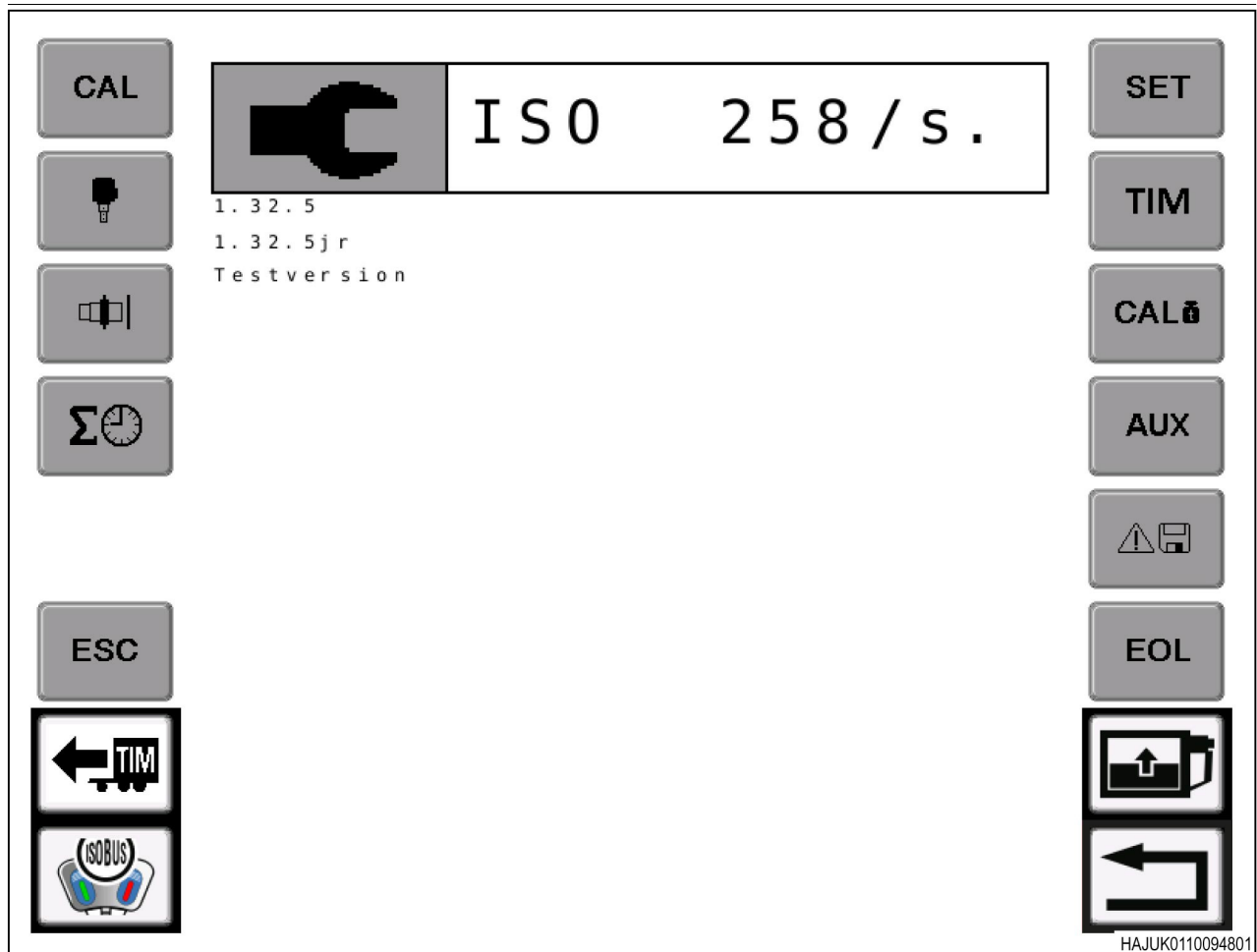

Fig. 54

Button	Function
ESC	Go to the main menu
CAL	Go to the weigh system calibration menu
EOL	Go to the end of line menu Only for approved technicians.
CAL	Go to the calibration menu

## 3 Operation

<b>3.1</b>	<b>First Use</b> .....	<b>83</b>
3.1.1	Prepare for the First Use .....	83
3.1.2	Assembly by the Dealer .....	83
3.1.3	Remove the blockage of the hydraulic system for the forced steering axle .....	83
3.1.4	Adjust the Automatic Load-Sensitive Brake System (pneumatic brakes) .....	84
3.1.5	Adjust the Load Sensing System .....	84
3.1.6	Adjust the Height of the Hydraulic Drawbar .....	85
3.1.7	Align the Forced Steering System .....	86
3.1.8	Install the PTO Overload Protection .....	87
3.1.9	Adjust the Length of the PTO Shaft .....	88
3.1.10	Connect a Preservative Application System (optional) .....	89
3.1.11	Connect the Tractor implement management (TIM) for the first time (option) .....	90
<b>3.2</b>	<b>Connect the Machine to the Tractor</b> .....	<b>97</b>
3.2.1	Connect the Lighting Cable .....	97
3.2.2	Connect the User Interface(s) .....	97
3.2.3	Connect to the ISOBUS Control Panel .....	98
3.2.4	Connect to the ISOBUS Socket .....	98
3.2.5	Connect the Hydraulic and Pneumatic Hoses .....	98
3.2.6	Connect the Drawbar Coupling .....	100
3.2.7	Connect the Forced Steering System (optional) .....	101
3.2.8	Connect the Hydraulic Break-Away System (optional) .....	102
3.2.9	Connect the Power Take Off (PTO) Shaft .....	102
<b>3.3</b>	<b>Transport Position and Driving</b> .....	<b>103</b>
3.3.1	Put the Parking Jack in the Driving Position .....	103
3.3.2	Drain the Air Container of the Pneumatic Brake System (optional) .....	104
<b>3.4</b>	<b>Prepare the Machine for a Load</b> .....	<b>106</b>
3.4.1	Install the Intake Duct Cover Plate (optional) for Loading with a Forage Harvester .....	106
3.4.2	Adjust the Working Height of the Pick-up .....	106
3.4.3	Adjust the Height of the Touch Roller (optional) .....	107
3.4.4	Adjust the Height of the Wind Guard .....	108
3.4.5	Adjust the Pressure on the Hydraulic Pick-up Suspension (optional) .....	109
3.4.6	Adjust the Distance Between the Knives and the Rotor .....	109
3.4.7	Select the Number of Knives .....	111
3.4.8	Set the Crop Compression .....	111
3.4.9	Set the Crop Compression Value on the ISOBUS control panel .....	111
3.4.10	Set the Crop Compression Value on the ISOBUS Terminal .....	112
3.4.11	Set and Start a Job Counter on the ISOBUS control panel .....	112
3.4.12	Select and Start a Counter on the ISOBUS Terminal .....	113
3.4.13	Configure the TIM and set the target speed .....	113
<b>3.5</b>	<b>Fill the machine</b> .....	<b>115</b>
3.5.1	Fill the Machine Automatically .....	115
3.5.2	Fill the Machine Manually .....	117
<b>3.6</b>	<b>Weigh the load (with optional weigh system)</b> .....	<b>120</b>
3.6.1	Weigh Manually .....	120
<b>3.7</b>	<b>Empty the Machine</b> .....	<b>121</b>
3.7.1	Empty the Machine Automatically .....	121
3.7.2	Empty the Machine Manually .....	123
<b>3.8</b>	<b>Disconnect the Machine From the Tractor</b> .....	<b>125</b>
3.8.1	Put the Parking Jack in the Park Position .....	125



Function assigned to Server .





Client set point: request value for vehicle speed.



Operator limit:



- : Current vehicle speed is set as  → Client can't accelerate above.



Cruise control LIMIT ( $\triangleq$  C1), see chapter "Engine & Transmission"

- Activating C1 ( $\triangleq$  LIMIT) sets 
- Value stored for reusing after power cycle or reenabling Server .



Cruise control C2, see chapter "Engine & Transmission"

### Procedure

1. Connect implement to vehicle, see "Add ISOBUS implement".

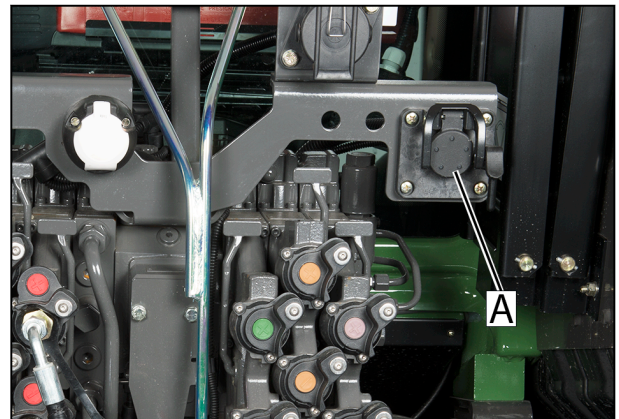

Fig. 14



Result

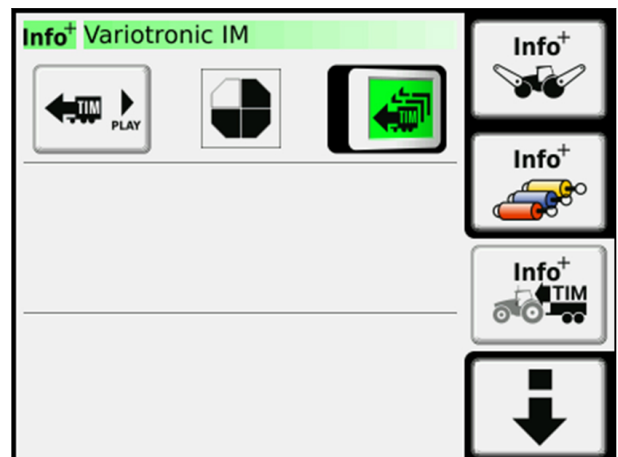

Fig. 15

CLICK HERE TO **DOWNLOAD** THE COMPLETE MANUAL



- Thank you very much for reading the preview of the manual.
- You can download the complete manual from: [www.heydownloads.com](http://www.heydownloads.com) by clicking the link below



- Please note: If there is no response to CLICKING the link, please download this PDF first and then click on it.

CLICK HERE TO **DOWNLOAD** THE COMPLETE MANUAL

## Procedure

1. Lift the drawbar higher than the tractor's ball head or pin. Press  (ISOBUS control panel) or  (ISOBUS terminal).
2. Carefully drive the tractor in reverse to put its ball head or pin below the machine's drawbar connection.
3. Lower the drawbar. Press  (ISOBUS control panel) or (ISOBUS terminal).
4. Lock the connection. Refer to the tractor's operators manual for more information.

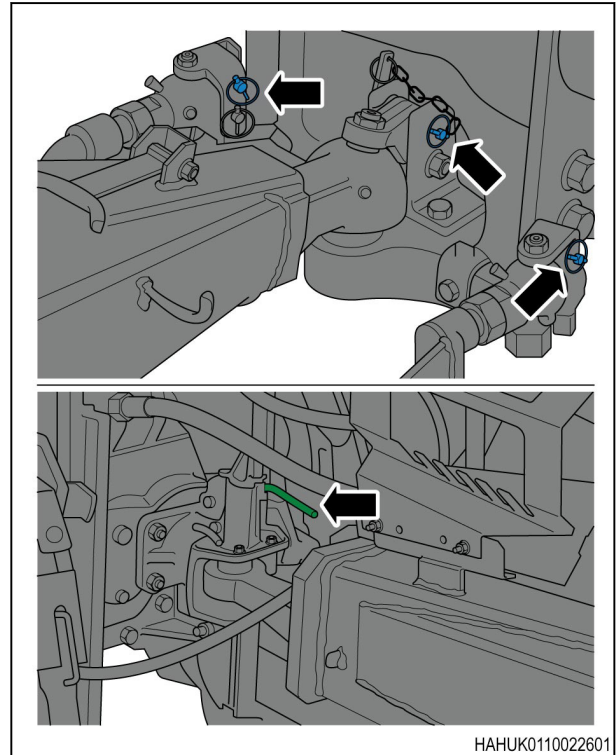

Fig. 26

### After finishing the procedure



#### CAUTION: Blockage

Before you drive the tractor: Put the parking jack in the driving position. Disengage the parking brake. Remove the wheel wedges.

## 3.2.7 Connect the Forced Steering System (optional)

### Before starting the procedure

This procedure is only applicable to machines with forced steering.

Connect the machine to the tractor and park in a straight line.

### Procedure

1. Connect the forced steering systems K50 ball head couplers to the tractor.
2. Lock the couplers (see chapter 3.2.6 [Connect the Drawbar Coupling](#), page 100 ). Refer to the tractor's operators manual for more information.
3. Examine the forced steering system pressure gauges. The pressure must be 90 - 110 bar (1305 - 1595 psi). If the pressure is not in this range align the forced steering system.

### 3.4.7 Select the Number of Knives

**NOTE:** For this procedure, the machine tool is necessary. You find this tool in a holder at the rear of the left safety guard of the pick-up/cutting unit.

The knife assembly has 2 knife groups. You can move one of these groups out of and into the feeder to set the cutting length to 74 / 37 mm (2.91/1.46 in.):

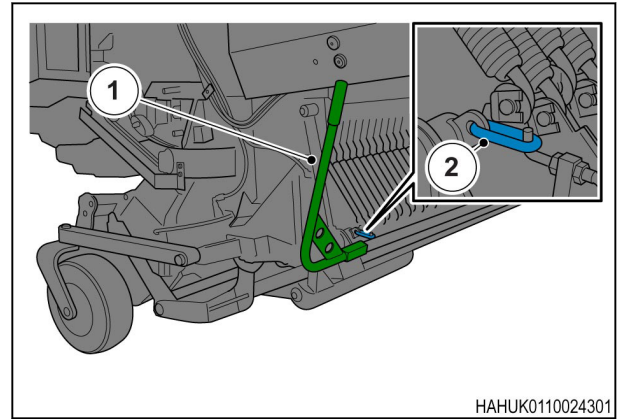

Fig. 39

### 3.4.8 Set the Crop Compression

#### Before starting the procedure

When you fill the machine automatically you can set low compression or high compression of the crop. You can adjust the compression value. Set the crop compression to 10 - 15% for a moist crop. Set the crop compression to 15 - 25% for a dry crop.

### 3.4.9 Set the Crop Compression Value on the ISOBUS control panel

#### Procedure

1. Press and at the same time.
2. Press to for the low compression value or press for the high compression value. The two left digits on the display show the crop compression value (%).
3. Press to increase the value or to decrease the value on the display.
4. Press and at the same time to save the value.
5. Press two times to use the low compression value you added. Press two times to use the high compression value you added.

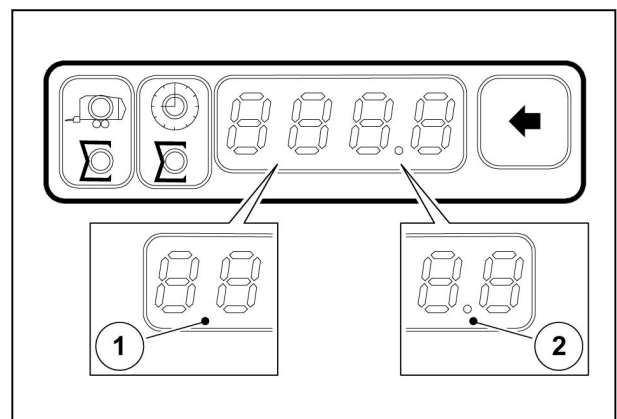

Fig. 40 Display on the ISOBUS control panel

- 1 Set compression value
- 2 Measured compression value

## 3.7 Empty the Machine



**DANGER: Danger**

**Personal injury**

**Make sure that there are no persons in the area (20 m or less from the tractor and machine) when you operate the tailgate, floor conveyor and when you engage the PTO.**

For a D model make sure that the primary drive clutch lever is unlocked, to let the hydraulic cylinder operate the main drive clutch. (see chapter 2.3.6 *Main Drive*, page 30 ) The figure shown here is not of a XR (D), but is almost the same.

- A Main drive clutch locked in disengaged position
- B Lever unlocked

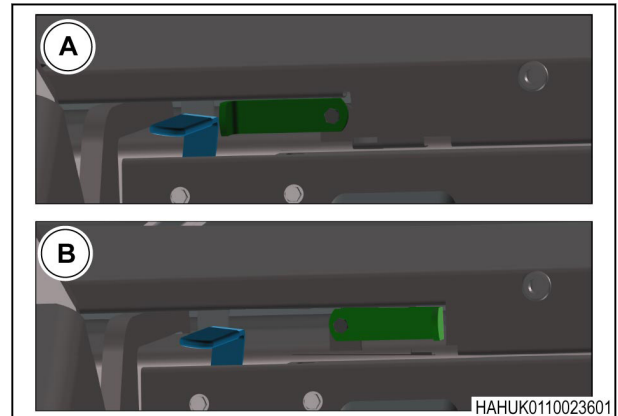

Fig. 49





Use one of these possible selections to empty the machine:

- Empty the machine automatically see chapter 3.7.1 *Empty the Machine Automatically*, page 121 .
- Empty the manually see chapter 3.7.2 *Empty the Machine Manually*, page 123 .

### 3.7.1 Empty the Machine Automatically

You can empty the machine automatically with the ISOBUS terminal or the ISOBUS control panel.

#### Procedure

1. Prepare the machine.
  - a) Press  on the ISOBUS terminal or the ISOBUS control panel to set it to on.
  - b) Press  to lock the steering axle (optional).
  - c) Press and hold  (ISOBUS terminal) or  (ISOBUS control panel) to lift the front of the machine.
2. Start the procedure.
  - a) Press and hold  for 2 seconds.
  - b) If the machine has a discharge unit (optional), engage the PTO and increase the speed to 1000 rpm.

#### Result

The:

1. Tailgate opens.
2. Clutch for the discharge unit (optional) engages.
3. Floor conveyor moves rearward.

## 4.1 Maintenance After the First Operation

### Procedure

1. Tighten the wheel nuts (see chapter 6.5 [Table of Standard Wheel Nut Torques](#), page 208 ).
2. Tighten the axle assemblies (see chapter 4.12.12 [Tighten the Axle Assemblies \(bogie suspension\)](#), page 163 ) if the machine has bogie suspension.
3. Tighten the spring mounting brackets (see chapter 4.12.13 [Tighten the Spring Mounting Brackets \(bogie suspension\)](#), page 163 ) if the machine has Hydropneumatic suspension.
4. Examine and tighten the spring bolts (see chapter 4.12.14 [Examine and Tighten the Spring Bolts \(hydropneumatic suspension\)](#), page 163 ).
5. Apply grease to the pivot points of the chassis (see chapter 4.12.2 [Apply Grease to the Pivot Points of the Chassis \(bogie suspension\)](#), page 157 ).

6. Remove the wheel nuts.

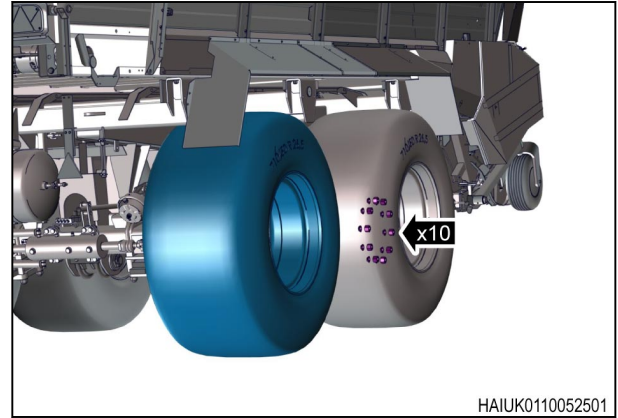

HAIUK0110052501

Fig. 4

7. Remove the wheel.
8. Install the replacement wheel and tyre on the hub.



**CAUTION: Risk of damage**

**Do not cause damage to the wheel studs when you install the wheel.**

9. Install the wheel nuts.
10. Tighten the wheel nuts by hand.
11. Lower the machine to the ground (with the jack).
12. Tighten the wheel nuts.
13. Adjust the tyre pressure.
14. If necessary release the manual steering axle lock.
15. Remove the wheel chocks from below the opposite wheel.
16. Release the parking brake.
17. Tighten the wheel nuts to the correct torque.

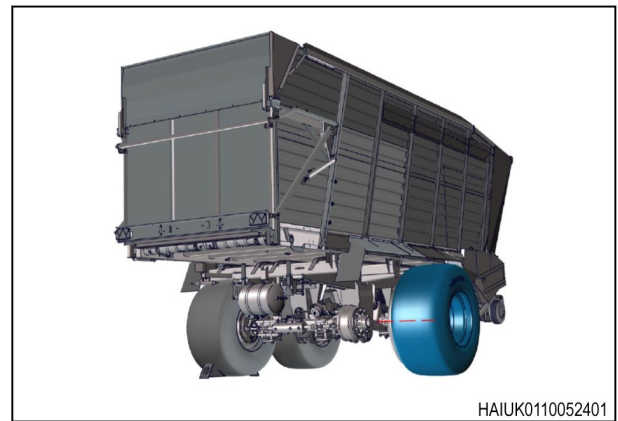

HAIUK0110052401

Fig. 5



**CAUTION: Risk of damage**

**Make sure that you tighten the wheel nuts again after the first 10 km of travel.**

## 4.10 Maintenance on the Floor Conveyor

### 4.10.1 Adjust the Tension in the Chains of the Floor Conveyor

#### Before starting the procedure

The machine has four floor conveyor chains

For each chain:

#### Procedure

1. Loosen the locknut (1).
2. With the adjustment bolt (2), adjust the tension in the chain until the play (A) is approximately 6 cm (2.4 in).
3. Tighten the locknut (1).

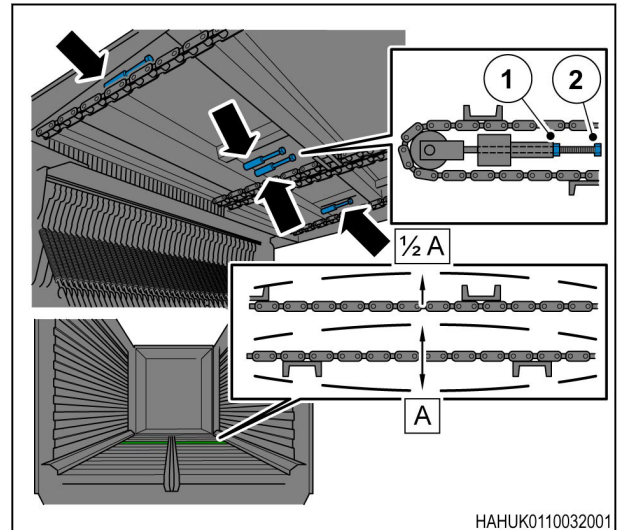

HAHUK0110032001

Fig. 21 Tensioners of the chains of the floor conveyor

### 4.10.2 Apply Grease to the Drive Shaft Bearings of the Floor Conveyor

#### Procedure

Apply grease to the drive shaft bearings through the grease nipples. Use a grease gun with NLGI class 2 grease.

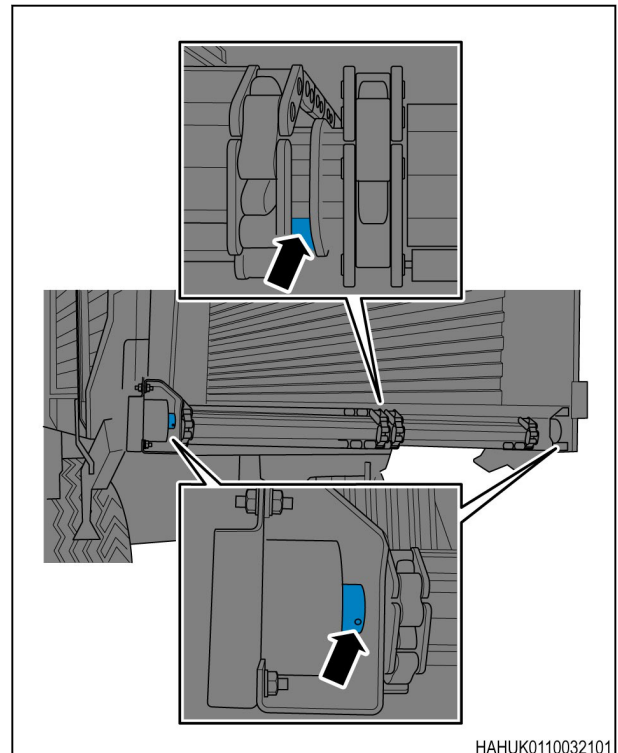

HAHUK0110032101

Fig. 22



**CAUTION: Damage to the machine can occur**

**Do not let grease contamination of the brake lining and brake shoes occur.**

**NOTE:** If you remove all the wheels together, make sure that you install each wheel in the same initial position.

**Procedure**

1. Lift up and make sure that the machine is safe.
2. Disengage the brakes.
3. For each wheel:
  - a) Remove the wheel nuts and remove the wheel from the hub
  - b) Remove the hub cap
  - c) Remove the split pin
  - d) Remove the axle nut
  - e) Remove the wheel hub with the brake drum, the taper roller bearings and the seals from the axle stub
  - f) Clean the brake mechanism and examine it. If necessary, replace worn parts
  - g) Clean the wheel hubs on the inner and outer faces. Remove all remaining grease
  - h) Clean the bearings and the seals and examine them. If necessary, replace them
  - i) Apply a small quantity of grease to the bearing seats
  - j) Apply grease to the bearings and put grease in the hub cap.

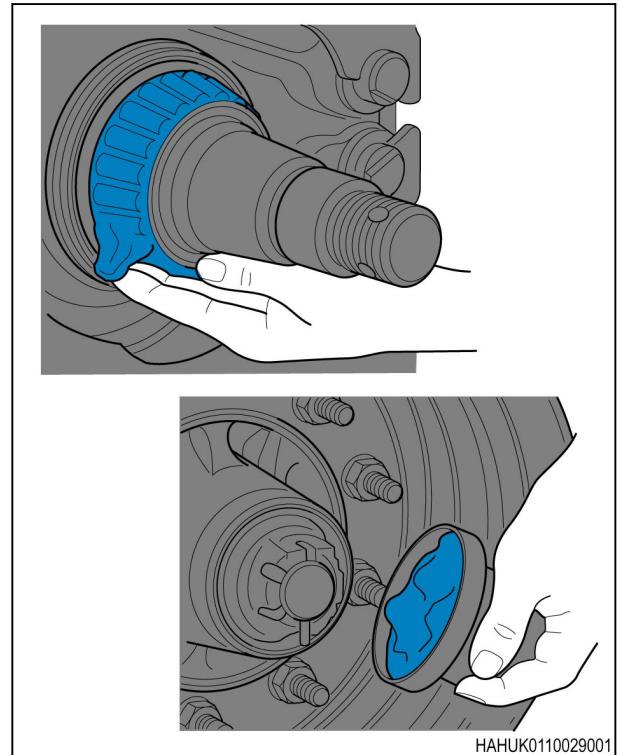



Fig. 40 Apply grease to the wheel hub bearings



Axle Type	Quantity of Grease (g)	
	Inner Side (A)	Inner Side (B)
<b>GS 5506</b>	<b>40</b>	<b>80</b>
<b>GS 7006</b> <b>GS7008</b>	<b>50</b>	<b>210</b>
<b>GS 8008-1</b> <b>GS 8010-1</b>	<b>90</b>	<b>230</b>
<b>GS 11008-1</b> <b>GS 11010-1</b>	<b>170</b>	<b>290</b>
<b>GS 12008</b> <b>GS12010</b>	<b>180</b>	<b>320</b>

4. Go to the maintenance menu on the ISOBUS terminal. Press .
5. Go to the weighing system calibration menu. Press .



**CAUTION: Trapping**

**The drawbar and the suspension of the machine move in this procedure. Keep away from these parts.**

6. Start the calibration. Press  if you weigh the full machine, press  if you weigh the empty machine.
7. Record in the top input box the value that you wrote down.

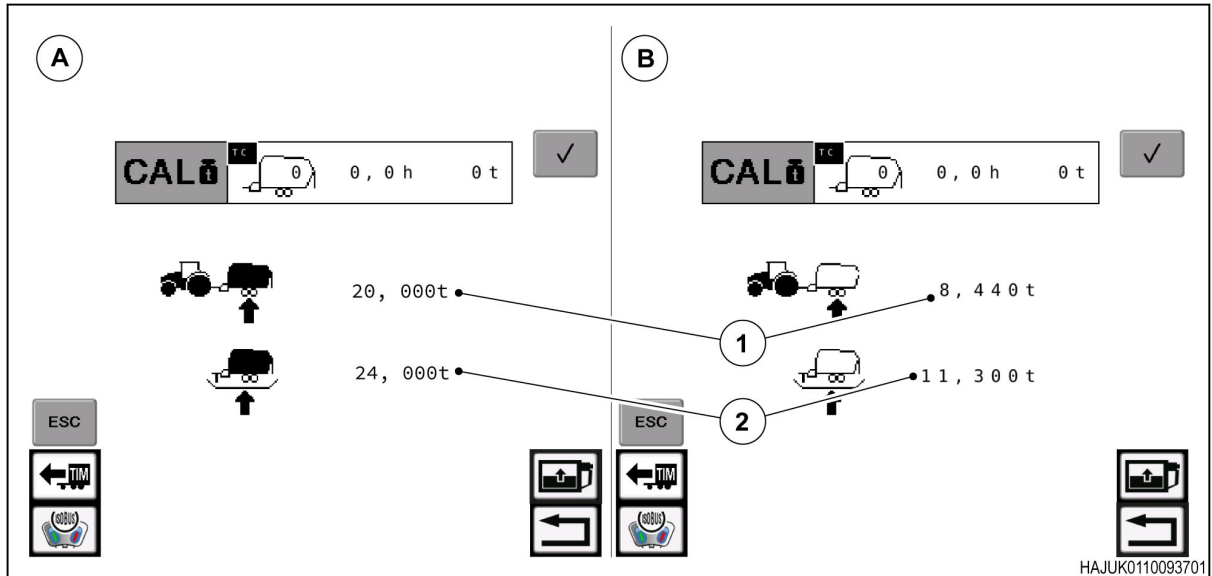



Fig. 56 Input boxes on the calibration menu

- (A) Calibration menu for a machine with a full load
- (B) Calibration menu for an empty machine
- (1) Top input box
- (2) Bottom input box

- "A" if you weighed the machine full
- "B" if you weighed the machine with no contents.

Refer to the manual of the ISOBUS terminal for how to record a value.

8. Record the value in the bottom input box:
  - If you weighed the machine full
  - If you weighed the machine no contents.
9. If the values are correct, press .

## 6 Specifications

<b>6.1</b>	<b>Specifications</b>	<b>183</b>
<b>6.2</b>	<b>Hydraulic Diagrams</b>	<b>185</b>
6.2.1	Icons Used in the Diagrams	185
6.2.2	Hydraulic Base Diagram	186
6.2.3	Hydraulic Diagram of the Pick-up Suspension (optional)	187
6.2.4	Hydraulic Diagram of the Hydropneumatic Suspension (optional)	187
6.2.5	Hydraulic Diagram of the Forced Steering System (optional)	188
6.2.6	Table of the Actuators	189
6.2.7	Layout of the Solenoid Valves	190
6.2.8	Control Diagram of the Solenoid Valves	190
<b>6.3</b>	<b>Electric Diagrams</b>	<b>192</b>
6.3.1	Abbreviations of Wire Colors and Wire Functions	192
6.3.2	Table of the Sensors	192
6.3.3	Junction Box	194
6.3.4	Wiring Loom X1 A-K	196
6.3.5	Wiring Loom X1 L-Y	198
6.3.6	Wiring Loom X2 A-K	200
6.3.7	Wiring Loom X2 L-Y	202
6.3.8	ISOBUS Cable X3	203
6.3.9	Standard Adapter Cable (LM98104156)	204
6.3.10	Lighting Diagram	206
<b>6.4</b>	<b>Tables of Standard Torques for Nuts and Bolts</b>	<b>207</b>
<b>6.5</b>	<b>Table of Standard Wheel Nut Torques</b>	<b>208</b>
<b>6.6</b>	<b>Table of Standard Tyre Pressures</b>	<b>209</b>



Pin	Wire colour	Connected to	Potential	Sensor senses/ measures
A1	Br	S22-1	+8.5 V DC	Knife assembly in the working position
A2	Bk	S22-4	Signal	
A3	Bl	S22-3	ECU GND	
B1	Br	S23-1-	+8.5 V DC	Pressure in the system of the tiltable bulkhead
B2	Bk	S23-4	Signal (4 - 20 mA)	
B3	Bl	S23-3	ECU GND	
BC1	Br	S24-1	+8.5 V DC	Wagon full
C2	Bk	S24-4	Signal	
C3	Bl	S24-3	ECU GND	
D1	Br	S26-1	+8.5 V DC	Tailgate closed
D2	Bk	S26-4	Signal	
D3	Bl	S26-3	ECU GND	
E1	Br	S27-1	+8.5 V DC	Tilt angle of the bulkhead
E2	Bk	S27-4	Signal (4 - 20 mA)	
E3	Bl	S27-3	ECU GND	
F1	Br	S29-1	+8.5 V DC	Tailgate open
F2	Bk	S29-4	Signal	
F3	Bl	S29-3	ECU GND	
G1	Br	S32-1	+8.5 V DC	Knife assembly in the service position
G2	Bk	S32-4	ECU GND	
G3	Bl	S32-3	GND	
H1			+8.5 V DC	
H2	Gn	S34-1	Signal	Trailed steering axle (optional) unlocked
H3	Rd	S34-2	ECU GND	
J1			+8.5 V DC	
J2	Gn	S40-1	Signal	The button on the carriage to move the knife assembly to the service position is pushed
J3	Rd	S40-2	ECU GND	
K1			+8.5 V DC	
K2	Gn	S39-1	Signal	The button on the carriage to move the knife assembly to the working position is pushed
K3	Rd	S39-2	ECU GND	

CLICK HERE TO **DOWNLOAD** THE COMPLETE MANUAL

- Thank you very much for reading the preview of the manual.
- You can download the complete manual from: [www.heydownloads.com](http://www.heydownloads.com) by clicking the link below



- Please note: If there is no response to CLICKING the link, please download this PDF first and then click on it.

CLICK HERE TO **DOWNLOAD** THE COMPLETE MANUAL