OPERATOR'S MANUAL

FENDT

FENDT 8370 P

FENDT 8370 P AL

FENDT 8400 P

FENDT 8400 P AL



CLICK HERE TO **DOWNLOAD** THE COMPLETE MANUAL

- Thank you very much for reading the preview of the manual.
- You can download the complete manual from: www.heydownloads.com by clicking the link below



- Please note: If there is no response to CLICKING the link, please download this PDF first and then click on it.

CLICK HERE TO **DOWNLOAD** THE COMPLETE MANUAL

1. General Information

1.1	Dear Customer	13
1.1.1	Appropriate Use	13
1.1.2	Changes and Improvements	13
1.1.3	Directives	13
1.1.4	Preface	14
1.1.5	EC Declaration of Conformity for Combine and Table	15
1.1.6	Product Identification	18
1.1.7	Sketch and parts identification	19
1.1.8	Disposal	20

Disposal of batteries

Batteries contain substances which, if not handled correctly, might be dangerous for the health of people and the environment. Batteries are marked with a decal depicting a crossed-out wheeled bin (fig. 7). It symbolises that worn-out batteries should be collected separately, rather than being disposed of with unsorted household waste.

It is important that worn-out batteries are handed in to the collection schemes which have been set up. This way it is ensured that batteries are reused according to legislation and that the environment is not unnecessarily affected. Among other places, worn-out batteries can be handed in to workshops which take back batteries, to local authorities which have set up collection schemes, i.e. at recycling centres, or to receiving stations established by battery manufacturers.

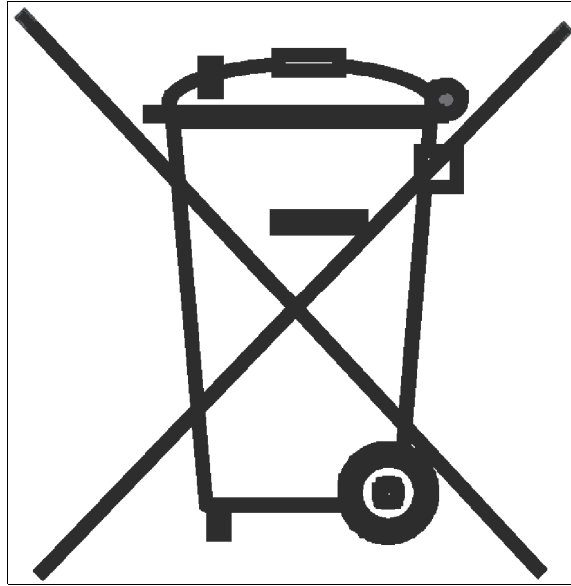
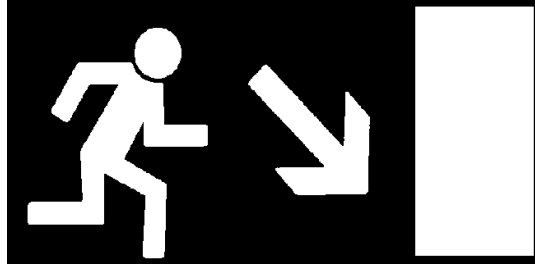

Fig. 7.

I018222

1

On the right-hand side window.
[Emergency exit.]



At the straw walker drive.

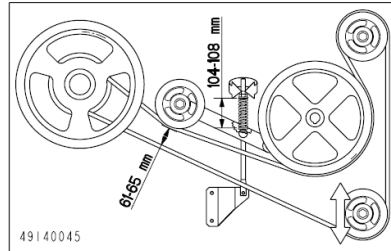

On the Maxi Spreader, engine hood and grain tank covers.
[Do not step.]

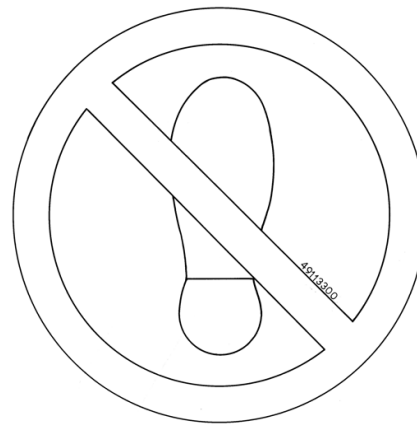

On the right-hand side of the main crop elevator.

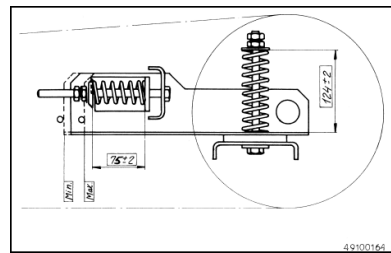

2.1.6 CE Marking and Type Plate on the Combine

T006491

See drawings at the end of this chapter.

IMPORTANT: Renew decals that have been damaged, lost, painted out or otherwise have become illegible. If components that originally held decals are replaced, make sure that new decals are fitted on the new components.

NOTE: New decals can be ordered from your dealer.

Left-hand side:

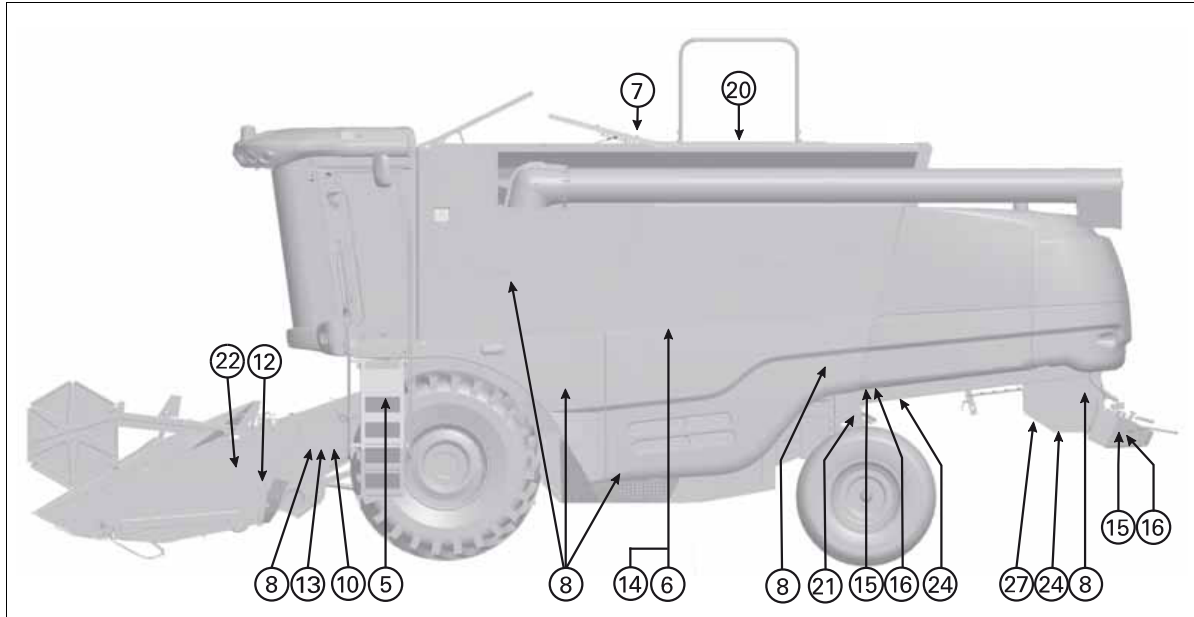

Fig. 3.

I015656

2

Right-hand side:

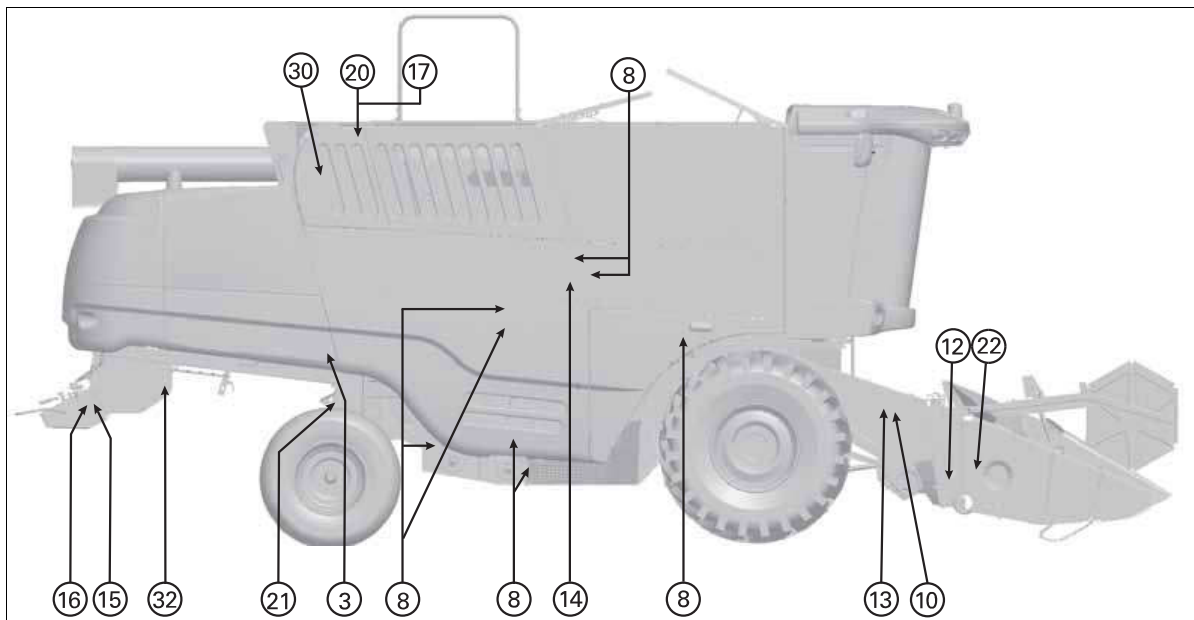















Fig. 4.

I015657

3.3 Safety Precautions - on the Move

3.3.1 Safety Precautions - on the Move

T006055

-  **WARNING:**
Never start the machine unless persons near the machine are aware of your intentions to start. Check the immediate surroundings before starting - Children!
-  **WARNING:**
Never start the machine unless all safety guards are fitted and secured.
-  **WARNING:**
During road transport the switch for multifunction lever and cutting height control must be switched off, to avoid unintentional lowering of main crop elevator and table.
-  **WARNING:**
Never adjust the steering column on the move.
-  **WARNING:**
Never adjust the operator seat on the move.
-  **WARNING:**
During transport, the ladder must be turned in front of the operator cab.
-  **WARNING:**
Be particularly cautious when driving downhill with full grain tank. Never change to higher than 2nd gear. Never change into neutral. Stop the machine slowly.
-  **WARNING:**
Never travel downhill in neutral gear, always change into low gear (engine braking effect!). Always gear down before starting downhill.
-  **WARNING:**
Repairs of the cooling system to be carried out only by cooling system specialists.
-  **WARNING:**
Avoid any contact with liquid refrigerant.
-  **WARNING:**
See a doctor immediately in case of sprays in the eyes.
-  **WARNING:**
Never leave the combine unattended without stopping the engine, setting the multifunction lever into neutral and applying the parking brake. Lower table and main crop elevator completely, remove ignition key and main switch handle from the switches.
-  **WARNING:**
On slopes secure the combine against rolling by applying the parking brake and/or inserting sprags under the wheels.
-  **WARNING:**
The unloading auger must always be turned completely in during road transport.

3.6.4 Safety switch in operator seat - (Operator Present Switch)

T006100

The operator seat is equipped with a seat switch to prevent unintended movement of the combine and operation of its mechanical parts. The seat switch prevents the combine from moving when the operator is not present.

The seat switch is OFF when the operator is not in his seat and ON when the operator seat is pressed down. In this way the operator can operate the mechanical combine functions only while he is sitting in his seat.

When the seat switch is deactivated, an alarm (top picture *fig. 3*) is set off in FIELDSTAR after which the mechanical functions of the combine are switched off with the following delays:

1. Hydrostatic transmission: 4 seconds
2. All table functions: 7 seconds
3. Threshing unit: 8 seconds
4. Unloading auger: 8 seconds

If the operator leaves his seat on the move and the seat switch activates the stop function, the full functionality of the combine can only be reinstated proceeding as follows:

1. The operator must sit down in his seat
2. Move the multifunction lever in neutral position
3. Switch off the threshing unit switch
4. Switch off the table switch
5. Switch off the unloading auger switch

Then all combine functions can be operated again.

The procedure can also be seen from the warning (bottom picture *fig. 3*) appearing on the terminal when the safety stop comes into operation.

WARNING:
Do not make any changes which may put the safety function out of operation. In case of failure, contact your dealer immediately.

3

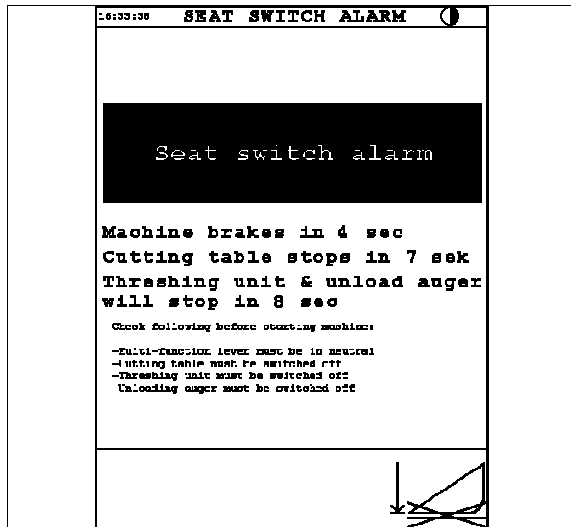

I014985

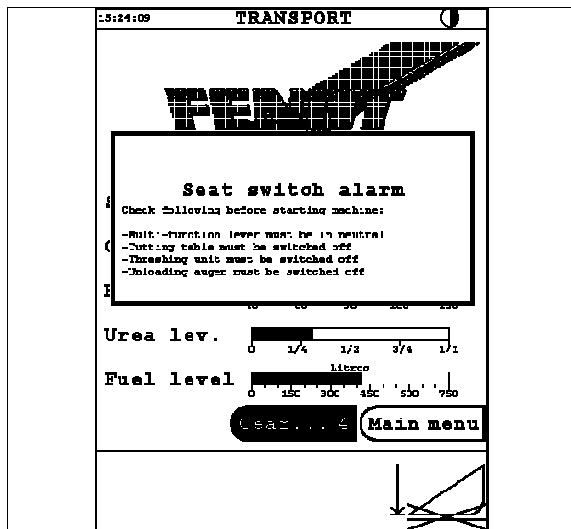

I022969

Fig. 3.

3.11 Climate control

3.11.1 Maintenance and overview

T005637

Cleaning of filter

(fig. 1)

The cab roof is fitted with fresh-air blower, filter and climate control. The air is taken in through the grating (1) on both sides of the filter (2).

To clean the filter, remove the cover (3) on the left-hand side of the cab roof by loosening the catches. Open the rubber straps (4) and take out the filter (2) for cleaning. Replace the cover after cleaning. The climate control is operated from the control panel (5).

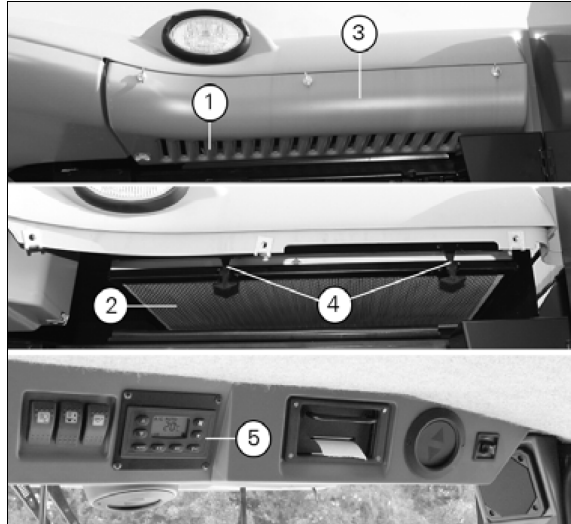

Fig. 1.

I016595

3

Components of the climate control

(fig. 2)

1. Cooling unit/heating
2. Expansion valve
3. Condenser
4. Pressostat for high and low pressure
5. Filter and sight glass
6. Compressor
7. Magnetic clutch
8. Fanning mill
9. Adjustable in-take for recirculation of the air in the cab
10. Adjustable defroster opening

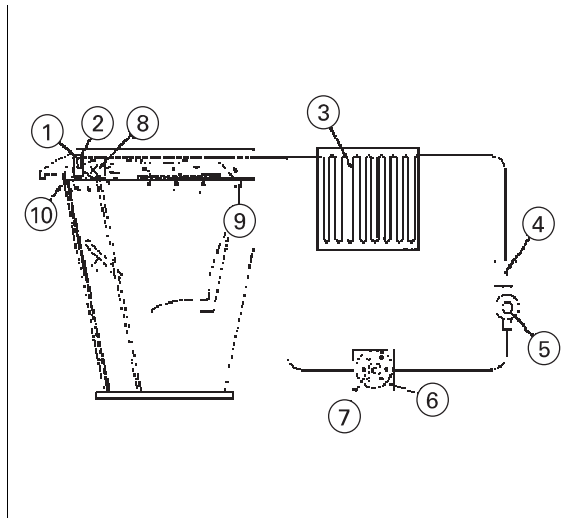

Fig. 2.

I016619

4.1 Safety precautions

4.1.1 Safety precautions, Operating FIELDSTAR

T006056

**WARNING:**

Before any service or cleaning is carried out, stop the engine, remove the ignition key and switch off the main switch.

**WARNING:**

Never carry out any electric welding on the machine until the engine is stopped, the ignition key is removed and the main switch is switched off. Disconnect the alternator cables to protect the alternator.

Disconnect all connectors for:

- Terminal and job computers in the electric box
- Comunit or GPS
- EEM engine control computer

**WARNING:**

Never allow persons near the machine and never reach into the elevator to check the returns. Dismounting and mounting of elevator shutters must not take place before the diesel engine has been stopped and the main switch has been switched off.

Shortcuts

(fig. 4)

By pressing the bar of the following functions you can move directly to the settings menu of the functions:

- Returns volume
- Loss
- Fanning mill
- Sieve*
- Cylinder speed

*For electrically adjustable sieves only.

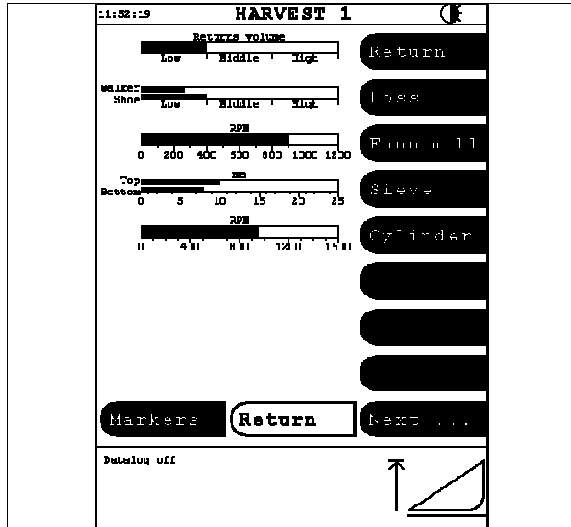

Fig. 4.

I014906





4

Shortcut keys

(fig. 5)

From the Harvest menu it is possible to select the display of shortcut keys. Select a function from the Harvest menu and replace it by "Shortcut keys".

Overview of shortcut keys:

-  Data logging
-  Harvest settings
-  Table settings
-  Machine settings

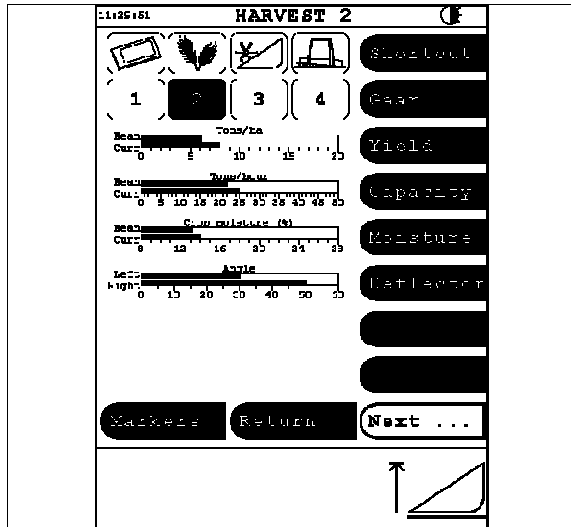

I014916

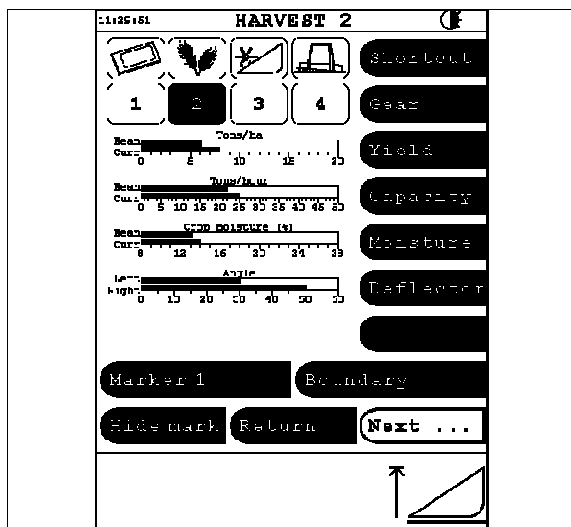

Fig. 5.

I014917

Special functions

(fig. 5)

Job data without yield meter and moisture meter, [fig. 3](#)

Up to 14 different jobs can be handled on each data card and the following data can be recorded for each job: Field name, Operation (Harvest), Job No., Job start, Hours, Area.

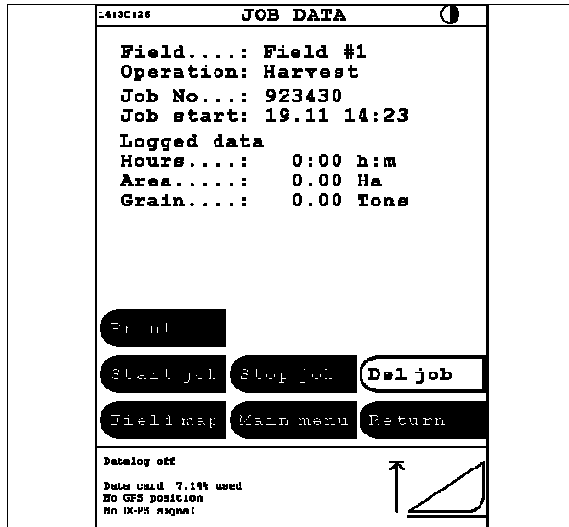

Fig. 3.

I014888

Job data with yield meter and moisture meter, [fig. 4](#)

If the machine is equipped with yield meter and moisture meter, the following additional data can be recorded: Grain, Yield, Average moisture, Dry grain, Dry yield, Crop type.

The recorded data can be printed out if the machine is equipped with a printer.

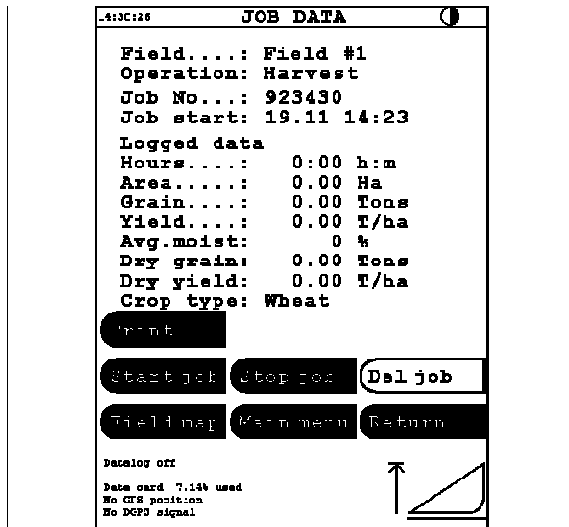

Fig. 4.

I014926

4

4.6.3 Using Data Logging

T006081

Creating a New Field Job

To create a new field job, insert the data card in the terminal while the machine is running. The screen automatically changes to the data logging menu. The screen picture "Data logging" can also be called up by selecting the menu "Harvesting data | Data logging". The data card must be formatted using Fieldstar Office Software version 4.0 or higher.

"New Job", [fig. 5](#)

Press the key "New job" to call up a list of field names.

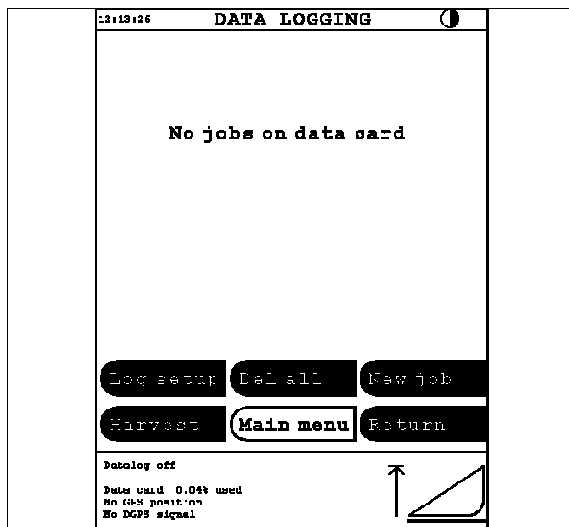

Fig. 5.

I014944

4.6.5 Using Markers

T006083

During the execution of a job the marker keys can be used for recording various observations in the field. When a marker key is pressed (e.g. [fig. 28](#)) machine position is logged together with a text/value selected for the marker.

If the marker has the property 'Marker without value', it can be used for marking an area in the field. When you hold the marker key for about 2 seconds, the logging starts, and a single touch of the marker key will stop the logging of the specific area. The marker text at the bottom of the screen will flash in the period between the two touches.

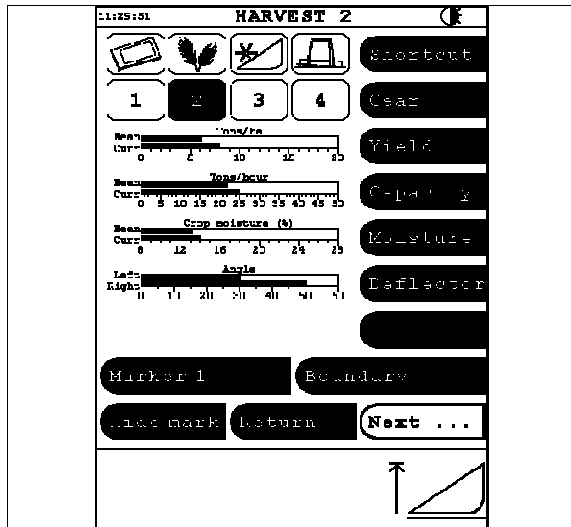

4

Fig. 28.

I014917

If the required function is not on the screen, press "Next..."

4.9.2 Clock Adjustment

T006261

(fig. 1)

Select "Clock adjustment under Coding" to call up a calculator menu in which date and hour can be entered.

If the combine is equipped with GPS, the clock can be adjusted according to GPS time by pressing the "GPS" key, shown in "Clock adjustment" picture 2 in (fig. 1), and pressing "OK". If GPS time is not to be used, press "C" or "Cancel".

4.9.3 Language

T006262

(fig. 1)

Call up the menu "Coding | Language". When the key of the desired language is pressed, the texts on the screen change accordingly.

NOTE: The following setup requires a programming card. Therefore, the deletion of a language should be considered carefully.

Additional languages can be inserted on the terminal which gives you a choice of a total of three. The languages can be upgraded to a later version independent of the other software. The version number appears on the language key in the above menu. Deletion of languages is possible only when a programming card is inserted or when the deletion is confirmed by entering the machine ID number. The last remaining language cannot be deleted.

4.9.4 Area Measuring

T006263

To ensure accurate area measuring, table width and wheel circumference can be set with an interval of 1 cm, (fig. 2).

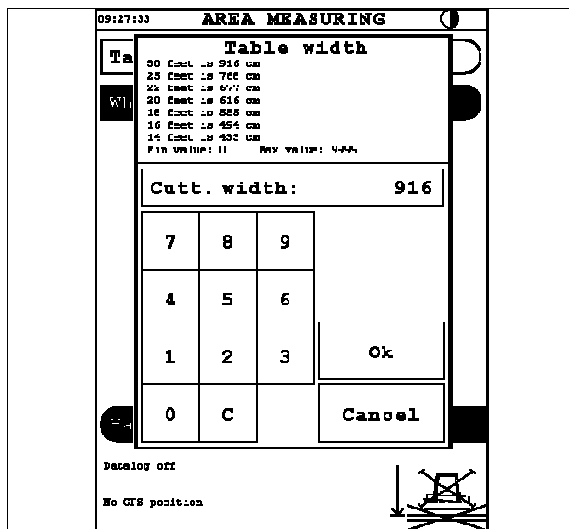

Fig. 2.

I023133

Adjustment of Electrical Sieves

Call up the menu "Harvest settings | Electrical sieve" to adjust the sieve opening. The sieve opening is adjusted by mm using the "+/-" keys for both top and bottom sieves. The sieves are divided into two parts - a right-hand and a left-hand sieve. See (fig. 4). The bar shows at the top the selected sieve opening, and at the bottom the current opening. The sieve opening can be changed when the threshing unit is engaged.

NOTE: Being closed, the sieve will first move into a position 3 mm below the selected position. This is to ensure that the sieve is always adjusted from below.

The grain loss indicator is shown in the menu allowing the operator to check how the sieve adjustment affects the loss (shaker shoe loss only).

The key "Select" is used for selecting which sieve to adjust with the "+/-" key. This is indicated by a '>' mark in front of the selected sieve(s). When the menu is called up again, both sieves will always be selected.

NOTE: A difference of sieve opening between the right-hand and left-hand sieves is maintained until it is changed/removed manually or the sieves are completely closed or opened.

Adjustment of Sieve Extension, fig. 5

Adjustment of the sieve extension is carried out manually using the lever (1) and cannot be read on the terminal. The sieve extension will follow the adjustment of the top sieve, even if there is a difference of opening between the sieve extension and the top sieve. However, the difference will be removed if the sieve extension reaches its end stop.

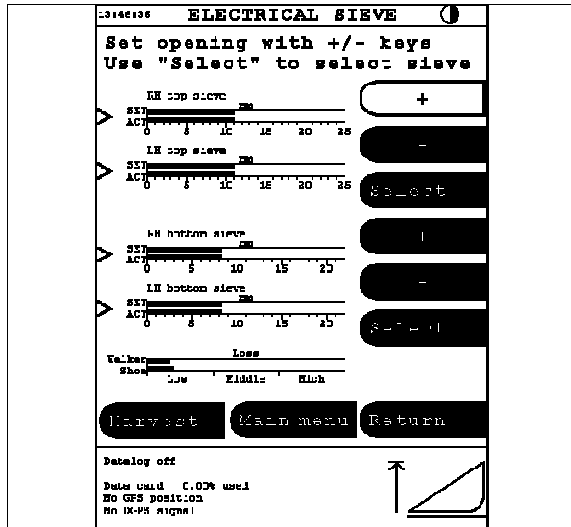

Fig. 4.

I014973

4

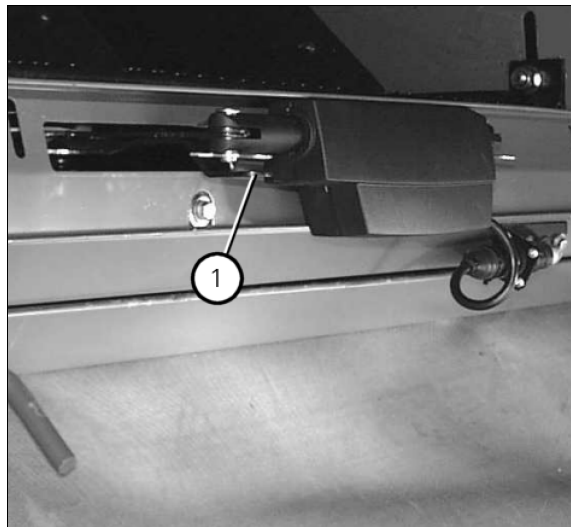

Fig. 5.

I015892

4.13 Shaft Alarm Limits

4.13.1 Shaft alarm calibration

T005698

If changes are made to the shaft system, the monitoring system must 'learn' the new shaft speeds in order for the shaft monitoring to function correctly.

The procedure appears from the menu "Coding | Shaft alarm calibr."

Follow the instructions on the screen (fig. 1).

When calibrating the alarm limits for shaft speeds, threshing unit, table, unloading auger and straw chopper (if mounted) must be engaged to ensure that all combine shafts are calibrated. Furthermore, the engine must normally run at max. revolutions, and the machine must be stationary.

WARNING:
 Always leave at least one door open for ventilation if the diesel engine is started in a workshop/machine shed without air suction ventilator.

WARNING:
 Never start the machine until all safety guards are fitted and secured.

WARNING:
 Table and chopper knives are moving violently during calibration. Never allow people near the front or back of the machine while calibration is carried out.

Calibration of shaft alarm limits for fanning mill and cylinder variator is not required. The previous alarm limits are still used.

The current and latest calibrated shaft speeds can be read from the menu "Coding | Shaft alarm calibr. | Current", (fig. 2).

4

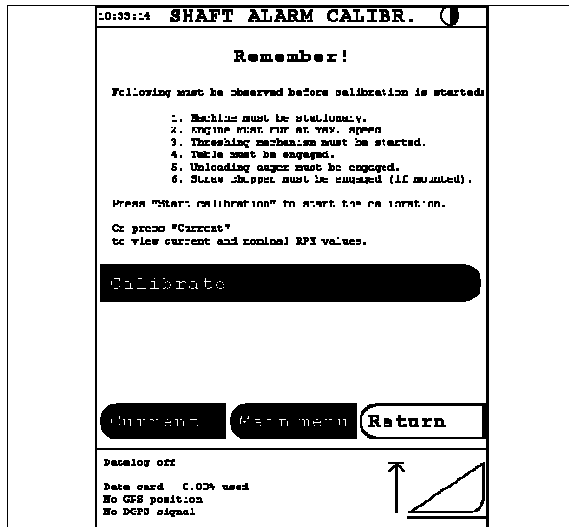

Fig. 1.

I014871

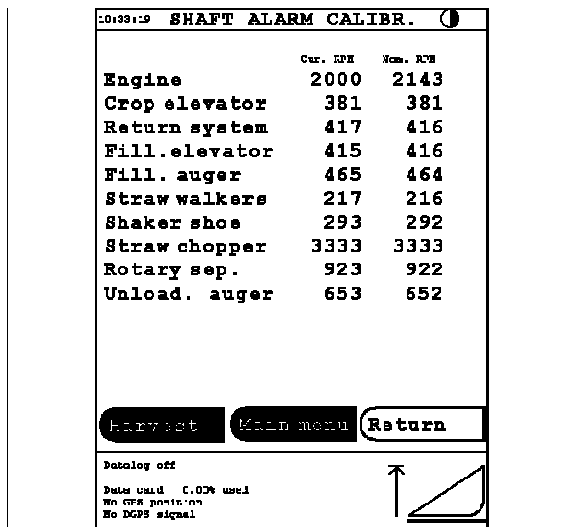

Fig. 2.

I014872

Check from the dialog box (fig. 5) that the calibration figure has been changed and press "Ja" to store the change.

Now, the screen returns to "Crop calibration" for wheat (top picture fig. 3) from which it appears that the calibration figure has been changed from 1008 to 1020.

The moisture meter calibration figure for wheat will remain 1020 until a new calibration is carried out.

The calibration figure can also be keyed in directly from the menu "Moisture calib. figure" (top picture fig. 3).

Failure Alarms:

- **Moisture sensor missing:**
No signal from the moisture meter. Cable or moisture meter defective.
- **Sample too wet:**
The crop sample is too wet for the moisture meter to determine the water content.
- **Moisture sensor error:**
The level sensor of the moisture meter indicating by a constant light that the moisture meter is full although it ought to be empty. This may be caused by too much material in the moisture meter which cannot be emptied, or the level sensor being dirty or defective. Dismount and clean the moisture meter as previously described.
If the failure alarm "Moisture sensor error" appears when the combine is started, the cause may also be water or dew having penetrated into the moisture meter while the combine was parked.

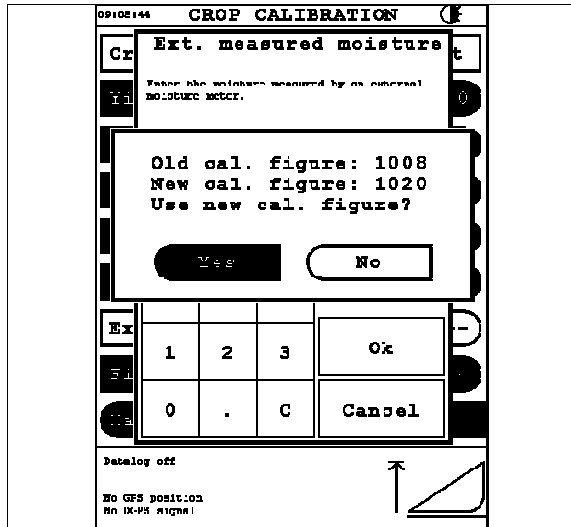

Fig. 5.

I014904

4.19.2 Bleeding

T006302

Start the diesel engine, move the main crop elevator completely to the right and then completely to the left using the switch (2) (top picture [fig. 2](#)).

Then move the main crop elevator back until the adapter (3) is level.

Normally, this should be done only once, when the machine is new, or if the hydraulic system has been disassembled for repair, to ensure that the system is completely bled.



I022403

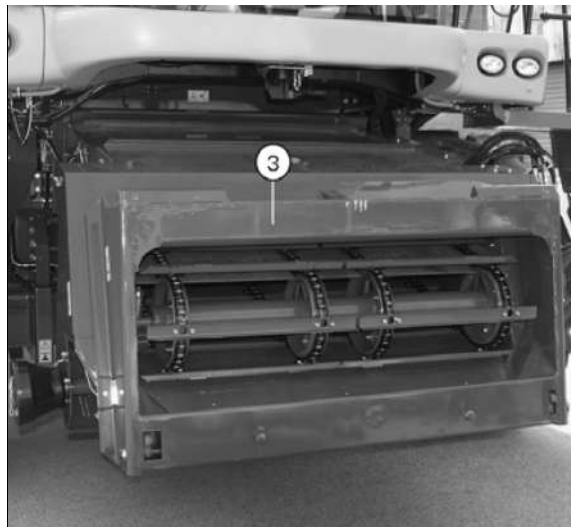

I016695

Fig. 2.

4

4.22.3 Constant Flow Engagement

T005729

Now Constant Flow can be engaged to automatically adjust the forward speed in relation to the cylinder load. This is done with the "On / Off" key in the menu "Machine settings | Constant Flow".

When Constant Flow is "On" the speed bar in the Harvest menu will be shown as a double bar. The top value is the desired speed calculated by Constant Flow on the basis of the given conditions. The bottom value is the current speed, please see (fig. 4).

Having engaged Constant Flow push the multifunction lever slightly forward to allow the system to increase speed if the crop volume/load is reduced. Push the lever so far forward that Constant Flow is able to increase the speed by approx. 2 km/h. If harvest conditions permit a higher speed, the lever may be pushed further forward.

Then the automatic function will control the forward speed keeping the bars for "SET" and "ACT" loads equal, please see (fig. 4).

The control range of Constant Flow is approx. 4 km/h. This is indicated by an "x" and an "X" on the speed bar. For instance, there may be an "x" at 3 km/h and an "X" at 7 km/h, the small "x" indicating the minimum speed for Constant Flow control, whereas the large "X" indicates the maximum speed for Constant Flow which will always follow the position of the multifunction lever.

By pushing the multifunction lever forward it is possible to "force" the machine to run faster than the speed calculated by Constant Flow. This is useful, for instance when the grain tank is unloaded on the move and the grain waggon is travelling a little to fast. Besides, it is always possible to reduce the speed by pulling the multifunction lever towards neutral.

When Constant Flow is engaged, the text "LIMIT" will appear on the screen if the maximum speed permitted by the position of the multi-function lever is reached (fig. 5).

The position of the multifunction lever will always set the upper limit to how much Constant Flow can increase the speed to keep the preset cylinder load. The operator is always able to intervene and reduce forward speed using the multifunction lever without disengaging Constant Flow.

4

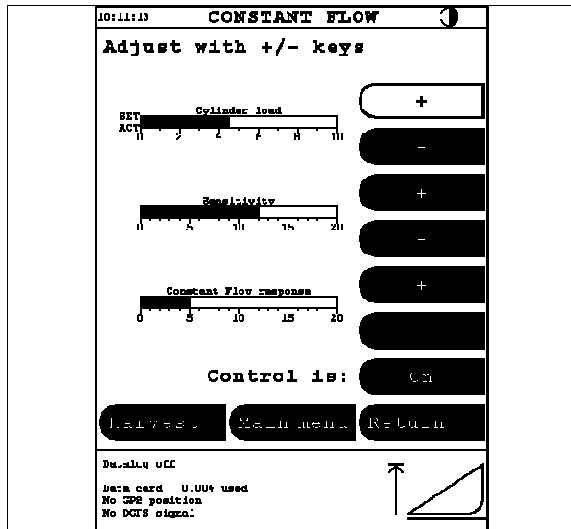

I014960

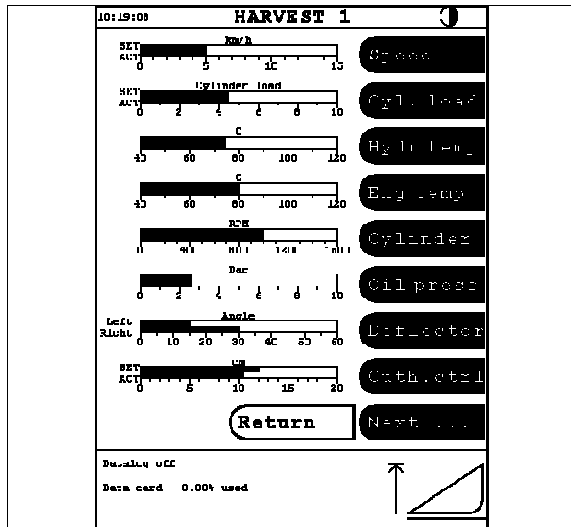

Fig. 4.

I014913

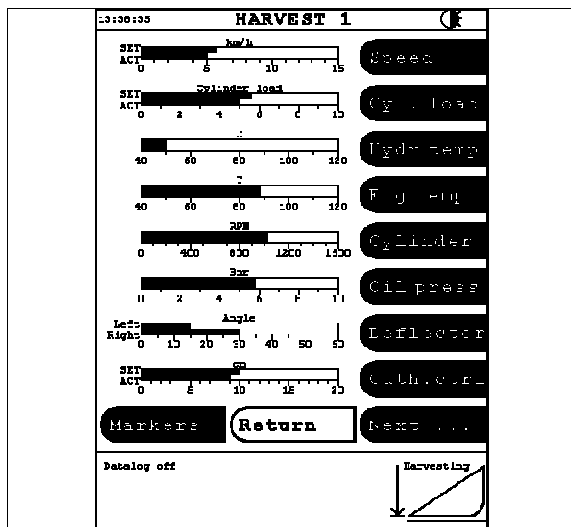

Fig. 5.

I014911

5.5 Auto Level Combine/Table

5.5.1 Combine

T005653

(fig. 1)

The position of the combine is changed by turning the final drives (1) by means of two double-acting hydraulic rams (2).

In working position the rams are halfway between their two extreme positions and the machine height is 4.1 m.

In transport the machine must be lowered into bottom position in which the machine height is 4 m.

Raised into top position the machine reaches a height of 4.3 m.

Both rams are fitted with valves which block up the rams in case of a breach on a hose or the like.

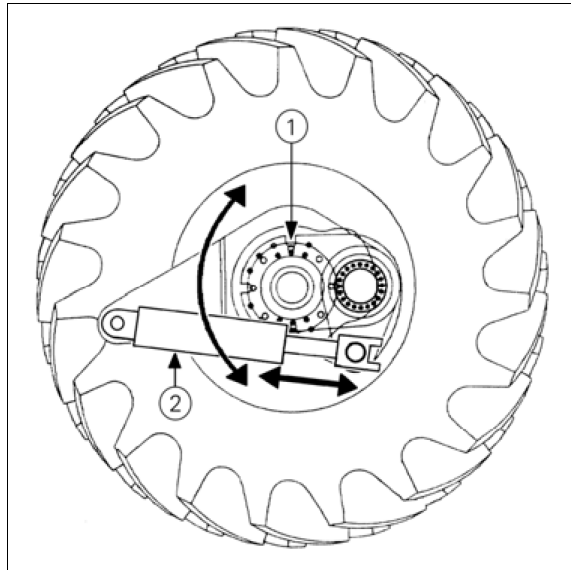

Fig. 1.

I016741

5

<p>Machine Not Levelling Correctly</p>	
<p>Table Not Parallel with Traction Wheels - Auto Level Table Not Engaged.</p>	<p>Possible cause:</p> <ol style="list-style-type: none"> 1. Track width or machine type wrongly entered. Check coding. 2. Wrong signal from potentiometer. Check potentiometer on main crop elevator. Carry through calibration of Auto Level combine and table on level ground (see §5.6.1, page 184 and see §5.6.2, page 185).
<p>Table Not Parallel with the Ground - Auto Level Table Engaged.</p>	<p>Possible cause:</p> <ol style="list-style-type: none"> 1. Ground sensors unable to work freely. Check ground sensors. 2. Wrong adjustment/calibration of Auto Level table. Check adjustment of potentiometer under "Diagnostics Control Auto Level Table". Zero Auto Level table under "Coding Table calibration Zero cutting height" (see §5.7.1, page 186, see §5.7.2, page 186 and see 4.9, page 120). 3. Potentiometer defective. Check adjustment of potentiometer under "Diagnostics Control Auto Level Table". Check that the bar on the screen is level when the table is raised/lowered. 4. Connecting rods defective - Check. 5. Wiring harness defective - Check.
<p>Table Following the Ground Very Irregularly - Auto Level Combine and Auto Level Table Engaged and Active.</p>	<p>Possible cause:</p> <ol style="list-style-type: none"> 1. Wrong signal from ground sensors. 2. Fault in throttling to Auto Level combine. 3. Fault in throttling to Auto Level table. <p>Check:</p> <ol style="list-style-type: none"> 1. See above. 2. Place the machine on level ground with empty grain tank, table being attached. Check how long time it takes to: <ul style="list-style-type: none"> - Tilt the machine completely from left to right. Must take 7 ±1 seconds. - Tilt the machine completely from right to left. Must take 7 ±1 seconds. 3. Place the machine on level ground, table being attached. Check how long time it takes to: <ul style="list-style-type: none"> - Tilt the table completely from left to right. Must take 8 ±1 seconds. - Tilt the table completely from right to left. Must take 8 ±1 seconds. 4. Check throttling according to hydraulics diagram.



6.4.3 Coolant

T006128

(fig. 3)

In total, the cooling system contains approx. 45 litres (50% anti-freeze + 50% water).

On delivery the cooling system has been filled with anti-freeze and corrosion inhibiting solution to protect the cooling system down to approx. -35°C corresponding to a mixture ratio of 1:1. If the coolant level gets too low, an alarm appears in FIELDSTAR. Refill as required and change coolant every second year as its corrosion and frost protecting effect decreases with use.

NOTE: Note that the mixture ratio of 1:1 must be observed when refilling and changing coolant. Apply only pure, preferably soft water and anti-freeze/corrosion-inhibiting solution which meets the requirements of ASTM D 3306 or BS6580:1992 standards.



WARNING:

Never remove the cap from a hot engine. Allow radiator and engine to cool down before relieving the pressure.

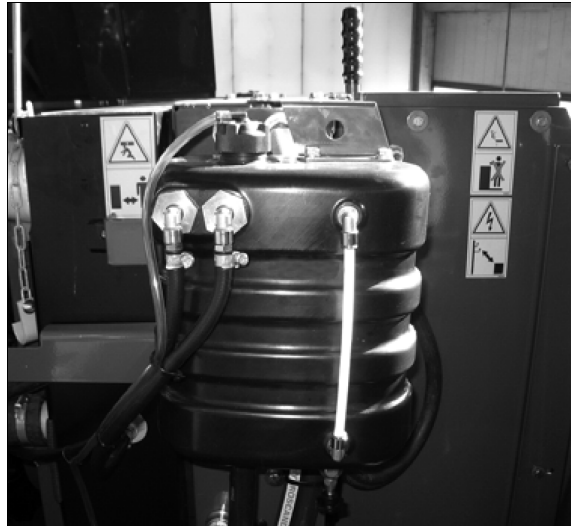

Fig. 3.

I029345

6

6.4.4 Checking the fan belt tension

T006127

(fig. 4)

The engine is equipped with a spring-loaded tensioner, and the belt is a Poly-V type. The belt is automatically tensioned during operation.

Visually check the belt. Replace a worn, oily or damaged belt.

NOTE: Clean the alternators regularly outside/inside with compressed air.

Dust on and inside the alternators may cause damage.

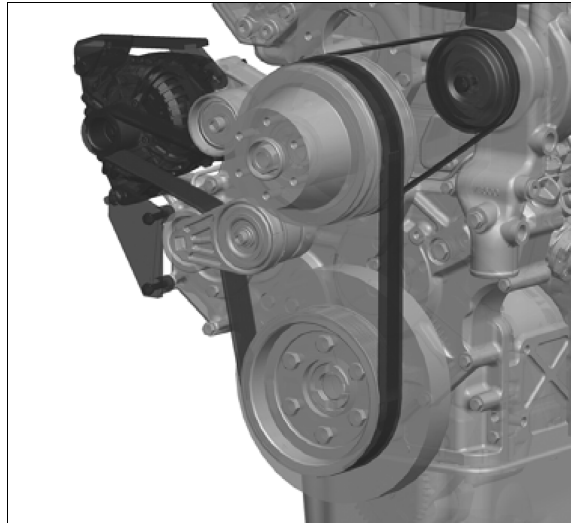

Fig. 4.

I016820

**WARNING:**

Never install a used and/or wet equalising element as this will result in poor filtration.

5. Refit the filter cap and, using a 27 mm wrench, tighten to $22,5 \text{ Nm} \pm 2,5 \text{ Nm}$.

Used equalising elements must always be disposed of in a safe way.

NOTE: Always check for cracks around the filter cap when changing the equalising element.

- If there are cracks in the supply module housing, the entire supply module must be replaced.
- In case of cracks in the filter cap, replace it.

In addition to the filters in the supply module, the tank sensor and the dosing module are equipped with mesh-type filters. Normally, replacement of these filters is not necessary.

NOTE: The AGCO SISU POWER SCR is equipped with a built-in diagnosis system that alerts the operator or reduces the engine power through the EEM4 system in case of problems (e.g. leakage or clogged hoses) in the system.

6

6.6.5 SCR system failure

T013247

The SCR system is equipped with a number of different sensors for the purpose of monitoring the system. If the sensor registers a problem, the engine management system is alerted through the CAN bus and the ECU releases an error message. In consequence, the engine power may be reduced. For further details on these error messages see [6.10, page 215](#).

The most common causes of SCR system failure are:

- Empty AdBlue tank
- Clogged filters and/or hoses
- Clogged dosing module
- AdBlue quality problem
- Defective sensors

In the armrest control panel there is a pilot lamp for the AdBlue level (1) and one for SCR system failure (2). In addition, an acoustic signal will sound in the operator cab.



Fig. 4.

I031180

CLICK HERE TO **DOWNLOAD** THE COMPLETE MANUAL

- Thank you very much for reading the preview of the manual.
- You can download the complete manual from: www.heydownloads.com by clicking the link below



- Please note: If there is no response to CLICKING the link, please download this PDF first and then click on it.

CLICK HERE TO **DOWNLOAD** THE COMPLETE MANUAL

SPN	FMI	Degradation	Shut down	Failure Description
520202	3			ECU main relay 1 short-circuit to HIGH SOURCE
520203	3			ECU main relay 2 short-circuit to HIGH SOURCE
Air filter pressure monitoring				
107	18			Air filter pressure BELOW NORMAL
107	31			Air filter pressure sensor active at initial state
Battery voltage				
168	3			Battery voltage sensor voltage above normal
168	4			Battery voltage sensor voltage below normal
168	0			Battery voltage ABOVE NORMAL (>17 V(12V)) (>32 V(24V))
168	1			Battery voltage BELOW NORMAL (<78 V)
Throttle 1				
91	4			Throttle 1 sensor below normal (IDLE)
91	3			Throttle 1 sensor above normal or open circuit (IDLE)
Throttle 2				
29	4			Throttle 2 sensor below normal (IDLE)
29	3			Throttle 2 sensor above normal or open circuit (IDLE)
Throttle 3				
974	4			Throttle 3 sensor below normal (IDLE)
974	3			Throttle 3 sensor above normal or open circuit (IDLE)
Rail pressure monitoring				
157	17	3		Rail pressure controller, negative deviation
157	15	3		Rail pressure controller, positive deviation
157	31	3		Rail pressure, leakage detected by quantity balance
157	18	3		Rail pressure below normal
157	0	3	X	Rail pressure above normal
Pressure relief valve				
520408	31	3		Rail PRV recognised as OPEN



7. Cutting Tables

7.1	Safety precautions	233
7.1.1	Safety Precautions, Cutting Tables	233
7.2	Attachment/Removal of Table	234
7.2.1	Attachment of Table, Standard and Auto Level	234
7.2.2	Removal of Table	235
7.2.3	Supports	236
7.3	Table trailer	237
7.3.1	Attachment of combine and trailer	237
7.3.2	Table Trailer Brakes	237
7.4	Reel	238
7.4.1	Reel Adjustment Up/Down, Fore/Aft	238
7.4.2	Bleeding	239
7.4.3	Reel Rotation	239
7.4.4	Reel tine bars	240
7.4.5	Adjustment of the Reel in the Table	240
7.5	Knife	241
7.5.1	Knife and knife drive	241
7.6	Feeding	242
7.6.1	Table auger	242
7.6.2	Cut-off strip and distribution strip	243
7.6.3	Replacement of Feathering Fingers	244
7.6.4	Auger Flight Extensions, 20-22-25-30' Tables	244
7.6.5	Reversing	245
7.7	Transmission	246
7.7.1	PowerFlow table, knife drive and table auger	246
7.7.2	Slip Clutch for Table Auger	246
7.8	PowerFlow Table	247
7.8.1	PowerFlow belts	247
7.8.2	Inspection and Start-Up of Powerflow Belts	247
7.8.3	Adjustment of belts	248
7.8.4	Scrapers, front	248
7.8.5	Scrapers, Rear, and Adjustment of Bearing Housings	249
7.8.6	Table Bottom	249
7.8.7	Cleaning	250
7.9	Crop lifters	251
7.9.1	Using Crop Lifters	251
7.10	Vertical Knives, Rape Auger and Straw Dividers	252
7.10.1	Vertical knife	252
7.10.2	Mounting of Vertical Knife	252
7.10.3	Rape auger	253
7.10.4	Folding torpedo dividers and bow dividers	253
7.10.5	Mounting of Straw Dividers	254
7.10.6	Adjustment of Torpedo Divider	254
7.11	Fixed Table Auger Fingers	255
7.11.1	Fitting of fixed table auger fingers	255
7.11.2	Using Fixed Table Auger Fingers	255
7.11.3	High Table Sides	255
7.12	Main crop elevator	257
7.12.1	Elevator Chain	257
7.12.2	Transmission for Table	258
7.12.3	Stone Trap	258
7.12.4	Initial Adjustment of Cutting Height Indication	259



7.5 Knife

7.5.1 Knife and knife drive

T005681

(fig. 1)

Inspect knife and fingers daily.

Replace damaged knife sections and fingers. Dismount the screws (1) to remove or replace the knife.

WARNING:
Always wear gloves when exchanging knives.

If fingers and knife are not functioning properly, the knife drive may get overloaded.

WARNING:
Be particularly cautious when dismantling the knives if they are jammed due to damage or the like.

Adjustment of knife

The height of the knife is adjusted by slackening the screw (2).

The position of the knife in the finger is adjusted by slackening the screws (3) and moving the gearbox in the slotted holes.

Retighten all screws to the torque indicated on the decal, [see §2.1.5, page 28](#).

Ensure that in the first finger there is a clearance between knife back and knife guide and between knife and finger.

NOTE: When changing knife, ensure that the knife sections are in contact with the fingers without pressing against them.

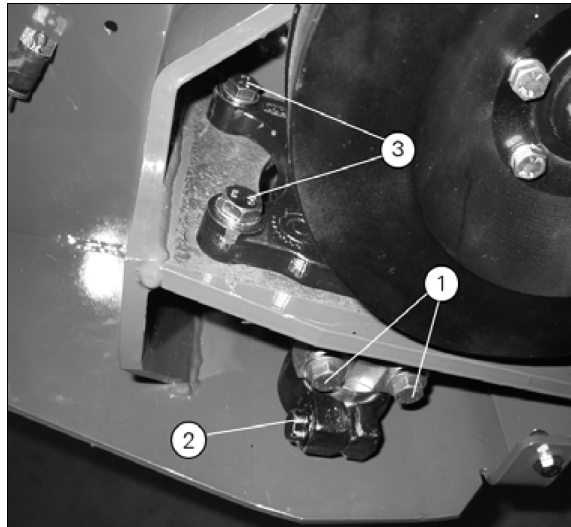

I016847

7

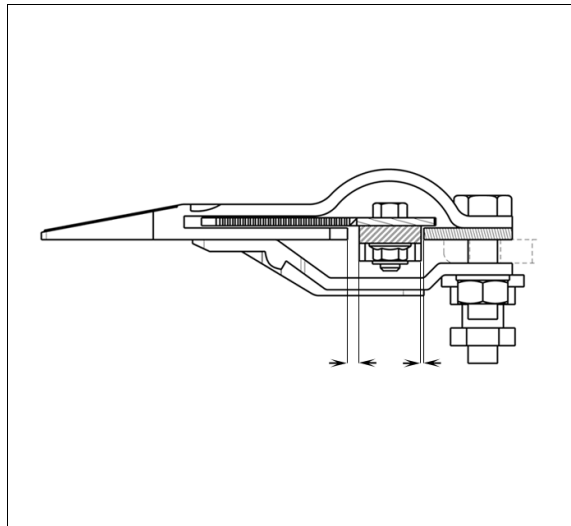

I016856

Fig. 1.

7.9 Crop lifters

7.9.1 Using Crop Lifters

T005688

(fig. 1)

The crop lifters are applied in partially or completely laid and in swathed crops.

Normally one crop lifter is fitted per foot cutting width (on every 4th finger). In certain cases it may be necessary to fit one crop lifter on every 2nd finger to avoid cutting off ears.

Always keep the two outermost fingers on both sides free of crop lifters.

Attachment

Push the fork home into the groove (1), lift the crop lifter (2) over the finger (3) and secure it with the spring (4) in the middle hole.

Adjust the cutting height so that the crop lifter touches the ground. If the cutting height is too low, the crop lifter will run over the crop.

Removal

Lift the crop lifter (2) and pull off the springs (4).

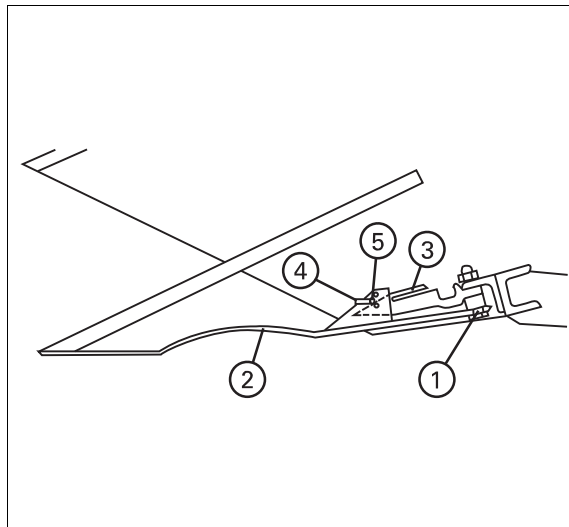

Fig. 1.

I016829

7

8. Operation of Table and Threshing Unit

8.1	Safety precautions	263
8.1.1	Safety Precautions, Operation of Machine and Cutting Table	263
8.2	Operation of Table	265
8.2.1	Table Height and Table Automatic Control	265
8.2.2	Cutting Height Control	266
8.2.3	Field Pressure Control	267
8.2.4	Preset cutting height	268
8.2.5	Auto Level table	268
8.2.6	Table Engagement - Emergency Stop	269
8.3	Threshing Unit Transmission	270
8.3.1	Threshing unit engagement	270
8.3.2	Cylinder Variator	271
8.3.3	Turning Tool for Cylinder	271
8.4	Concave Setting, Electrically Adjustable	272
8.4.1	Operation of Concave	272
8.4.2	Concave Setting	272
8.5	Threshing	274
8.5.1	Concave filler plates	274
8.5.2	Straw walkers	274
8.5.3	Rear beater curtain	275
8.6	Straw Chopper and Spreader Hood	276
8.6.1	Straw chopper	276
8.6.2	Adjustment of spreader hood	278
8.6.3	Counter Knives and Cross Bar	279
8.6.4	Replacement of Knives	281
8.7	Fanning Mill and Sieves	282
8.7.1	Fanning mill	282
8.7.2	Shaker shoe	282
8.7.3	Shaker Shoe with Electrical Sieves	283
8.7.4	Manual Adjustment of Sieves	283
8.7.5	Cleaning of Sieves and Main Grain Pan	284
8.7.6	Cleaning the Sieves	285
8.7.7	Shaker Shoe Light	287
8.7.8	Special sieves	287
8.8	Internal Grain Transport	288
8.8.1	Auger Housing/Elevators	288
8.8.2	Returns thresher	288
8.8.3	Tank filling auger	289
8.8.4	Grain tank	290
8.8.5	Unloading auger	292
8.8.6	Unloading Auger Clutch	293
8.8.7	Unloading tube	294
8.9	Rotary Separator	295
8.9.1	Adjusting the revolutions	295
8.9.2	Concave setting	296
8.10	Straw hood	297
8.10.1	Alarm switch for straw hood blocked	297
8.10.2	Light in straw hood	298
8.11	Chaff spreader	299
8.11.1	Setting	299
8.12	Maxi Spreader	301
8.12.1	Operation and Adjustment	301
8.12.2	Adjustment of Sensors	302

8.3.2 Cylinder Variator

T006172

(fig. 2)

The threshing cylinder is driven from the rear beater shaft through the hydraulic variator pulley (1) and the spring-loaded variator pulley (2).

The peripheral speed of the threshing cylinder is variable from 12.8 to 35.5 m/sec. on the terminal from the menu "Cylinder RPM". From the variator pulley (2) the cylinder is driven by a belt drive which is tightened with the spring-loaded tension pulley (4). Do not set the cylinder to run at maximum speed when the machine is cold.

Allow the machine to reach normal working temperature before running the cylinder at max. speed. Otherwise, the pressure in the variator pulleys may rise and damage the seals.

For the harvest of special crops like maize and the like, the threshing cylinder can be geared down to 10 m/sec. by exchanging the belts and the belt pulley (5) on the cylinder shaft.

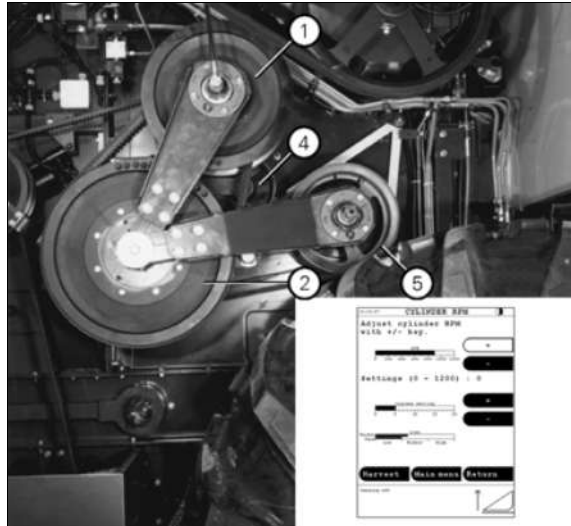

Fig. 2.

I015887



WARNING:

The variator pulleys may be disassembled only by experts who are acquainted with the pulleys, as disassembly in wrong order may cause personal injury. The spring pressure is 400 kg.



8.3.3 Turning Tool for Cylinder

T006171

(fig. 3)

The turning tool positioned in a support on the side of the elevator, can be used for turning the cylinder at adjustments, repairs, cylinder stop, etc.



WARNING:

Having used the cylinder wrench always remove it from the cylinder shaft before starting the machine.



Fig. 3.

I015862

8.6.4 Replacement of Knives

T006176

(fig. 5)

Rotary Knives

To replace or turn the rotary knife (1) dismount the screw (2) and the bushings (3). When replacing single knives pay attention to the weight difference of the knives. Too great difference will cause vibrations. When replacing worn knives, replace them two by two opposite each other to avoid vibrations.

Check and lubricate the knives daily. Damaged or half knives will quickly ruin the straw chopper.

Counter Knives

When the screws (4) and the profile (5) are dismounted, the knives (6) can be replaced by pulling them out of the attachment (7).



WARNING:

Always wear gloves when exchanging knives.

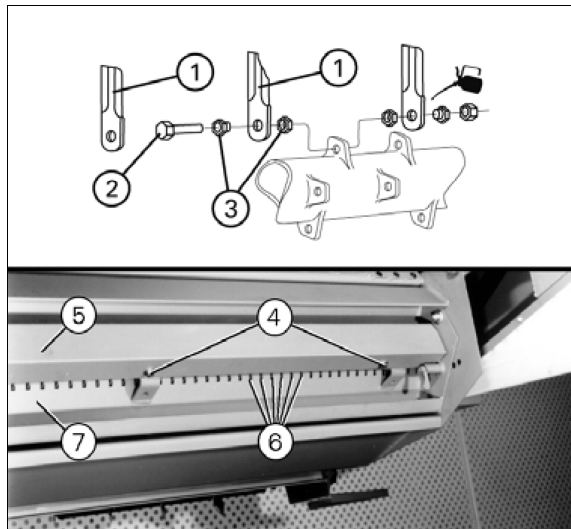

Fig. 5.

I015863

Access to Grain Tank

An access ladder (1) to the engine compartment is provided behind the rear panel (2) on the right-hand side of the machine. It can be lifted off and used for instance when cleaning the machine. The rear panel has to be opened at the lock (3) using the supplied key, before the engine compartment can be accessed as a safety barrier prevents access when the panel is closed. The ladder serves as an access ladder, the fifth step being secured in the bottom brackets (4).



WARNING:

When the rear panel (2) is open it must be prevented from being slammed shut by accident, for instance in windy weather.



WARNING:

Before stepping onto the access ladder to the engine compartment make sure the fifth step of the ladder rests securely on the bottom brackets.

For further information see §3.8.2, page 64.

The grain tank may be accessed only through the service door while the grain tank covers are closed (middle picture fig. 6). The service door is reached from the engine hood (4) stepping only on the permitted tread areas, the handrail (5) being raised.

The service door is opened by turning the lock (6) and folding the door (7) aside. When leaving the grain tank close the service door and make sure a sharp click is heard when it locks.

Use the handle (8) when operating the handrail. It is important to make sure that the handrail is secured, before stepping onto the engine hood.

IMPORTANT: Always put down the handrail before leaving the engine compartment.



WARNING:

Never enter the grain tank without stopping the engine, removing the ignition key and switching off the main switch, to prevent other persons from starting the bottom auger unintentionally.



WARNING:

Before stepping onto the engine hood make sure there are no live overhead power lines above the machine.

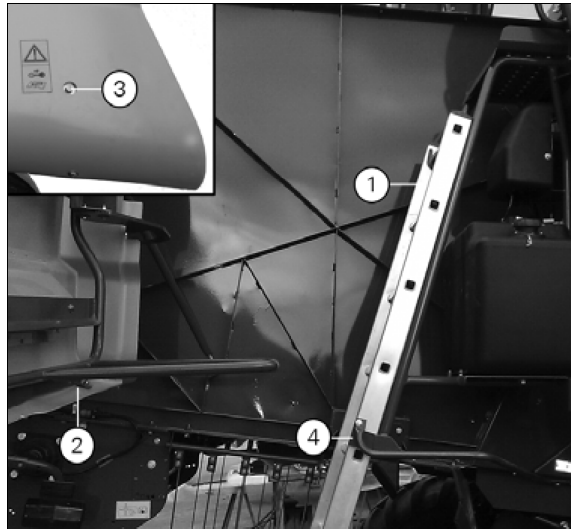

I016587



I015874



Fig. 6.

I036864

8.12 Maxi Spreader

8.12.1 Operation and Adjustment

T007341

(fig. 1)

A Maxi Spreader can be fitted to the combine to ensure optimum spreading of the chopped straw leaving the chopper. The material is accelerated by two rotating spreading discs (1) and (2) and distributed over the full cutting width. A discharge splitter (3) located between the two spreading discs is oscillating from side to side ensuring an even spread of the material.

NOTE: The hydraulic couplings of the Maxi Spreader must always be connected to the motors. If the hoses are not connected to each other or to the motors, the oil will have to pass through the pressure control valve resulting in heating of the oil.

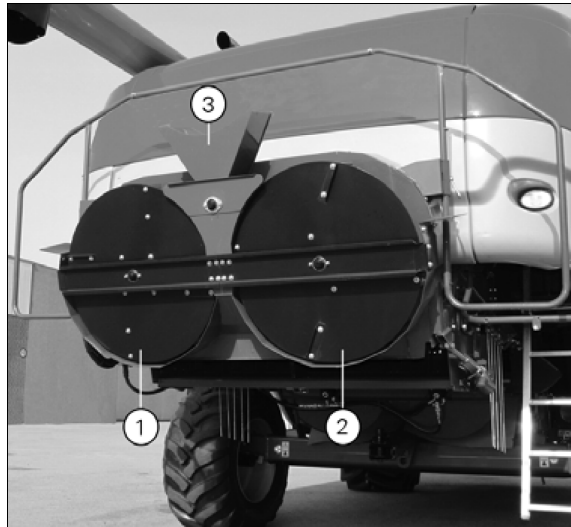

Fig. 1.

I021171

Operation

(fig. 2)

The Maxi Spreader is operated from the cab through the cabin box from which it is possible to adjust the speed of the spreading discs and compensate of any side winds.

NOTE: It takes approx. 10 seconds for the spreading discs to reach the new speed.

Adjustment of spreading width: The speed of the spreading discs and consequently the spreading width is adjusted using the button (1). The higher the speed, the larger the spreading width.

Compensating for side winds: To compensate for side winds use the button (2) in the following way:

- With side winds coming from the left, turn the button to the left (this increases the speed of the left-hand spreading disc and reduces the speed of the right-hand spreading disc).
- The button must be in the middle position when there is no side wind (same speed on both spreading discs).
- With side winds from the right, turn the button to the right (this increases the speed of the right-hand spreading disc and reduces the speed of the left-hand spreading disc).

Speed alarm for spreading discs (3) (also acoustic signal).

On/Off LED (4)

NOTE: The spreading discs start rotating as soon as the threshing unit is engaged.

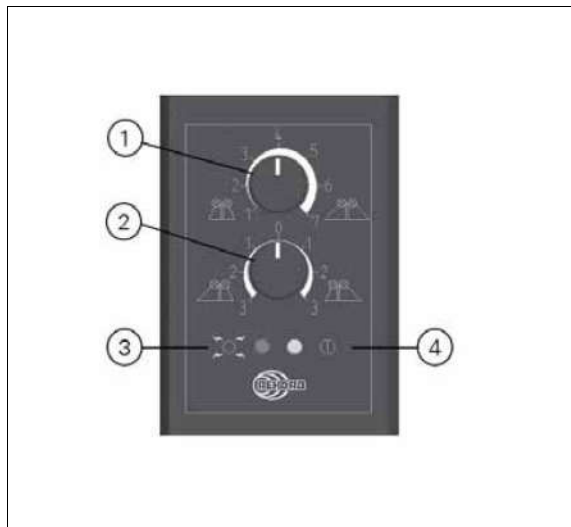

Fig. 2.

I020293

8.15 Threshing

8.15.1 Threshing directions

T005742

To fully utilize combine capacity when direct cutting or threshing swathed crops, an even feed is vital.

Uneven feed causes uneven loading of the threshing unit, which cannot be compensated for by adjusting the machine.

Uneven feed is caused by wrong use or adjustment of reel, feathering fingers, table auger, cut-off strips or elevator chain.



Adjust the machine in accordance with the chart "Initial Harvest Settings" for the crop to be threshed.

Do not thresh the material too aggressively, which will crush the straw and make it difficult to separate the grains from the straw. The shaker shoe will be loaded with material, which will make cleaning difficult and reduce capacity.

If threshing is too weak, grains will stick to the straw and the cleaned sample will contain unthreshed ears.

In certain barley and wheat crops it may be necessary to fit 1 or 2 concave filler plates in the front part of the concave. The filler plates prevent half ears and unthreshed grains from passing through the concave at a too early stage.

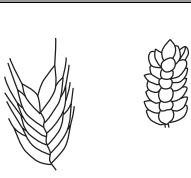
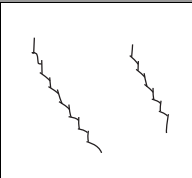
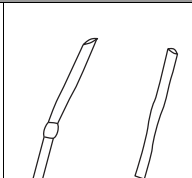
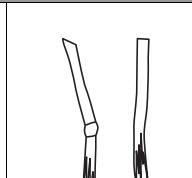
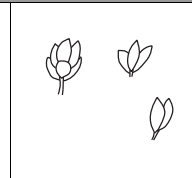
If the sieves are blanked-off to avoid this, capacity may be reduced and the returns volume increased.

Examples of Impurities in the Finished Sample					
					
Half ears	Straw to which grains have stuck	Straw cut twice	Straw cut and torn apart	Grains sticking together	Loose wheat husks

8

Causes of impurities in the finished sample
There is a number of different causes of impurities in the cleaned sample.
Unthreshed ears Sieves opened too much, concave clearance too large.
Short straw/ears Too many ears in the returns system, insufficient air supply from fanning mill.
Straw cut twice Table inclined, the stubble is cut in the left-hand side of the table.
Straw torn apart Too aggressive threshing.
Grains sticking together Sieves opened too much, threshing too weak, loose grains and ears falling unthreshed through the concave.
Chaff and husks Insufficient air supply from fanning mill, too aggressive threshing (all husks are threshed from the straw in wheat).
Long straw Rear beater curtain set too low, the material cannot easily pass onto the straw walkers. Straw walker belt too slack.

9.3.6 Shaker Shoe and Chaff Spreader Counter Drive, and Straw Walker Drive

T006250

(fig. 7)

Belt Drive No. 9, 10, 11, 12

Shaker shoe, straw walkers and chaff spreader are driven by the counter drive pulley (1) which is driven from the rear beater shaft (2) by the belt (3).

The belt for the counter drive (3) is adjusted with the tension pulley (4).

The belt for the shaker shoe drive (5) is adjusted with the tension pulley (6).

The belt for the straw walker drive (7) is adjusted with the tension pulleys (8) and (11). The spring (12) is adjusted with the nut (13) at a length of approx. 106 mm. If the clearance between the belts (14) gets below 61 mm, the tension pulley (11) must be adjusted downward using the nut (15) to restore the measure 61-65 mm at (14). If the clearance exceeds 65 mm, the tension pulley (11) must be adjusted downward until the measure 61-65 mm at (14) is restored. Adjust the spring length (12) at 104-108 mm using the nut (13) and tighten the counternut (16). Tighten the bolt (17) and the counternut (18).

NOTE: It is important that the straw walker drive is correctly adjusted as the belts apart from driving the straw walkers, function as slip clutch. Too tight belts may cause damage to the straw walkers in case of blocking.

To adjust the belt for the chaff spreader hydraulic pump (9) move the hydraulic pump (10) up or down.

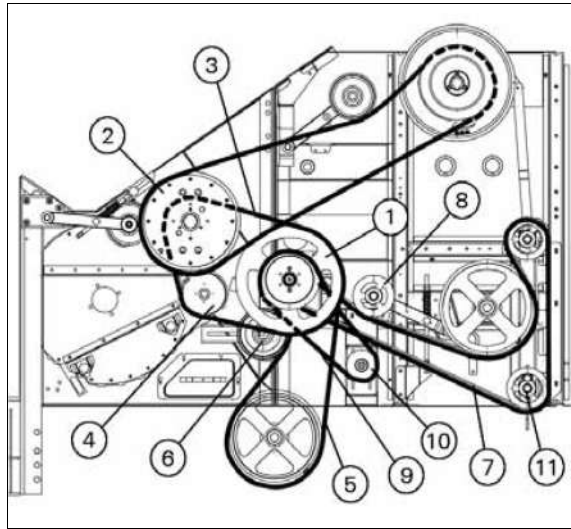

I016884

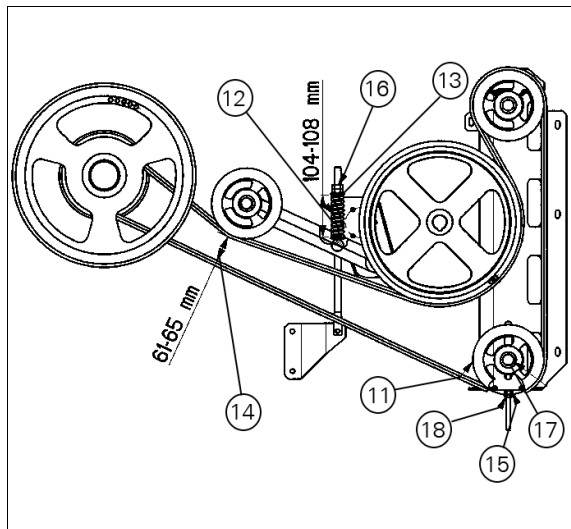

Fig. 7.

I016885

10. Hydraulics

10.1 Safety precautions	333
10.1.1 Safety Precautions, Hydraulic System	333
10.2 Hydraulic System	334
10.2.1 Hydraulic system, standard combine	334
10.2.2 Hydraulic System, Four-Wheel Drive	335
10.3 Oil change	336
10.3.1 Draining and refilling hydraulic oil	336
10.4 Filter Change	337
10.4.1 Filter change in general	337
10.4.2 Return Oil Filter	337
10.4.3 Storage of Hydraulic System	338
10.5 Auxiliary Hydraulics	339
10.5.1 Auxiliary hydraulics in general	339
10.5.2 Functions and Auxiliary Hydraulics	339
10.5.3 Reel adjustment fore/aft - up/down	339
10.6 Hydraulic diagrams	340
10.6.1 Hydraulics Diagram, Standard Combine	340
10.6.2 Hydraulics Diagram, Auto Level Combine	342
10.6.3 Hydraulics Diagram for Chaff Spreader	344
10.6.4 Hydraulics diagram for Maxi Spreader	345

Key to Hydraulics Diagram, Standard Combine			
A	Hydraulic oil tank	I1	Hydraulic accumulator for table suspension
B1	Hydraulic pump	I2	Hydraulic accumulator for table suspension
B2	Hydraulic pump for chaff spreader	I3	Hydraulic accumulator for table suspension
C	Flow divider	I4	Hydraulic accumulator for table levelling
D	Quick-attach coupling / multicoupler	I5	Hydraulic accumulator for table levelling
E1	Hydraulic oil motor for reel	J1	Master cylinder for reel fore/aft
E2	Hydraulic motor for rape auger (optional)	J2	Slave cylinder for reel fore/aft
E3	Hydraulic motor for reversing	K1	Master cylinder for reel up/down
E4	Hydraulic motor for chaff spreader	K2	Slave cylinder for reel up/down
F1	Magnetic valve for reel up/down	L	Hydraulic cylinder for table up/down
F2	Magnetic valve for reel fore/aft	M1	Hydraulic cylinder for steering
F3	Magnetic valve for table up/down	M2	Hydraulic cylinder for steering
F4	Magnetic valve for table up/down	N	Hydraulic oil filter in hydraulic tank
F5	Magnetic valve for cylinder variator	O	Hydraulic oil filter on hydrostatic pump
F6	Magnetic valve for unloading auger out/in	P	Main valve with pressure control valve
F7	Non-return valve for reel fore/aft	S1	Cylinder variator
F11	Magnetic valve for table levelling	T	Hydraulic cylinder for unloading auger out/in
F13	Non-return valve for unloading auger out/in	U	Hydrostatic pump
F16	Non-return valve for table levelling	V	Hydrostatic motor
F17	Magnetic valve for gearshift	W1	Hydraulic cylinder for gearshift
F18	Magnetic valve for gearshift	W2	Hydraulic cylinder for gearshift
F19	Magnetic valve for gearshift	W3	Hydraulic cylinder for gearshift
F20	Magnetic valve for reversing motor	W4	Hydraulic cylinder for parking brake
F22	Magnetic valve for parking brake	X1	Oil cooler for transmission
G	Orbitrol steering valve	X2	Oil cooler for auxiliary hydraulics
H3	Hydraulic cylinder for table levelling		

10

8370 P - 8400 P Max. 2080 rpm	Auxiliary Hydraulics System Pump Part I	Reel System Pump Part II	Steering System Pump Part III
Oil flow	68 l/min.	28 l/min	21 l/min.
Pressure	175+/-5 bar	125+/-5 bar	160+/-10 bar

11.2 Undercarriage

11.2.1 Undercarriage in general

T005754

1. Traction wheels
2. Rear wheels
3. Table trailer jockey wheel
4. Table trailer wheels

Retighten the traction wheels before first using the machine. Check the torques frequently, and re-tighten regularly.

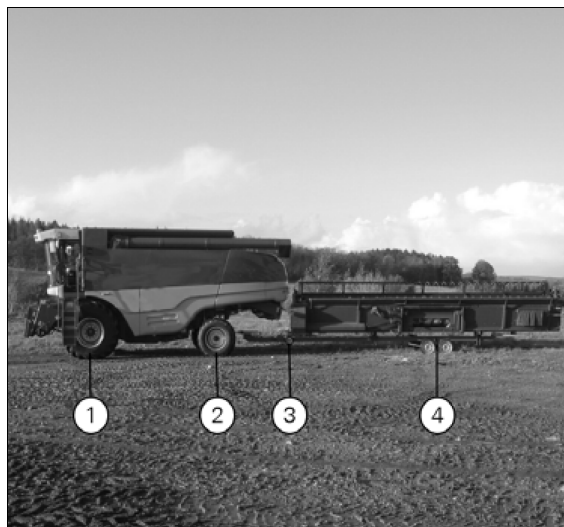

Fig. 1.

I016916

11.2.2 Wheel nut torques

T006305

(fig. 2)

8370 P (dry threads)	
Traction wheels	70 kpm/700 Nm

8370 P-8400 P (dry threads)	
Rear wheels	35 kpm/350 Nm

8370 P-8400 P (oiled threads)	
Traction wheels	80 kpm/800 Nm

Table trailer wheels	15 kpm/150 Nm
----------------------	---------------

Check air pressure in tyres before first using the machine, and then check regularly.

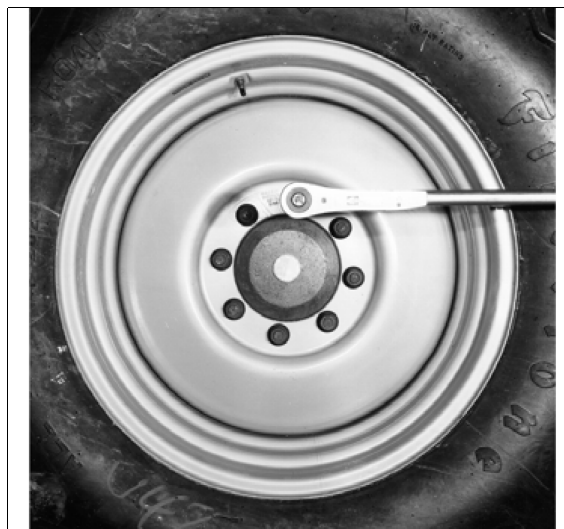

Fig. 2.

I016919

11.2.3 Tyre pressure

T005755

NOTE: Use only the tyres listed in the chart below or in the technical specifications of the combine.

Model	Tyre size	Make	Rim	Pressure, bar
Traction wheels				
8370 P	650/75 R32	CONTINENTAL	DW21Ax32	4.1
	680/85 R32	CONTINENTAL	DW21Ax32	3.2
	800/65 R32	GOODYEAR	DW27Ax32	2.0
	900/55 R32	GOODYEAR	DW27Ax32	1.9
	900/60 R32	MICHELIN	DW27Ax32	2.0

Bearings for reel suspension (7)

Qty: 1
 Colour: Yellow
 Interval: 100 Hours
 Lubricant: Grease



Fig. 10. I019386

Spring actuating rod, drive shaft for cutting table / transmission shaft, cutting table (8)

Qty: 4 / 1
 Colour: Blue
 Interval: 50 Hours
 Lubricant: Grease

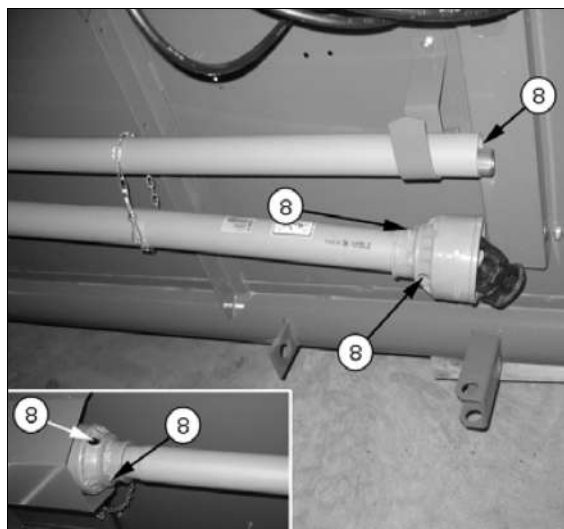

Fig. 11. I019387

Crop elevator chain (9)

Qty: 4
 Colour: Blue
 Interval: 50 Hours
 Lubricant: Oil
 Notes: The chain must be slackened during lubrication to make sure that the oil penetrates into the chain links.

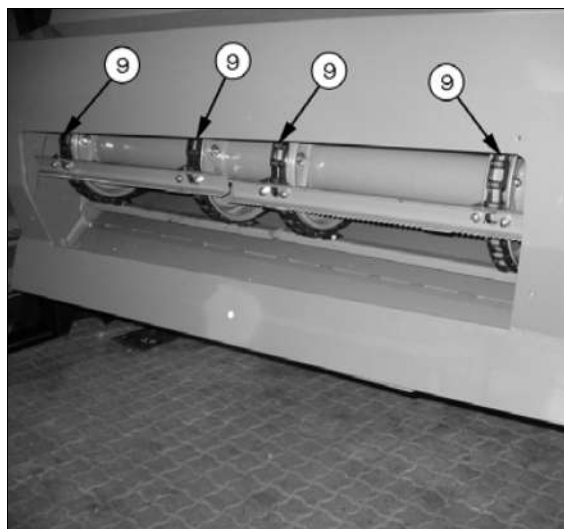

Fig. 12. I019388

Bearing for final drive shaft, Auto Level machines (60)

Qty: 1

Colour: Blue

Interval: 50 Hours

Lubricant: Grease

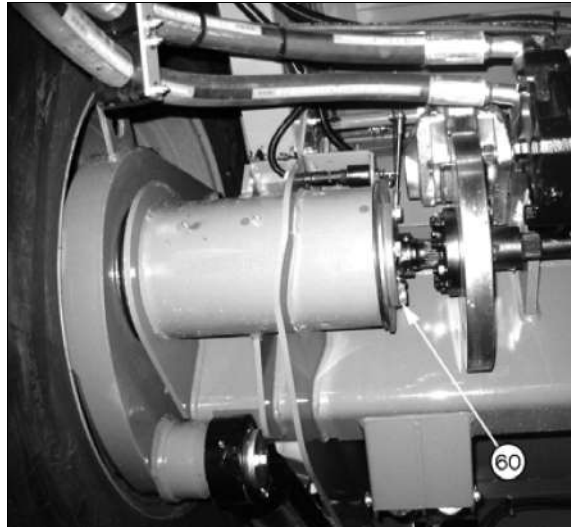

Fig. 40.

I019416

Tension pulley for hydrostatic pump (62)

Qty: 1

Colour: Yellow

Interval: 100 Hours

Lubricant: Grease



Fig. 41.

I019417

Knife drive gearbox (69)

Qty: 1

Colour: Blue

Interval: 50 Hours

Lubricant: Grease

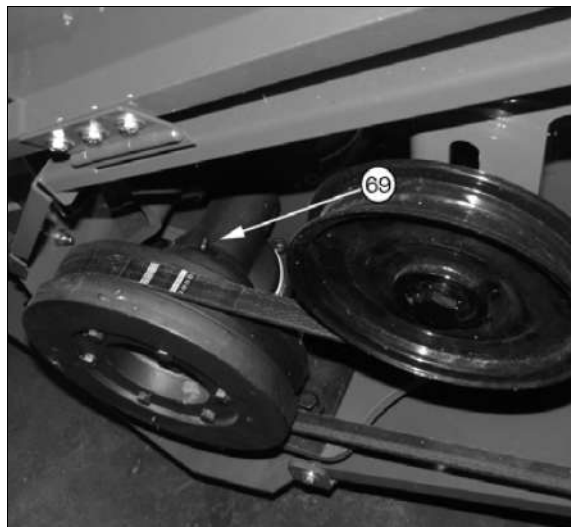

Fig. 42.

I019418

Bearings for swivel traction wheel suspension, Auto Level (58)

Qty: 2

Colour: Blue

Interval: 50 Hours

Lubricant: Grease



Fig. 70.

I019372

Ball joint for levelling ram, AL table (59)

Qty: 1

Colour: White

Interval: 250 Hours

Lubricant: Grease



Fig. 71.

I019373

Bearing for final drive shaft, standard machines (60)

Qty: 1

Colour: Blue

Interval: 50 Hours

Lubricant: Grease

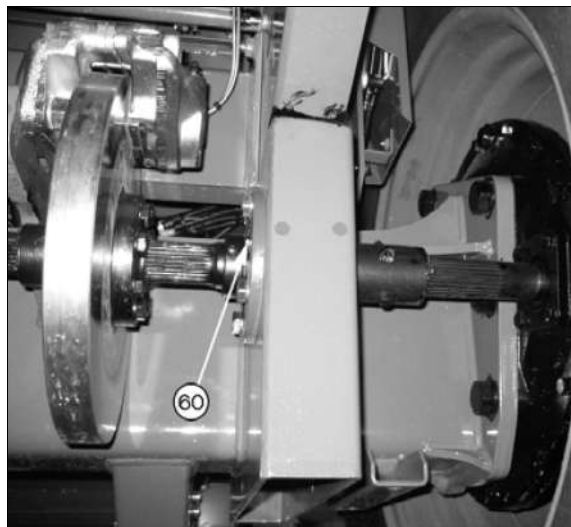

Fig. 72.

I019374

11.5 Climate control

11.5.1 Diagram for Climate Control System

T005772

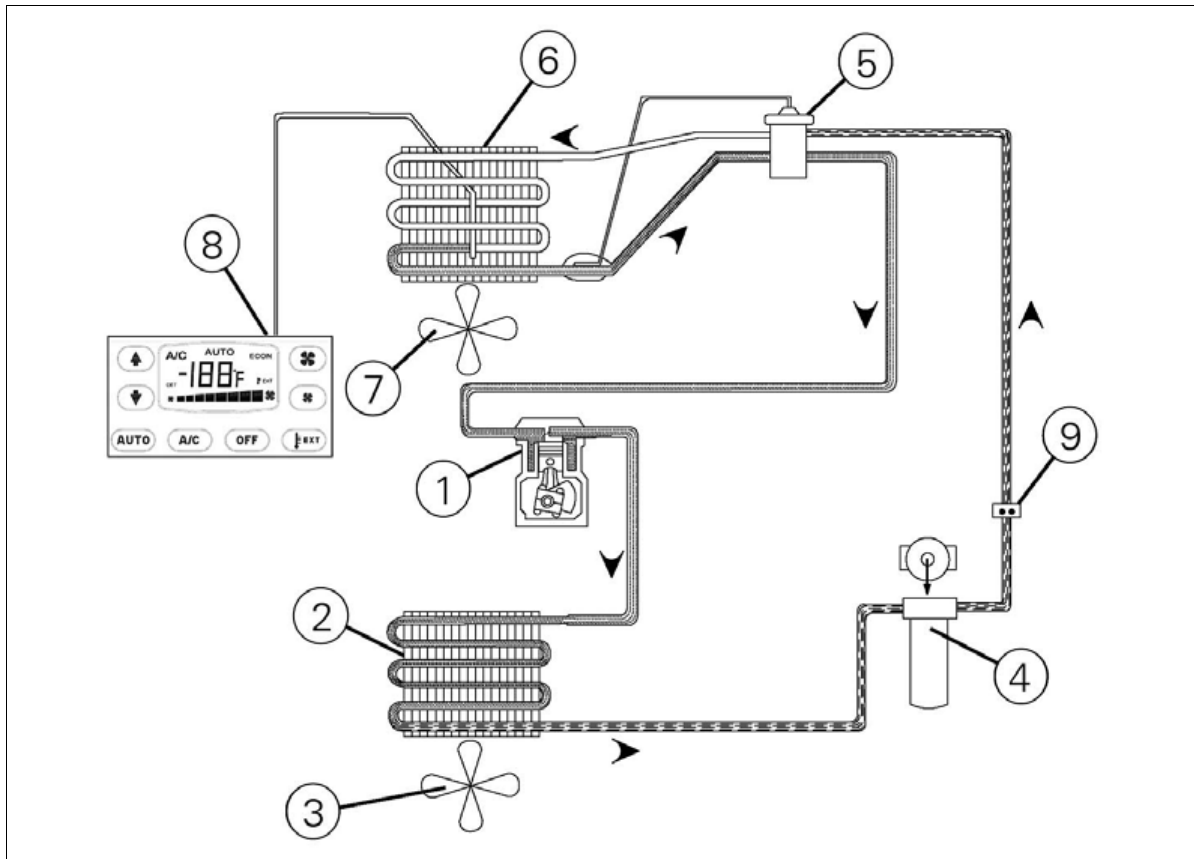

Fig. 1.

I016906

- | | |
|-------------------------------|---------------------------|
| 1. Compressor | 6. Cooling element in cab |
| 2. Condenser | 7. Blower in cab |
| 3. Fan blade on diesel engine | 8. Temperature control |
| 4. Filter and sight glass | 9. High/low pressostat |
| 5. Expansion valve | |

11

11.5.2 Maintenance

T006310

(fig. 1)

Daily

Check V-belt for compressor (1).

Weekly

Clean condenser (2).

Check sight glass in filter (4):

A: If the glass is white when the compressor is running, the climate control system is low on refrigerant.

B: Only change the filter if the climate control system has been opened or drained of refrigerant.

Yearly

Consult dealer for air-conditioning overhaul.



WARNING:

Smoking and naked flames should be avoided during servicing owing to the risk of refrigerant leaks.

If ignited, the gas gives off toxic fumes.

12.2.2 Electric Boxes and Main Switch

T006318

(fig. 2)

Each function of the electrical system has its own relays and fuses, and all external wires are sheathed.

The relays and fuses for the cab are grouped in the cab floor.

The relays and fuses of all other functions are fitted centrally in the electric box (1) on the left-hand side of the machine next to the job computers (2) for FIELDSTAR.

All relays and fuses are marked on the rail (3) to help identify the function of the relay and the rating of the fuse.

All wires are marked with a number on both ends, and are grouped according to colour.

The circuit between battery and electrical system is switched on and off with the main switch (4) located under the electric box.

Remove the main switch handle when leaving the machine.

During off-season storage, etc. the ignition key must be turned in position 0, the main switch must be switched off and the main switch handle (4) must be removed. If the electrical system is switched on for a long time under wet conditions it may corrode. Detach the terminals from the starter battery. It is advisable to store the battery in a frost-free room and keep it charged.

The box on the left (5) is suitable for storage. Do not store fluids, wet or heavy items (max. 15 kg) in the box.



WARNING:

Always remove ignition key and main switch handle before carrying out any delivery check and service on the machine.

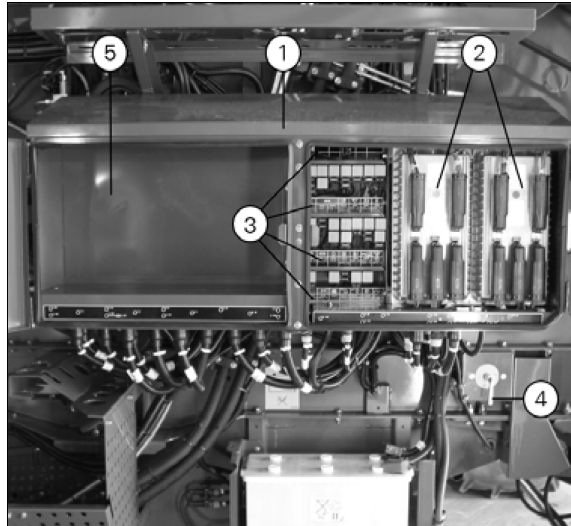

Fig. 2.

I016928

Fuse	Rating	Function	Diagram
F05	25.0 A.	HVAC	100-7
F06	7.5 A.	HVAC	100-7
F07	7.5 A.	HVAC	100-7
F08	5.0 A.	Terminal and printer	050-4
F09	5.0 A.	Rearview mirror and radio	100-6
F10	5.0 A.	Direction indicator	060-4
F11	5.0 A.	Direction indicator	060-4
F12	10.0 A.	Work light 2	070-4
F13	30.0 A.	Work light 1, front RH	070-4
F14	30.0 A.	Work light 1, front LH	070-4
F15	10.0 A.	Rotating yellow beacon, cab roof	070-4
F16	20.0 A.	Windscreen wiper	100-7
F17	15.0 A.	Seat and lighter	100-7
F18	10.0 A.	Auto-Steering	110-1
F19	10.0 A.	Auto-Steering	110-1
F20	15.0 A.	Cab 12V, cool box	100-7
F21	25.0 A.	Electric box, LH side	026-1
F22	20.0 A.	Maxi Spreader	120-3
F23	10.0 A.	Maxi Spreader	120-3
F24	10.0 A.	NO _x sensors	026-1
F25	3.0 A.	12V engine	026-1
F26	15.0 A.	DENOX supply module	026-1
HOS			
HOS18	25.0 A.	Bottom auger cover plate	090-6
ILS			
ILS03	7.5 A.	Rotating yellow beacon, straw hood	070-4
ILS04	10.0 A.	External 12V connectors	010-4
ILS07	5.0 A.	Light, grain tank	070-4
ILS08	5.0 A.	Light, straw hood	070-4

12

12.6.4 Components

T005908

Component	Description	Diagram
1100	DC/DC	080-5
AKK1	Battery	010-4
B1	AdBlue tank sensor	026-1
B3	Sensor, exhaust temperature 1	026-1
B4	Sensor, exhaust temperature 2	026-1
B5	Dosing module	026-1
B6	Sensor, ambient temperature	026-1
B7	NO _x sensor	026-1
B8	NO _x sensor	026-1
CAP	Auto Level / electrical sieve computer	050-4
CLP	Job computer LH	050-4
CRP	Job computer RH	050-4

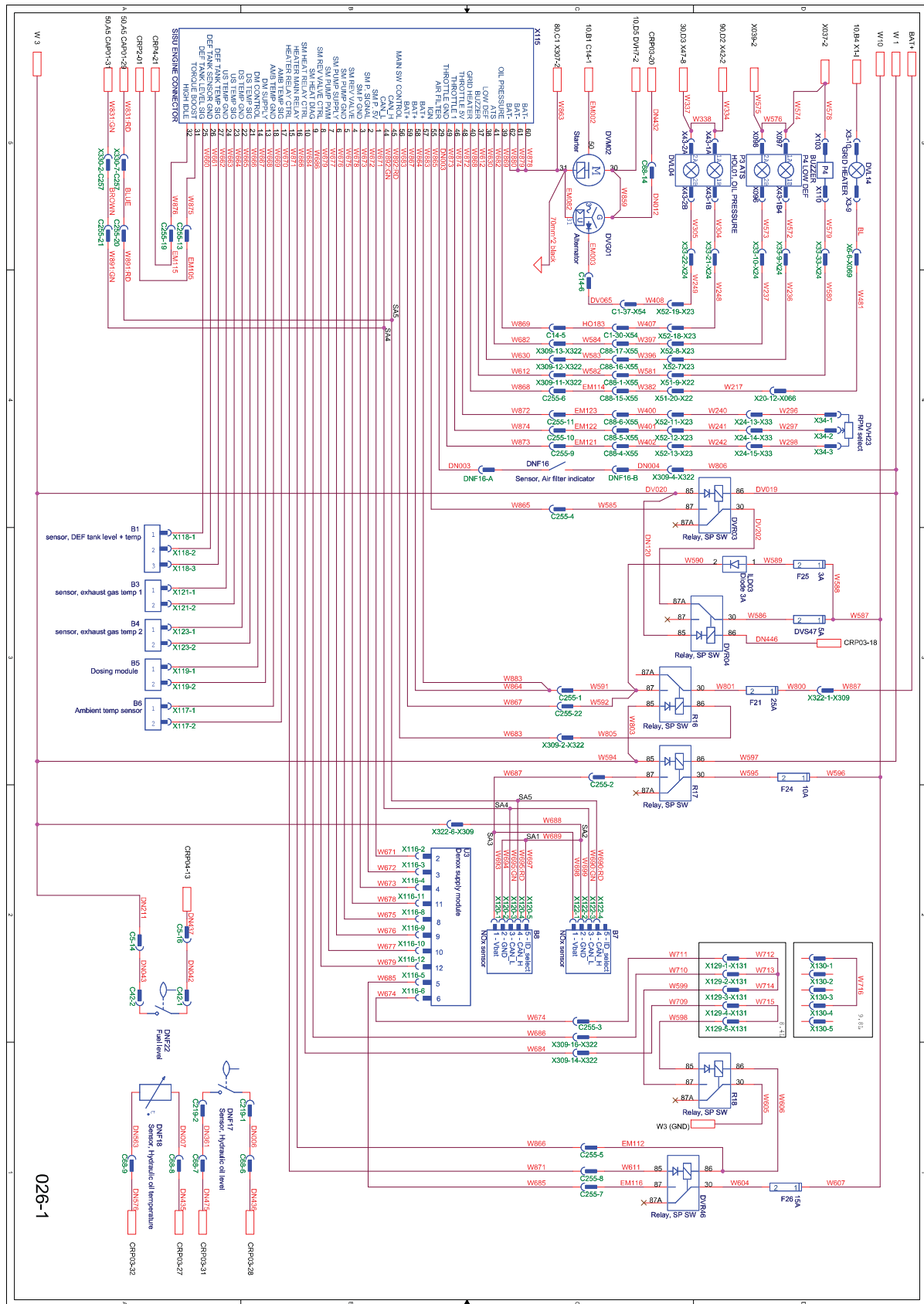

Fig. 3. 026-1 Engine installation

1030813

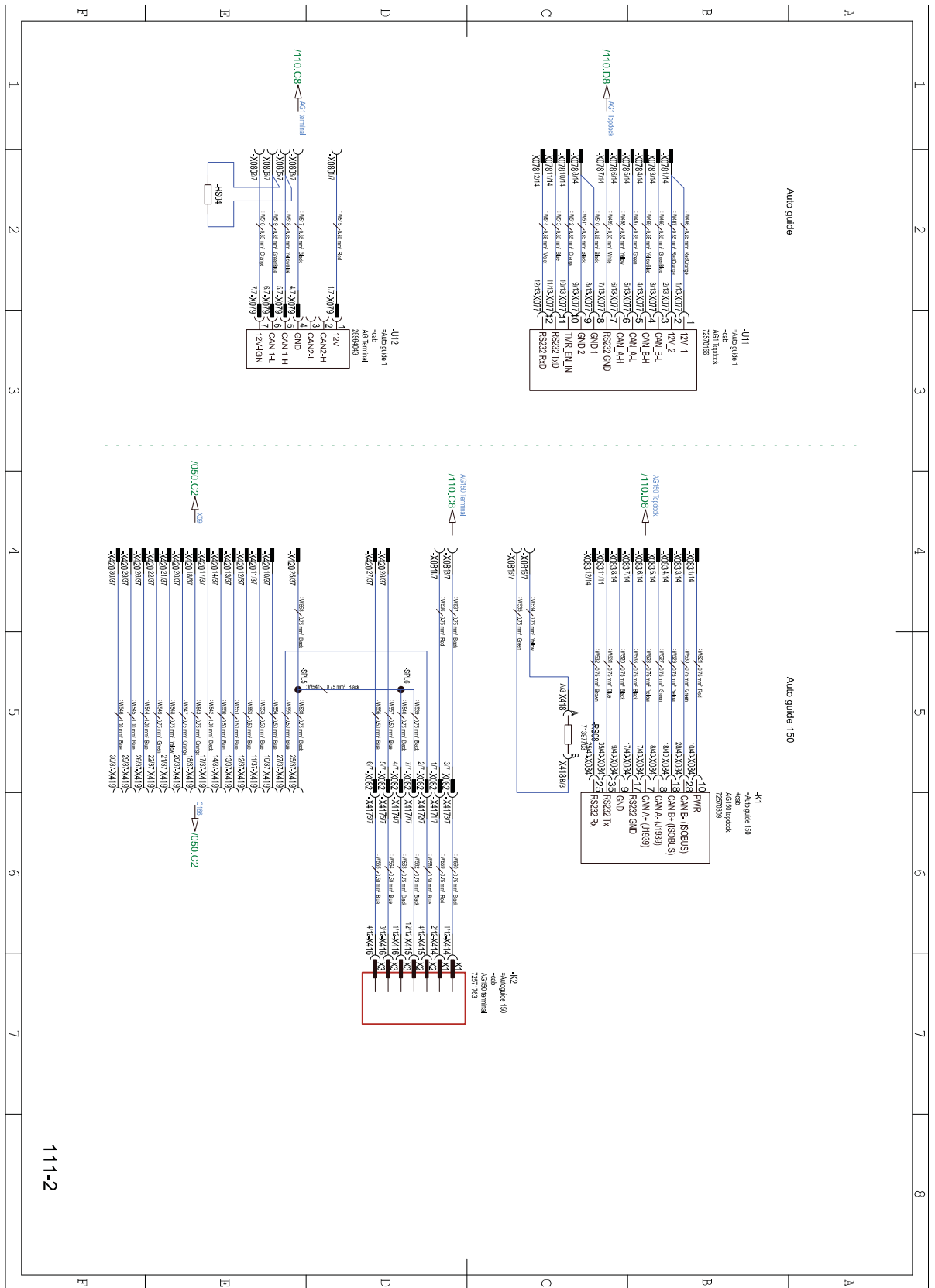

Fig. 13. 111-2 Auto-Steering

1030815

A

Accessibility	
Cab	64
Engine compartment	64
Grain tank	291
Accumulated Machine Data	99
AdBlue	209
Adjustable armrest	55
Adjustment of	
Chaff spreader	299
Clock	121
Concave	129
Cylinder speed	129
Electrical sieve	129
Electrical straw deflectors	134
Fanning mill revolutions	129
Maxi Spreader	301
Operator seat	59
Sieve extension	129
Steering column	57
AGCO service	14
Air cleaner	199
Air-intake	199
Air-suspended seat	59
Alarms	
Engine monitoring/alarm	96
Engine Safety Alarm	96
Grain tank cover	134
Alternator	326
Appropriate Use	13
Area Measuring	121
Armrest	55
Auger extensions	244
Auger housing	288
Auto Level	
Auto Level combine	180
Levelling errors	190
Auto Level Combine	180
Auto Level combine	
Auto Level	177
Calibration	184
Calibration errors	185
Combinations	177
Diagnosis	193
Hydraulic cylinders	181
Manual control	180
Operation of	177
Safety system	187
Transport	182
Auto Level Combine/Table	
Combinations	177
Levelling errors	190
Troubleshooting	189
Use	177
Auto Level Table	160
Coding	162, 186
Principle	160
Auto Level table	268
Assembly	176
Bleeding of	161
Manual control	165
Normal operation	164
Turns	165
Automatic Table Control	265
Auto-Steering	78
Auxiliary Hydraulics	339

CLICK HERE TO **DOWNLOAD** THE COMPLETE MANUAL

- Thank you very much for reading the preview of the manual.
- You can download the complete manual from: www.heydownloads.com by clicking the link below



- Please note: If there is no response to CLICKING the link, please download this PDF first and then click on it.

CLICK HERE TO **DOWNLOAD** THE COMPLETE MANUAL