

IDEAL Series Combine

IDEAL 7

IDEAL 7PL

IDEAL 7T

IDEAL 8

IDEAL 8PL

IDEAL 8T

IDEAL 9

IDEAL 9PL

IDEAL 9T



Breganze

AGCO S.p.A. - Via F. Laverda, 15/17 - 36042
BREGANZE (VI) – Italy.

FENDT is a worldwide brand of AGCO

© AGCO 2019

Original Operator's Manual

September 2019

79037468B

EME

English

CLICK HERE TO **DOWNLOAD** THE COMPLETE MANUAL

- Thank you very much for reading the preview of the manual.
- You can download the complete manual from: www.heydownloads.com by clicking the link below



- Please note: If there is no response to CLICKING the link, please download this PDF first and then click on it.

CLICK HERE TO **DOWNLOAD** THE COMPLETE MANUAL

1.5 Operation

1.5.1 Prepare for operation

- Read and understand all the instructions in this manual before you operate, or do maintenance on the machine.
- Make sure that you know the positions and operations of all the controls.
- Make sure that all controls are in the neutral position and that you engage the parking brake before you start the machine.
- Make sure that no personnel are in the dangerous areas at all times. Stop the machine if it is necessary.
- Know the dimensions of the machine and have sufficient available space for its operation.
- If you operate the machine in these conditions, it increases the risk of injury to personnel and damage to the machine:
 - At high speeds
 - Around personnel
 - Near buildings
 - Near other equipment or possible blockages.
- Do not let children in or near the machine.
- Do not let persons who are not approved operate the machine.
- Do not let other personnel in, or on the machine when in operation.
- Make sure that the machine is in the correct serviceable condition.
- Obey all local laws. Make sure that the machine has the correct equipment in, or on it.
- All equipment has a limit, make sure that you know the:
 - Speed limits of the machine
 - Distances and limits for the brakes
 - Steering sensitivity
 - Steering limits
 - Machine limits when on a slope
 - Load limits.

1.5.2 General information

When the machine is in operation:

- Make sure that you set the machine components to the correct position when you operate on a slope.
- Do not get out of the machine when it is moving.
- Know the dimensions of the machine and make sure that sufficient space is available to let the machine operate.
- Some of the devices on the machine can make it not stable. Be careful when you engage these devices and operate the machine.
- Keep the header as close to the ground as possible while you go down a slope.
- If it is necessary, put on sufficient weight to balance the machine.
- Do not do sudden movements of the controls when the machine is at high speed or cornering.

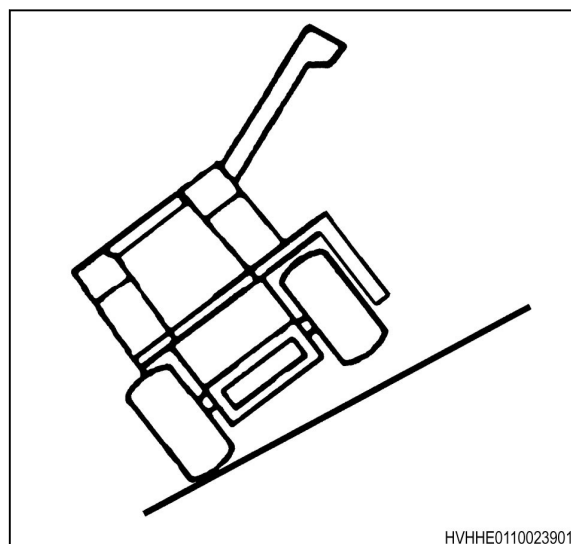

Fig. 4

HVHHE0110023901

1.7.7 Battery safety

- Before you disconnect the battery, set the ignition to OFF, wait 2 minutes then disconnect the battery.
- Make sure that you put on the correct personal protective equipment when you do work or maintenance on batteries.
- Lead acid batteries release hydrogen fumes when charging. The fumes from the batteries are very flammable. Keep open flames and electrical sparks away from the batteries. Charge the batteries in an area with good airflow.
- Metal tools or objects cause a short circuit the battery if they touch the positive and negative connections at the same time.
- If you connect booster cables or charging equipment incorrectly, it causes damage to the battery and electrical components. Always connect the positive cable to the positive battery connector, and the negative cable to the negative battery connection.
- The battery contains lead and acid. Put on personal protective clothing when you do work on a battery.
- If battery fluid touches your skin, flush the area immediately with large quantities of water.
- If battery fluid goes in your eyes, flush with water for a minimum of 15 minutes and get medical aid immediately.
- If you swallow battery fluid, drink large quantities of water. Do not try to vomit. Get medical aid immediately.
- Do not connect 24 V equipment to the machine.
- If you tilt or turn a battery fluid spills. Keep the battery with the connections up.
- Always connect the cable to the negative side of the battery first.
- Always disconnect the cable from the negative side of the battery first.

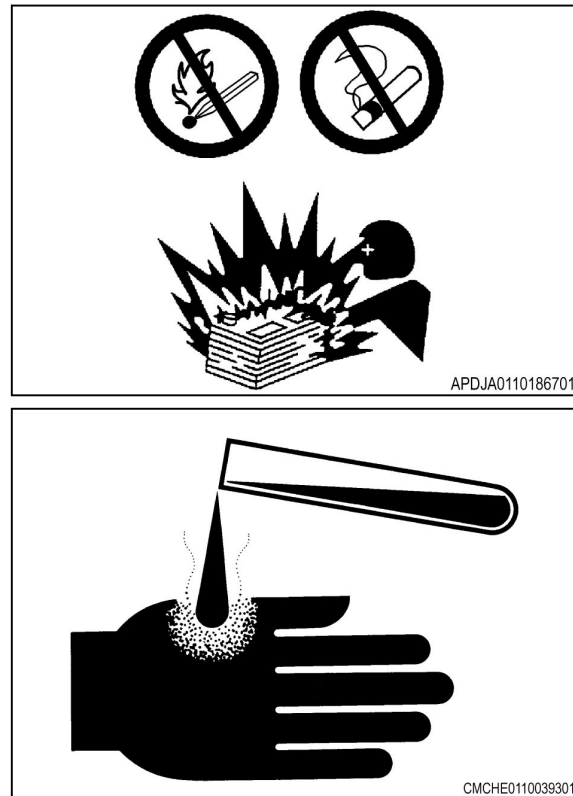

Fig. 22

Number	Decal	Description
24		Negative terminal This is the location of a negative terminal for the electrical system.
25		12 V electrical system The machine has a 12 V electrical system. Do not start the machine with a 24 V power supply, injury or death can occur.
26		Primary switch The location of the primary switch to set all the electrical circuits on the machine to OFF.
27		Before you disconnect the battery 1. Stop the machine. 2. Wait for a minimum of 2 minutes. 3. Set the primary switch to OFF.
28		Primary circuit fuses This shows the configuration and capacity of the primary circuit fuses.
29		Entanglement hazard, rotating auger Do not reach or go into the grain tank when the engine is operating.
30		Hot surfaces, burn hazard Keep a safe distance from hot surfaces.
31		Telescopic handrail Lift the telescopic handrail into the correct position before you do the work and maintenance on the top of the machine.

- Antifreeze
- Tuning
- Belts and chains
- Clutch and brake adjustments.

Changing region

Only the AGCO dealer from where the machine was supplied is liable for the protection given by the warranty. All repairs must be done by this dealer where possible.

If the machine has been moved to a new location far away from the supply AGCO dealer, you must arrange to move the warranty to the local AGCO dealer in the new location.

If you do not arrange the warranty move, this will cause repair charges by the new dealer, unless you can show them the warranty has not expired.

Servicing in warranty

During the warranty period, all servicing and repair work must be done by your AGCO dealer. Your AGCO dealer have experienced technical personnel who will do all servicing and repairs. This will ensure machine performance and efficiency.

Servicing after warranty

After the warranty has expired, you should continue to have servicing and repair work done by your AGCO dealer.

Your AGCO dealer have all the technical information, diagnostic equipment, AGCO service center backup and use only AGCO approved parts.

2.1.7 Waste disposal



CAUTION: Damage to the environment.

Risk of damage to the environment if you incorrectly discard waste materials.

Obey the local regulations when you dispose of waste material.

Incorrect disposal of waste fluids and components can cause pollution in the environment. Discard waste fluids and components correctly. Do not discard waste fluids in drains, water or soil.

You must:

- Use correct containers to collect all fluids.
- Collect and recycle the air-conditioning refrigerant.
- Obey the pollution laws.

These waste items can possibly cause environmental damage:

- Oil
- Fuel
- Coolant
- Brake fluid
- Filters
- Batteries and battery chemicals
- Tires
- Refrigerant
- Hydraulic fluid.

Recycling centers and approved dealers use the correct procedures to safely recycle used materials.

2.3.74 Identification plate for the load sensing pump

The identification plate for the load sensing pump.
The load sensing pump is on the DriveCenter.

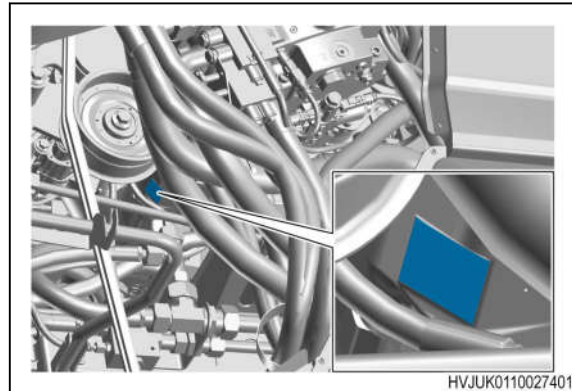

Fig. 15

2.3.75 Hydrostatic motor identification

The identification plate for the hydrostatic motor is
on the left side of the transmission.

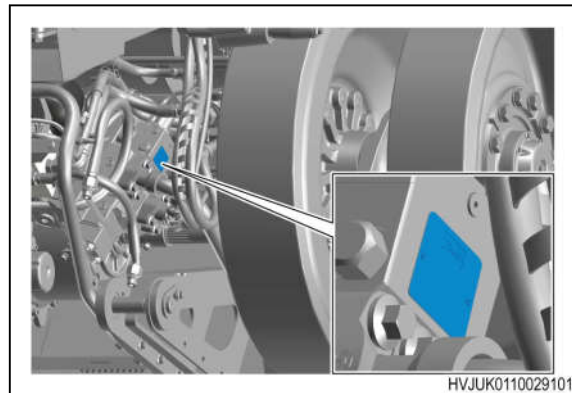

Fig. 16

2.3.76 Ground drive transmission identification

The identification number is put on the front of the
transmission housing.

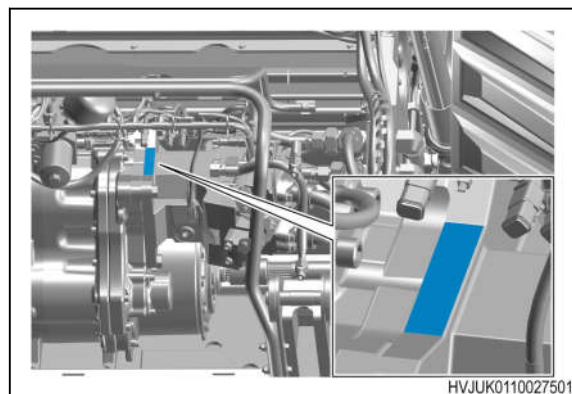

Fig. 17

2.3.77 Trailer hitch identification

There are 2 different trailer hitches available for the machine. The trailer hitch identification plate is on the right side of the trailer hitch.

If your trailer hitch requires maintenance or replacement parts, record the details on the plate and give them to your approved dealer.

DPF soot levels calculated by Electronic Control Unit (ECU)	0	1	2	3	4
Decrease in engine performance ⁽¹⁾	No	No	No	50% torque reduction	25% rpm and 50% torque reduction
Use the operator screen to start the parked regeneration	No if < 250 hours from previous regeneration	Yes	Yes	Yes	Yes
Use diagnostic tool to start the parked regeneration	Yes	Yes	Yes	Yes	Yes

⁽¹⁾ When a decrease in the engine performance occurs, the operation of all the attached equipment stops.

2.6.3 DPF overview

The AGCO Power stage V engines have a DPF that obeys the necessary exhaust emissions levels for stage 5 (Regulation (EU) 2016/1628).

The DPF operates to:

- Limit the mass and the number of poisonous particles that exit the exhaust system.
- Collect and keep the soot until it becomes burned off during a regeneration procedure.

For the DPF to operate correctly it is necessary to do regular regeneration procedures to burn the collected soot.

A DPF regeneration procedure can automatically start and operate during the usual operation of the machine (passive regeneration).

For a better burn, you can manually start a standstill regeneration (active regeneration) with a procedure on the terminal. Always do a standstill regeneration before an oil change.

NOTE:

Approved personnel can also do a standstill regeneration with the specified Electronic Diagnostic Tool (EDT).

NOTE:

You can only do a maximum of 6 standstill regenerations before it becomes necessary to change the engine oil.

The DPF regeneration procedure uses very high temperatures of more than 250 °C.

Do not operate the engine at idle speed or in low load conditions for more than 15 minutes. Operation of the engine at idle speed or in low load conditions does not sufficiently increase the temperature of the exhaust system. Extended periods of engine operation in these conditions can lead to:

- An increase in the number of times that you regenerate the DPF.
- Too much soot collected in the DPF.
- Too much soot in the Exhaust Gas Recirculation (EGR) system.
- A decrease in the power output of the engine.
- Damage to the exhaust aftertreatment components.

2.9 Threshing system

2.9.1 Single Helix rotor

The Single Helix rotor does 4 operations to the crop while it turns:

- Pulls the crop in
- Threshing
- Separation
- Pushes the grain and chaff out.

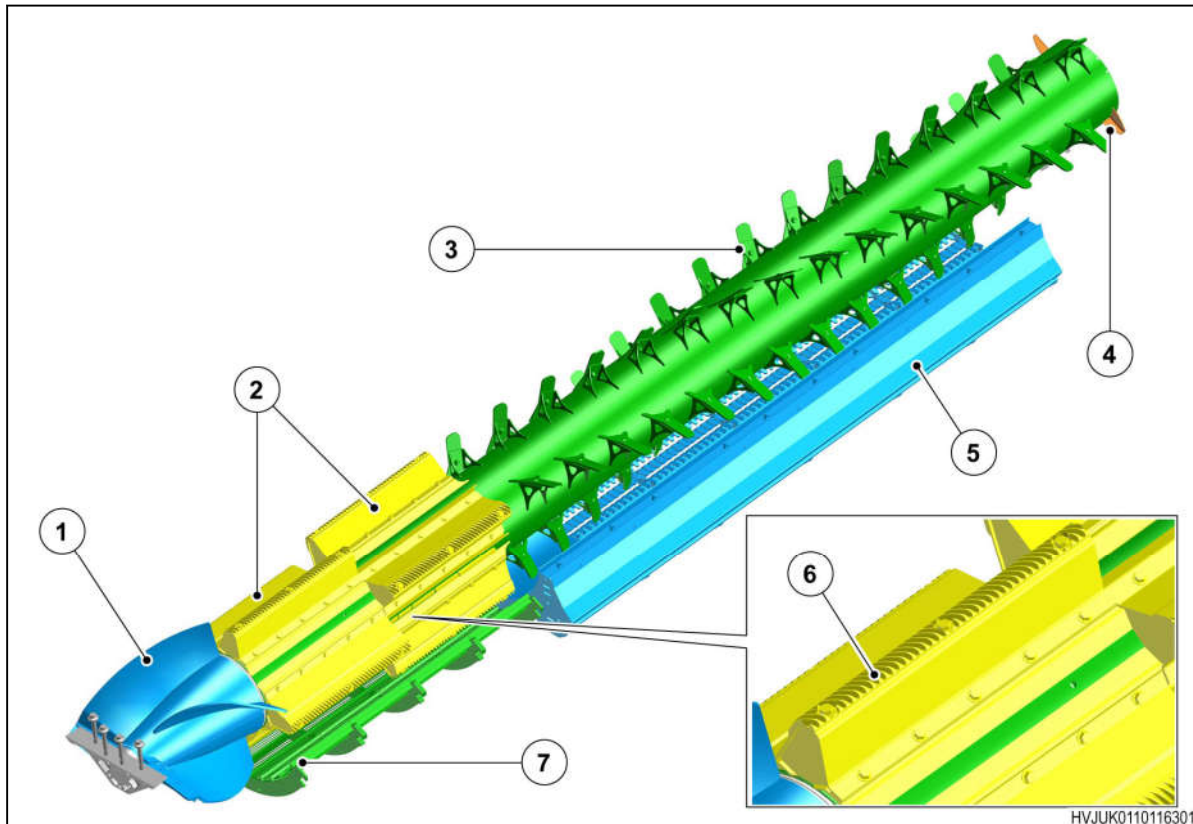

Fig. 33

- | | |
|----------------------|---------------------|
| (1) Flighting | (5) Separator grate |
| (2) Rasp bar support | (6) Rasp bars |
| (3) Fingers | (7) Concave |
| (4) Paddles | |

1. The flighting (1) turns to pull the crop from the RotorFeeder.
2. The flighting moves the crop in a circular direction and along through the separation system.
3. The rasp bars (6) rub the crop against the concave (7) to loosen the grains. This operation does most (approximately 70% to 80%) of the grain separation.
4. The turn force from the rasp bars moves the crop.
5. The fingers (3) move the crop along the separator grate to complete the grain separation task.
 - The crop moves across the separator grate many times.
 - The grain and chaff move through the separator grate.
 - The fingers push the straw that does not go through the separator grate in a rearward direction.
6. The paddles (4) move the straw out of the rotor and in to the straw chopper.

Related Links

[Adjust the rotor deflector on machines with 1 rotor](#) page 389

2.12.3 Tank filling auger

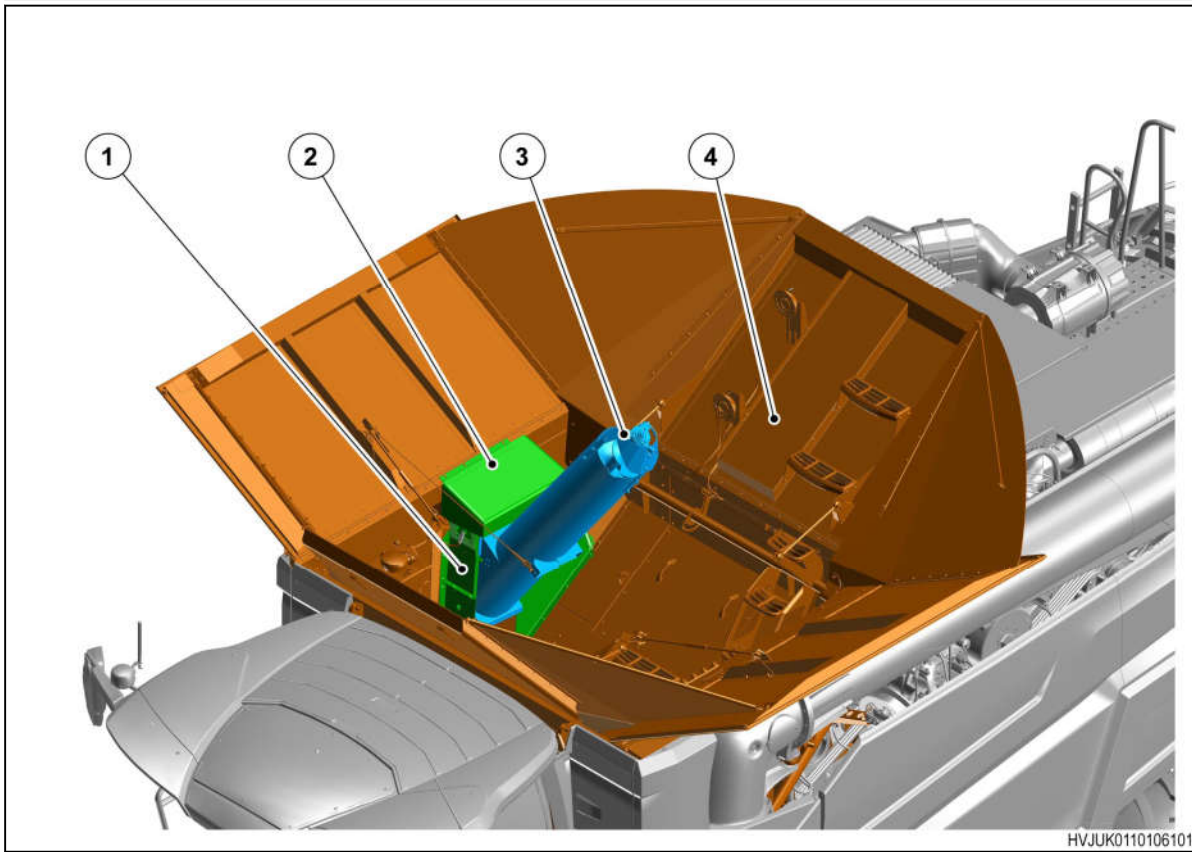





Fig. 48

- | | |
|----------------------------------------------------|-------------------------|
| (1) Tank filling elevator. | (3) Tank filling auger. |
| (2) Top access door for the tank filling elevator. | (4) Grain tank. |



The tank filling auger (3) is in the grain tank (4) and attaches to the top of the tank filling elevator (1).

The tank filling elevator (1) moves the grain up for the tank filling auger (3) to move the grain into the grain tank (4).

ParaLevel - transverse level

Level status of the machine	Icon
Machine body is level A slope grade less than 14%	
ParaLevel is at the maximum correction A slope grade of 14% to 24% A short sound alarm operates	
Dangerous level reached A slope grade of 24% to 30% A continuous sound alarm operates	

Standard axle - transverse level

Level status of the machine	Icon
A slope grade less than 10%	No icon
A slope grade of 10% to 16% A short sound alarm operates	
A slope grade of 16% to 20% Dangerous level reached A continuous sound alarm operates	

2. Introduction

- | | |
|--------------------------------------------------------|----------------------------------------------------------------|
| (6) Save/enable a configuration of the lamps | (12) Stow the cab ladder |
| (7) Rear work lamps (ON/OFF) | (13) Deploy the cab ladder |
| (8) Warning lamps (ON/OFF) | (14) Automatic operation of the beacon lamps (ON/OFF) |
| (9) Windshield wipers (ON/OFF) | (15) Lamps for the grain tank and the unloading auger (ON/OFF) |
| (10) Windshield wipers and windshield washers (ON/OFF) | (16) All maintenance lamps (ON/OFF) |
| (11) Mirror heaters (ON/OFF) | |

The button (6) is to save or enable a configuration of lamps:

- Set the necessary lamps to ON and press the button (6) to save this configuration.
- When the lamps are OFF, press the button (6) to set the same configuration of lamps to ON.

2.20.3.2 Switch panel module

Open the left rear shield of the machine to get access to the rear control panel.

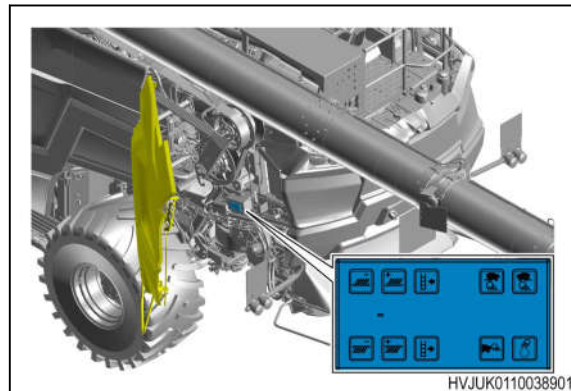

Fig. 77

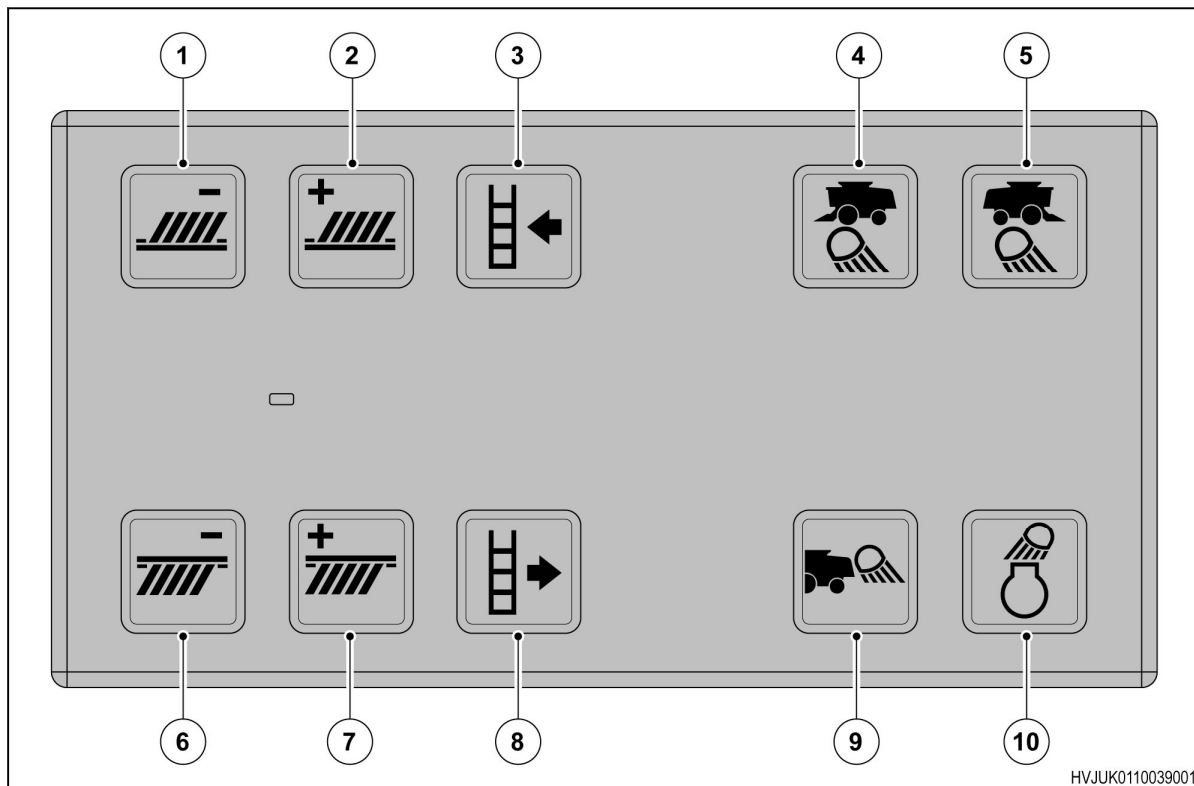



Fig. 78

(1) Top sieve close

(2) Top sieve open

5. Dry the touchscreen with an applicable soft, dry cloth.
6. Press  on the external control panel to go to the last screen.

2.21.2.7 Set the screen to day or night mode





To change the terminal touchscreen between day and night mode you can use:

- The touchscreen
- The external control panel and the touchscreen.

2.21.2.8 Use the touchscreen to set the day and night mode

To use the touch screen to swap between day mode and night mode on the terminal:



Procedure

1. Press the  button on the external control panel of the terminal to show the **Home Menu**.
2. Touch  to show the **Date and Time** display.
3. Touch  again to show the **Terminal Settings** menu.
4. Touch  to swap between day and night mode on the terminal.















2.21.2.9 Use the external control panel to set the day and night mode

To use the external control panel to swap between day mode and night mode on the terminal:

Procedure

1. Push the home menu layout button  on the external control panel to show layout menu.
2. Use the external control panel to navigate to and select  on the terminal to swap between day and night mode.

2.21.2.10 Terminal icon descriptions

Icon	Description	Icon	Description
	Machine diagnostic menu		Save
	Machine diagnostic menu selected		Share waylines
	ISOBUS information		Delete
	Start ISOBUS		Show the camera menu
	View ISOBUS information		Change the camera menu
	Terminal settings		Rear camera full view
	Screen calibration procedure		Map view (full to small)

2.21.4.2 Change the header settings

Before starting the procedure



WARNING: Moving components.

Risk of death or injury. The parts that move can hit persons.

Do not go in the dangerous areas of the machine during operation.

The operator of the machine must make sure that no person goes in the dangerous areas during operation.

To configure the header for operation, set the terminal to show the **Header Settings Basic** menu.

Procedure

1. Press the button on the external control panel of the terminal to show the **Home Menu**.
2. Touch to show the machine **Main Menu**.
3. Touch to show the **Header Settings Basic** menu.
4. Touch the text box (1) adjacent to Configuration.
5. Select the correct header from the configuration list or make a new configuration.
6. Touch to accept the configuration.
7. Touch for the set point 1 settings.
8. **NOTE:** When you change , increases or decreases by the same increment. is always a larger value than .
Use the header height control on the external control panel to change the height.
9. Touch for the set point 2 settings.
10. Use the header height control on the external control panel to change the height.
11. Touch the text box adjacent to .
12. Use the scroll wheel on the external control panel to change the cutting height control.
13. Touch the field pressure box (2).
14. Use the scroll wheel on the external control panel to change the field pressure.

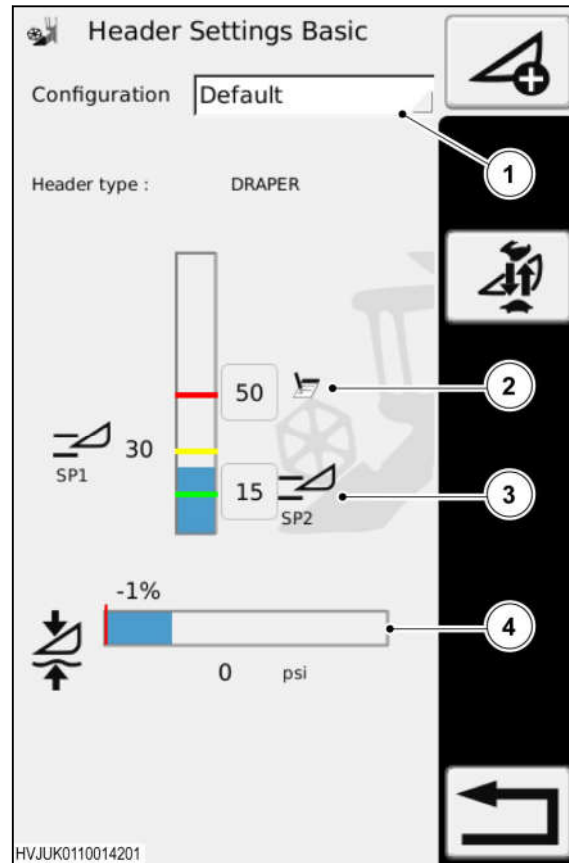









Fig. 98

3. Touch  to show the **Grain Discharge** menu.
 4. Touch  (1) to close the grain tank cover.
The icon  (1) changes color to blue  on the terminal to show the operation is in progress.
- NOTE:**
- In an emergency touch  to immediately stop the movement of the grain tank cover.*
- Touch  (1) again to continue to close the grain tank cover.*
5. Touch  (2) to close this menu and show the last menu. If it is necessary, press the  button on the external control panel to show the **Home Menu**.

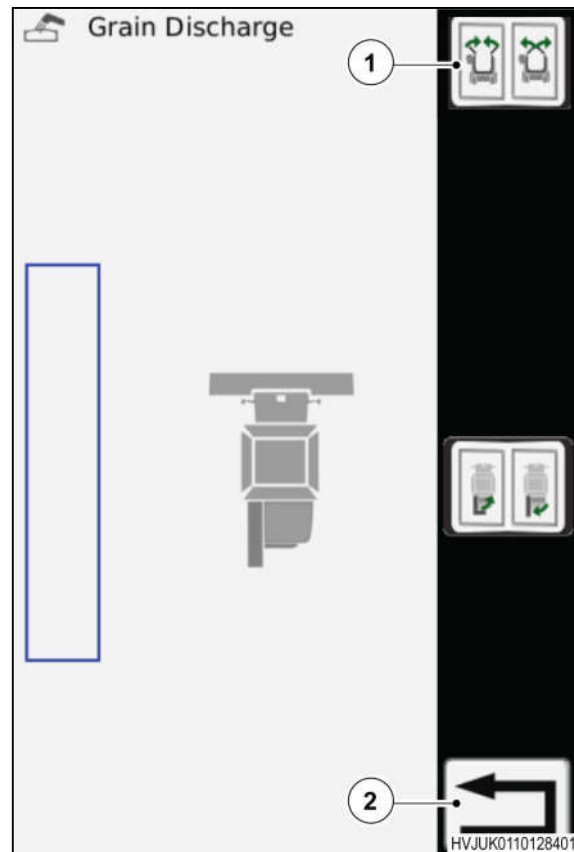

Fig. 109

Related Links

[Close the grain tank extensions](#) page 379

2.21.4.10 Fold the unloading auger

Before starting the procedure



WARNING: Moving components.

Risk of death or injury. The parts that move can hit persons.

Do not go in the dangerous areas of the machine during operation.



The operator of the machine must make sure that no person goes in the dangerous areas during operation.

The unloading auger is controlled from the terminal, set the terminal to show the **Grain Discharge** menu.

NOTE:

The unloading auger cannot move while the machine is in road mode.

Procedure

1. Press the  button on the external control panel of the terminal. The **Home Menu** shows.
2. Touch  to show the machine **Main Menu**.

Procedure

1. Press the button on the external control panel of the terminal to show the **Home Menu**.
2. Touch to show the machine **Main Menu**.
3. Touch to show the **Machine settings** menu.
4. To change a setting, touch a text box adjacent to the applicable setting (1-5).
5. Use the keyboard to enter a value into the text box.
6. Touch to save the changes.
7. Touch to close this menu and show the last menu. If it is necessary, press the button on the external control panel to show the **Home Menu**.

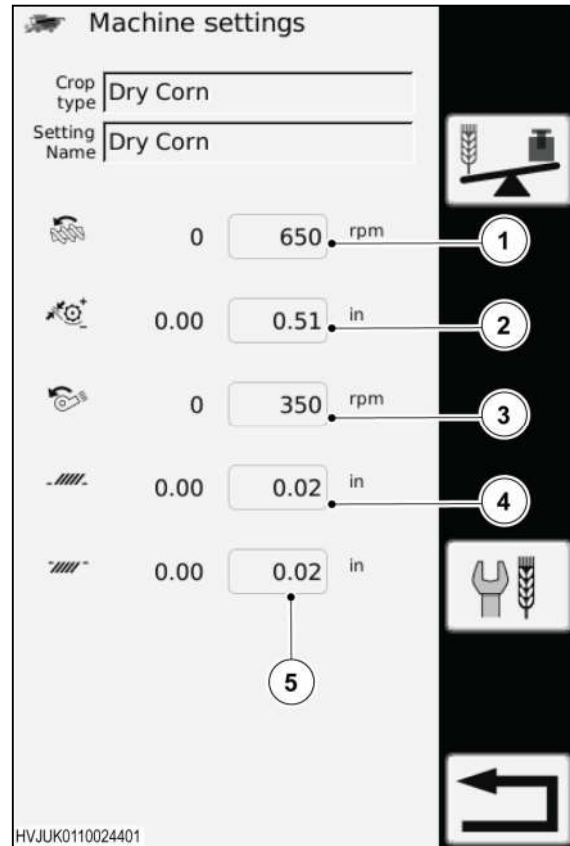

Fig. 125

- (1) The speed of the single/dual helix rotor.
- (2) The concave clearance dimension.
- (3) The speed of the cleaning fan.
- (4) The dimension of the top sieve opening.
- (5) The dimension of the bottom sieve opening.

2.21.4.20 Change the system features

To configure the cleaning, engine and ground drive system features, set the terminal to show the **System Features** menu.



Procedure

1. Press the button on the external control panel of the terminal to show the **Home Menu**.
2. Touch to show the machine **Main Menu**.

Constant flow setting

The constant flow  setting operates to keep the load on the threshing/separation system near to the set load (3).

NOTE:

The constant speed  setting is not available when you select the constant flow  setting.

The screen has 4 display/adjustment boxes for the:

- (1) Set minimum for the ground speed.
- (2) Set maximum for the ground speed.
- (3) Set load for the threshing/separation system (0% to 100%).
- (4) Reaction time (in seconds) for how quickly the threshing/separation system changes to the new load setting.

You can make adjustments to the display/adjustment boxes. Read the IDEALharvest information in the operation section of this Operator's Manual.

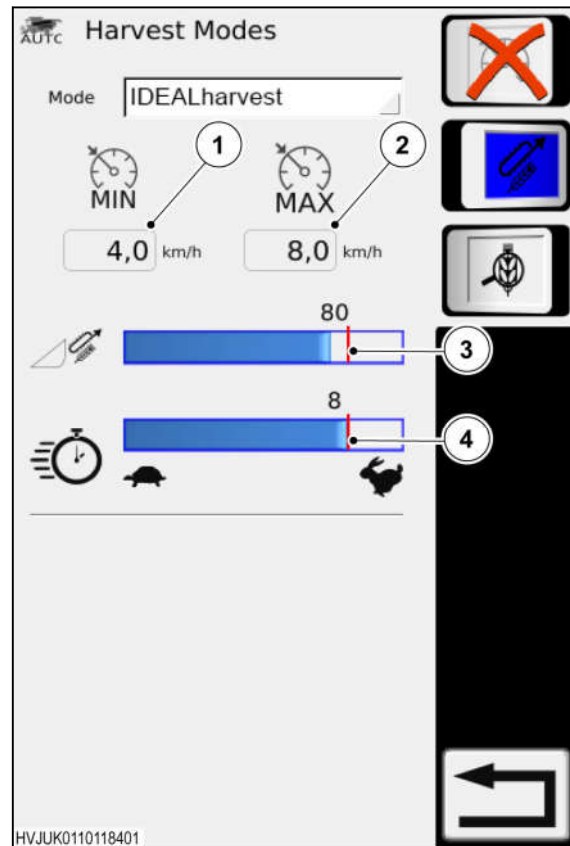

Fig. 137

2.21.6.12 Calibrate the guidance











WARNING: Moving components.

Risk of death or injury. The parts that move can hit persons.

Do not go in the dangerous areas of the machine during operation.

The operator of the machine must make sure that no person goes in the dangerous areas during operation.

Procedure

1. Press the  button on the external control panel of the terminal to show the **Home Menu**.
 2. Touch  to show the machine **Main Menu**.
 3. Touch  to show the **Calibrations** menu.
 4. Touch  to show the **Steering Sensor** menu.
 5. To calibrate the guidance systems that follow, touch  adjacent to the calibration and obey the instructions on the screen:
 - Steering valve
 - Wheel angle sensor
 - Row sensor
- NOTE:** If you do not obey all the instructions when you select , an audible alarm operates. If an audible alarm operates, stop the calibration procedure, correct the applicable fault and start the calibration procedure again. If the audible alarm continues to operate, speak to an approved dealer.
6. Touch  to close this menu and show the last menu. If it is necessary, press the  button on the external control panel to show the **Home Menu**.

2.21.6.13 Calibrate the level sensor







WARNING: Moving components.

Risk of death or injury. The parts that move can hit persons.

Do not go in the dangerous areas of the machine during operation.

The operator of the machine must make sure that no person goes in the dangerous areas during operation.

Procedure

1. Press the  button on the external control panel of the terminal to show the **Home Menu**.
2. Touch  to show the machine **Main Menu**.
3. Touch  to show the **Calibrations** menu.
4. Touch  to show the **Leveling sensors calibration** menu.

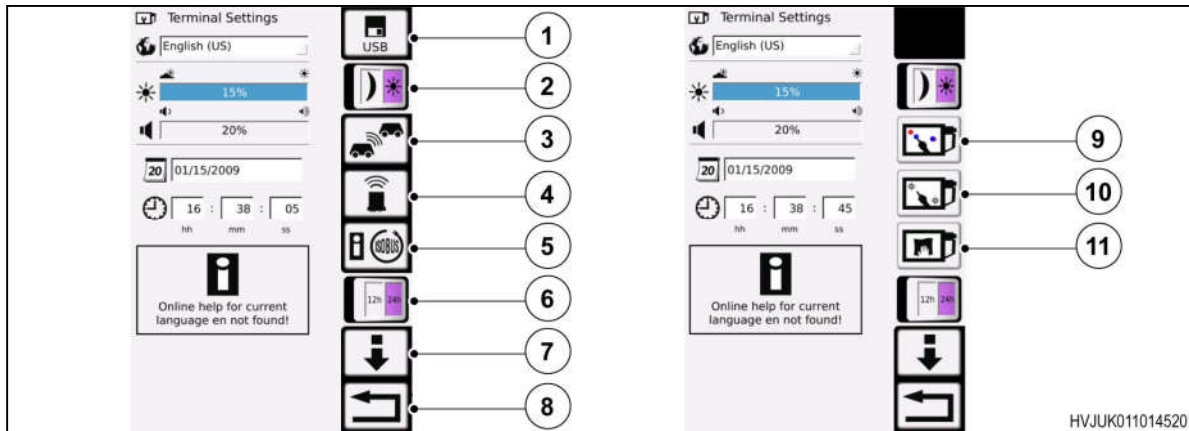

Fig. 158

- | | |
|----------------------------------------------------------------------------------------------------------------------------------------------------------------------------------------------------------------------------------------------------------------------------------------------------------------------------------------|----------------------------------------------------------------------------------------------------------------------------------------------------------------------------------------------------------------------------------------------------------------------------------|
| <ul style="list-style-type: none"> (1) Data exchange icon. (2) Toggle switch for day and night mode. (3) Machine to machine (M2M) communication icon. (4) AGCO connectivity module icon. (5) ISOBUS information icon. (6) Toggle switch for the 12 hour and 24 hour clock. | <ul style="list-style-type: none"> (7) Scroll icon. (8) Icon to go back to the Home Menu. (9) Touchscreen test icon. (10) Screen calibration icon. (11) Icon to disable the touchscreen function, to clean the screen. |
|----------------------------------------------------------------------------------------------------------------------------------------------------------------------------------------------------------------------------------------------------------------------------------------------------------------------------------------|----------------------------------------------------------------------------------------------------------------------------------------------------------------------------------------------------------------------------------------------------------------------------------|

2.21.10.3 Data exchange

To control the data stored on the terminal and USB storage devices, set the terminal to show the **Data exchange** menu.

1. Press the button on the external control panel of the terminal to show the **Home Menu**.
2. Touch to show the **Date and Time** display.
3. Touch again to show the **Terminal Settings** menu.
4. Touch to show the **Data exchange** menu.

- (1) Shows the data kept on the terminal.
- (2) Toggle switch to show the field data.
- (3) Toggle switch to show the machine settings data.
- (4) Toggle switch to show the task data.
- (5) Delete the data kept on the terminal.
- (6) Delete the data kept on the USB storage device.
- (7) Shows the data kept on the USB storage device.
- (8) Information icon.
- (9) Copy all the data kept on the USB storage device to the terminal.
- (10) Copy the selected data item to the terminal.
- (11) Copy the selected data item to the USB storage device.
- (12) Copy all the data kept on the terminal to the USB storage device.

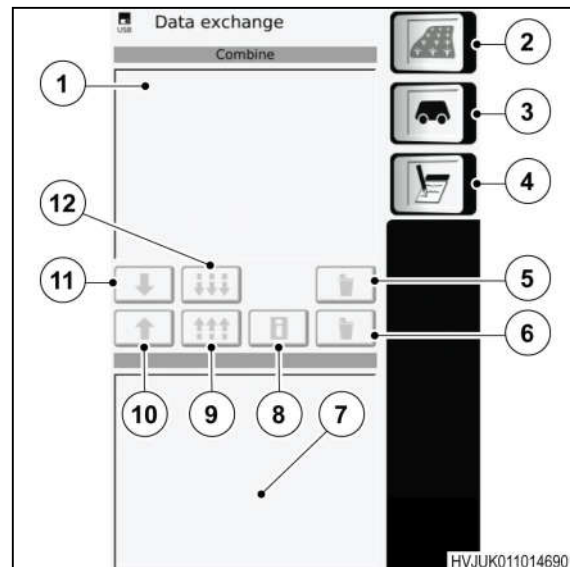





Fig. 159

2.21.11.8 Select a task**Procedure**

1. Press the  button on the external control panel of the terminal to show the **Home Menu**.
2. Touch  to show the **Documentation Pro** display.
3. Touch  again to show the **Documentation Main Menu**.
4. Touch the task text box (1).

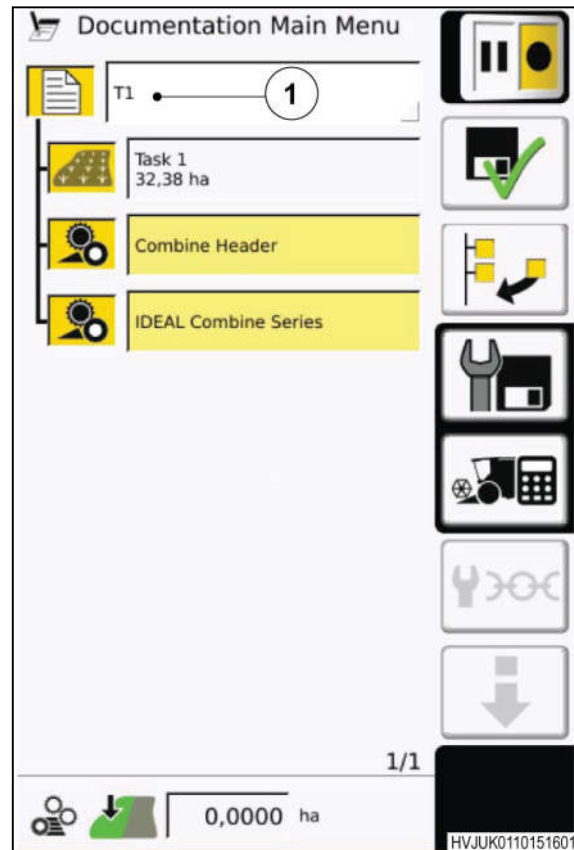

Fig. 176

Test number	Symbol	System test report
	✗	The PIN for the SIM is not correct. <ul style="list-style-type: none"> • Enter the correct PIN. • Wait for 15 minutes for the GPS to get a position. • Speak to an approved dealer.
10	✓	The TaskDoc server is connected with cellular data.
	✗	The TaskDoc server is not connected with cellular data. <ul style="list-style-type: none"> • No network is available. • The access data is not complete or is not correct. • Enable a data plan for the SIM.
11	✓	The TaskDoc server is found.
	✗	The TaskDoc server is not found. <ul style="list-style-type: none"> • Wait for the TaskDoc server to become available. • Speak to an approved dealer.
12	✓	The machine is found on the TaskDoc server.
	✗	The machine is not found on the TaskDoc server. <ul style="list-style-type: none"> • Speak to an approved dealer.
13	✓	The user license for the machine is valid.
	✗	The user license for the machine has expired. <ul style="list-style-type: none"> • To extend the license, speak to an approved dealer.
14	✓	The machine is registered to a customer in the TaskDoc server.
	✗	The machine is not registered to a customer in the TaskDoc server. <ul style="list-style-type: none"> • Speak to an approved dealer.
15	✓	The system test is complete with no faults.
	✗	The system test is complete with faults.

2.21.12 Machine to machine communication

Machine to machine (M2M) communication is only available if you subscribe to the advanced AgCommand app. Register each machine with the AgCommand app to setup a work group.

The M2M software enables communication (between the machines in a work group) to share data for the:

- Guidance system waylines.
- Machine settings (setpoints) for the operation of the threshing/separation system and the cleaning system.

Road mode display

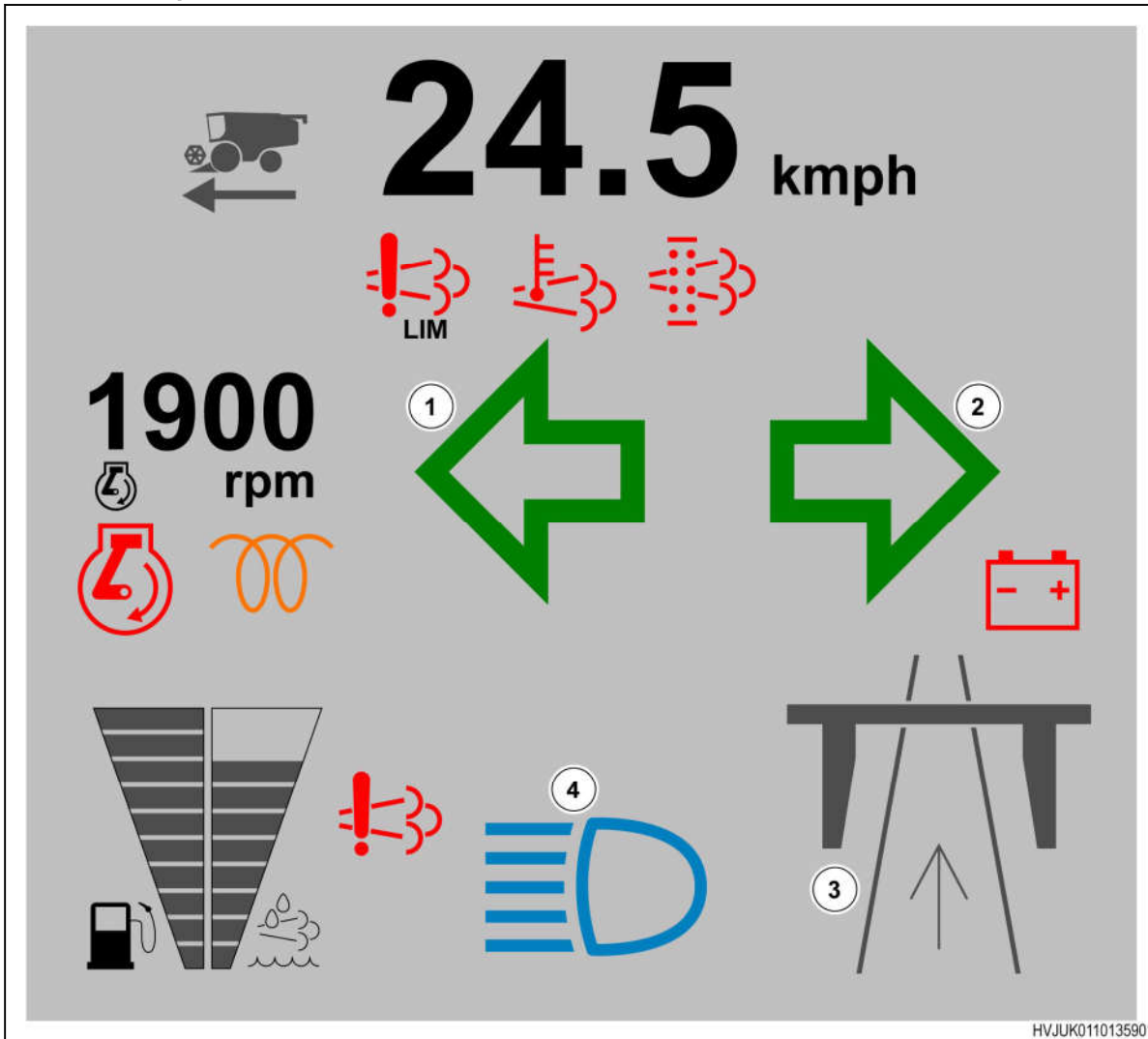

Fig. 193

- | | |
|---------------------|---------------|
| (1) Left indicator | (3) Road mode |
| (2) Right indicator | (4) Full beam |

2.22.4 Console controls

- (1) Hand throttle (engine rpm speed)
- (2) Header switch (engage/reverse)
- (3) Threshing and separation switch
- (4) Switch for rear wheel assist
- (5) Parking brake switch

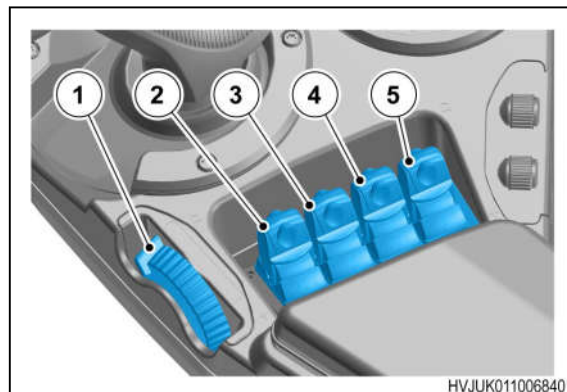

Fig. 194

2.22.6 Seat**2.22.6.1 Operator's seat**

Fig. 209

- (1) Seat belt latch plate
- (2) Switch for the seat climate control adjustment (optional equipment)
- (3) Lumbar support switch (optional equipment)
- (4) Backrest tilt adjustment lever
- (5) Seat belt buckle
- (6) Switch for weight and height adjustment
- (7) Control lever to adjust the vertical shock absorber
- (8) Forward and rearward adjustment control lever
- (9) Seat depth control lever
- (10) Seat tilt control lever

2. Introduction

The cab ladder (5) is attached to the left side of the cab. You can remove the engine platform ladder and then attach it to other areas of the machine.

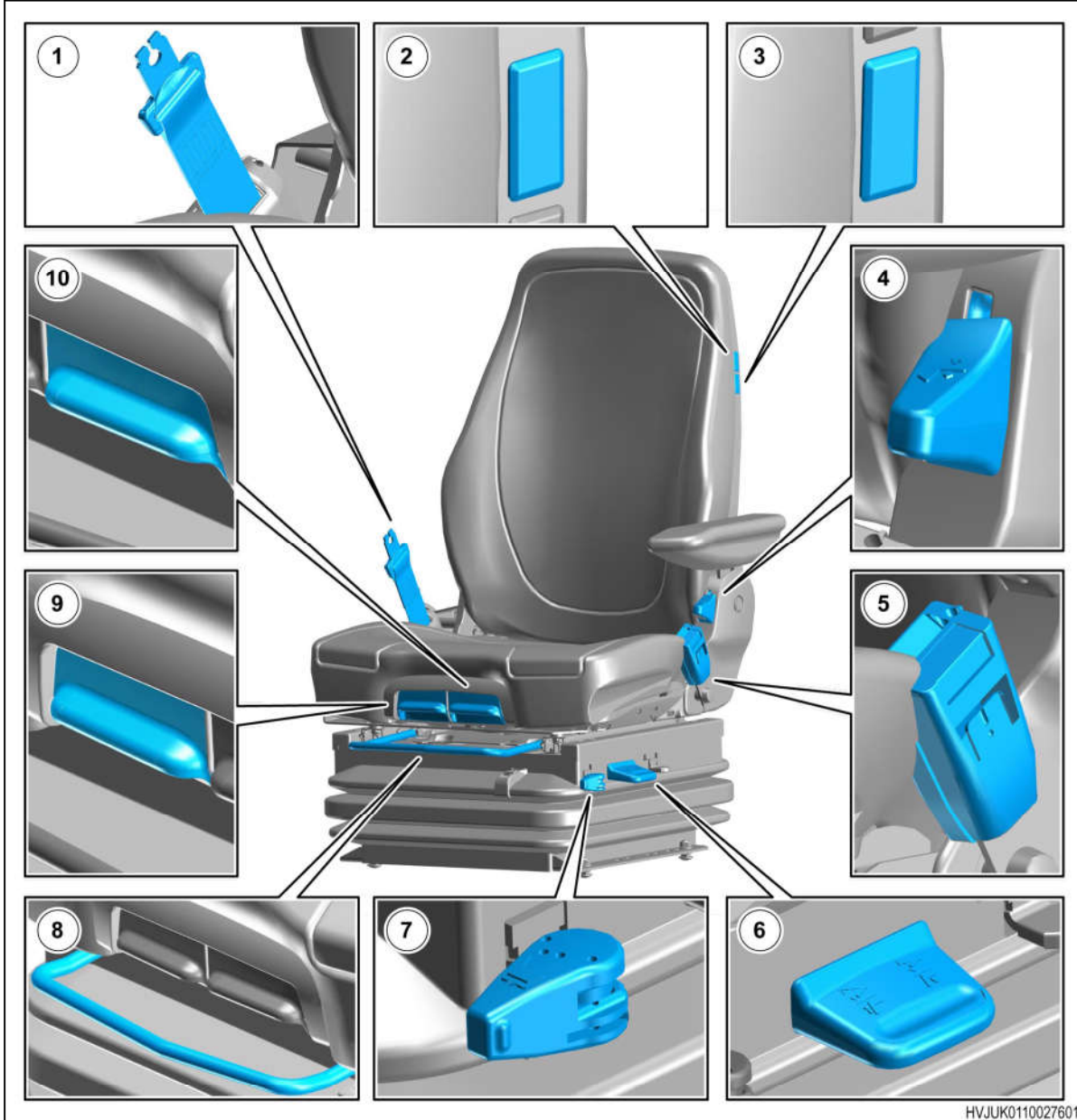
2.26.2 Quick start

2.26.2.1 Guidance menu tree

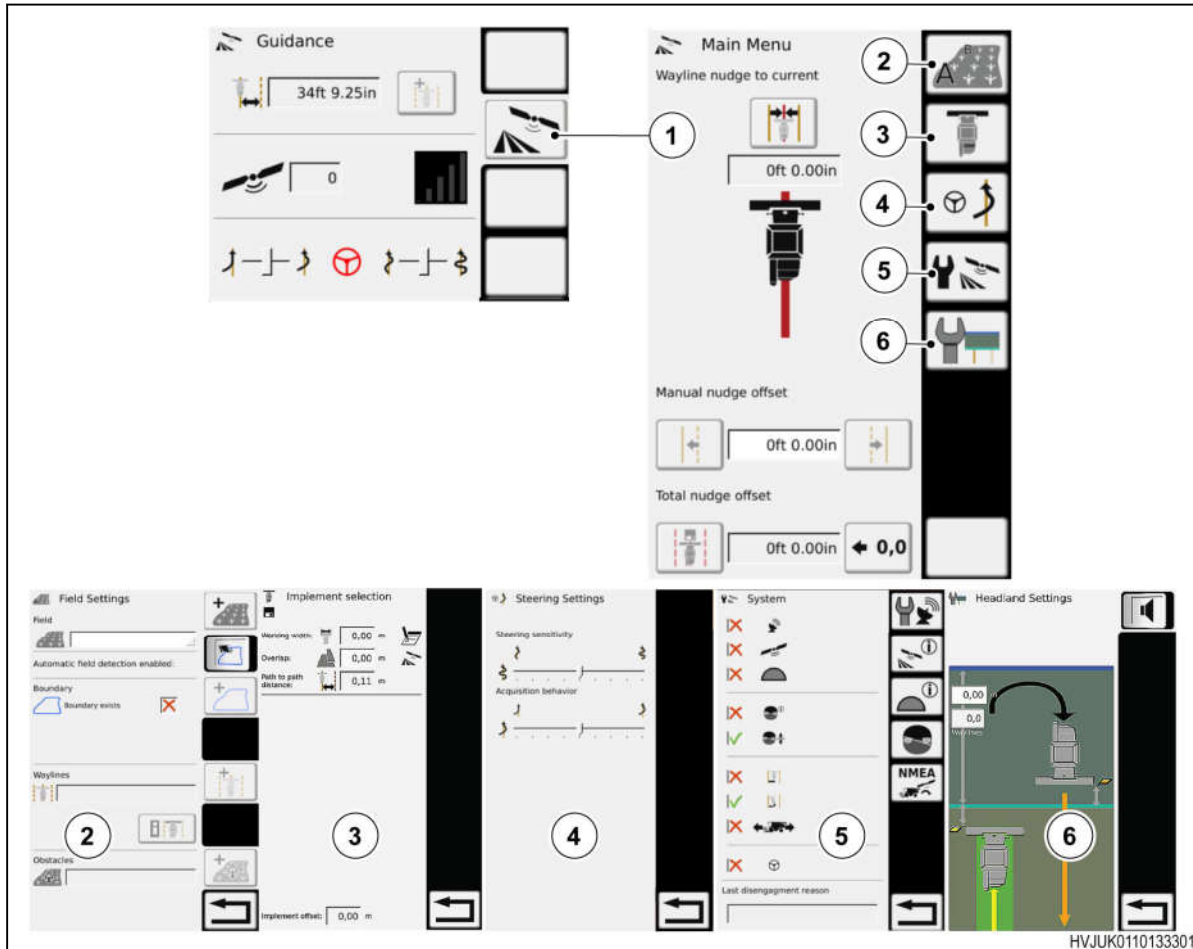







Fig. 224

You can set the terminal to show the guidance **Main Menu**. This shows the menu keys to let you see the different guidance menus for the automatic guidance system:

- Touch  (1) to show the guidance **Main Menu** (1).
- Touch  (2) to show the **Field Settings** menu (2).
- Touch  (3) to show the **Implement selection** menu (3).
- Touch  (4) to show the **Steering Settings** menu (4).
- Touch  (5) to show the **System** menu (5).
- Touch  (6) to show the **Headland Settings** menu (6).

2.26.3.2 Guidance map view

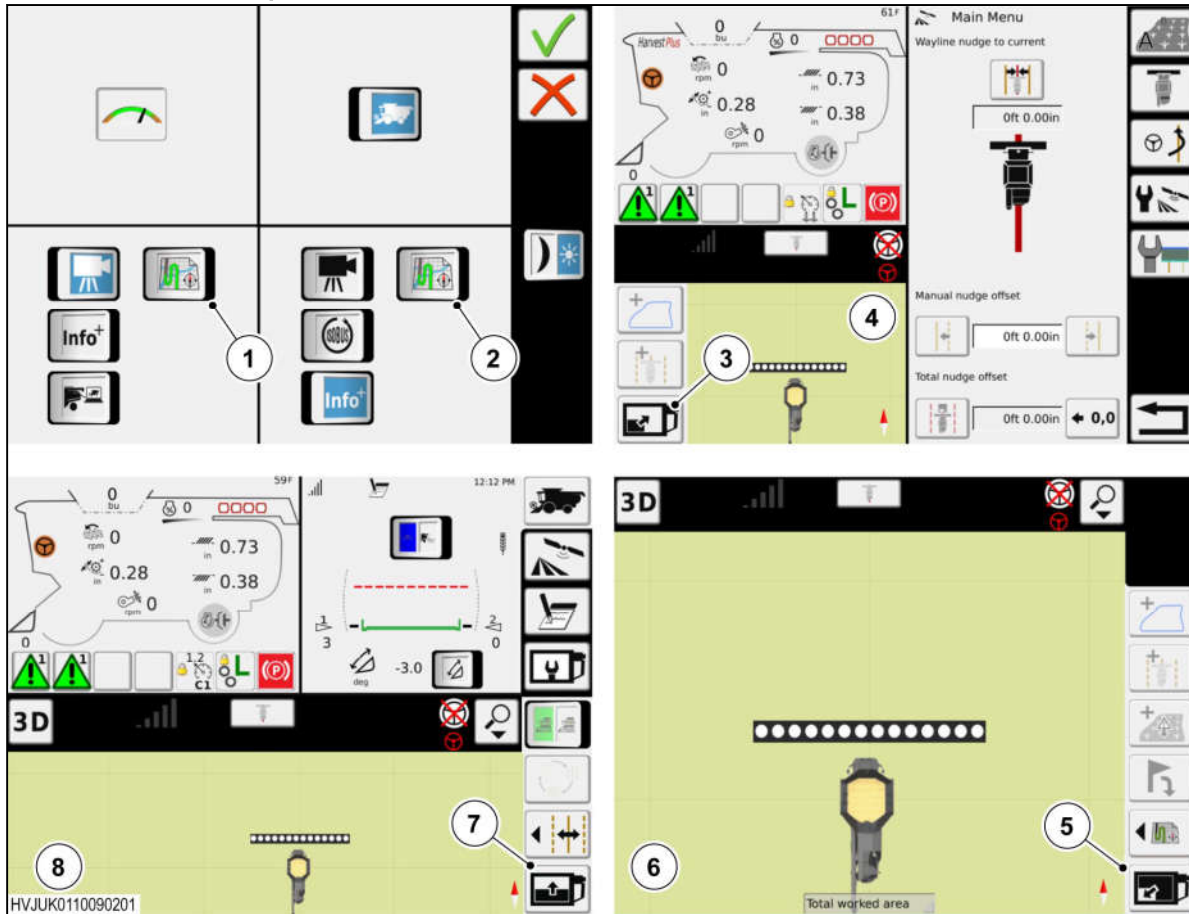

Fig. 232

You can set the terminal to show the map view in different dimensions:

- Small (quarter) view (4)
- Half view (8)
- Full view (6).

The terminal has an external control panel with buttons. Operate the buttons to show and select the different map view layouts for the **Home Menu**.

Press the button on the external control panel, to set the terminal to show the layout selections.

- To set the **Home Menu** to show the map view in a small (quarter) view (4):
 - Touch (1) to show the map view on the bottom left side.
 - Touch (2) to show the map view on the bottom right side.
- To set the **Home Menu** to show the map view in a half view (8):
 - Touch (1) and then touch (2).

Press the button on the external control panel, to set the terminal to show the **Home Menu**.

Touch the related menu key to change the position or the dimensions of the map view:

2.26.4.2 Correction signals

Receiver type	Precision	Correction signal
NovAtel SMART6-L	Submetre	Autonomous
		EGNOS/WAAS
		Terrastar-L
	Decimetre	Terrastar-C
Centimetre	Real-Time Kinematics (RTK) unit	<ul style="list-style-type: none"> • Sate EASY-Proof radio modem • External Radio modem
		RTK network

Receiver type	Precision	Correction signal	
Trimble 382	Submetre	Autonomous	
		EGNOS/WAAS	
		RangePoint RTX	
	Decimetre	CenterPoint RTX	
	Centimetre	RTK unit	<ul style="list-style-type: none"> • AG-715 Radio • External Radio modem
			RTK network
		CenterPoint VRS	

2.26.4.3 Correction signal type

The automatic guidance system uses correction signals to get the best precision to automatically steer the machine along specified waylines.

You can set the terminal to show the **Correction Signal** menu. This lets you see and make a selection from the types of correction signals that are available.

Before starting the procedure

Press the  button on the external control panel of the terminal to show the **Home Menu**.

You can set the terminal to show the **Field Settings** menu. This lets you see the list of specified field obstacles for the operation of the automatic guidance system.

1. Press the button on the external control panel of the terminal to show the **Home Menu**.
2. Touch to show the **Guidance** menu.
3. Touch to show the guidance **Main Menu**.
4. Touch to show the **Field Settings** menu.
5. Touch the Obstacles text box to see the list of saved obstacles.

You can select an obstacle from the list to change or delete it.

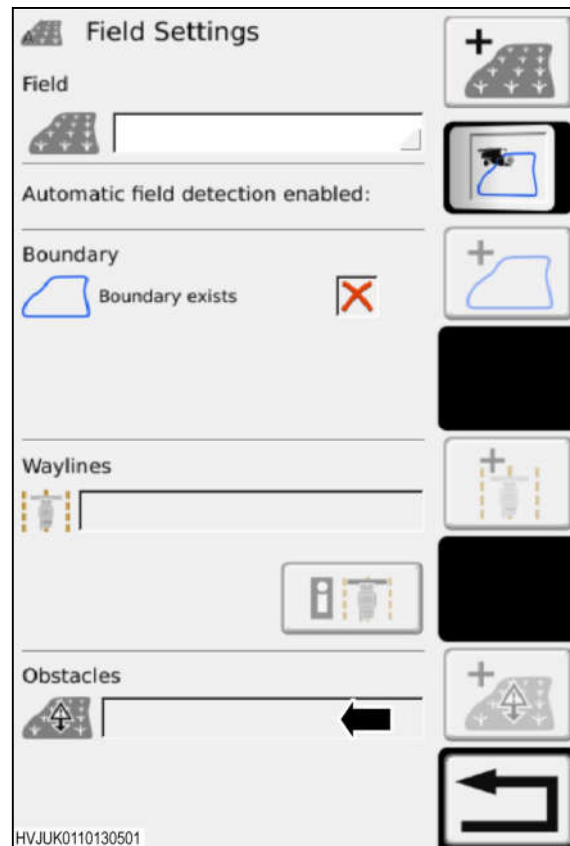

Fig. 253

2.26.5.4 Set a point obstacle

You can set the terminal to show the **Type of obstacle** menu. This lets you select and set an obstacle point for the operation of the automatic guidance system.

Before starting the procedure

Move the machine to the necessary area and safely park it at the obstacle point.

Press the button on the external control panel of the terminal to show the **Home Menu**.

Procedure

1. Touch to show the **Guidance** menu.
2. Touch to show the guidance **Main Menu**.
3. Touch to show the guidance **Field Settings** menu.

3. Touch to show the **Field Settings** menu.

4. Touch the Field text box (1).

Result

A list shows for all the known fields.

5. Touch the applicable field that the wayline is to be in.

Result

The list of known fields closes.

6. Do a visual check for the condition of the Boundary exists checkbox (2).

a) The shows a known field boundary. You can add a wayline to the field.

b) The shows an unknown field boundary. If this shows, then it is necessary for you to do the procedure to record a boundary for the field.

7. Touch (3) to show the **Type of Wayline** menu.

8. Touch Contour to make the wayline selection.

9. Touch to save the selection.

Result

The **Type of Wayline** menu closes to show a map view with the applicable record menu keys.

10. Touch to start the record procedure for the contour wayline.

- You can stop and start the record procedure.

- Touch to temporarily stop the record procedure.

- Touch to start the record procedure again.

11. Move the machine along the necessary contour to the end point of the new wayline.

NOTE:

shows for selection after you move the machine for the minimum distance that is necessary to make a contour wayline.

12. Touch to complete the record procedure.

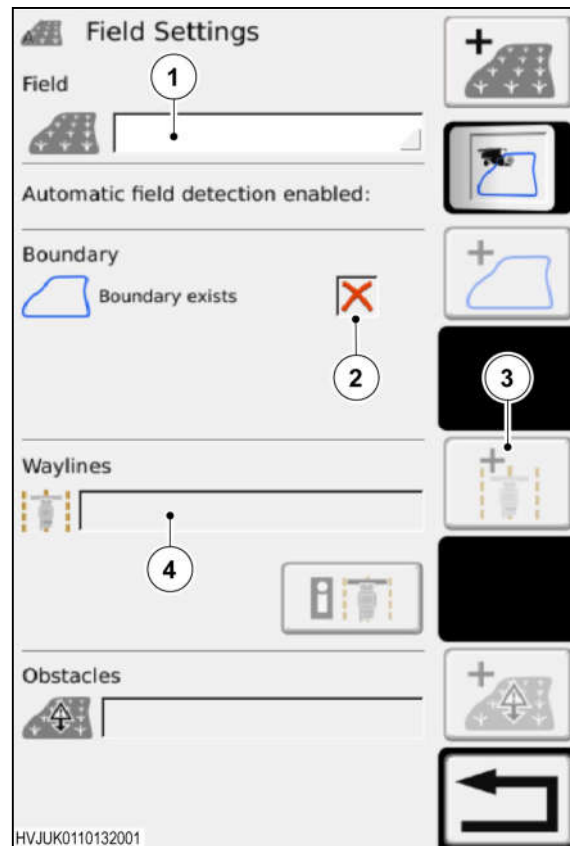

Fig. 266

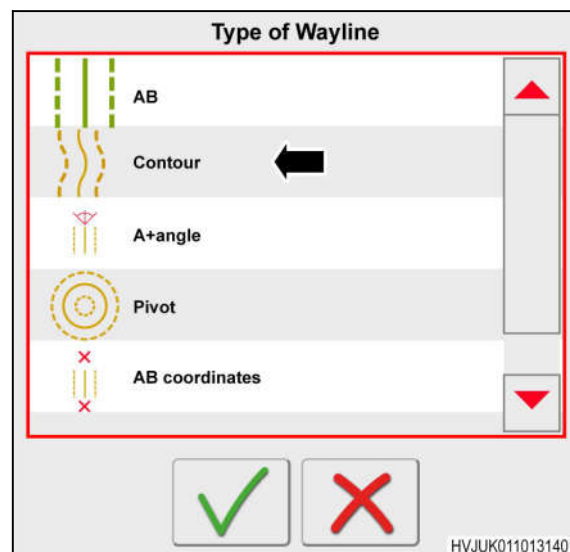

Fig. 267

3.2.2.3 Examine the elevator speed sensor



DANGER: The machine has many mechanical parts that move.

The parts that move can hit persons.

Do not go in the dangerous areas of the machine during operation. The operator of the machine must make sure that no person goes in the dangerous areas during operation.

You can set the terminal to show the **Shaft speeds** menu. The output of the elevator speed sensor shows here.

Procedure

1. Start the engine.
2. Press the button on the external control panel, to set the terminal to show the layout selections.
3. Touch on 1 of the 2 bottom menus to show the **Info+** menu.
4. Touch to show the **Shaft speeds** menu.
5. Operate the threshing/separation system.
6. Set the engine to a high idle speed.
7. Make sure that the elevator speed shows a minimum of:
 - 430 RPM for the high speed.
 - 250 RPM for the low speed.
8. Touch to go back to the **Home Menu**.

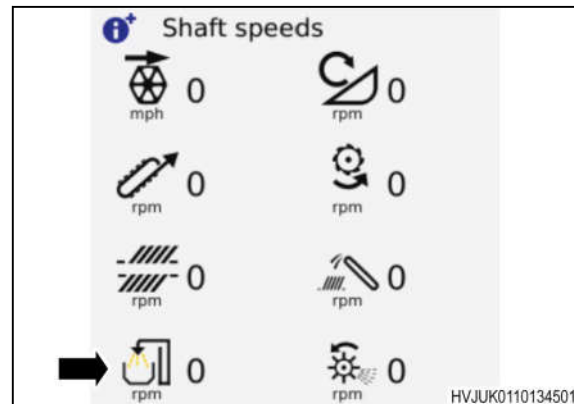

Fig. 4

3.2.2.4 Examine the ground speed sensor



DANGER: The machine has many mechanical parts that move.

The parts that move can hit persons.

Do not go in the dangerous areas of the machine during operation. The operator of the machine must make sure that no person goes in the dangerous areas during operation.

Procedure

1. Set the engine to ON.
2. Move the machine forward.
3. Look at the ground speed value shown on the terminal.
 - If the ground speed value shown on the terminal is correct, it is not necessary to calibrate the ground speed sensor.
 - If the ground speed value shown on the terminal is not correct, it is necessary to calibrate the ground speed sensor.
4. Speak to your AGCO dealer to set the tire size.

3.5 Locations to attach transport safety chains



WARNING: The machine can move without warning.

The machine is heavy and can cause death or injury.

Park the machine on a clean, hard and level area. Set the parking brake to ON and install the wheel chocks.



WARNING: The machine has parts that move without operator input.

The parts that move can hit persons.

Stop the engine on the machine and remove the ignition key.



DANGER: Falling components.

The machine can fall and cause death or injury if you do not use the supports.

Make sure that you use lift equipment specified for the weight of the machine.

When you lift the machine, put the supports in the correct positions.

Refer to the instructions prepare to transport the machine on a trailer.

Front axle

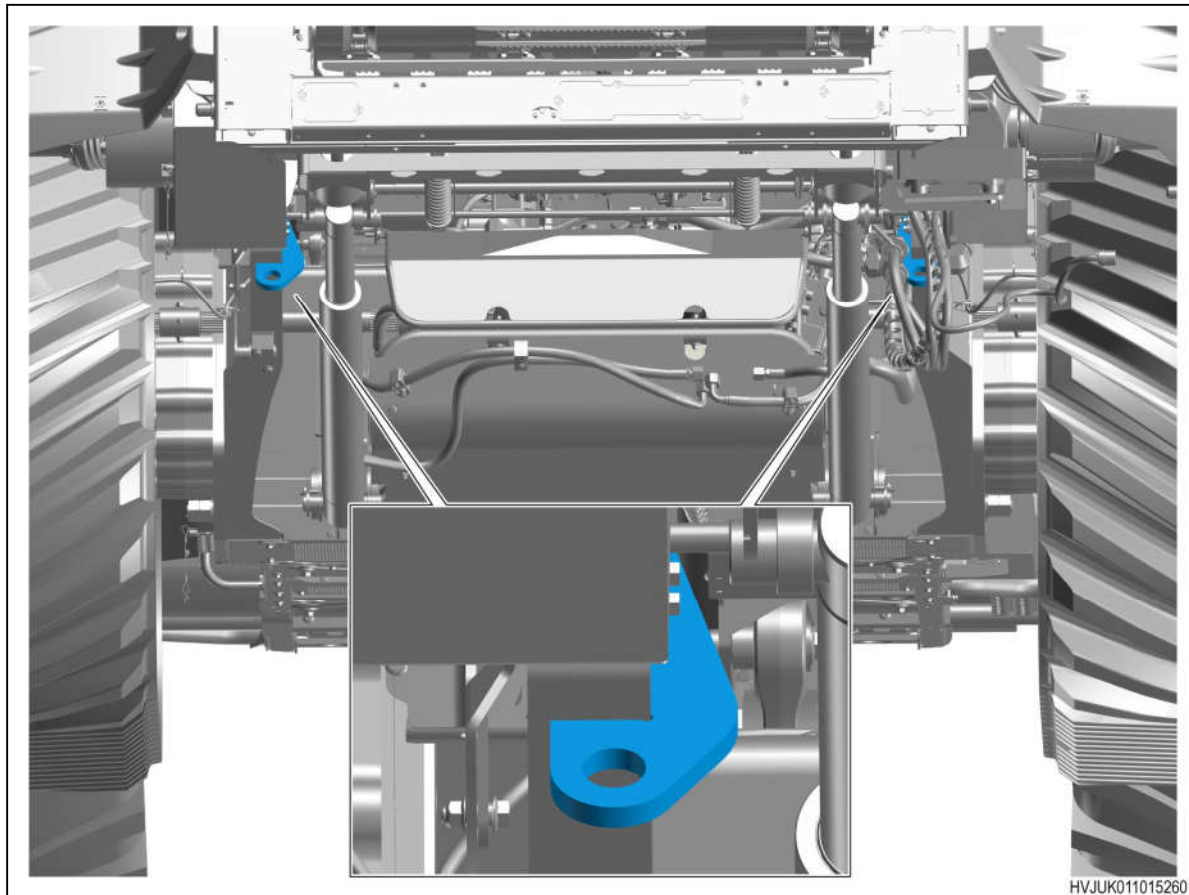

Fig. 13

NOTE: Make sure that you install the safety device for the header cylinder after you lift the feeder housing.

There is a chassis bracket on each side of the front axle.

- The maximum approved time for continuous operation at a low idle speed is 30 minutes.
- The maximum approved time for continuous operation at a high idle speed is 15 minutes.

After each idle speed cycle, operate the engine with a minimum of 40% of the maximum rated power for a minimum of 30 minutes. Do not use more than 15% from the total power of the engine when you operate at low load or at an idle speed.

If the engine operation is more or less than the tolerances shown, it can cause the results that follow:

1. Leakage of oil from the exhaust system.
 - Continuous operation at no load or low load causes a decreased combustion temperature. This puts soot into the exhaust system and can cause damage to the injectors, valves, and piston rings. This can cause leakage through the exhaust manifold, the turbocharger connections and other components.
2. Soot in the cylinder heads, the exhaust manifold and in the exhaust system.
 - Fuel that does not burn, oil fumes and soot can cause contamination to the exhaust ports, the cylinder heads and the exhaust manifold.
3. Engine oil contamination
 - Fuel that does not burn can cause contamination in the engine oil. This can decrease the quality of engine lubricant, which can cause engine components to wear at a faster rate.
4. Smoke
 - Soot in the engine and the engine exhaust can cause the engine to make too much smoke.

IMPORTANT:

A large quantity of soot in the exhaust system can cause the catalyst to malfunction.

3.8.2 Move the machine forward or rearward

3.8.2.1 Transmission gear selection

You must operate the machine in a low speed range setting when you harvest.

Put the machine in a low speed range setting to make sure that the hydrostatic drive does not stop the machine. Do this in conditions where:

- Increased power is necessary.
- You do work on a slope with a full load.

3.8.2.2 Multifunction lever



DANGER: The machine has many mechanical parts that move.

The parts that move can hit persons.

Do not go in the dangerous areas of the machine during operation. The operator of the machine must make sure that no person goes in the dangerous areas during operation.

Put the multifunction lever into the neutral position before you start the engine.

The transmission does not have a reverse gear. You can use the multifunction lever to move the hydrostatic motor outputs in the reverse direction in all transmission ranges.

Move the multifunction lever slowly when you:



- Increase or decrease the speed.
- When you go into or go out of a reverse direction.

When you move the multifunction lever to the neutral position, the hydrostatic motor decreases the speed and stops the machine.

Do not operate the machine with the multifunction lever near to the neutral position. Put the speed range into the lower setting and move the multifunction lever away from the neutral position.







Constant flow and performance

Procedure

1. Touch  (4) and then  (5) to set the machine to do the harvest procedure with a constant flow of the crop (and the best possible quality of grain).

Result

The terminal screen shows this menu when:

- The disengaged condition  changes to the engaged condition  (4).
 - The disengaged condition  changes to the engaged condition  (5).
 - The available condition  changes to the not available condition  (3).
2. To make the adjustments to the display or adjustment boxes (1), (2), (6), (7), (9) and (10):
 - a) Touch a display/adjustment box.
 - b) Turn the scroll wheel on the external control panel of the terminal.
 - c) Press the scroll wheel to save the adjustment.

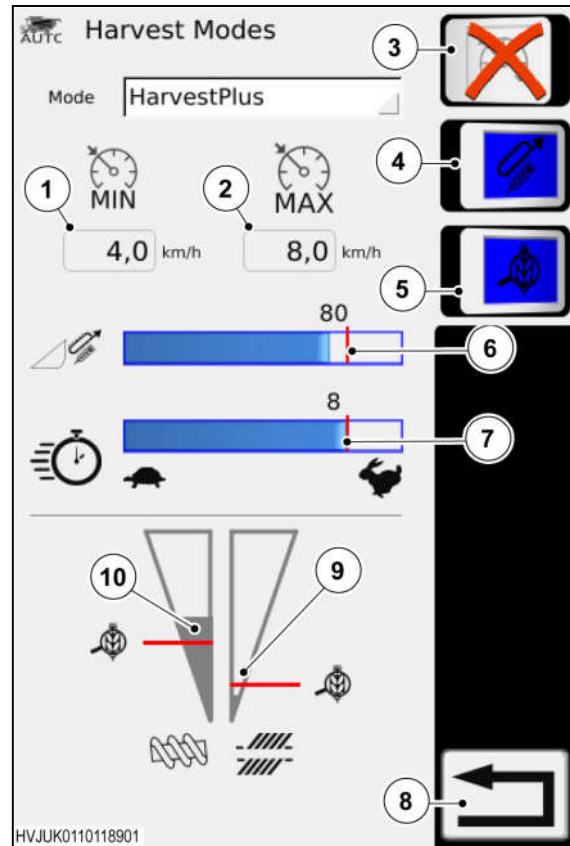



Fig. 39



3. Touch  to close this menu and show the last menu. If it is necessary, press the  button on the external control panel to show the **Home Menu**.

3.8.4.2 IDEALharvest operation

Before starting the procedure

IMPORTANT: The IDEALharvest mode can only harvest a crop correctly in dry conditions. The crop must also be in a constant vertical position (not bent or on the ground). The IDEALharvest mode can also do all the HarvestPLUS functions.

Procedure

1. Press the  button on the external control panel of the terminal to show the **Home Menu**.
2. Touch  to show the machine **Main Menu**.

3.9.1.21 Rye

It is recommended that you use these settings, but adjust the settings if it is necessary.

Rye	
Rotor speed	920 rpm to 950 rpm
Cleaning fan speed	950 rpm
Concave clearance	10 mm
Concave configuration	Small grain
Separator configuration	Finger
Top sieve position	16 mm
Bottom sieve position	8 mm

3.9.1.22 Safflower

It is recommended that you use these settings, but adjust the settings if it is necessary.

Safflower	
Rotor speed	700 rpm
Cleaning fan speed	1000 rpm
Concave clearance	7 mm
Concave configuration	Small grain
Separator configuration	Not required
Top sieve position	22 mm
Bottom sieve position	17 mm

3.9.1.23 Sorghum

It is recommended that you use these settings, but adjust the settings if it is necessary.

Sorghum	
Rotor speed	600 rpm
Cleaning fan speed	650 rpm
Concave clearance	25 mm
Concave configuration	Small grain
Separator configuration	Finger
Top sieve position	13 mm
Bottom sieve position	8 mm

3.9.1.24 Soybean

It is recommended that you use these settings, but adjust the settings if it is necessary.



WARNING: The machine has parts that move without operator input.

The parts that move can hit persons.

Stop the engine on the machine and remove the ignition key.

The procedure shows the movement of the belts and pulleys from the fast setting to the slow setting. Use the slow setting for corn headers.

Procedure

1. Lift the feeder housing and install the cylinder stop.
2. Remove the right feeder housing shield.
3. Remove the fastener and remove the tool.
4. Put the tool (1) in the square hole (2) in the tensioner assembly.

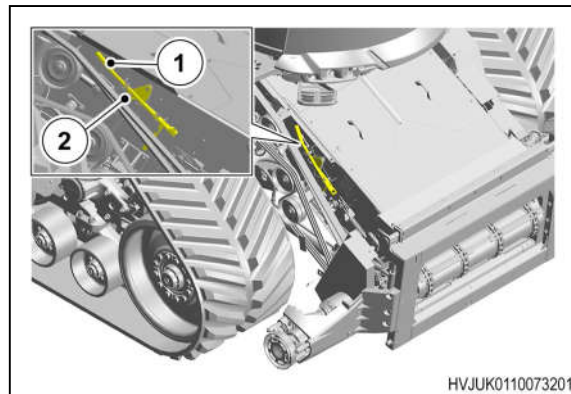

Fig. 55

5. Use the tool to push the tensioner down. Move the belt off of the tensioner pulley.
6. Remove the tool from the tensioner.

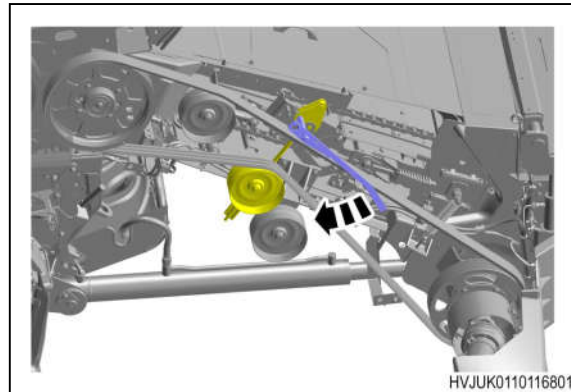

Fig. 56

7. Use the hexagon drive on the tool to loosen the 3 fasteners on the pulley.
8. Turn the large pulley clockwise, then pull the large pulley away from the small pulley.
9. Hold the large pulley on the 3 outer fasteners and turn the large pulley counterclockwise.

3.9.7 Cleaning system

3.9.7.1 Adjust the sieves

Before starting the procedure



WARNING: The machine can move without warning.

The machine is heavy and can cause death or injury.

Park the machine on a clean, hard and level area. Set the parking brake to ON and install the wheel chocks.

You can adjust the sieves from the console in the cab.

- (1) Close the top sieve
- (2) Open the top sieve
- (3) Open the bottom sieve
- (4) Close the bottom sieve

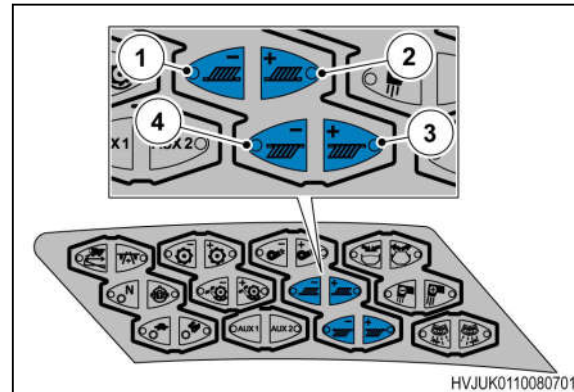

Fig. 77

You can adjust the sieves with the control panel on the rear left side of the machine.

- (1) Close the top sieve
- (2) Open the top sieve
- (3) Open the bottom sieve
- (4) Close the bottom sieve

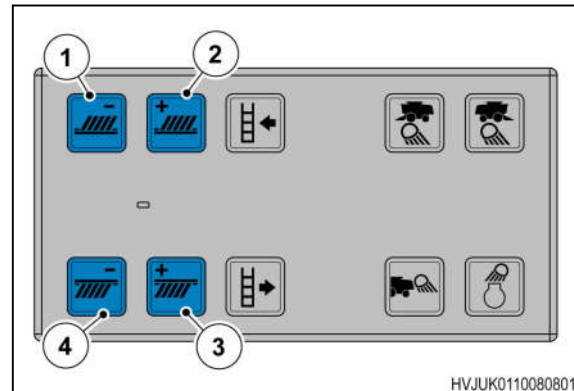

Fig. 78

- 4. Remove the 4 fasteners.
- 5. Remove the shield.

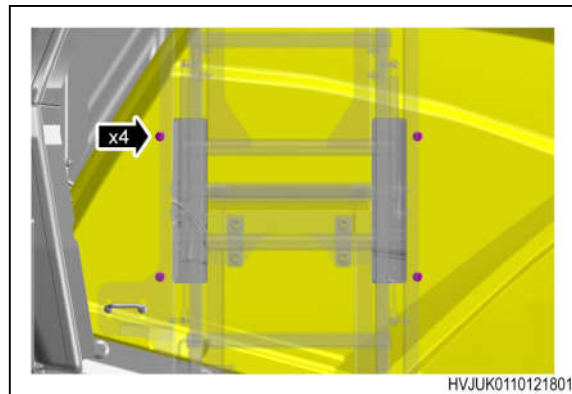

Fig. 102

- 6. Remove the fastener.
- 7. Install the fastener in the bottom hole.

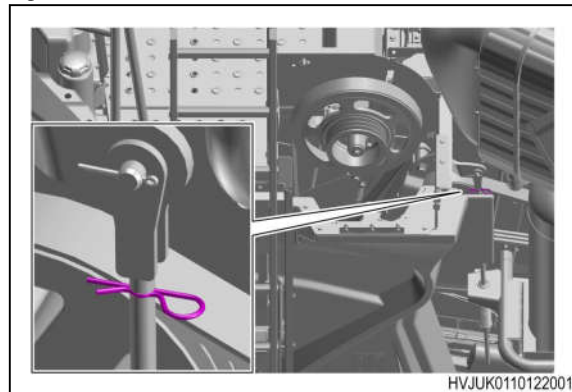

Fig. 103

- 8. Move the straw chopper to its center position.

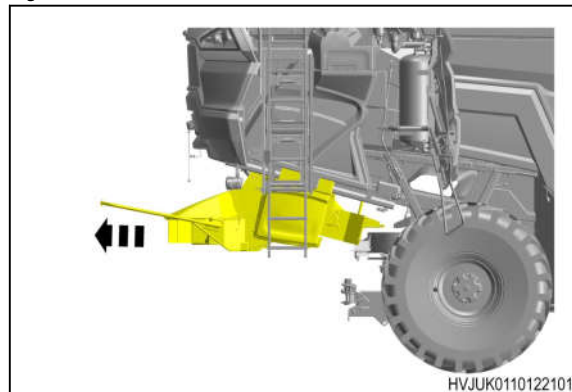

Fig. 104

- 9. This graphic shows the position for low speed.

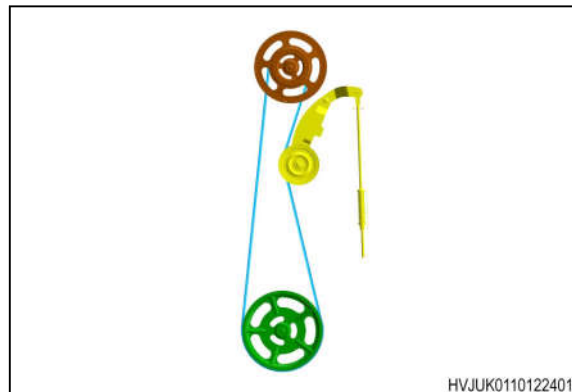

Fig. 105

CLICK HERE TO **DOWNLOAD** THE COMPLETE MANUAL

- Thank you very much for reading the preview of the manual.
- You can download the complete manual from: www.heydownloads.com by clicking the link below



- Please note: If there is no response to CLICKING the link, please download this PDF first and then click on it.

CLICK HERE TO **DOWNLOAD** THE COMPLETE MANUAL

2. Remove the fastener (1) from the pin (2).
3. Hold the chaff spreader and pull out the pin (2).
4. Lower the chaff spreader.
5. Push the pin (2) back.
6. Install the fastener (1).

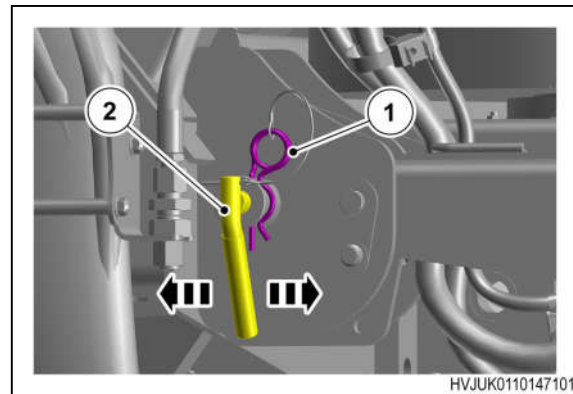

Fig. 128

3.9.10.5 Unfold the chaff spreader



WARNING: The machine can move without warning.

The machine is heavy and can cause death or injury.

Park the machine on a clean, hard and level area. Set the parking brake to ON and install the wheel chocks.



WARNING: The machine has parts that move without operator input.

The parts that move can hit persons.

Stop the engine on the machine and remove the ignition key.

Procedure

1. Make sure that the chaff spreader is in the closed position.
2. Remove the fastener (1) from the pin (2).
3. Hold the chaff spreader and pull out the pin (2).
4. Lift the chaff spreader to the correct position.
5. Push in the pin (2).
6. Install the fastener (1).

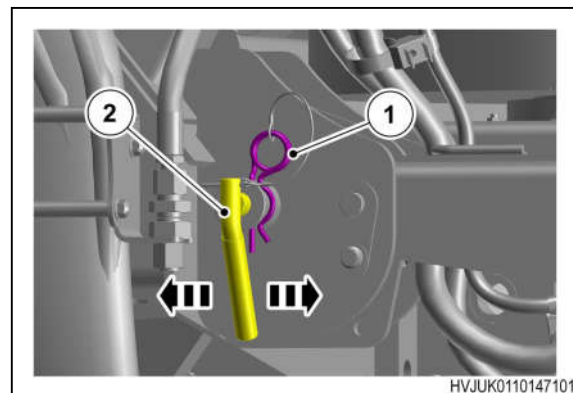

Fig. 129

5. Move the shield to the top position. Do a check that the gas strut holds the shield in position.

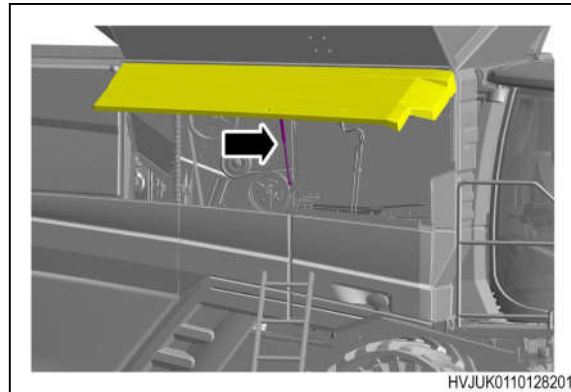

Fig. 149

Related Links

[Shield tool](#) page 51

3.10.12 Close the right front shield



WARNING: The machine can move without warning.

The machine is heavy and can cause death or injury.

Park the machine on a clean, hard and level area. Set the parking brake to ON and install the wheel chocks.



WARNING: The machine has parts that move without operator input.

The parts that move can hit persons.

Stop the engine on the machine and remove the ignition key.



WARNING: Falling off, or into the machine.

Falls from height cause death or injury.

Use the applicable access equipment when you do work at height.

Procedure

1. Use the ladder from the engine compartment to get access to the shield.



Fig. 150

2. Open the cover.

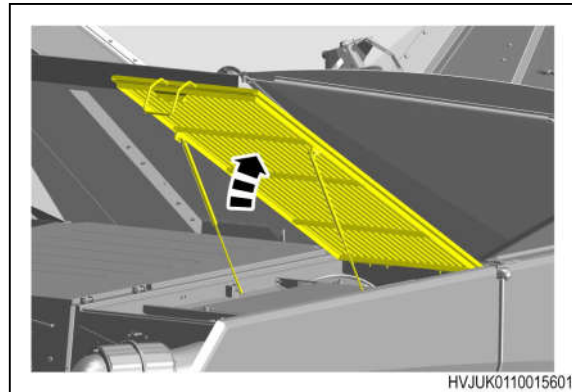

Fig. 172

3.10.22 Close the radiator screen cover



WARNING: The machine can move without warning.

The machine is heavy and can cause death or injury.

Park the machine on a clean, hard and level area. Set the parking brake to ON and install the wheel chocks.



WARNING: The machine has parts that move without operator input.

The parts that move can hit persons.

Stop the engine on the machine and remove the ignition key.



WARNING: Falling off, or into the machine.

Falls from height cause death or injury.

Use the applicable access equipment when you do work at height.

Procedure

1. Close the cover.

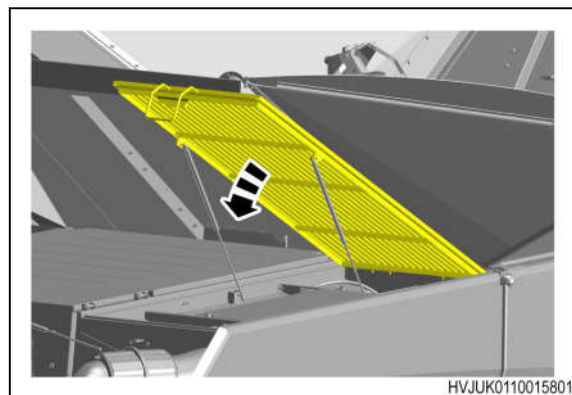
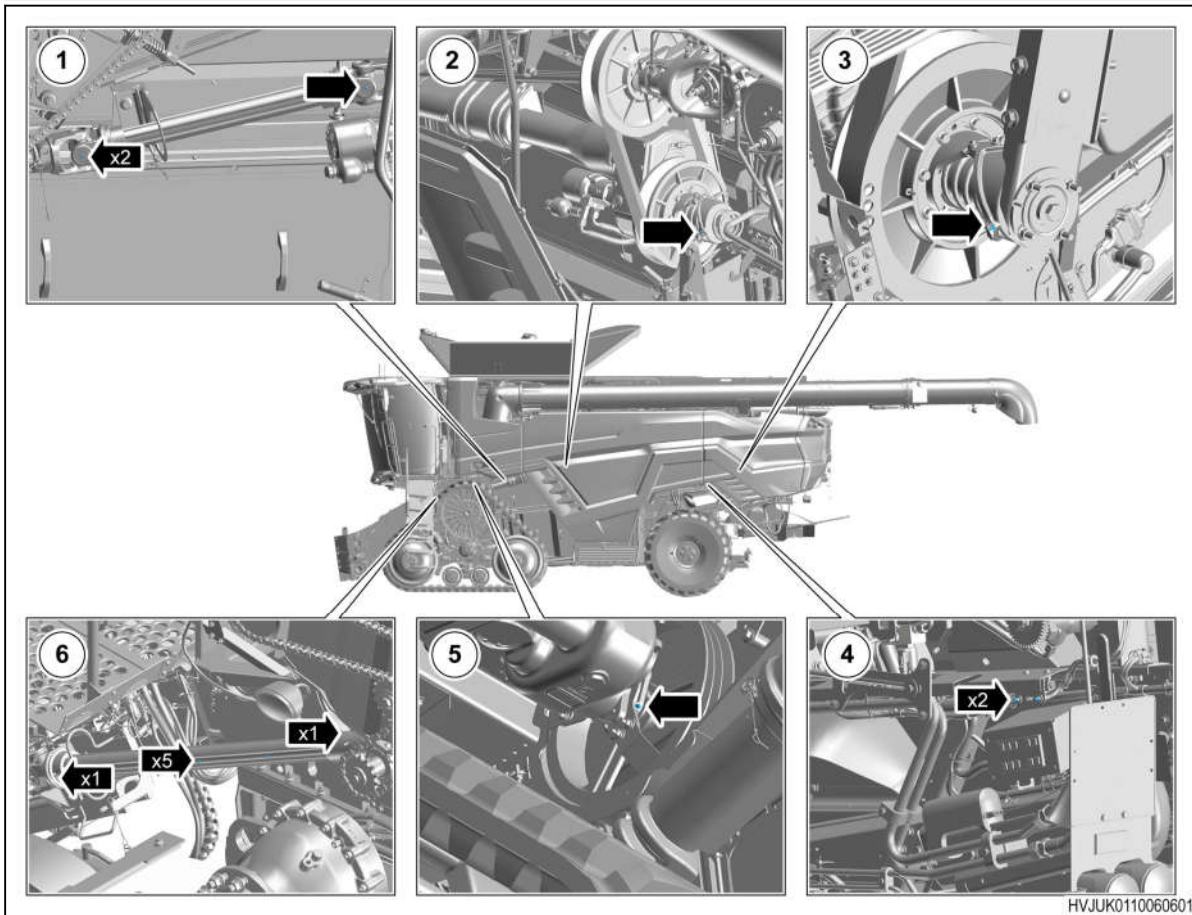

Fig. 173

4.4.6.6	Install the fan belt	505
4.4.6.7	Remove the engine belt - AP engine	505
4.4.6.8	Install the engine belt - AP engine	506
4.4.6.9	Remove the generator and AC compressor belt - AP engine	506
4.4.6.10	Install the generator and AC compressor belt - AP engine	507
4.4.6.11	Remove the coolant pump belt - AP engine	507
4.4.6.12	Install the coolant pump belt - AP engine	508
4.4.6.13	Remove the engine belt - MAN engine	508
4.4.6.14	Install the engine belt - MAN engine	509
4.4.7	DriveCenter	510
4.4.7.1	Examine the oil level in the DriveCenter	510
4.4.7.2	Change the oil in the DriveCenter	511
4.4.8	Engine cooling system	513
4.4.8.1	Engine cooling fan - adjustable blade angle	513
4.4.8.2	Engine coolant system	514
4.4.8.3	Do a check of the coolant level	514
4.4.8.4	Coolant mixture	515
4.4.8.5	Change the engine coolant	515
4.4.9	Drive belts and chains	517
4.4.9.1	Roller chain maintenance	517
4.4.9.2	Belt inspection and storage	518
4.4.9.3	Belt installation	518
4.4.9.4	Maintenance of chains	518
4.4.9.5	Variator belt storage	521
4.4.9.6	Machine drives	523
4.4.9.7	Belt adjustments	524
4.4.9.8	Adjust the belt for the cleaning sieve frame	525
4.4.9.9	Adjust the straw chopper belt	527
4.4.10	Axles	528
4.4.10.1	Adjust the rear axle tread width	528
4.4.10.2	Adjust the rear axle tread width for the rear wheel assist	531
4.4.10.3	Adjust the wheel alignment, rear wheel assist	536
4.4.10.4	Adjust the axle stop for the rear wheel assist	537
4.4.10.5	Adjust the steering cylinder limit	538
4.4.10.6	Do a check of the hub oil level, rear wheel assist axle	538
4.4.10.7	Replace the oil in the rear hub - machines with rear wheel assist	539
4.4.10.8	Do a check of the differential oil level, rear wheel assist	540
4.4.10.9	Replace the oil in the differential, rear wheel assist	541
4.4.11	Tracks	542
4.4.11.1	Tracks and undercarriage inspection	542
4.4.11.2	Align the track	545
4.4.11.3	Do a track alignment check	545
4.4.11.4	Adjust the track alignment	546
4.4.11.5	Adjust the drive wheel scraper	547
4.4.11.6	Do a check of the center pivot oil level	548
4.4.11.7	Replace the oil in the center pivot	548
4.4.11.8	Do a check of the idler hub oil level	550
4.4.11.9	Replace the idler hub oil	552
4.4.11.10	Do a check of the middle roller hub oil level	554
4.4.11.11	Replace the oil in the middle roller hub	556
4.4.11.12	Release the tension of the tracks	558
4.4.11.13	Adjust the tension of the tracks	561
4.4.11.14	Pressurize a suspension cylinder	565
4.4.11.15	Release the pressure from a cylinder	569
4.4.11.16	Remove the track	572
4.4.11.17	Install the track	576
4.4.11.18	Remove the undercarriage	579
4.4.11.19	Install the undercarriage	581

4.2.3 Lubrication points for the drives



HVJUK0110060601

Fig. 3

Location	Description
1	Top driveshaft for the header
2	Bottom variator pulley for the header
3	Bottom variator pulley for the rotor
4	Countershaft for the straw chopper
5	Pulley hub for the unloading auger
6	Bottom driveshaft for the header

[Maintenance schedule](#) page 427

4.3.6.1 Prepare for operation after storage



WARNING: The machine can move without warning.

The machine is heavy and can cause death or injury.

Park the machine on a clean, hard and level area. Set the parking brake to ON and install the wheel chocks.



WARNING: The machine has parts that move without operator input.

The parts that move can hit persons.

Stop the engine on the machine and remove the ignition key.

NOTE: *You must refer to the necessary procedures in this operator's manual.*

Procedure

1. Examine each belt on the machine and adjust to the correct tension.
2. Install the chains. Examine the chain alignment and the tensioners.
3. Do a check of the fluid levels. Examine for leaks.
4. Fill the Diesel exhaust fluid (DEF) tank.
5. Examine the air-conditioning window for bubbles. Fill if necessary.
6. Close the grain doors, the elevator doors and the stone trap.
7. Do a check of the tire pressures.
8. Do a check that all the shields, covers, access doors and guards are correctly installed.
9. **NOTE:** *This step is not necessary if the machine is stored in a building.*
Remove the spacer from the variator belt.

Related Links

[Lubrication specifications](#) page 728

[Belt inspection and storage](#) page 518

[Maintenance of chains](#) page 518

[Variator belt storage](#) page 521

[Battery main switch](#) page 634

[Close the elevator access door](#) page 372

[Stone trap](#) page 369

[Close the stone trap door](#) page 370

[Close the grain tank extensions](#) page 379

[Belt adjustments](#) page 524

[Maintenance schedule](#) page 427

- 20. Remove the oil filler cap and add the specified quantity of oil.

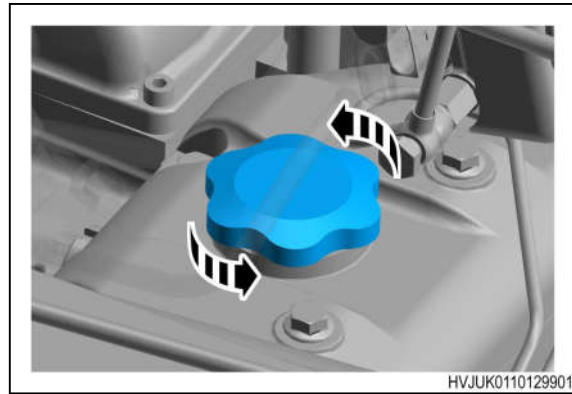

Fig. 49

- 21. Remove the dipstick and do a check of the oil level. The oil level must be between the applicable marks.
- 22. Start the engine.
- 23. Do a check for leaks.
- 24. Stop the engine and remove the ignition key.
- 25. Wait for 2 minutes for the oil level to become stable.
- 26. **NOTE:** *Do not add too much oil.*
Do a check of the oil level. If it is necessary, add more oil.
- 27. Install the steps and the 2 fasteners.

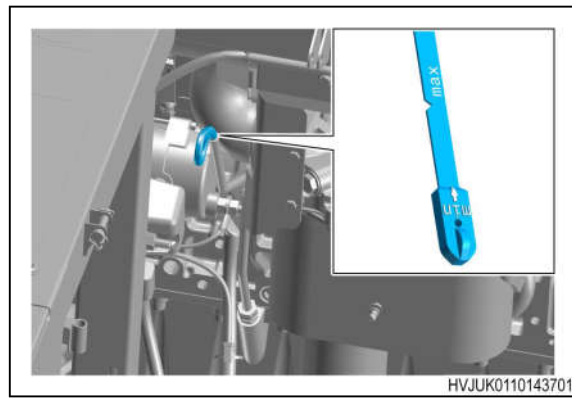

Fig. 50

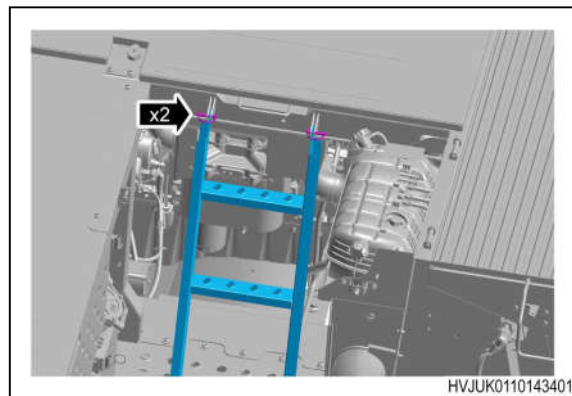

Fig. 51

4.4.2.3 Replace the primary air filter for the engine



WARNING: The machine can move without warning.

The machine is heavy and can cause death or injury.

Park the machine on a clean, hard and level area. Set the parking brake to ON and install the wheel chocks.



WARNING: The machine has parts that move without operator input.

The parts that move can hit persons.

Stop the engine on the machine and remove the ignition key.



WARNING: Falling off, or into the machine.

Falls from height cause death or injury.

Use the applicable access equipment when you do work at height.



CAUTION: PPE is mandatory.

This procedure can cause injury.

Put on Personal Protective Equipment (PPE) when you do this procedure.

Procedure

1. Open the right rear shield.
2. Use the ladder to get access to the engine platform.
3. Clean the external parts of the air filter housing.
4. Disconnect the 6 latches (3) on the air filter assembly.
5. Remove the cover (2) from the air filter assembly.
6. Remove the primary filter cartridge (1).
7. Examine the inner part of the filter housing for contamination. Clean the air filter housing if it is necessary.
8. Install the new primary filter cartridge (1).
9. Install the cover (2) on the filter assembly and attach the 6 latches (3).
10. Stow the ladder.
11. Close the right rear shield.
12. Do a check of the operation of the machine.

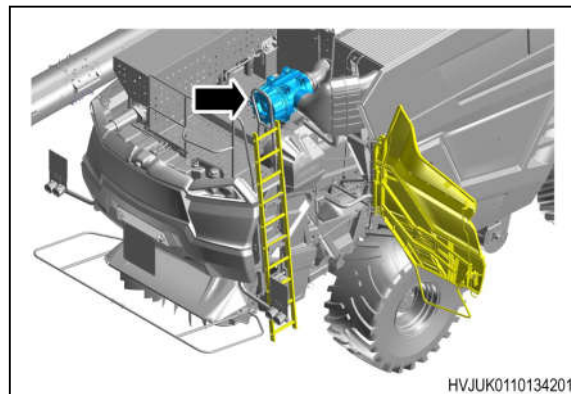

Fig. 83

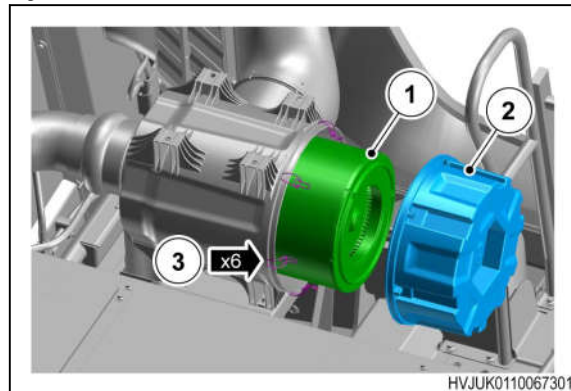

Fig. 84

Related Links

- 17. Stow the handrail.

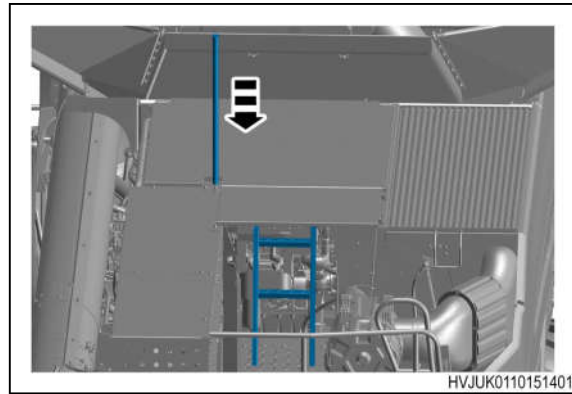

Fig. 108

- 18. Close the top rear engine cover and install the fastener.

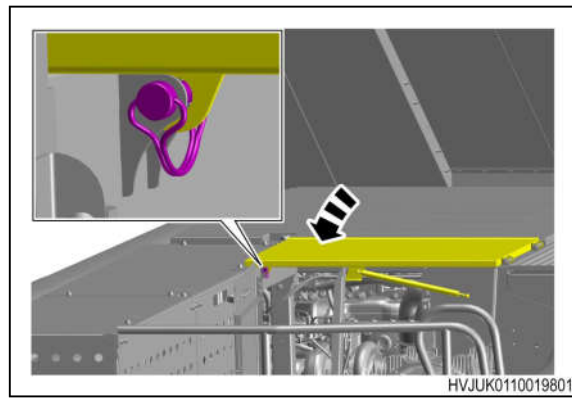

Fig. 109

- 19. Close the rear cover and install the fastener.

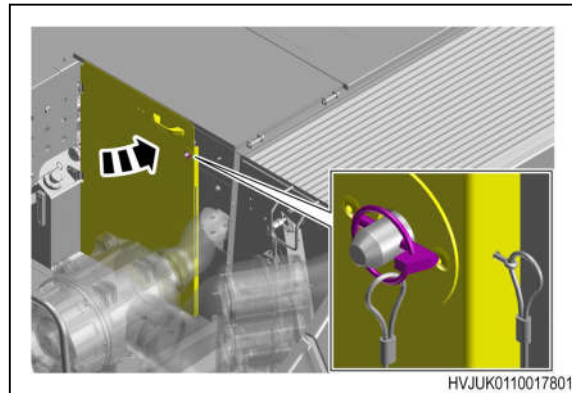

Fig. 110

- 20. Put the ladder in the storage position.

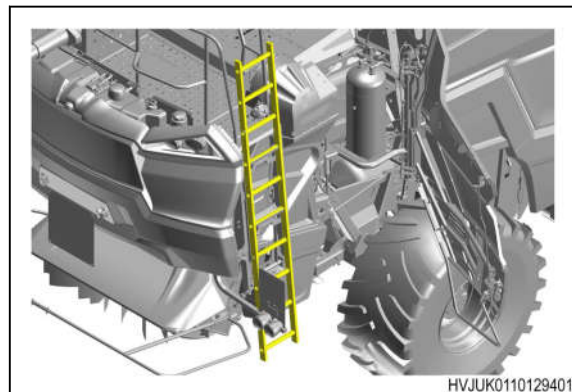
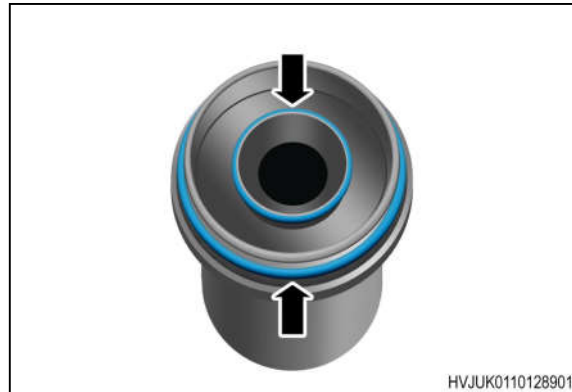

Fig. 111

17. Lubricate the filter seal with clean fuel.



HVJUK0110128901

Fig. 140

18. Install the filter.

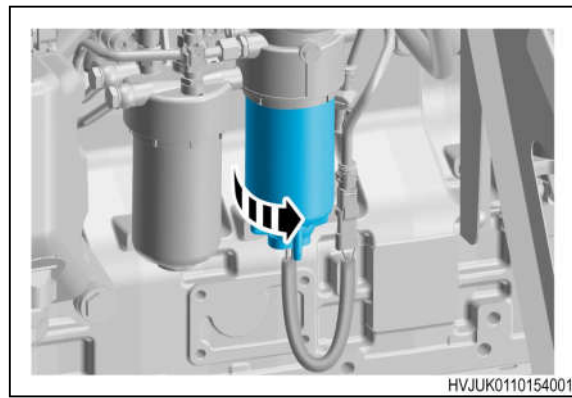

HVJUK0110154001

Fig. 141

19. Use the special tool (V837079717), to tighten the filter until the filter flange seals tightly against the filter head.

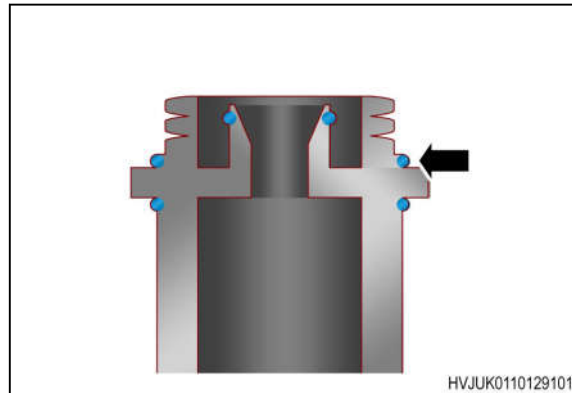

HVJUK0110129101

Fig. 142

20. Connect the electrical connector for the water detector.

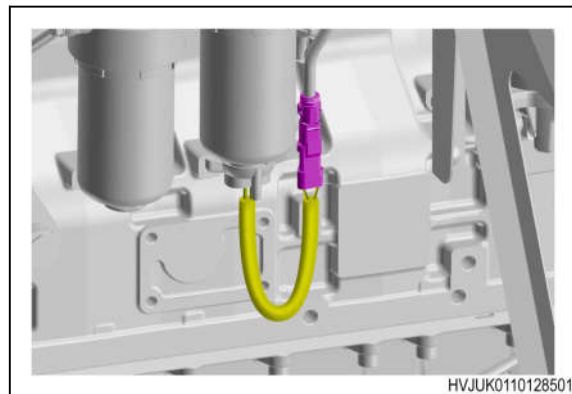

HVJUK0110128501

Fig. 143



WARNING: The machine has parts that move without operator input.

The parts that move can hit persons.

Stop the engine on the machine and remove the ignition key.



WARNING: Falling off, or into the machine.

Falls from height cause death or injury.

Use the applicable access equipment when you do work at height.



CAUTION: PPE is mandatory.

This procedure can cause injury.

Put on Personal Protective Equipment (PPE) when you do this procedure.



CAUTION: Damage to the environment.

Risk of damage to the environment if you incorrectly discard waste materials.

Obey the local regulations when you dispose of waste material.

IMPORTANT: All components of the fuel system must be kept clean from contamination. Do not let dust and dirt enter the fuel system.

Procedure

1. Open the right rear shield.

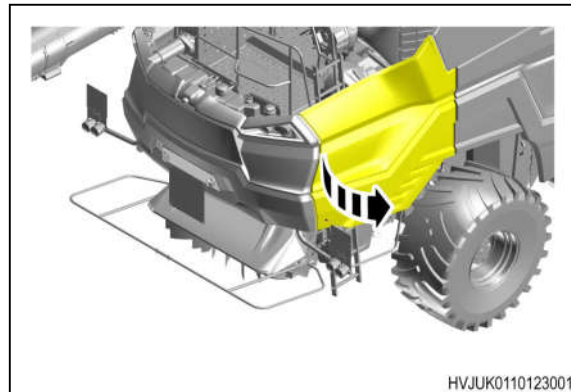

Fig. 174

2. Use the ladder to get access to the rear platform.

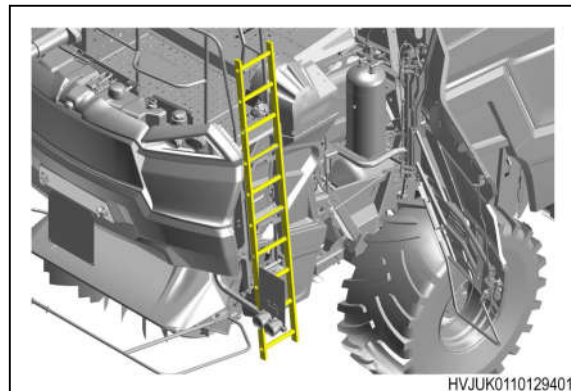

Fig. 175

Slowly release the tensioner (2) counterclockwise to apply tension to the aspirator pump belt (1). Remove the applicable tool from the tensioner (2).

5. **NOTE:** Do not try to install the fan belt (1) on to the tensioner pulley (2), until step 7.

Install the fan belt (1) on to the engine crankshaft pulley and the fan pulley.

6. Use an applicable tool to push down the fan belt tensioner (2).
7. Install the fan belt (1) on to the top of the fan belt tensioner (2).
8. **IMPORTANT:** To prevent damage to the belt, release the tensioner slowly.

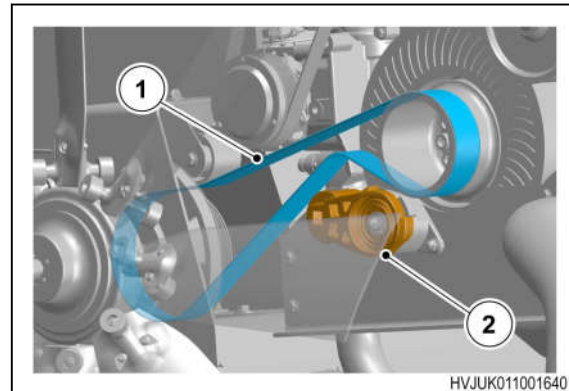

Fig. 197

Slowly release the fan belt tensioner (2), to apply tension to the fan belt (1). Remove the applicable tool from the fan belt tensioner (2).

9. **NOTE:** Remove all tools and equipment from the engine compartment before you set the engine to ON.

Set the engine to ON for a maximum of 1 minute and then set the engine to OFF.

10. Examine the installation of the belts and make sure that they are correct.
11. Close the engine covers.
12. Stow the ladder.
13. Close the right rear shield.

4.4.6.5 Remove the fan belt



WARNING: The machine can move without warning.

The machine is heavy and can cause death or injury.

Park the machine on a clean, hard and level area. Set the parking brake to ON and install the wheel chocks.



WARNING: The machine has parts that move without operator input.

The parts that move can hit persons.

Stop the engine on the machine and remove the ignition key.



WARNING: Falling off, or into the machine.

Falls from height cause death or injury.

Use the applicable access equipment when you do work at height.

Procedure

1. Open the right rear shield.
2. Use the ladder to get access to the engine platform.
3. Open the engine covers.

4.4.8.2 Engine coolant system

- (1) Breather pipes
- (2) Top hose
- (3) Radiator
- (4) Bottom hose
- (5) Reservoir hose
- (6) Coolant reservoir

The coolant in the engine is a mixture of water and antifreeze. The coolant gives protection to the engine at temperatures of more than -34°C .

The engine coolant is for all the year use of the machine.

NOTE: *The engine coolant also supplies the heat from the engine for the cab.*

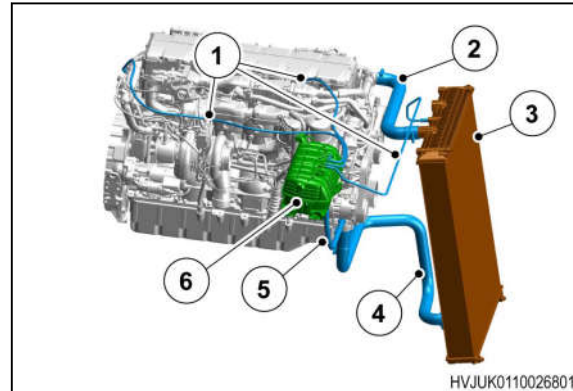

Fig. 218

4.4.8.3 Do a check of the coolant level



WARNING: The machine can move without warning.

The machine is heavy and can cause death or injury.

Park the machine on a clean, hard and level area. Set the parking brake to ON and install the wheel chocks.



WARNING: Hot components.

Risk of death or injury caused by burns.

Before you do work on the machine, stop the engine and remove the ignition key.

Let the temperature of the component decrease until it is the same as the ambient temperature.

To access the coolant reservoir:

1. Open the rear shield.
2. Use the ladder to get on the engine platform.
3. Open the engine cover.

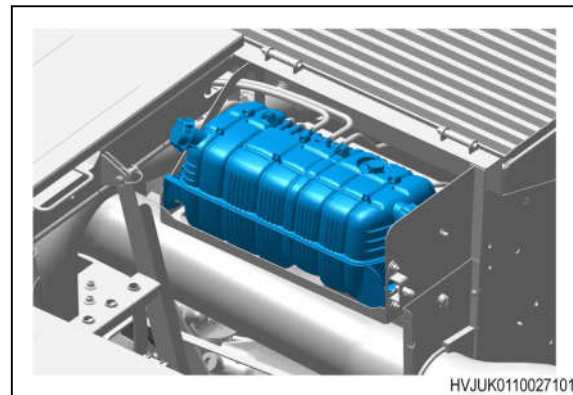

Fig. 219

- (3) Drive belt for the rotor mechanism, the straw chopper and the shaft to the right side
- (4) Drive for the rotor mechanism and the straw chopper
- (5) Primary drive belt for the shaft to supply drive to the right side for the:
 - Returns threshing unit
 - Grain elevator
- (6) Drive belt for the cleaning fan
- (7) Drive shaft for the header and feeder conveyor belt
- (8) Chain drive for the unloading auger/s in the bottom of the grain tank
 - Shaking unit for the bottom shaken sieve frame.

4.4.9.7 Belt adjustments

Before starting the procedure



WARNING: The machine can move without warning.

The machine is heavy and can cause death or injury.

Park the machine on a clean, hard and level area. Set the parking brake to ON and install the wheel chocks.



WARNING: The machine has parts that move without operator input.

The parts that move can hit persons.

Stop the engine on the machine and remove the ignition key.



WARNING: Falling off, or into the machine.

Falls from height cause death or injury.

Use the applicable access equipment when you do work at height.

Procedure

1. Open the shields that are necessary to access the belt adjustment/s.
2. Examine the condition of the belt. Replace the belt, if necessary.
3. Examine the tension on the belt. Make sure that the belt tensioner can move.
4. **NOTE:** *The example shown is a general illustration of the procedure.*

The tension is correct when you can see the spacer (1) through the indication hole (2).

- If you cannot see the spacer (1) through the indication hole (2), go to step 5.
- If you can see the spacer (1) through the indication hole (2), go to step 8.

5. Release the fastener (3).
6. Adjust the fastener (4) until you see the spacer (1) in the indication hole (2).
7. Tighten the fastener (3) against the fastener (4) to prevent movement.
8. Examine the tension on the belt. If the belt tension is not sufficient, replace the belt.
9. Close the shields.

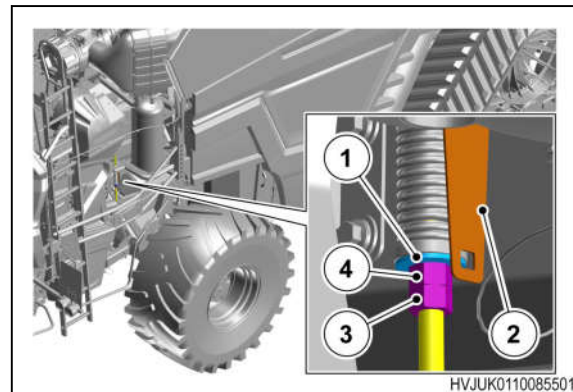

Fig. 233

11. Align the holes and install the 3 fasteners in the front of the axle. Tighten the 3 fasteners to a torque of 610 Nm.

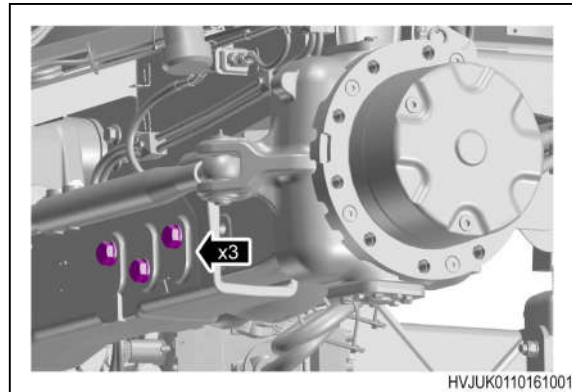

Fig. 264

12. Tighten the 3 studs to a torque of 200 Nm.

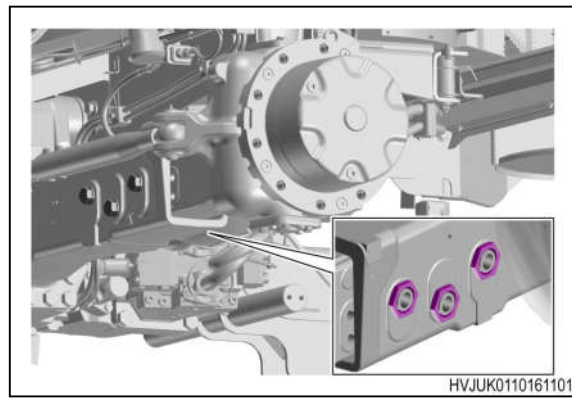

Fig. 265

13. Install the 3 fasteners in the rear of the axle. Tighten to a torque of 610 Nm.
14. Remove the lifting equipment from the end of the axle beam.

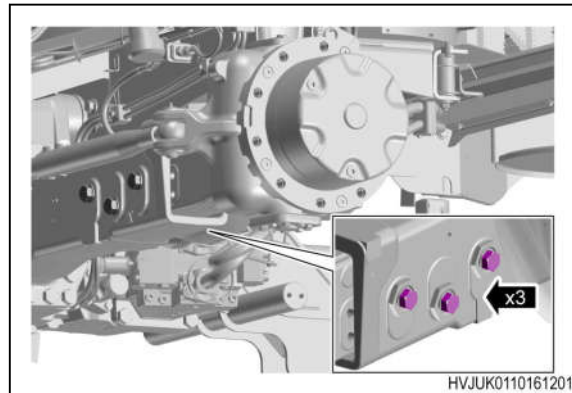

Fig. 266

15. Install the 2 fasteners in the tie rod. Tighten the 2 fasteners to a torque of 130 Nm.

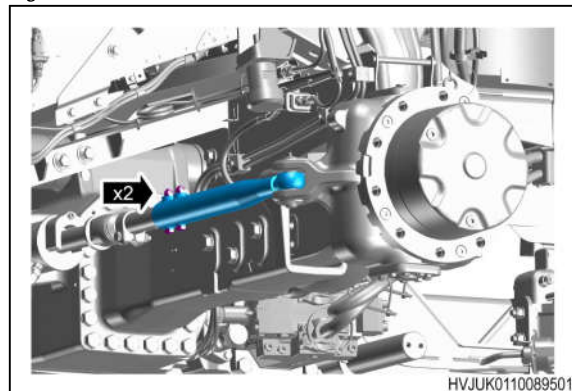

Fig. 267

- 5. Examine the roller wheels. If the roller wheels have less than 15 mm of tire depth remaining, or have damage replace them.

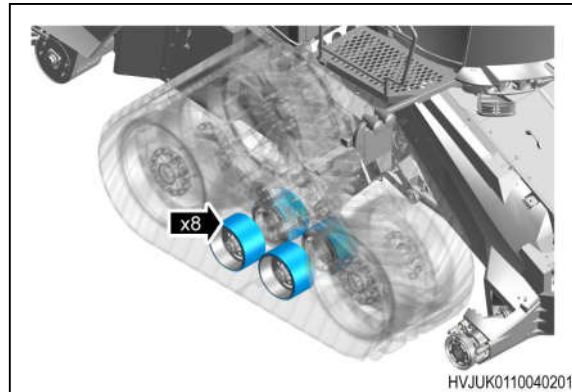

Fig. 287

- 6. Examine the idler wheels. If the idler wheels have less than 15 mm of tire depth remaining, or have damage replace them.

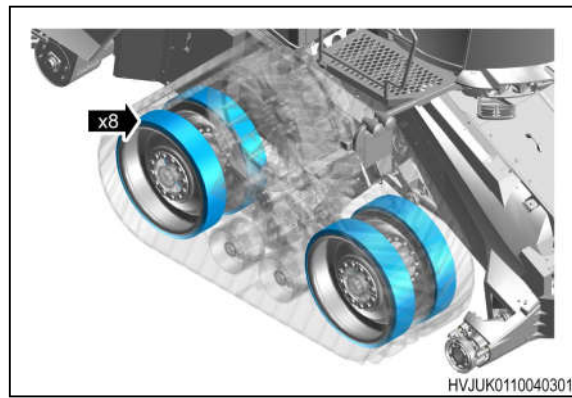

Fig. 288

- 7. Examine the guide rings on the middle rollers. If they are very worn or damaged, replace the parts and do a check of the track alignment.

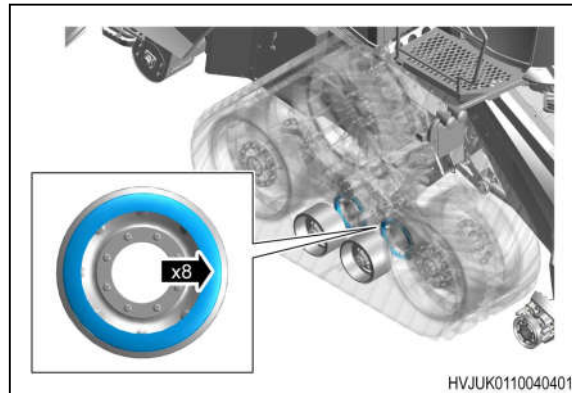

Fig. 289

- 8. Examine the undercarriage for oil leaks. Repair leaks and clean oil off immediately as oil will damage the tracks and tires.

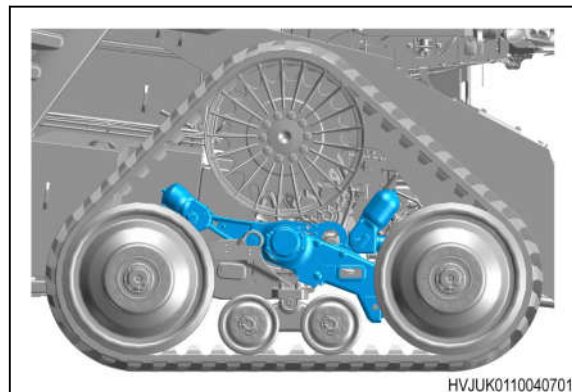

Fig. 290

- 15. NOTE:** The oil level is correct when it is in the top half of the sight glass.

Fill the hub with oil until the correct level is shown on the sight glass.

- 16.** Wait for 5 minutes for the oil to fill the space in the hub.
- 17.** Examine the oil level in the sight glass and add more oil if necessary.

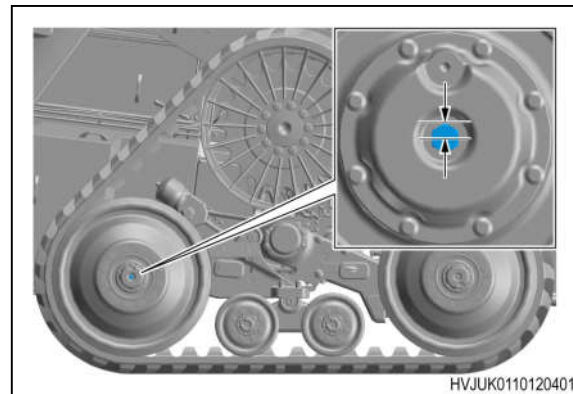

Fig. 314

- 18.** Install the plug and tighten to the standard torque.

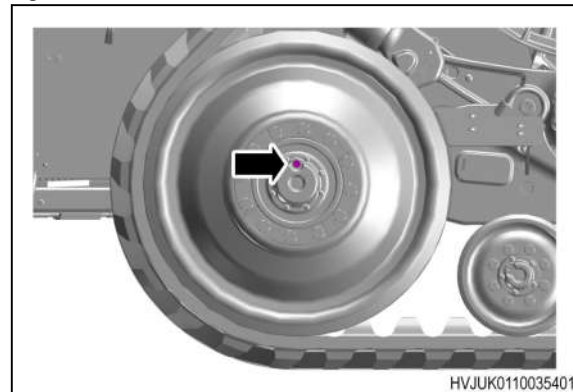

Fig. 315

Related Links

[Lubrication specifications](#) page 728

4.4.11.10 Do a check of the middle roller hub oil level



WARNING: The machine can move without warning.

The machine is heavy and can cause death or injury.

Park the machine on a clean, hard and level area. Set the parking brake to ON and install the wheel chocks.



WARNING: The machine has parts that move without operator input.

The parts that move can hit persons.

Stop the engine on the machine and remove the ignition key.

IMPORTANT: Some lubricants can cause damage to the tracks and tires. Clean the area of spilled oil immediately.

- 12. NOTE:** *The drain hose will release oil and air.*
Open the inlet valve 0.5 to 1 turn counterclockwise.

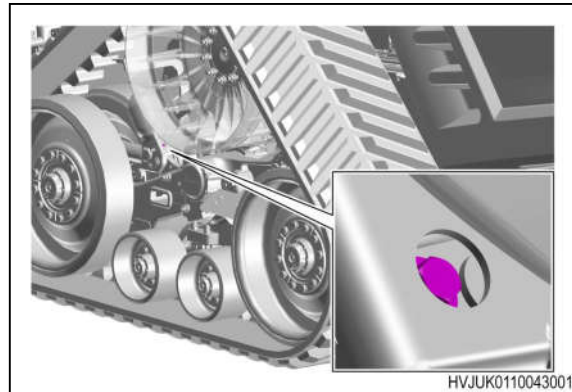

Fig. 342

- 13.** Let the oil flow until there are no air bubbles released from the drain hose (1).
14. Close the bleed valve (2), and tighten to a torque of 28 Nm.
15. Remove the container from the drain hose (1).

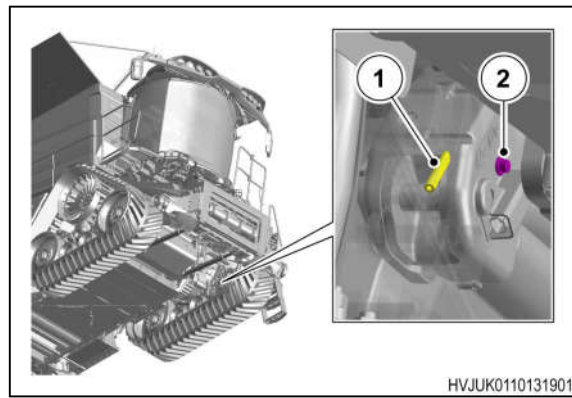

Fig. 343

- 16. NOTE:** *Push and hold the reel lift function on the multifunction control lever for full pressure. The cylinder will pressurize to 2900psi to 3000psi. The pressure will decrease by a small quantity after the operation.*
Fill the cylinder for a minimum of 2 minutes to pressurize to the correct level.

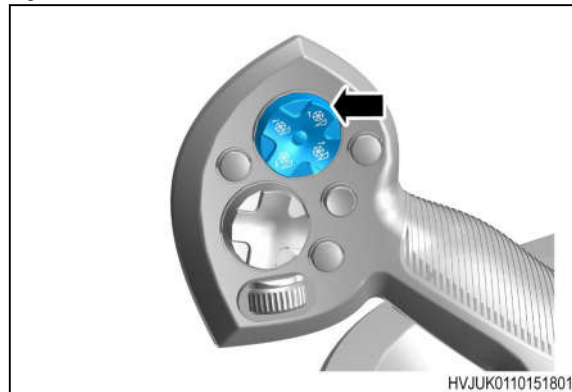

Fig. 344

- 17.** Keep full pressure and close the inlet valve (1). Tighten to a torque of 28 Nm.

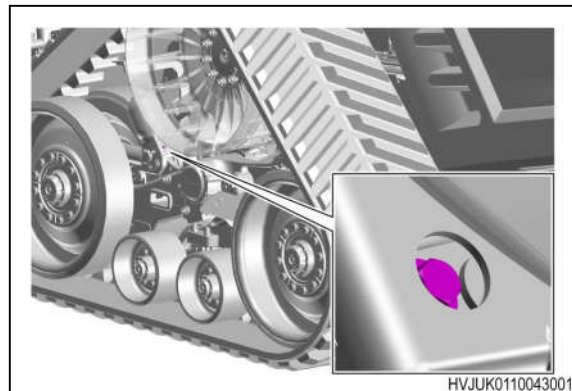

Fig. 345

9. **NOTE:** The header reverse manifold is above the batteries on the left side.

Clean the area around the diagnostic port on the header reverse manifold.

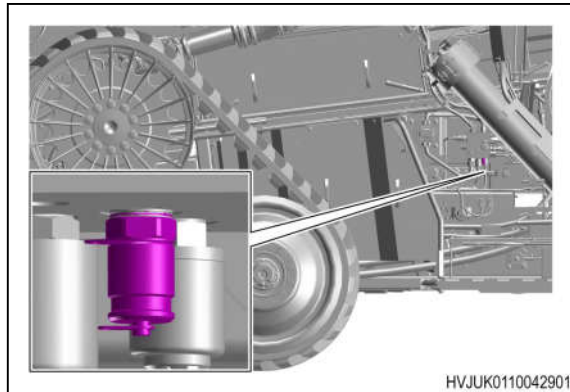

Fig. 374

10. Clean the area around the inlet union on the front cylinder.

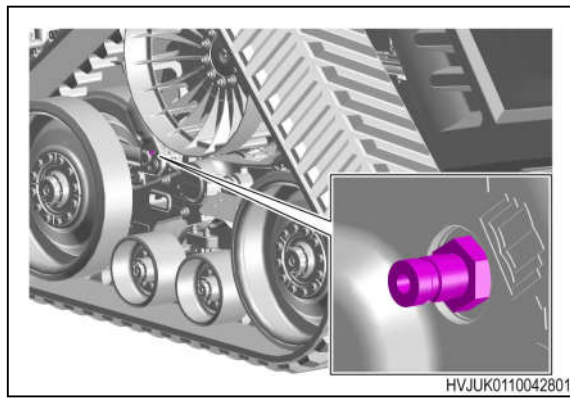

Fig. 375

11. **NOTE:** The track tension hose is stored in the tool box.

Connect the track tension hose to the inlet union on the front cylinder

12. Connect the other end of the hose to the diagnostic port on the header reverse manifold.

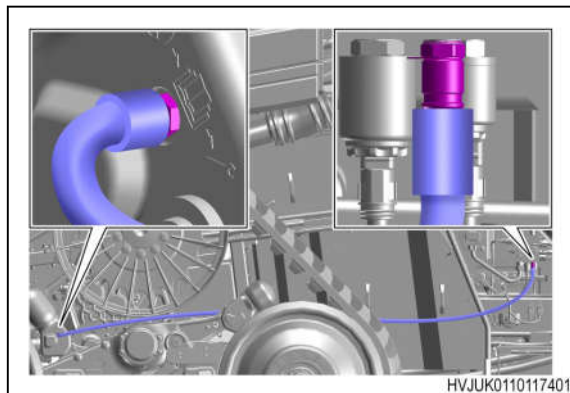

Fig. 376

13. Open the inlet valve to release the oil pressure in the cylinder.

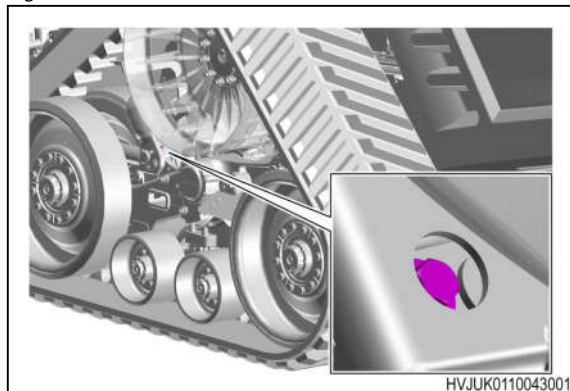

Fig. 377

Procedure

1. Lift the feeder housing.
2. Stop the engine on the machine and remove the ignition key.



Fig. 403

3. Engage the safety stop for the header lift cylinder.

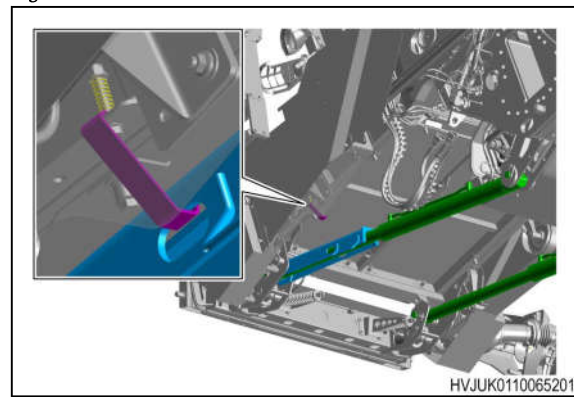

Fig. 404

4. **NOTE:** The bottom mark is the minimum oil level, the top mark is the maximum oil level.

Examine the oil level to make sure that it is at the correct level (A). If the oil level is not at the correct level (A), then adjust as necessary.

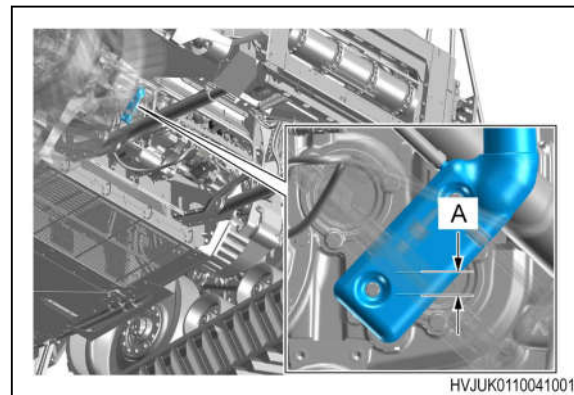

Fig. 405

21. Install the top transmission cover and the 4 fasteners, then tighten to the standard torque.

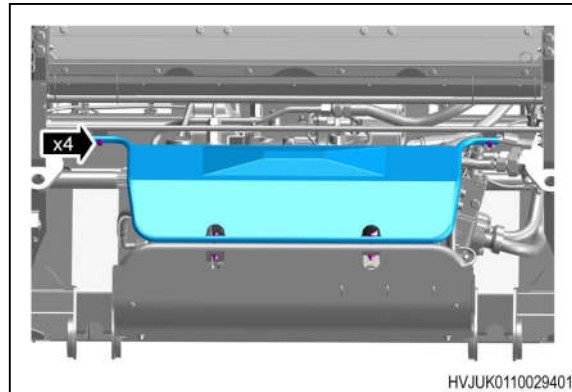

Fig. 434

22. Engage the bottom transmission cover in the 3 slots.
23. Install the 4 fasteners. Tighten to the standard torque.

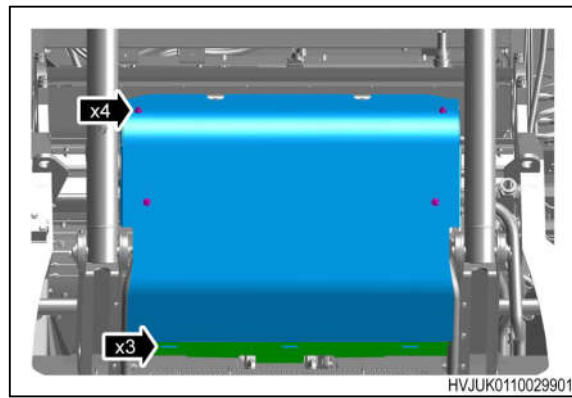

Fig. 435

24. Disengage the safety stop for the header lift cylinder.

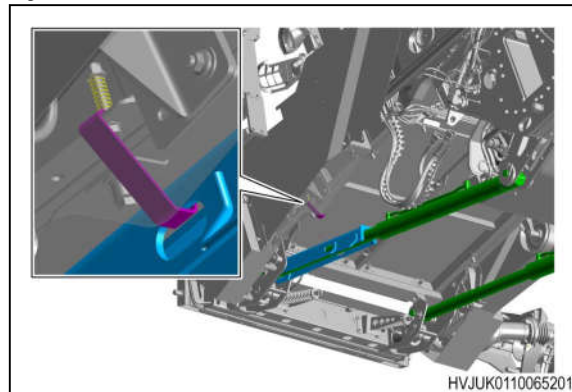

Fig. 436

25. Do a check that the machine operates correctly.

Related Links

[Maintenance schedule](#) page 427

4.4.12.4 Replace the gearbox breather



WARNING: The machine can move without warning.

The machine is heavy and can cause death or injury.

Park the machine on a clean, hard and level area. Set the parking brake to ON and install the wheel chocks.

2. Put a container in an applicable position to collect all fluids that come out during this procedure.
3. **NOTE:** *There are 2 level plugs. You must identify the final drive unit position and use the appropriate oil level plug.*

Clean the oil level plug and the adjacent area.

4. **NOTE:** *If the final drive is installed in the low position, use the top level plug (1). If the final drive is mounted in the high position use the bottom level plug (2).*

Remove the appropriate oil level plug from the final drive. If oil does not come out of the hole, you must add oil to the final drive.

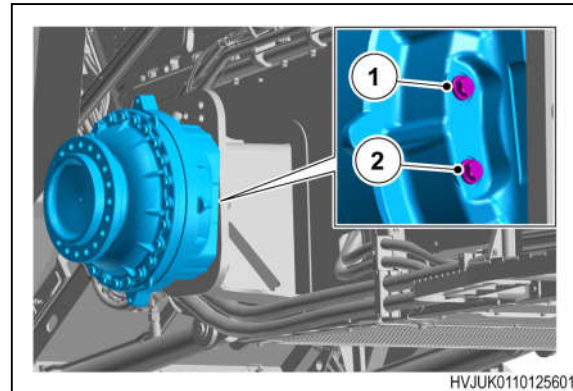

Fig. 464

5. Remove the breather from the top of the final drive.
6. Add the correct specification of oil to the final drive in the breather hole. Fill the final drive with oil to the bottom of the oil level plug hole.
7. Install the oil level plug and tighten to the standard torque.
8. Install the breather and tighten to the standard torque.
9. Install the front wheel.

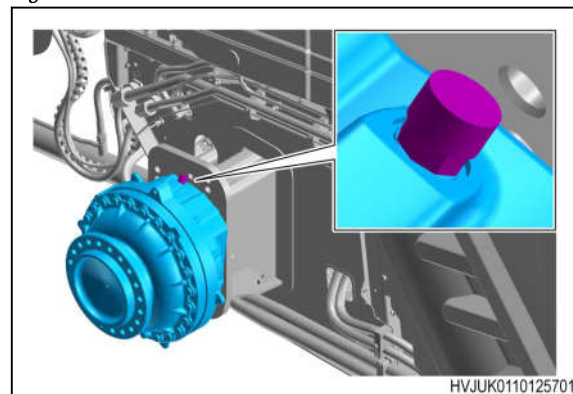

Fig. 465

4.4.13.2 Replace the final drive oil - machines with wheels



WARNING: The machine can move without warning.

The machine is heavy and can cause death or injury.

Park the machine on a clean, hard and level area. Set the parking brake to ON and install the wheel chocks.



WARNING: The machine has parts that move without operator input.

The parts that move can hit persons.

Stop the engine on the machine and remove the ignition key.



DANGER: Falling components.

The machine can fall and cause death or injury if you do not use the supports.

Make sure that you use lift equipment specified for the weight of the machine.

When you lift the machine, put the supports in the correct positions.



CAUTION: Damage to the environment.

Risk of damage to the environment if you incorrectly discard waste materials.

Obey the local regulations when you dispose of waste material.

IMPORTANT:

Use the applicable containers to collect waste fluids and clean spills immediately. Obey local regulations for larger spills that can cause damage to the environment.

- 21. Set the access ladder to the bottom position to get access to the rear platform.

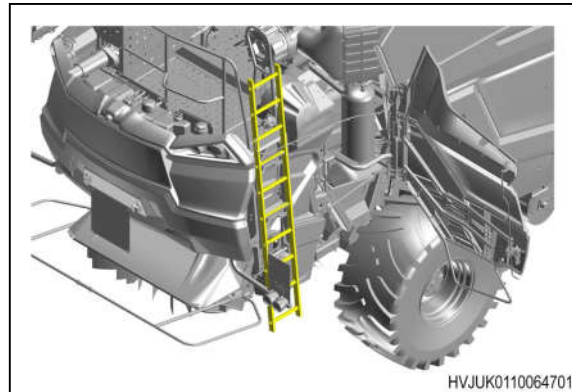

Fig. 492

- 22. **NOTE:** Two rotor versions have two dipsticks, one rotor versions have one dipstick.

Clean the area around the dipstick.

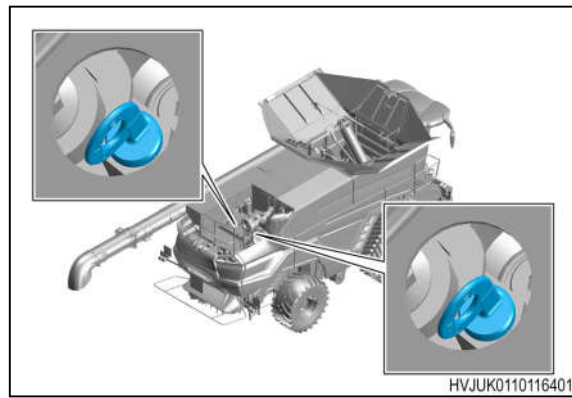

Fig. 493

- 23. Remove the dipstick and add the correct quantity of the specified oil through the dipstick tube.
- 24. Make sure that the oil level aligns to the maximum level mark on the dipstick.

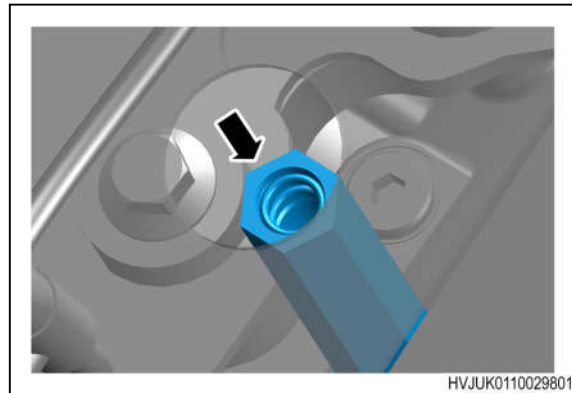

Fig. 494

- 25. Stow the ladder.

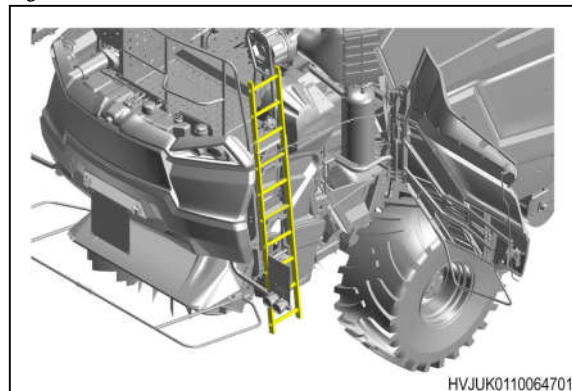

Fig. 495

8. **NOTE:** If it is not possible to release the brakes with step 6:

Loosen the locknut and the adjustment nut on the brake cable sufficiently to release the pressure on the brake actuators.

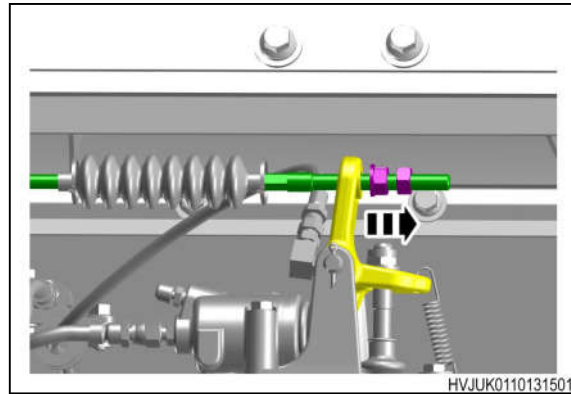

Fig. 521

4.4.17 Hydraulic system

4.4.17.1 Do a check of the hydraulic oil level



WARNING: The machine can move without warning.

The machine is heavy and can cause death or injury.

Park the machine on a clean, hard and level area. Set the parking brake to ON and install the wheel chocks.



WARNING: The machine has parts that move without operator input.

The parts that move can hit persons.

Stop the engine on the machine and remove the ignition key.



WARNING: Falling off, or into the machine.

Falls from height cause death or injury.

Use the applicable access equipment when you do work at height.

IMPORTANT:

Use the correct type and quantity of lubricants. If you do not, you can cause damage to the machine.

Procedure

1. Lower the feeder unit to the ground.
2. Close the grain tank extensions.
3. Put the unloading auger in the stowed position.
4. Open the right rear shield.
5. Use the engine platform ladder to get on the engine platform.
6. Look at the sight glass (2) on the hydraulic oil tank. The oil level must be at 2/3 on the sight glass.
7. If the hydraulic oil level is below 2/3 on the sight glass you must add hydraulic oil to the tank. Remove the cap (1), add oil to the tank and install the cap (1).
8. Put the engine platform ladder in the storage position.
9. Close the right rear shield.

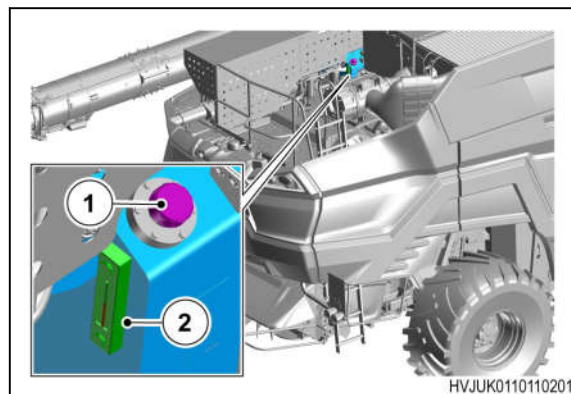

Fig. 522

4.4.17.6 Hydrostatic oil cooler

The hydrostatic oil cooler is adjacent to the cooling fan, on the rear right side of the machine.

The hydrostatic oil cooler keeps the hydraulic oil at the correct temperature. This makes sure that the components in the hydraulic system operate for the best possible performance.

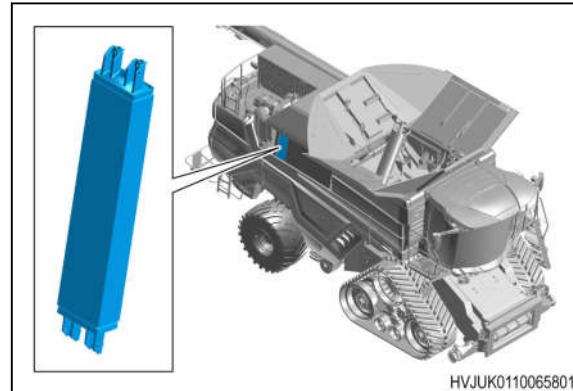

Fig. 546

4.4.18 Electrical system**4.4.18.1 Battery**

The batteries are in the battery compartment. The battery compartment is in front of the rear axle, on the left side of the machine.

The battery compartment contains 4 batteries. Each battery is 12 V.

4.4.18.2 Battery main switch

The battery main switch is on the left side of the machine, at the rear of the battery compartment.

The battery main switch connects the battery positive supply to the main circuit fuses.

To set the 12 V supply to ON, turn the battery main switch clockwise to the ON position.

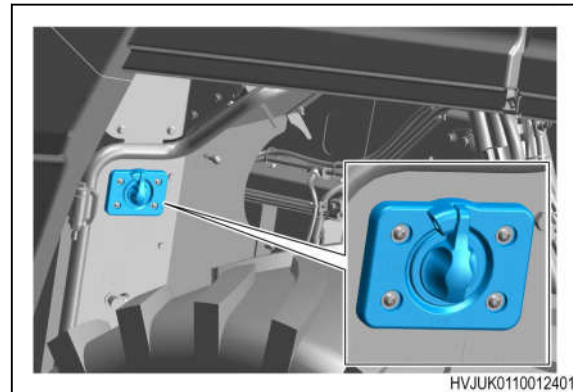

Fig. 547

4.4.18.3 Access the batteries

WARNING: The machine can move without warning.

The machine is heavy and can cause death or injury.

Park the machine on a clean, hard and level area. Set the parking brake to ON and install the wheel chocks.



WARNING: The machine has parts that move without operator input.

The parts that move can hit persons.

Stop the engine on the machine and remove the ignition key.



WARNING: The machine has parts that move without operator input.

The parts that move can hit persons.

Stop the engine on the machine and remove the ignition key.

Procedure

1. Disconnect the electrical connector (2).
2. Remove the 3 fasteners (1).
3. Remove the head lamp assembly (3).
4. Install the replacement head lamp assembly (3) in position.
5. Install the 3 fasteners (1).
6. Connect the electrical connector (2).
7. Align the head lamp.

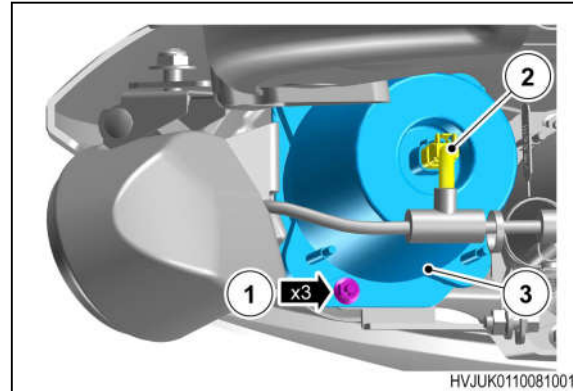

Fig. 568

4.4.18.12 Adjust the cab lamps

Before starting the procedure



WARNING: The machine can move without warning.

The machine is heavy and can cause death or injury.

Park the machine on a clean, hard and level area. Set the parking brake to ON and install the wheel chocks.



WARNING: The machine has parts that move without operator input.

The parts that move can hit persons.

Stop the engine on the machine and remove the ignition key.



WARNING: Falling off, or into the machine.

Falls from height cause death or injury.

Use the applicable access equipment when you do work at height.

Procedure

1. **Align the cab lamp vertically**
 - a) Loosen the fastener (2).
 - b) Align the vertical position of the cab lamp to illuminate the necessary area.
 - c) Tighten the fastener (2) to the standard torque.

2. **NOTE: To adjust the cab lamp horizontally you must remove the roof front cover.**

Align the cab lamp horizontally

- a) Loosen the fastener (1).
- b) Align the horizontal position of the cab lamp to illuminate the necessary area.
- c) Tighten the fastener (1) to the standard torque.

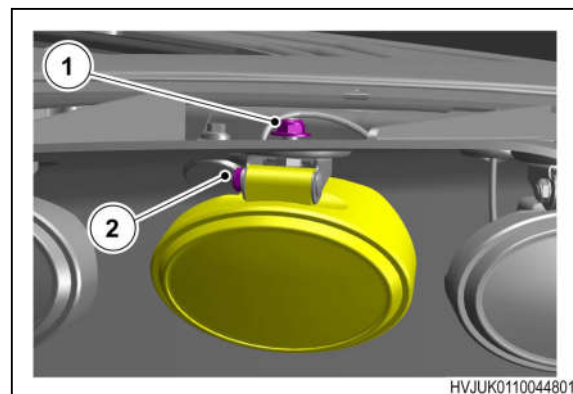

Fig. 569

Fuses

Position	Amperage (A)	Function
F1	25	Unloader fold actuator - retract (auger extend)
F2	25	Unloader fold actuator - extend (auger stow)
F3	5	Grain quality sensor (GQS)/Mass and distribution sensor (MADS) (ignition ON)
F4	10	Device supply (ignition ON)
F5	30	Header actuators - retract (reel in/deckplate close/drapper speed retract)
F6	30	Header actuators - extend (reel out/deckplate open/drapper speed extend)
F7		Not used
F8		Not used
F9	5	Proportional valve digital (PVED) (steering cutoff relay)
F10	10	Fuel pump
F11	5	Grain tank inspection lamp
F12	5	Unloader auger lamps
F13	15	Sensors (ignition ON)
F14	10	Ground drive module (GDM) (ignition ON)
F15	5	Sensors (ignition ON)
F16	20	VMM1 controller (unswitched)
F17	30	EXT controller (unswitched)

Relays

Position	Function
K1	Unloader fold actuator - retract (auger extend)
K2	Unloader fold actuator - extend (auger stow)
K3	Grain quality sensor (GQS)/Mass and distribution sensor (MADS) (ignition ON)
K4	Device supply (ignition ON)
K5	Header actuators - retract (reel in/deckplate close/drapper speed retract)
K6	Header actuators - extend (reel out/deckplate open/drapper speed extend)
K7	Not used
K8	Not used
K9	Not used
K10	Fuel pump
K11	Grain tank inspection lamp
K12	Unloader auger lamps
K13	Ground drive module (GDM) and sensors (ignition ON)

- Engage the safety stop for the header lift cylinder.

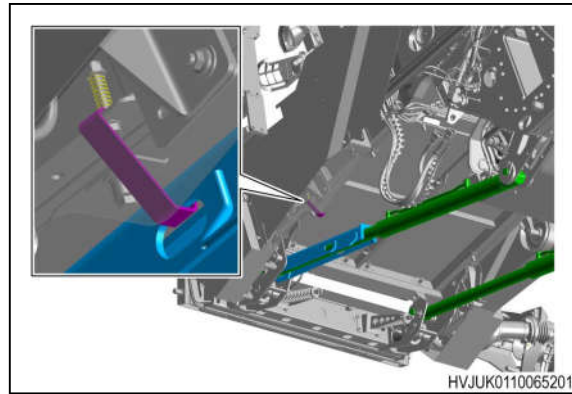



Fig. 596

- NOTE:** Identify the lifting points with the  decals on the machine.

Install the lifting equipment on the applicable side.

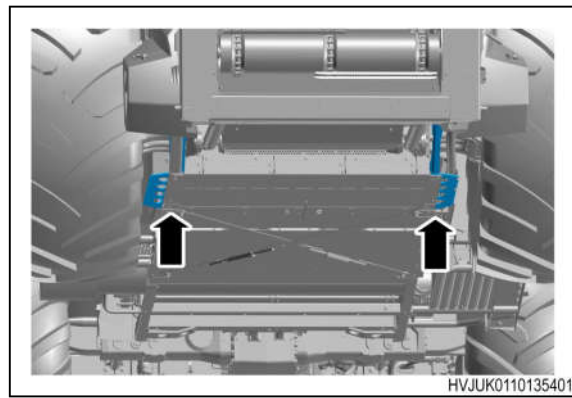

Fig. 597

- Loosen the 10 fasteners half a turn counterclockwise.

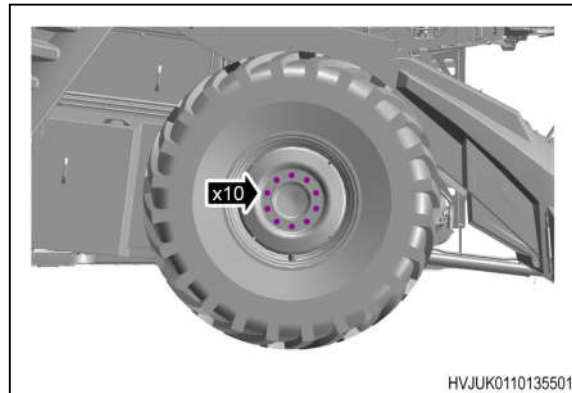

Fig. 598

- Lift the machine until the wheel is off the ground.
- Install an axle support below the machine to hold it in position.

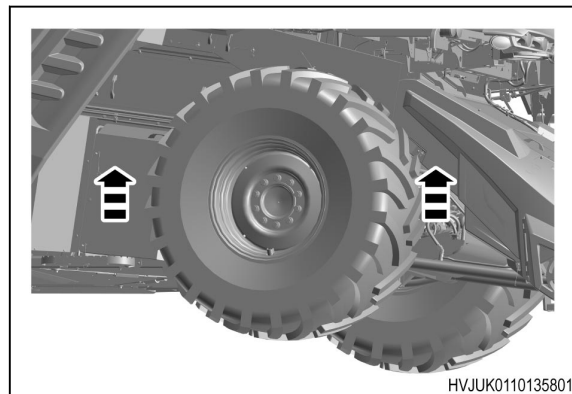

Fig. 599

4. Maintenance and lubrication

2. Clean the area around the gearbox fill plug (1), and the drain plug (2).
3. **NOTE:**
Put a container in an applicable position to collect all fluids that come out during the procedure.
Remove the fill plug (1) and the drain plug (2).

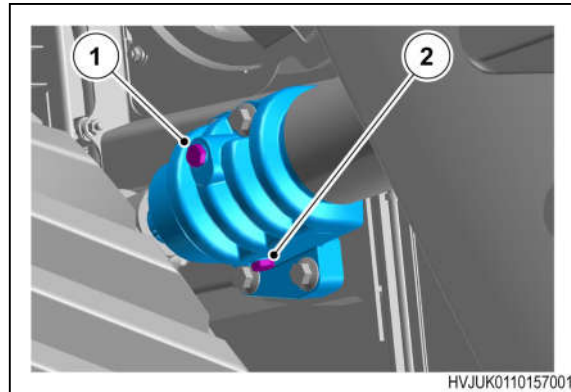

Fig. 623

4. Examine the seals on the plugs. Replace if necessary.

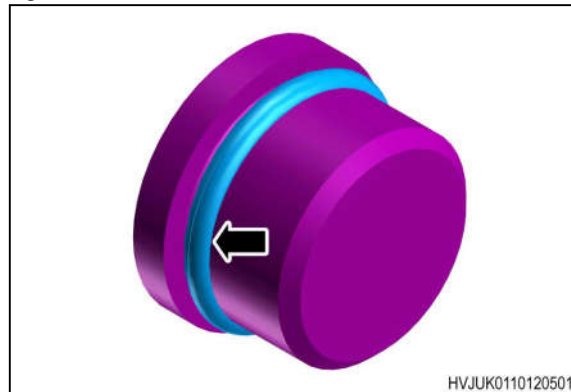

Fig. 624

5. When the gearbox is empty, install the drain plug (2), and tighten to a torque of 40 Nm.
6. **NOTE:** *The correct oil level is to the bottom of the fill hole (1).*
Fill the gearbox with the specified oil.
7. Install the fill plug (1) and tighten to a torque of 40 Nm.

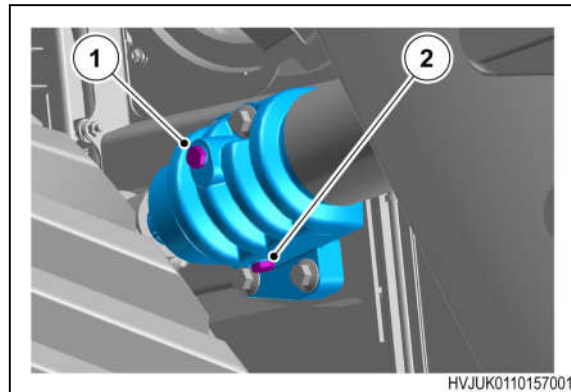

Fig. 625

8. Do a check of the operation of the machine.

Related Links

[Lubrication specifications](#) page 728

[Maintenance schedule](#) page 427

4.4.26.5 Do a check of the oil level in the bottom header drive gearbox



WARNING: The machine can move without warning.

The machine is heavy and can cause death or injury.

Park the machine on a clean, hard and level area. Set the parking brake to ON and install the wheel chocks.

4.4.28.3 Install the concaves

Procedure

1. To install the concave:
 - a) Engage the concave (1) on to the shaft (2).
 - b) Move the concave up.

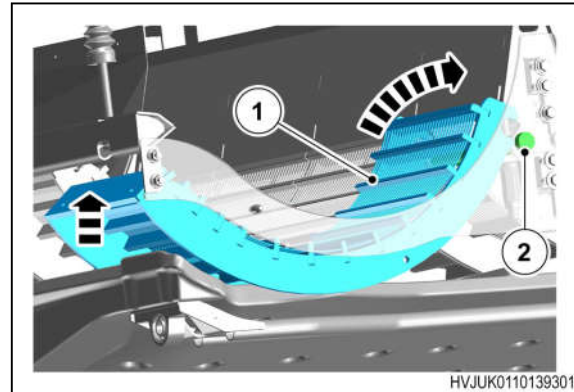

Fig. 642

2. Install the 2 fasteners and tighten to the standard torque.

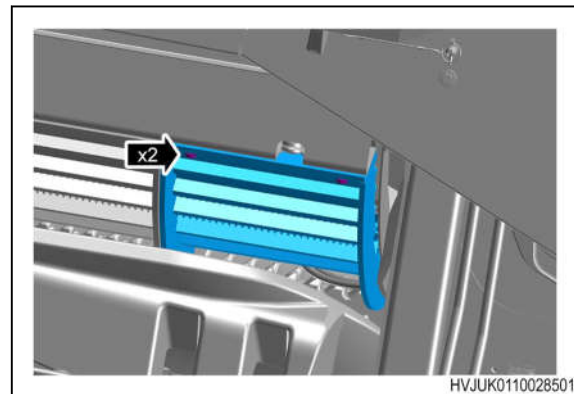

Fig. 643

3. To install the sensor assembly:
 - a) Hold the sensor in position.
 - b) Install the 2 fasteners and tighten to the standard torque.
 - c) Connect the electrical connector.
4. If necessary, install the front grain pan.

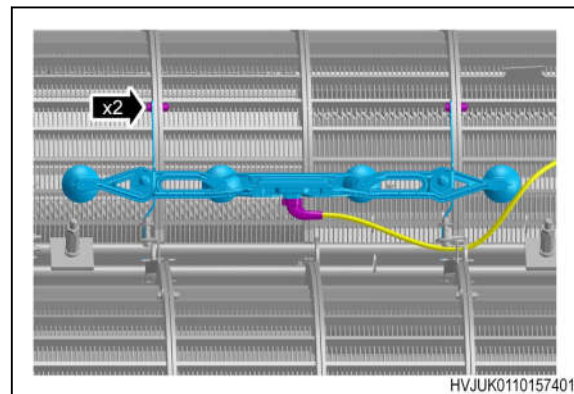

Fig. 644

3. Disconnect the electrical connector.

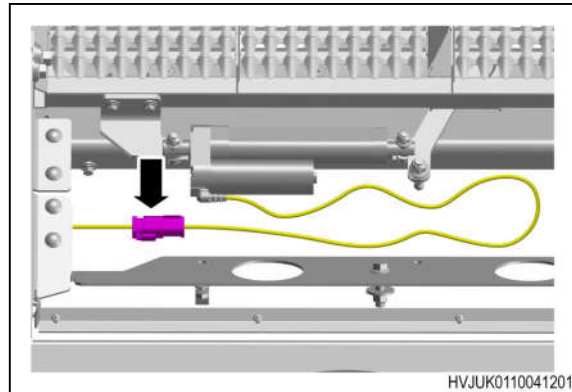

Fig. 676

4. Remove the 2 fasteners. Remove the sieve actuator.

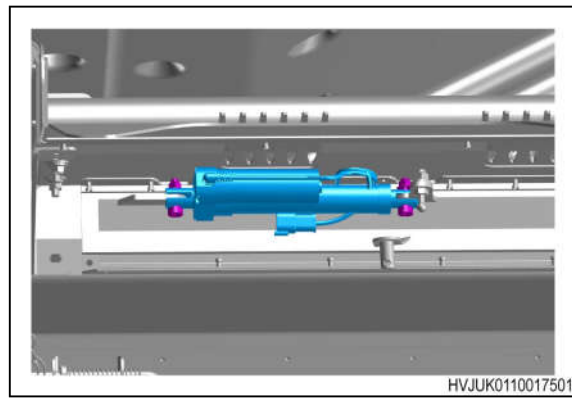

Fig. 677

5. Remove the 3 fasteners. Remove the sieves.

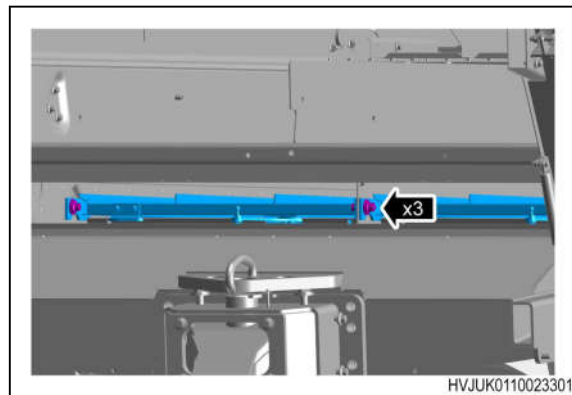

Fig. 678

Related Links

[Remove the top sieves](#) page 685

4.4.31.2 Replace the oil in the unloading auger bottom gearbox



WARNING: The machine can move without warning.

The machine is heavy and can cause death or injury.

Park the machine on a clean, hard and level area. Set the parking brake to ON and install the wheel chocks.



WARNING: The machine has parts that move without operator input.

The parts that move can hit persons.

Stop the engine on the machine and remove the ignition key.



CAUTION: Damage to the environment.

Risk of damage to the environment if you incorrectly discard waste materials.

Obey the local regulations when you dispose of waste material.

Procedure

1. Open the left front shield.
2. Install the support to hold the shield in position.

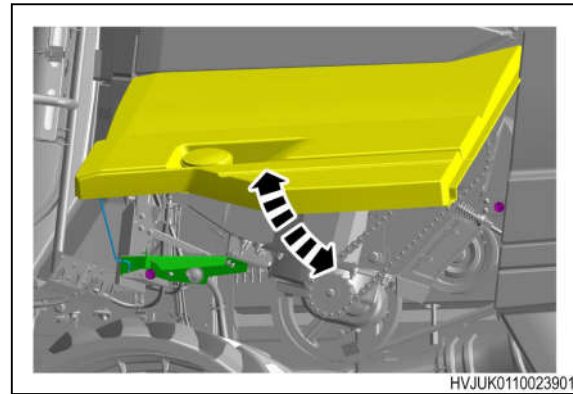

Fig. 701

3. Clean the area around the fill plug (1), the drain plug (3), and the sight glass(2).

4. NOTE:

Put a container in an applicable position to collect all fluids that come out during the procedure.

Remove the drain plug (3) and drain the oil.

5. Examine the seal on the drain plug. Replace if necessary.
6. Install the drain plug (3) and tighten to a torque of 70 Nm.

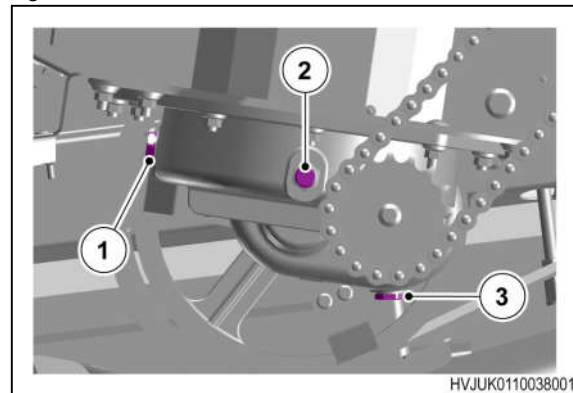

Fig. 702

7. **IMPORTANT:** Do not fill the gearbox with too much oil.

Remove the fill plug (1). Add oil through the fill plug hole until the oil level aligns with the center of the sight glass(2).

8. Install the fill plug. Tighten to a torque of 70 Nm.
9. Close the left front shield.
10. Do a check of the operation of the machine.

Related Links

Unusual noises from the hydrostatic system.

Cause	Solution
Air in the hydrostatic system.	Examine the reservoir oil level. Fill the reservoir with hydraulic oil if it is necessary.
Hose or pipe not installed correctly and touches other components on the machine.	Examine the hoses and pipes to make sure that they do not touch other components on the machine. Move the hose or pipe, if it is necessary.

The increase and decrease of the machine's speed is slow.

Cause	Solution
Air in the hydrostatic system.	Examine the reservoir oil level. Fill the reservoir with hydraulic oil if it is necessary.
The hydraulic oil pressure is low.	Replace the hydraulic oil filter. Speak with your dealer.
Hydraulic oil filter blockage, this prevents the flow to the hydrostatic pump.	Replace the hydraulic oil filter.
Internal problem in the hydrostatic system.	Speak with your dealer.

ParaLevel - front tires

Tire dimensions	Load index	Tire load capacity at 15 km/h	Tire load capacity at 40 km/h	Index radius	Rim dimensions	Offset	Maximum width
800/70 R32	185A8	14340 kg	9250 kg	925 mm	DW27Bx32	195 mm	3490 mm
800/70 R38	184A8	13950 kg	9000 kg	975 mm	DW30Bx32	198 mm	3490 mm
900/60 R38	184A8	13950 kg	9000 kg	975 mm	DW30Bx32	50 mm	3680 mm

Permitted wheel and tire assemblies

Front	Rear		
	520/80 R26	620/70 R26	750/65 R26
800/70 R32	x	x	
800/70 R38	x	x	
900/60 R38	x	x	x

NOTE: X = the only permitted assembly

Machine width

Dimension	Index radius	Maximum width
26 in	600 mm	3290 mm
30 in	600 mm	3490 mm
36 in	600 mm	3790 mm

Track - permitted track and tire assemblies

Front	Rear		
	520/80 R26	620/70 R26	750/65 R26
26	x		
30	x	x	
36	x	x	x

NOTE: X = the only permitted assembly

Rear tires

Tire dimensions	Load index	Tire load capacity at 15 km/h	Tire load capacity at 40 km/h	Index radius	Rim dimensions	Offset	Maximum width
520/80 R26	168A8	7450 kg	5600 kg	700 mm	DW16Ax26	- 5 mm	3290 mm
620/70 R26	173A8	8650 kg	6500 kg	725 mm	DW20Bx26	- 5 mm	3490 mm
750/65 R26	166A8	8215 kg	5300 kg	750 mm	DW25Bx26	- 5 mm	3680 mm(144.9 in) ^[1]

[1] For track machines: 3790 mm

Grain handling	IDEAL 7	IDEAL 8	IDEAL 9
Clean grain elevator - doors with openings	#	#	#
Clean grain elevator low speed - (258 RPM)	X	X	#
Clean grain elevator high speed - (430 RPM)	-	-	X
Streamer 140: • Grain tank 12500 l • Unloader rate 210	X	X	# (PL only)
Streamer 210 • Grain tank 17100 l • Unloader rate 210	#	#	X
Unloader distance	7.6 m - 9.2 m - 10.6 m	7.6 m - 9.2 m - 10.6 m	7.6 m - 9.2 m - 10.6 m
Foldable unloader auger (9,2 - 10,6m)	#	#	#
Grain tank covers hydraulic foldable	X	X	X
Unloader - spill saver	X	X	X
Unloader gates hydraulic	X	X	X
Grain tank - grass seed kit	#	#	#

Residue management

X = standard , # = optional , - = not available

Residue management	IDEAL 7	IDEAL 8	IDEAL 9
Chaff spreader - manual adjustment.	#	#	#
Chaff spreader - electric adjustment.	#	#	#
BaseCut straw chopper	X	X	X
BaseCut rows / knives	4 / 56	4 / 56	4 / 56
ShortCut straw chopper	#	#	#
ShortCut rows / knives	8 / 112	8 / 112	8 / 112
Chop to drop - manual	X	X	X
Straw chopper dual speed	X	X	X
Straw chopper speed - high / low	3600 / 850 RPM	3600 / 850 RPM	3600 / 850 RPM

Tire	Front axle height position	Rear axle height position	Axle tilt stop
750/65 R26 rear 900/60 R38 front	Center	High	No spacers
750/65 R26 rear 1000/55 R32 front	Center	High	No spacers
750/65 R26 rear 710/70 R42 front	High	High	No spacers
750/65 R26 rear Track front	Not applicable	High	No spacers

6.1.14 Rear wheel assist axle width configuration

Tire dimensions	Rear axle width	Travel distance of the steering cylinder	The number of travel stops for each side of the steering cylinder
520/80 R26	3.3 m	138 mm	2
	3.5 m	126 mm	4
	3.6 m	155 mm	0
520/85 R30	3.3 m	-	-
	3.5 m	126 mm	4
	3.6 m	155 mm	0
620/70 R26	3.5 m	132 mm	3
	3.6 m	144 mm	2
	3.7 m	150 mm	1
710/60 R30	3.7 m	108 mm / 114 mm	6 / 7
	3.8 m	120 mm / 126 mm	4 / 5
	3.9 m	132 mm	3
750/65 R26	3.7 m	108 mm	7
	3.8 m	108 mm	7
	3.9 m	108 mm	7

6.1.15 Steering specifications

Rear axle type

	IDEAL 7	IDEAL 8	IDEAL 9
Standard axle	Adjustable axle width		
Optional axle	Adjustable axle width with Rear Wheel Assist (RWA)		

8.6 Install the fire extinguisher



WARNING: The machine can move without warning.

The machine is heavy and can cause death or injury.

Park the machine on a clean, hard and level area. Set the parking brake to ON and install the wheel chocks.

Make sure that you install a fire extinguisher on the machine. Examine the fire extinguisher regularly. Make sure that it is in good condition and that it will operate if necessary.

NOTE:

Find the support bracket on the platform. Different platform configurations can cause the support bracket location to change.

Procedure

1. The support bracket (1) has 4 holes that line up with the holes on the fire extinguisher bracket (2).
2. Attach the fire extinguisher bracket with the fasteners to the support bracket (1).
3. Install the fire extinguisher with the strap (3).

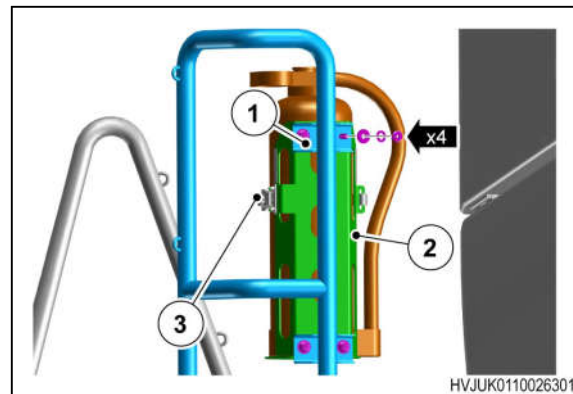

Fig. 2

CLICK HERE TO **DOWNLOAD** THE COMPLETE MANUAL

- Thank you very much for reading the preview of the manual.
- You can download the complete manual from: www.heydownloads.com by clicking the link below



- Please note: If there is no response to CLICKING the link, please download this PDF first and then click on it.

CLICK HERE TO **DOWNLOAD** THE COMPLETE MANUAL