

***5255 L*** from serial no. 555000001

***5255 L MCS*** from serial no. 555000001

***6275 L*** from serial no. 565000001

***6275 L MCS*** from serial no. 565000001

**ORIGINAL  
OPERATOR'S MANUAL**

**FENDT**

CLICK HERE TO **DOWNLOAD** THE COMPLETE MANUAL

- Thank you very much for reading the preview of the manual.
- You can download the complete manual from: [www.heydownloads.com](http://www.heydownloads.com) by clicking the link below



- Please note: If there is no response to CLICKING the link, please download this PDF first and then click on it.

CLICK HERE TO **DOWNLOAD** THE COMPLETE MANUAL

**Chaff spreader identification (if fitted) - Fig. 10**

The type plate is located on the right-hand side next to the chaff spreader adjustment lever.

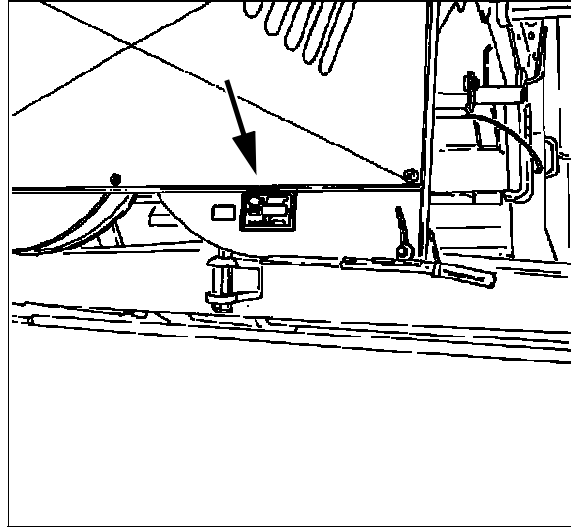

Fig. 10

**Trailer hitch identification (if fitted) - Fig. 11**

The plate is positioned on the right-hand side of the trailer hitch.

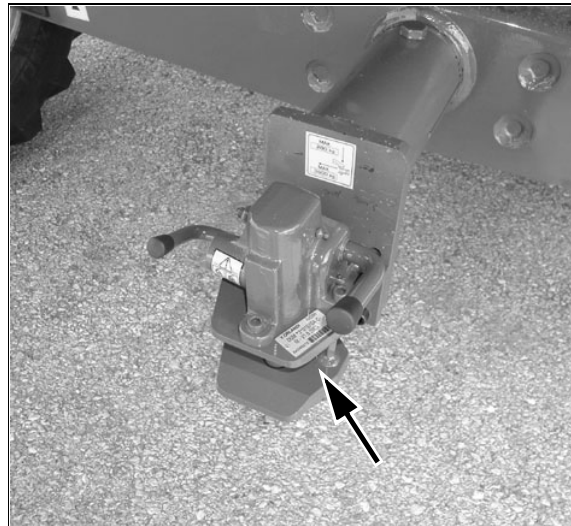
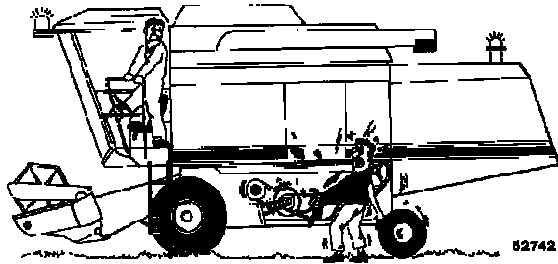

Fig. 11



**DANGER:** Risk of getting trapped.

- 16.) Never work on the machine wearing loose clothing that could get caught in a moving part. Check that all rotating parts are protected with safety guards.



- 17.) Keep clear of all moving parts on the machine and particularly on the table.

- 18.) After any lubrication, adjustment or repair work, always refit all safety guards. Replace or repair missing or damaged safety guards immediately.



**DANGER:** Risk of falling.

- 19.) Do not step onto the grain tank cover or cab roof.

To reach high areas (for example, the inspection lids on the unloading tube), use the access ladder for the engine area.

- 20.) While operating the combine, pay special attention to correct function and the efficiency of the braking system, checking the oil level in the tank and replacing friction pads before they wear out completely.



**DANGER:** Risk of explosion.

- 21.) It is strictly forbidden to modify a hydraulic accumulator by mechanical machining, welding, etc.

For the accumulator inspection or replacement, refer to your local Dealer.

## Engine

- 1.) Never start the engine if battery recharging equipment is connected to the machine.

- 2.) Always keep the engine and the engine compartment clean. Dust, diesel oil, oil and accumulated straw are highly flammable.

For the same reason, also keep the transmission housing and the brake system clean.

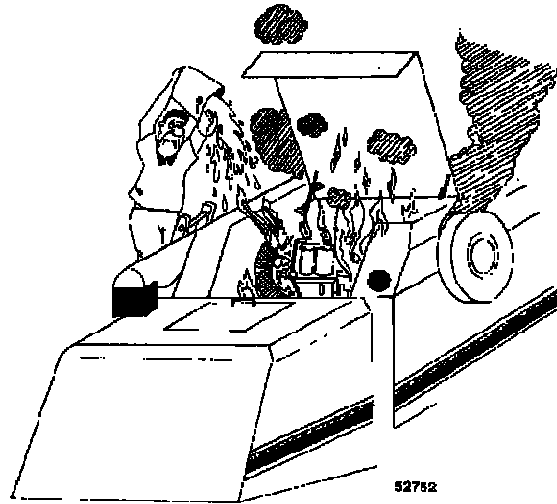

**DANGER:** Risk of breathing in toxic gases.

- 3.) Never operate the engine in an enclosed area without ensuring proper ventilation, since highly toxic exhaust gases are generated.

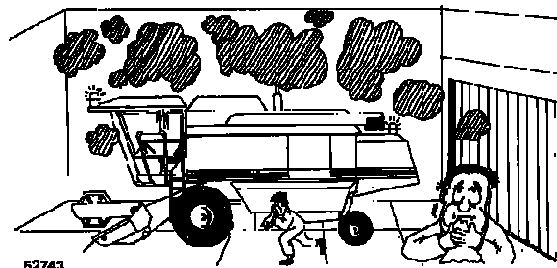

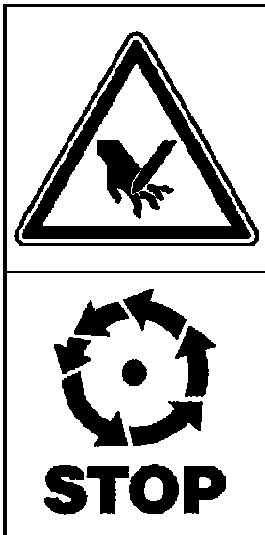

4375813M1  
Decal 13

Before accessing machine parts, wait until all moving parts have come to a complete stop.

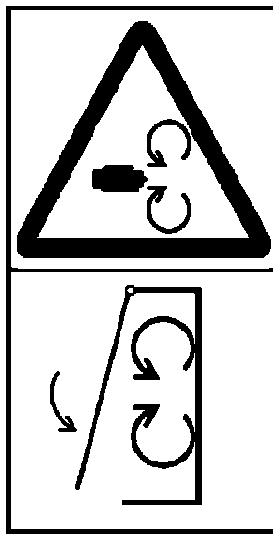

341000007  
Decal 14

Close the safety guards before operating the machine.

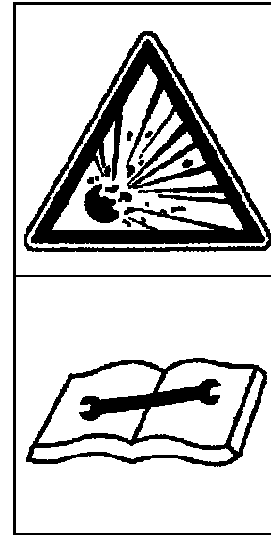

341000014  
Decal 15

Hydraulic accumulators contain pressurised gas and oil. To check or replace hydraulic accumulators, consult your local Dealer.

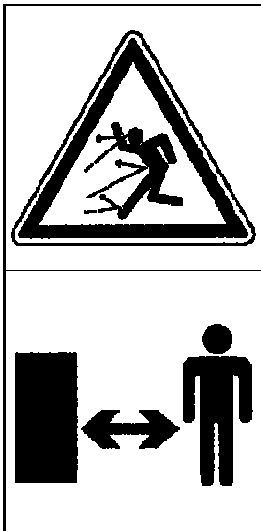

4375849M1  
Decal 16

Danger of flying objects. Keep a safe distance from the machine.

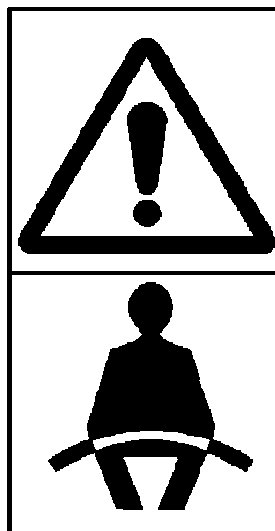

4375987M1  
Decal 17

Fasten driver and passenger safety belts before moving the machine.

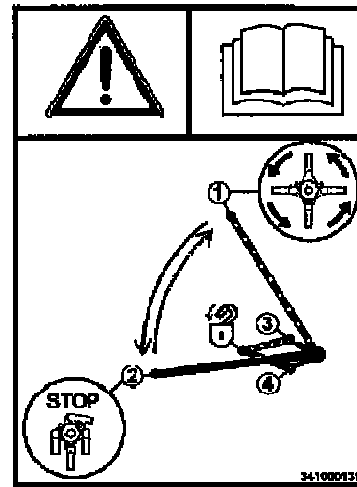

341000131  
Decal 18

For correct use of the positioning lever for straw chopper deflector plate: Follow the instructions on page 10-9.

**Safety Guards**

Fig. 29

For safety reasons and in compliance with European Directives, the safety guards are equipped with a quick lock that can only be opened with a special tool. This is to prevent unauthorised persons from accessing dangerous areas of the machine.

This tool may be a special key (1), a flat-head screwdriver or a fixed 13-mm wrench.

The key (1) for opening the guards is supplied with the ignition key.

It is recommended to remove both of them from the ignition lock when leaving the operator seat.

Another key for opening the guards is located on the left-hand side of the main crop elevator housing.

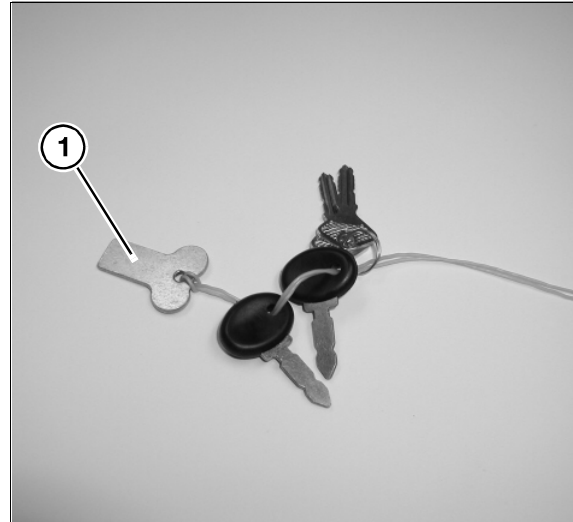

Fig. 29

**Fall protection rails**

Fig. 30 and Fig. 31

To prevent the operator from falling during inspection and maintenance operations, these models are equipped with two folding rails.

The front rail (1) is located on the left-hand side of the engine housing.

The rear rail (2) is fitted on the upper right-hand side of the straw walker housing.

These rails must always be in the raised position when the operator climbs onto the upper part of the machine.

 **DANGER:** Risk of electrocution.

When the rails are raised, the lever (3) automatically engages the pin (4) to hold the rail in the raised position until the operator releases it by pressing the upper part of the lever (3) inward.

**When working and driving on public roads, the rails must be folded onto their dedicated supports.**

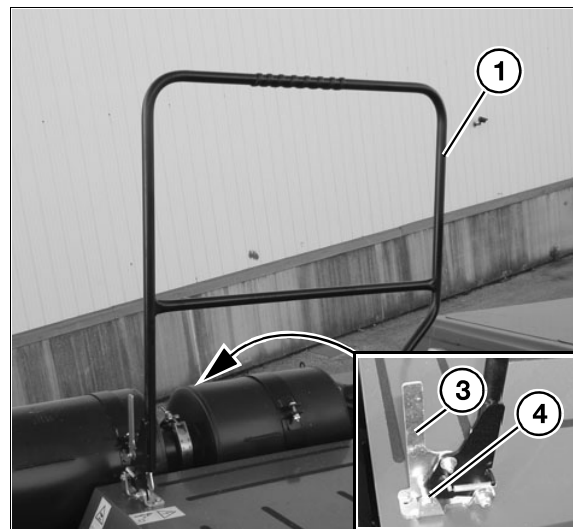

Fig. 30

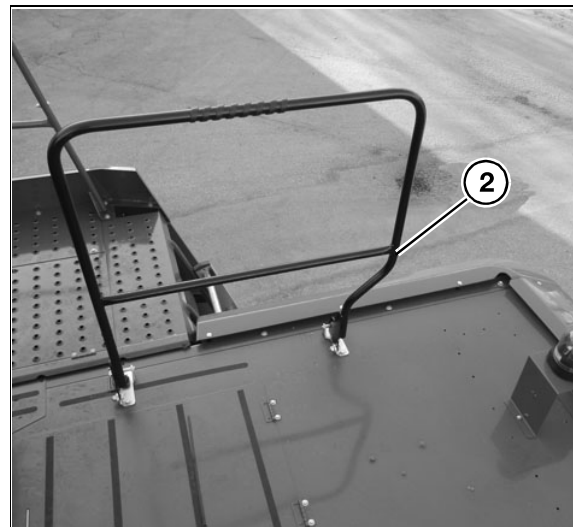

Fig. 31

## 2. OPERATION

### 2.1 OPERATION - CROP PROCESSING

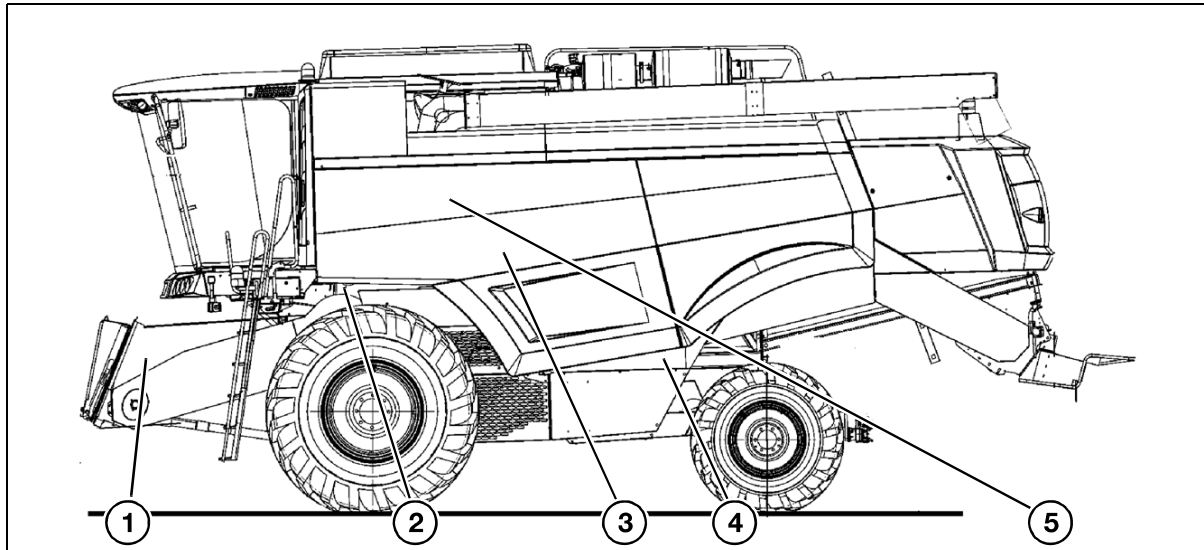
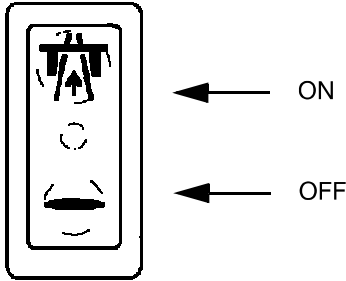

Fig. 1

**The combine performs five basic operations - Fig. 1**

- 1. Feeding**
- 2. Threshing**
- 3. Separation**
- 4. Cleaning**
- 5. Grain storage and unloading**

4.) Switch for “on-road functions”.



7.) Toggle switch for concave rear adjustment.

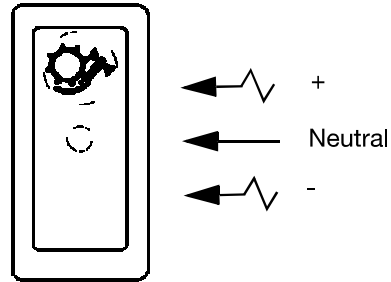

5.) Switch for light in grain tank.

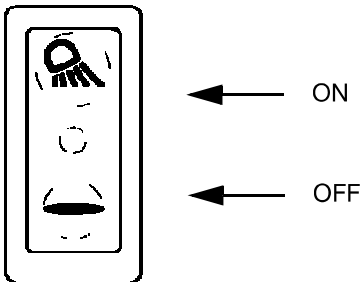

8.) Catalytic converter fluid (DEF) minimum level indicator.

- It comes on for 10 seconds on ignition when the fluid in the tank is between 15 and 10%.
- Between 10 and 5% it comes on and stays on.
- From 5% onwards it flashes.
- At 0% the indicator (9 in flashing mode) comes on and the buzzer sounds.

6.) Toggle switch for concave front adjustment.

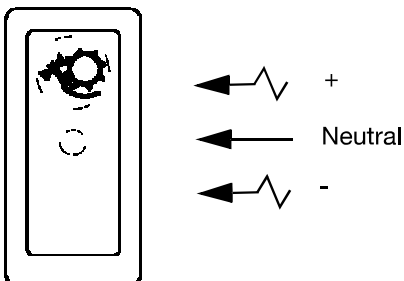

9.) Fume reduction system fault indicator (SCR).

10.) Switch for hazard light.

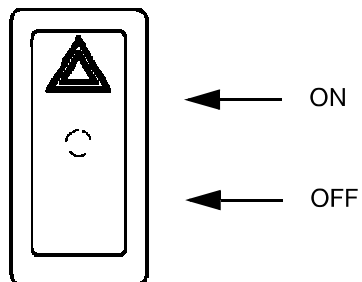

**PARTIAL HECTARE COUNTER**

Fig. 22

The hectare counting can be varied by 1/4, 1/2 or 3/4 if the full table width is not used.

**How to Change the Counting**

If the full table width is not used, the counting can be reduced by pressing the key (19).

With each touch of the key the system beeps and the table width is reduced by 1/4 compared to the width set in the computer.

When the key is pressed three times, the hectare counting is reduced to 1/4.

To return to total counting, just lift the cutting table.

Alternatively, return to total counting by pressing the key (19) for more than three seconds.

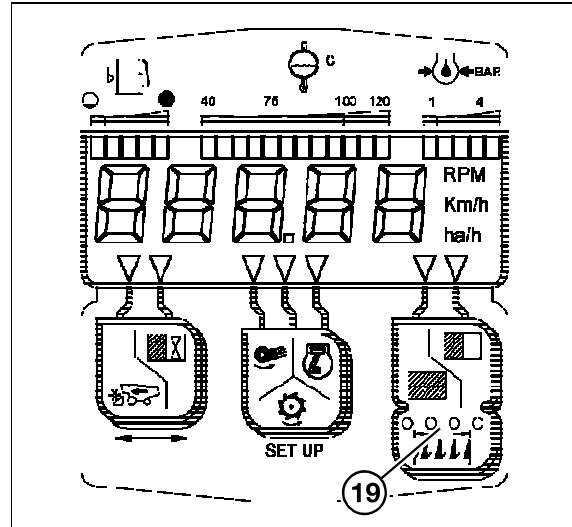

Fig. 22

**HECTARE COUNTER OPERATION**

Fig. 23

Check that the value set in the computer, C6, corresponds to the table cutting width.

The instrument starts operating when the following conditions are present:

- The cutting table is working.
- The angular position sensors measure that the height of the cutting table above the ground is less than 19 cm (sensors on cutting table) or less than 50 cm (sensor on the main crop elevator).

**NOTE:** The angular position sensors are always active, even when the ECU is in manual mode.

- The machine is moving forwards (signal coming from the sensor in the gearbox).

Under these conditions the hectare counter considers the total width of the cutting table.

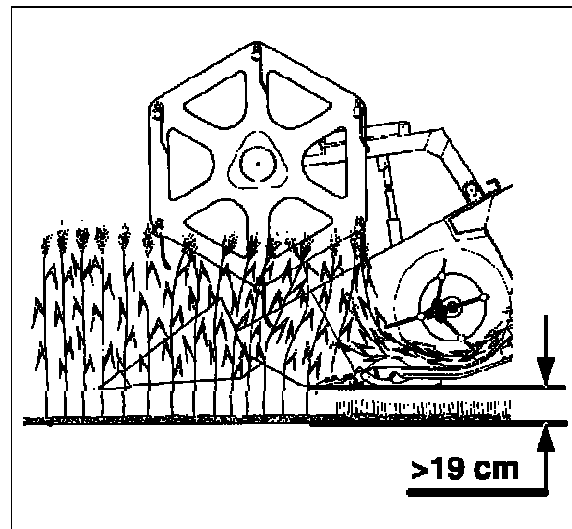

Fig. 23

**ADJUSTING THE ANGULAR POSITION SENSOR FOR TABLE FLOATATION**

Fig. 47 – Fig. 52



**DANGER:** *Of squeezing, cutting or shocks.  
Never climb under the cutting table unless the safety stops in the lifting rams have been engaged.*

The adjustment of skids and angular position sensors is very important for the operation of:

- **Terra Control** system (cutting height control system).
- **GSAX** system (cutting table transversal position).
- **Hectare counter**.

Proceed as follows:

- a.) Attach the cutting table to the combine and connect the electric cables.
- b.) **Place the cutting table on the ground** (skids (1) fully closed).
- c.) Select **floatation** mode using the push button (2).

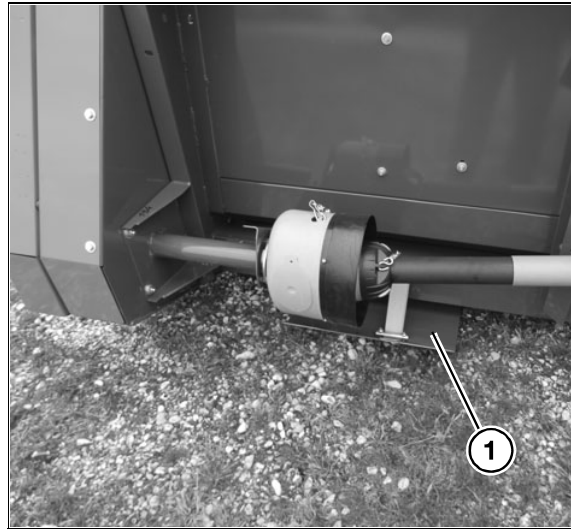

Fig. 47

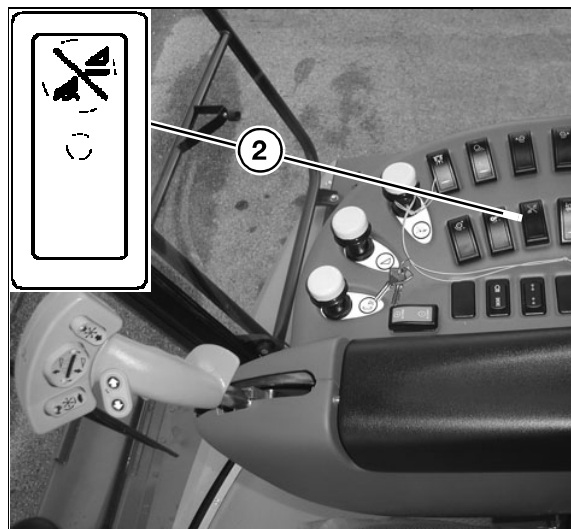

Fig. 48

- d.) Press the keys (3 and 4) for three seconds at the same time.
- e.) **A 10** will be displayed.

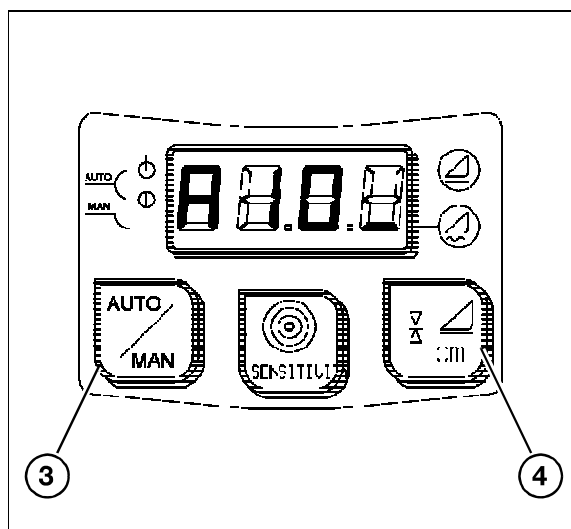

Fig. 49

### FOOTREST

Fig. 74

There is a footrest on the left-hand side of the cab floor. This is particularly useful when the machine is being operated downhill.

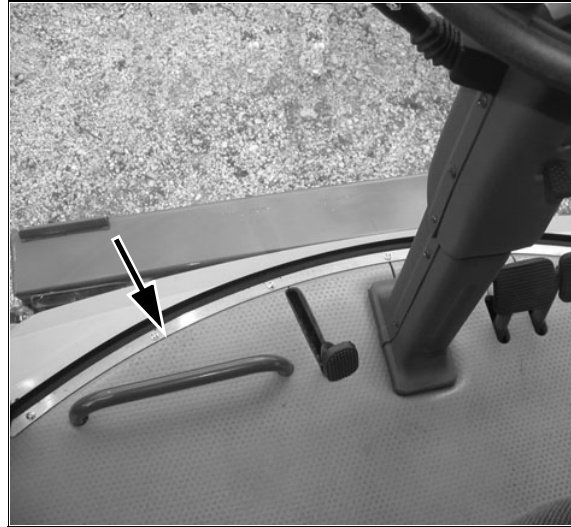

Fig. 74

### PREPARATION FOR RADIO INSTALLATION

Fig. 75 and Fig. 76

The cab is prepared for fitting a radio.

The components are located in the following areas:

- Aerial and radio connectors are located behind the panel (1) for light switches.
- The loudspeakers (2), fitted as standard, are on the rear of the cab roof.
- The housing (3) where a radio can be fitted is above the light switches.



Fig. 75

### READING LIGHT

Fig. 76

A reading light (4) is located on the right-hand side of the cab ceiling.

To switch it on, press the rear part of the transparent cover upward; to switch it off, press the front part of the transparent cover upward.

*The reading light can be switched on without the key in the ignition; thus, it is advisable to disconnect the battery when leaving the machine unattended for long periods of time (e.g. overnight stops).*

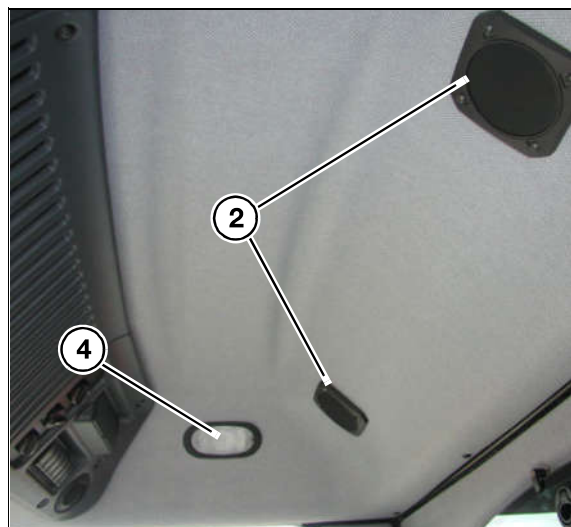

Fig. 76

# 4. FIELD OPERATIONS

## 4.1 GENERAL INFORMATION



**WARNING:** *Certain machine parts (e.g. the reel or knife) cannot be fitted with safety guards for operating reasons. Before starting the engine, check the following:*

- *All persons must keep clear of the combine working range.*
- *Check cutting table and grain tank for loose parts.*
- *Check that the multifunction lever is in the neutral position.*
- *If a straw chopper is fitted, ensure that the spreader hood is in the working position.*
- *Always sound the horn three times to warn persons nearby of your intention to start the engine.*
- *Pay special attention while engaging cutting table and straw chopper and during reel and table lift/lowering.*



**DANGER:** *In case of blocking of any moving part, never push the crop into the cutting table or main crop elevator using hand or foot. This may cause severe injury or death. This may be done only after switching off the engine, waiting until all moving parts have come to a complete stop and removing the ignition key from the switch.*

### Before Operating the Machine in the Field

- 1.) Read this Operator's Manual thoroughly, particularly the sections "General Information" and "Starting the Engine".
- 2.) Check the wheel nut tightening torque.

- 3.) Check the tyre pressure (observing the pressures specified in the tables on page 11-2).
- 4.) Check the oil levels in the engine and hydraulic and hydrostatic systems with fully retracted hydraulic rams and cutting table lowered to the ground, as well as the engine coolant level (ensure the machine is on level ground). Refer to the section "Lubrication and maintenance".
- 5.) Check the tension of all chains and belts. Refer to the section "Adjustments".
- 6.) Thoroughly lubricate the machine as described in the section "Lubrication and maintenance".
- 7.) Adjust the operator seat according to the operator's weight and size.
- 8.) Adjust the steering wheel to the desired position.
- 9.) If required, adjust the rear view mirrors.
- 10.) Adjust the cutting table (see specific Operator's Manual) and threshing unit to the type of crop to be harvested, see table on page 4-37.
- 11.) Make sure the battery switch is in the **ON** position (see page 3-41).
- 12.) Turn the ignition key to position 1 and check that all indicator lights and buzzers are operating correctly.

**IMPORTANT:** *Be sure to check the operation of the straw walker and straw chopper jammed indicators (if fitted). The horn should sound when the moving part is pushed against the fixed part.*

- 13.) Start the engine and allow it to run at idling speed for 5 minutes.
- 14.) Engage the threshing unit.

**IMPORTANT:** *To ensure correct operation of the threshing unit drive belt, always engage it when the engine is running at idle speed.*

- 15.) Increase the engine speed to maximum.

**REVERSING**

Fig. 27 – Fig. 29

The machine is supplied with a special system for reversing the rotational direction of the cutting table (1) and main crop elevator (2).

In case of a blockage of table auger or main crop elevator activating the safety clutch, proceed as follows:

- 1.) Immediately stop the combine and disengage the cutting table by pressing down the control switch.
- 2.) Move the machine a few metres back and **reduce the engine speed to idling**.
- 3.) Pull the lever (3) for the reversing mechanism (4) upwards until all the material has been ejected.
- 4.) Release the lever (3).
- 5.) Lift the reel and engage the table drive.
- 6.) The crop can be slowly fed by the reel into the table auger.

 **CAUTION:** *If the blockage cannot be removed by the reversing mechanism, disengage the threshing unit, switch off the engine and wait until all moving parts have come to a complete stop before removing the blockage manually.*

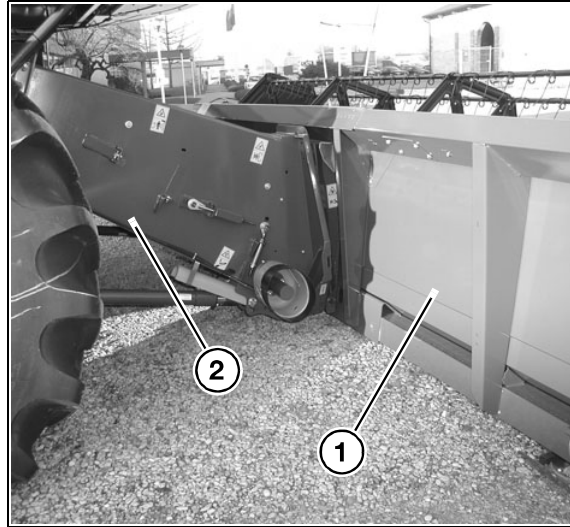

Fig. 27

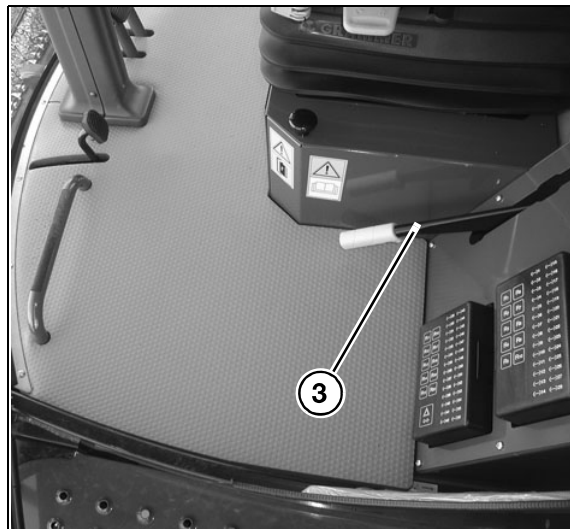

Fig. 28

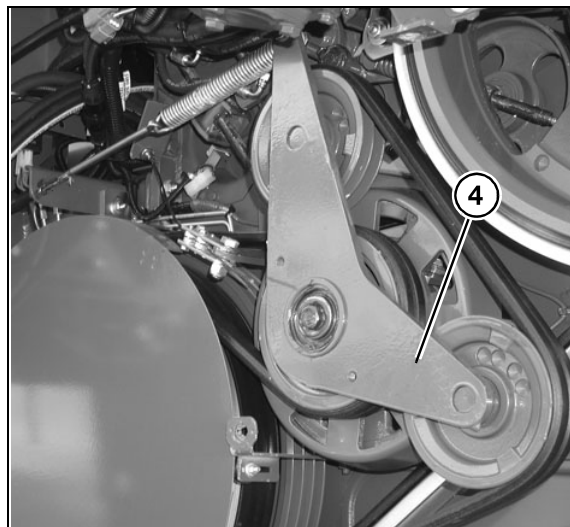

Fig. 29

**Disengaging the Multi Crop Separator concaves**

Fig. 56 – Fig. 58

Proceed as follows:

- 1.) Stop the engine and turn the ignition key to position 1.
- 2.) Release the concave by pulling out the two locking catches (1) on both sides of the combine.

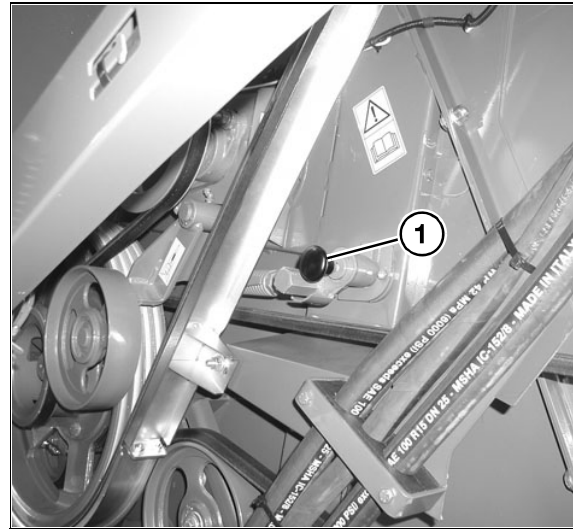

Fig. 56

- 3.) Operate the switch (2) that starts the motor (3) until the pointer (a white arrow) reaches the appropriate reference position (see decal on the previous page).
- 4.) To restore the concaves in their original position, proceed in reverse order, ensuring that the locking catches (1) are refitted properly.

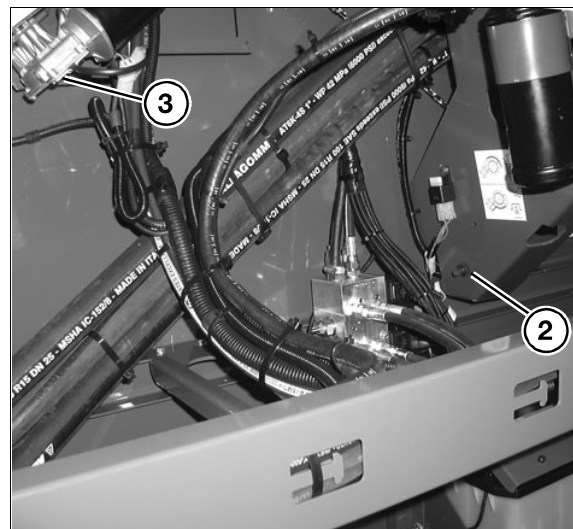

Fig. 57

**IMPORTANT:** Before re-engaging the rotary separator concaves in the work position, check that the ABC module (4) is in the correct position.

Proceed as follows:

- a.) Open a concave side inspection door.
- b.) Check that the bolt (5) is in the central hole.  
**NOTE:** If the bolt (5) is not in the central hole, the ABC module must be repositioned (see page 4-19).
- c.) Having completed the operation, refit the relevant side door.



Fig. 58

## 4.15 RETURNS

Fig. 87 – Fig. 89

Any crop not completely threshed (heads, etc.) that cannot pass through the bottom sieve openings, is recovered and transported to the cylinder for rethreshing. To optimise combine performance the returns volume should be reduced to a minimum.

### Adjustments to Reduce the Returns Volume

In case of excessive returns volume the following action should be taken

- Check the parallelism of concave wires and replace them, if required.
- Adjust the opening of the top and bottom sieves trying to find the right compromise between more open sieves and higher fanning mill speed.
- Check that the fanning mill deflector is positioned at half stroke to distribute the air blast evenly on the sieves.
- Make sure that the fanning mill speed provides optimum separation of chaff and grain.

### Cleaning the Returns Auger



**WARNING:** Always stop the engine, remove the ignition key, apply the parking brake and wait until the machine has come to a complete stop before starting any cleaning or adjustment.

Proceed as follows:

- Remove the lever (1) on both sides.
- Open the lid (2) and clean both the auger (3) and the auger housing using a scraper.
- Open the lid (4) and repeat the cleaning in the auger housing (5).
- Having finished the cleaning, close the lids (2 and 4).

**NOTE:** In the same way the grain auger (6) conveying the crop to the grain tank through the elevator, can be cleaned.

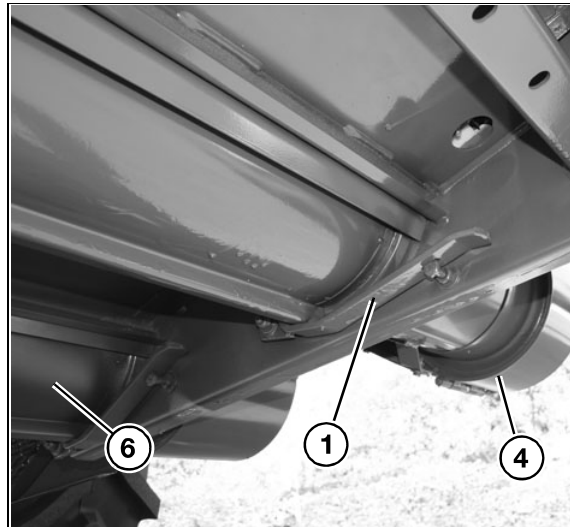

Fig. 87

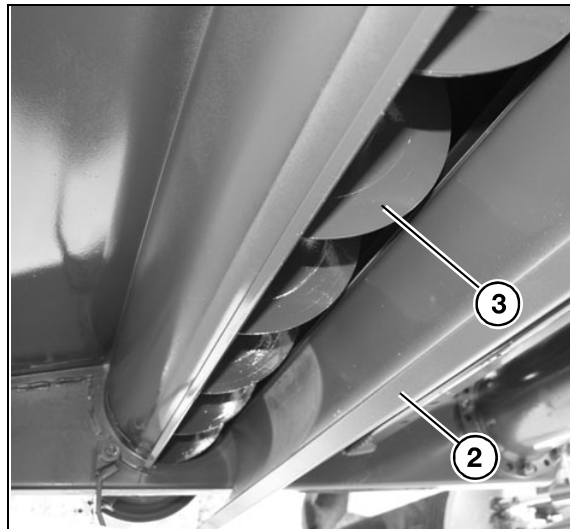

Fig. 88

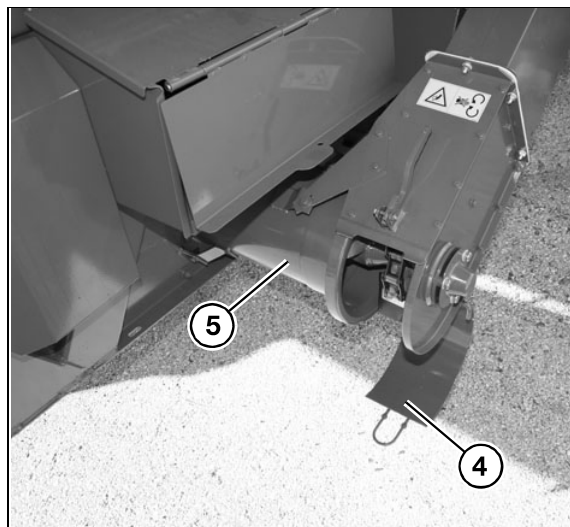

Fig. 89

CLICK HERE TO **DOWNLOAD** THE COMPLETE MANUAL

- Thank you very much for reading the preview of the manual.
- You can download the complete manual from: [www.heydownloads.com](http://www.heydownloads.com) by clicking the link below



- Please note: If there is no response to CLICKING the link, please download this PDF first and then click on it.

CLICK HERE TO **DOWNLOAD** THE COMPLETE MANUAL

### 5.3 SCHEDULED SERVICE INSPECTION

**OPERATION - Fig. 3**

The system warns the operator when the scheduled service inspections are to be carried out.

The service inspection intervals are stored in the computer.

During the functional test and machine data reading at startup, if one of these intervals has been reached, the display will show (along with a flashing "S" on the left) alternately the hours until the scheduled service inspection is due and a letter identifying the type of inspection to be carried out (a, b or c, please see table below).

This alternating display continues for 5 minutes if the service inspection has not yet been carried out.

The display can be cancelled by pressing any key.

Service inspection intervals:

Due (hours)	For service after (hours)	Type
65	75	a
130	150	b + a
215	225 (*)	a + Sisu engine
280	300	b + a
365	375	a
420	450 (*)	c + b + a

**(\*) Additional maintenance required at the Dealer's workshop (page 5-36).**

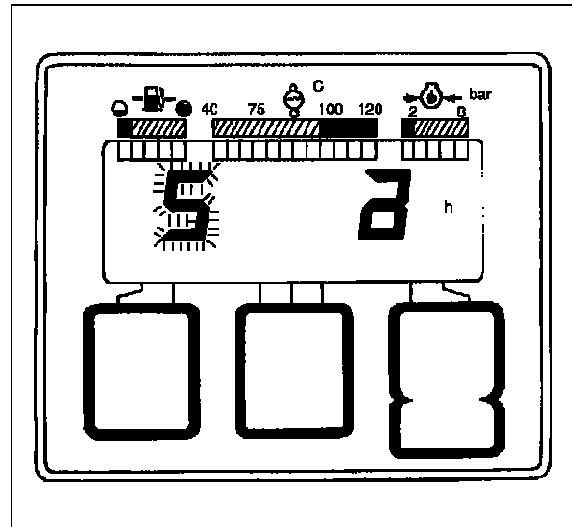

Fig. 3

**Recording Performed Service Inspection -**

Fig. 4

- Using the key (1) select the forward speed; the left arrow (2) is on.
- Press the key (1) again; after 3 seconds the arrow (2) above the key starts to flash and after a further 5 seconds a beep indicates that recording is complete.

**NOTE:** If the service inspection cycle must be reset before 450 hours, simultaneously press the right (3) and left (1) keys for six seconds.

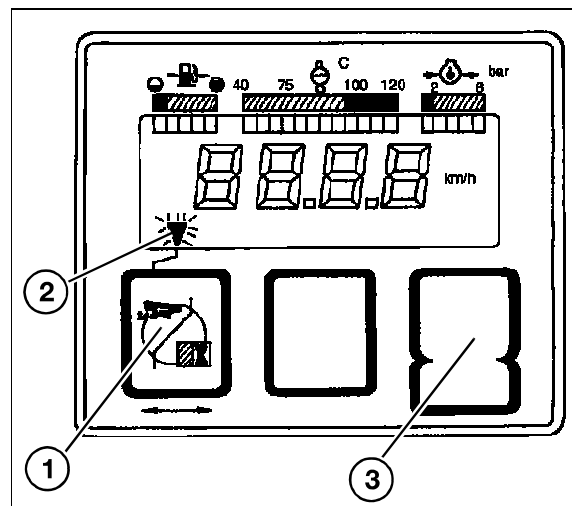

Fig. 4

## 21.) CAB AIR FILTERS

Fig. 27 and Fig. 28

The cab is equipped with two air filters, the outer filter cleaning the air taken in by the system and the inner filter absorbing impurities that may enter the cab while the door is open.

Under particularly dusty working conditions, maintenance should be carried out at shorter intervals (every 10 working hours).

**WARNING:** Always wear eye protection and a dust mask when carrying out maintenance work on the cab filter.

To remove the filters, proceed as follows

- Inner cab filter: Loosen the two screws (1) and remove the grid (2). Remove the screw on the left-hand side and pull out the filter.
- Outer cab filter: Loosen the knob (3) and remove the guard (4). Remove the two blocks holding the filter and pull out the filter.

To clean the filters, proceed as follows:

- Lightly tap the filters against a hard, flat surface, the outer side (the one with the protection mesh) facing downward. Clean the filter pleats using compressed air (pressure below 7 bar) from the inside out.

Refit the filters in their seats.

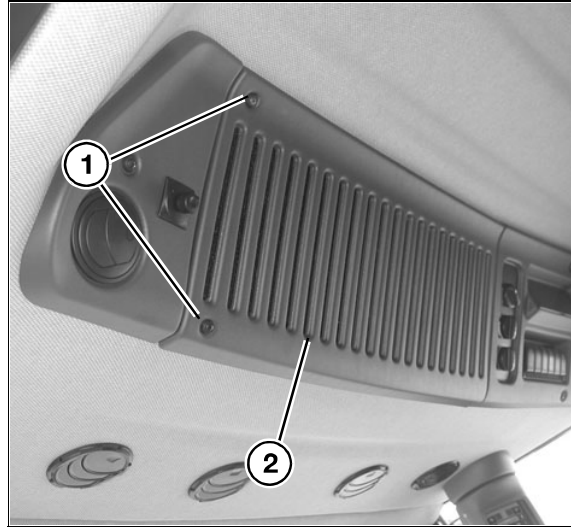

Fig. 27

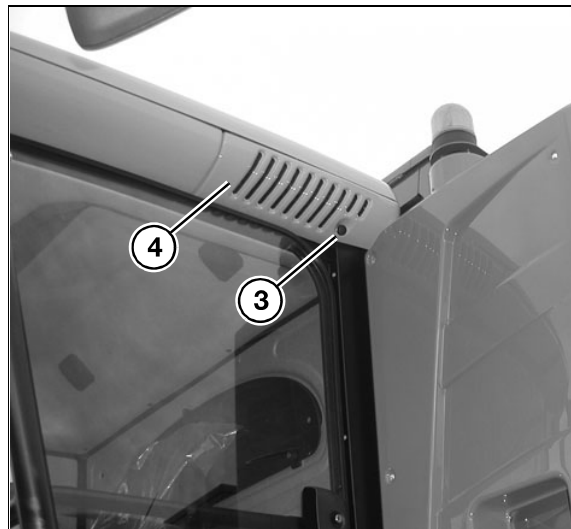

Fig. 28

## 22.) EVAPORATOR

Fig. 29

Open the cab doors completely.

Remove the inner filter and clean the evaporator with a jet of air (when doing this, operate the fans for easier ejection of dust from the compartment under the roof). Check that condensate is drained properly.

**WARNING:** Always wear eye protection and a dust mask when cleaning the evaporator.

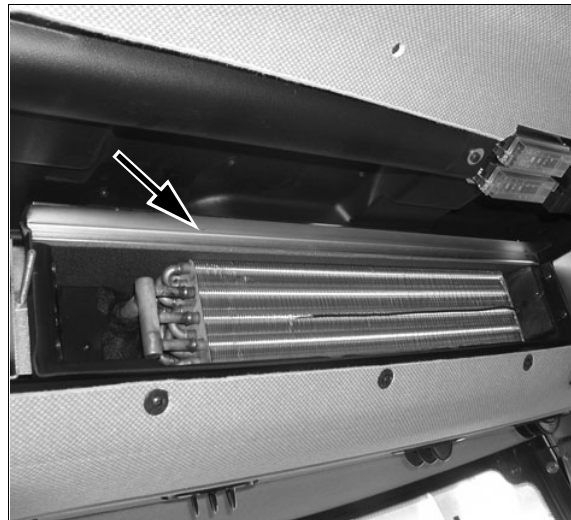

Fig. 29

## SCHEDULED MAINTENANCE WORK

Sa + engine every 225 hours of operation

### 51.) ENGINE OIL AND FILTER

Fig. 54 – Fig. 59



**WARNING:** For safety reasons, never carry out these operations when the oil is hot.

In any case, protect your hands with rubber gloves.

**IMPORTANT:** Change the filter whenever the oil is changed.

If fuel with a sulphur content higher than 0.015 g/kg is used, the intervals for changing the oil and filter must be halved.

To carry out this operation (with warm oil), proceed as follows:

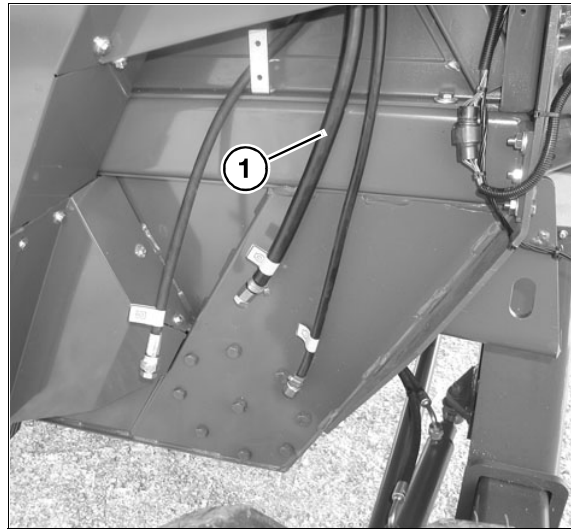

Fig. 54

- a) Remove the plug (1) from the engine oil

drain hose marked with the decal



**WARNING:** Do not dispose of oil in the environment, rather collect it in a suitable container.

- b) Enter the grain tank using the ladder (2) provided and remove the lid (3) to access the engine and the filter (4).

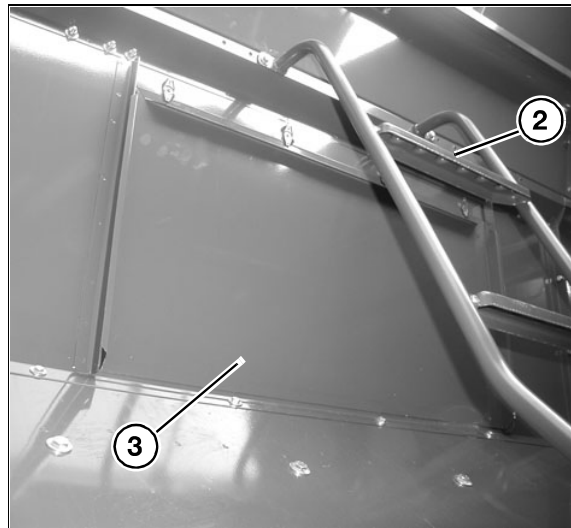

Fig. 55

- c) Carefully clean the area around the filter, loosen it and check that the whole seal is on the filter; remove any seal traces that may still stick to the support.  
 d) Oil the seal of the new filter and tighten it firmly by hand, without using any tools.  
 e) Refit the plug (1) on the engine oil drain hose.

**IMPORTANT:** Only use genuine filters. Dispose of the used filter correctly (for example, by sending it to a centre specialising in the storage and disposal of oil waste).

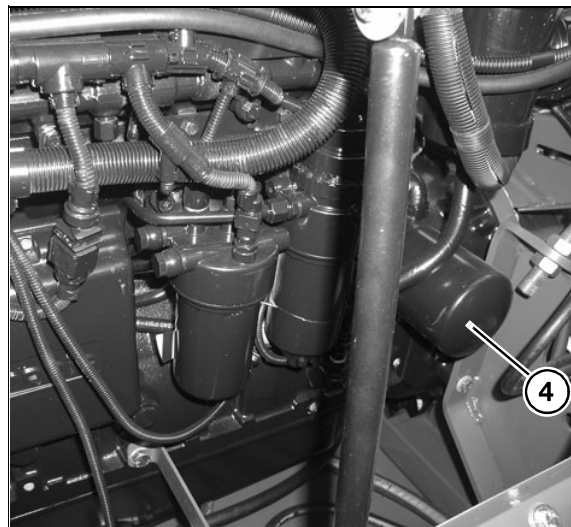

Fig. 56

## 2.) COOLANT

Fig. 80 and Fig. 81

Do not keep coolant in the radiator for more than 1800 hours.



**CAUTION:** Wear suitable gloves to avoid contact with coolant.

Coolant must be changed when the engine is cold.

Proceed as follows:

- 1.) Open the cap (1) on the expansion tank cover.
- 2.) Remove the plug (2) from the drain pipe on the left-hand side of the straw walkers.
- 3.) Collect the coolant in a pan.

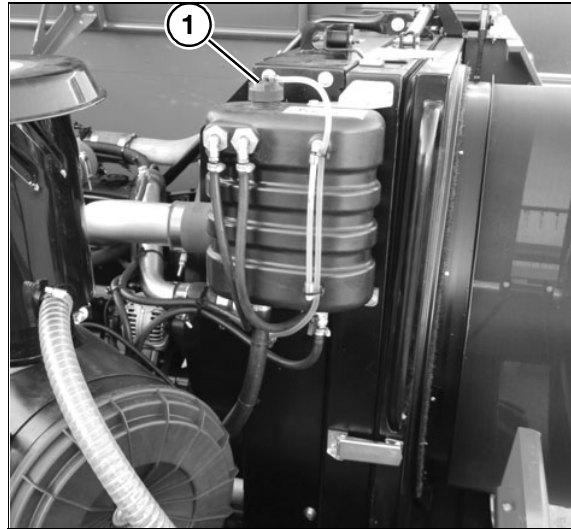

Fig. 80

- 4.) Re-insert the plug (2).
- 5.) Fill the cooling system with clean water to purge it.
- 6.) Start the engine and let it run until it reaches normal operating temperature.
- 7.) Switch off the engine, wait until it has cooled down and open the cap (2) until all the liquid has drained off.
- 8.) Close the plug (2) and fill the system with **ANTI FREEZE** (50% water).  
For coolant capacities, see the table on page 5-35.

**IMPORTANT:** Never use only water as coolant! The recommended blend ensures that the anti-corrosive is always active in the engine cooling system.

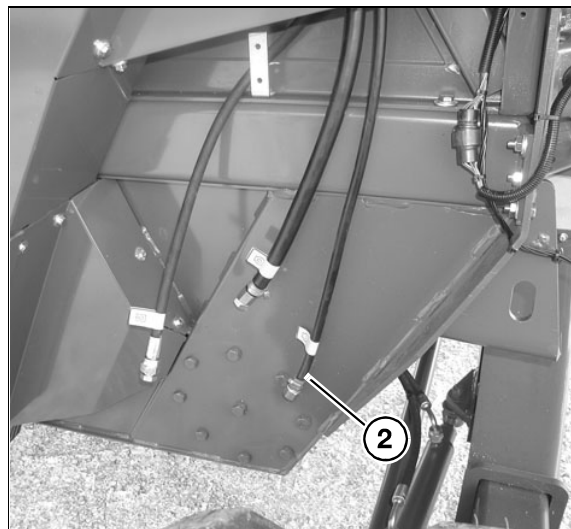

Fig. 81

## 3.) INJECTORS

Fig. 82

To ensure trouble-free engine operation the injectors must be kept in perfect condition.

Have the injectors checked by skilled staff every 1800 hours of operation.



**DANGER:** Do not open the fuel system hoses when the engine is running.

Wait for at least 30 seconds after the engine has stopped.

Fuel under high pressure spraying out may penetrate your skin causing severe injury.

Contact a doctor immediately!



Fig. 82

# 6. ADJUSTMENTS

## 6.1 BELT AND CHAIN ADJUSTMENT



**CAUTION:** Always switch off the engine and remove the ignition key before checking and/or adjusting any belt, chain or other part described in this section.

**ATTENTION:** Before engaging threshing unit, straw chopper, feeding system and tank unloading belts, the engine should be running at idle speed.

**IMPORTANT:** A daily check of all belts and chains ensures optimum machine operation.

**NOTE:** Most tensioners are spring-loaded and supplied with an indicator for correct belt tension.

### 6.3 BELTS AND CHAINS (right-hand side)

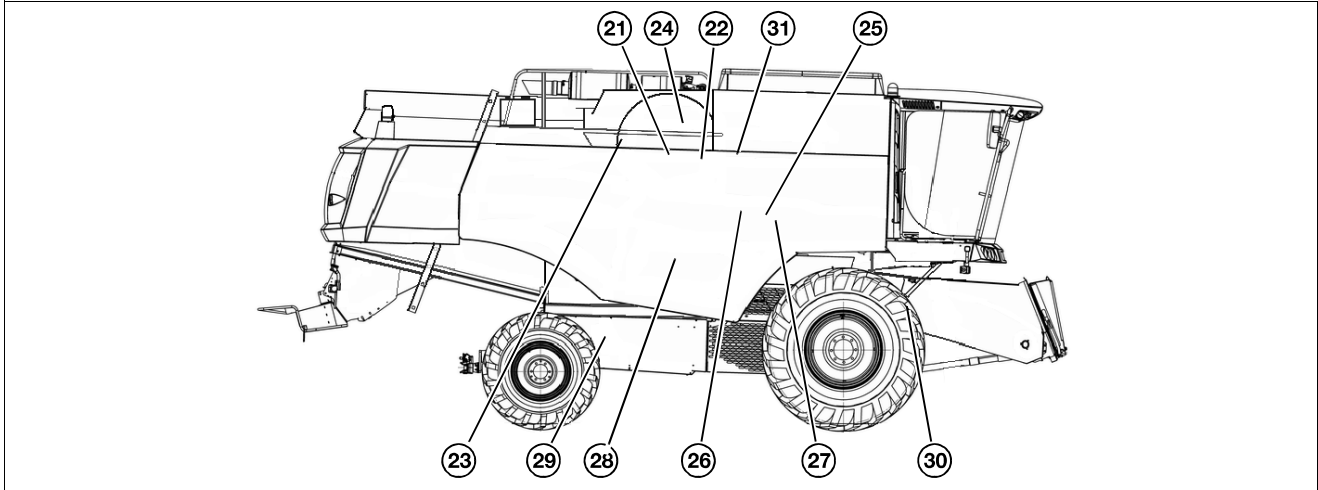

Fig. 22

- |  |   |
|--|---|
| 21.) Belt drive for rotary screen              | 27.) Top chain drive for returns auger  |
| 22.) Counter drive for rotary screen           | 28.) Chain drive for crop elevator      |
| 23.) Belt drive for alternator and cooling fan | 29.) Chain drive for returns elevator   |
| 24.) Belt drive for engine coolant pump        | 30.) Chain drive for main crop elevator |
| 25.) Belt drive for cylinder variator          | 31.) Chain drive for tank filling auger |
| 26.) Belt drive for fanning mill variator      |   |

## 6.6 TYRES

### Tyre pressure

Fig. 43 and Fig. 44

To ensure optimum reliability of the tyres, the instructions below must be observed.

Apply the prescribed pressure both in traction wheels (1) and rear wheels (2). Please refer to the table on page 11-2.

The pressure should not be lower than prescribed, as this may result in:

- Tyre damage
- Bead wear
- Inner damage
- Irregular wear and short life.

Do not inflate the tyres excessively to avoid increasing the sensitivity to damage by bumps. Under extreme conditions, the rim may be deformed or the tyre may burst.

Check tyre pressure at least every 150 operating hours. Before checking, ensure that the tyres are cold.

The tyres can be considered cold when they are left for at least an hour or if they have not run more than two kilometres. When the tyre is used, the pressure increases due to heating.

Never reduce the pressure when the tyres are hot.

When checking the tyres, keep clear of the valves.

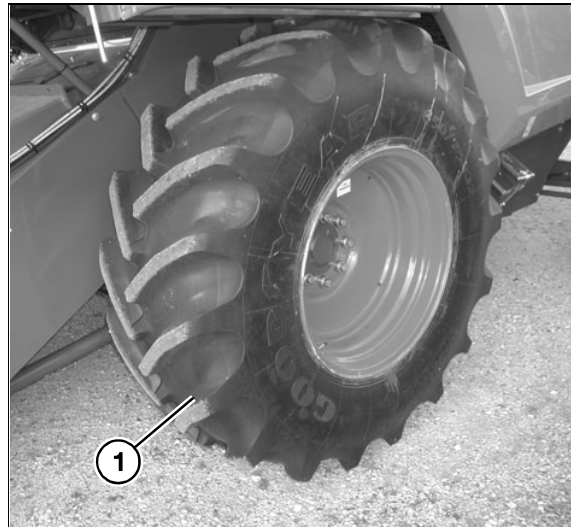

Fig. 43



Fig. 44

## 7. SYSTEMS



**CAUTION:** Always switch off the engine and remove the ignition key before checking and/or adjusting any of the components described in this section.



**WARNING:** Wear protective clothing (overalls, gloves, shoes, goggles, mask, etc.) suited to the operation that you intend to carry out.

**IMPORTANT:** Do not under any circumstances modify the pressure relief valve setting in the hydraulic circuits.  
In case of failure, do not adjust the control valve, but contact your Dealer.

**IMPORTANT:** When a fuse is replaced, ensure that the new one has the same rating as the old one. This is marked on the component.

## TABLE POSITIONING HYDRAULIC CIRCUITS

### Table up/down and reel up/down and longitudinal positioning circuit

Fig. 24 and Fig. 25

Solenoid valve position:

- 1.) Table lift
- 2.) Table lowering
- 3.) Main valve/by-pass valve
- 4.) Reel lowering
- 5.) Reel lift
- 6.) Reel adjustment fore/aft

### Adjustment of table lowering speed

Fig. 25

When changing to a different type of table (e.g. maize header), it may be necessary to adjust the lowering speed.

Proceed as follows:

- Loosen the lock nut (7).

**IMPORTANT:** This adjustment must be carried out when the oil has reached operating temperature. Adjust the screw (8) only by one sixth of a turn at a time. Repeat the adjustment, if required.

- Turn the screw (8) clockwise to reduce the table lowering speed. Turning the screw (8) anticlockwise will increase the table lowering speed.

Tighten the lock nut (7).

### Cutting table oleopneumatic shock absorbers

Fig. 26

There are often pressure spikes in the table up/down positioning circuit (e.g. when the oil to the tank is cut off during table lowering).

To limit the impact of these pressure variations, the table up/down positioning circuit features three different types of oleopneumatic shock absorbers:

- The first shock absorber (1) is always engaged in the cutting table up/down positioning circuit.
- The second shock absorber (2) is engaged in the table positioning circuit only when the table is operating in manual mode.

The shock absorber (2) is automatically engaged by the solenoid valve (3).

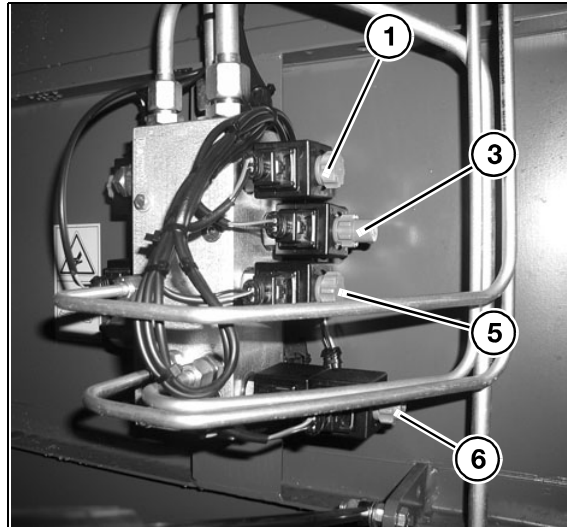

Fig. 24

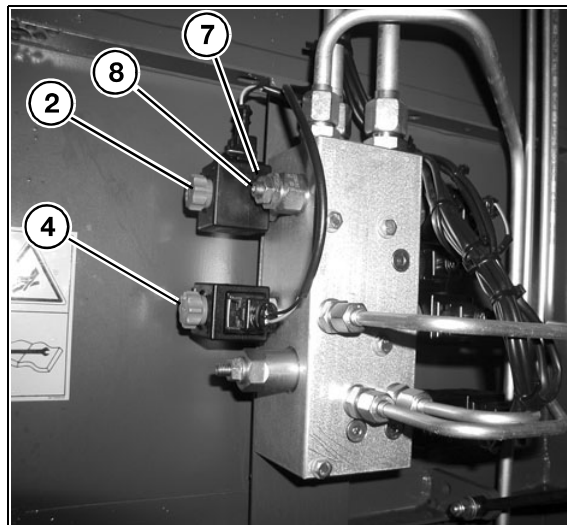

Fig. 25

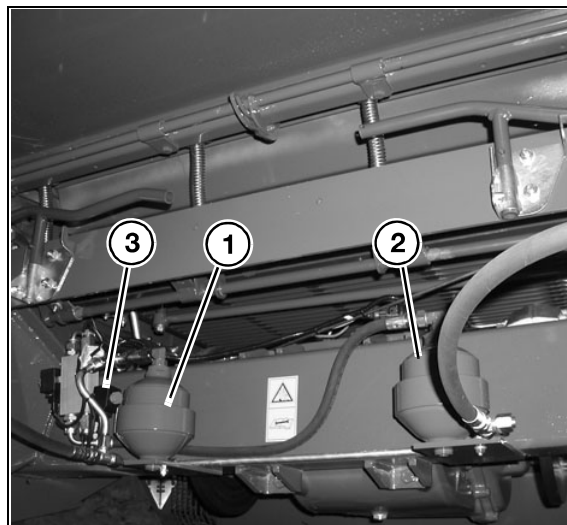

Fig. 26

**ADDITIONAL FUSES**

**Various fuses (engine area)**

Fig. 49

Fuses can be found in three boxes, located between the air filter and the engine. These fuses protect the following functions:

- 1.) Cab; 100 A fuse (1).
- 2.) Main system; 80 A fuse (2).
- 3.) Engine starter motor; 50 A fuse (3).
- 4.) Engine ECU; 30 A fuse (4).

An additional 3 A fuse (5) located inside the adjacent box protects the engine control unit control circuit.

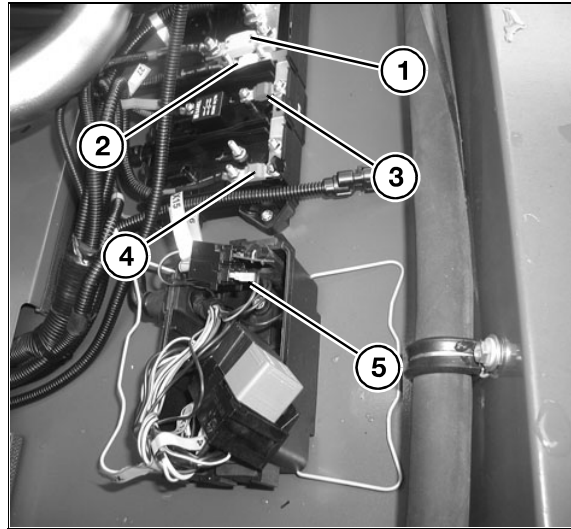

Fig. 49

**Engine circuit fuse**

Fig. 50

A 250 A fuse, located near the starter motor, protects the battery charging circuit.

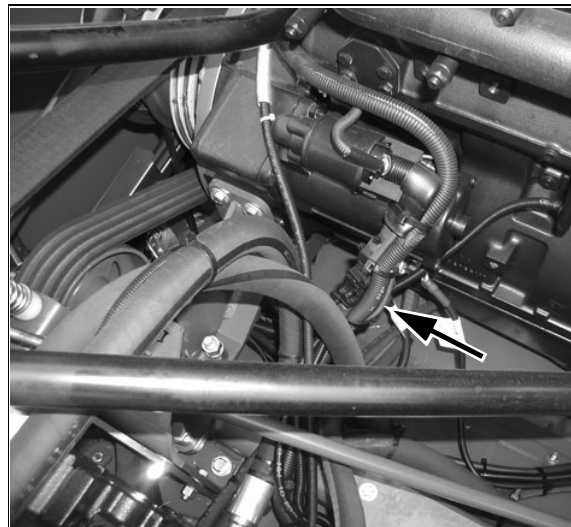

Fig. 50

**Thermal starter circuit fuse**

Fig. 51

A 250 A fuse, located between the starter motor and the control relay, protects the entire thermal starter electrical circuit.

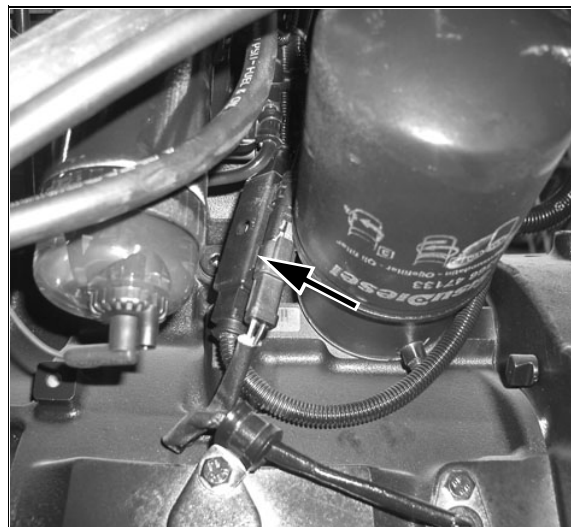

Fig. 51

**8.3 SEPARATION AND CLEANING**

<b>PROBLEM</b>	<b>CAUSE</b>	<b>REMEDY</b>	<b>DESCRIPTION</b>	
<b>Grain loss from the straw walkers.</b>	Straw walkers overloaded due to too high forward speed.	Reduce forward speed to reduce the crop volume in the combine.  Increase cylinder speed and reduce concave clearance for easier separation through the centrifugal action of the cylinder.	-  <b>page 4-14</b>	
	Straw walkers overloaded due to excessive straw damage.	Slightly reduce the cylinder speed in relation to the basic setting and increase the concave clearance.  Fit low type straw risers.  Raise the curtain.	<b>page 4-12</b>  <b>page 4-23</b>  <b>page 4-23</b>  <b>page 4-12</b>	
	Crop is too wet and weed-infested.	Fit high type straw risers.  Wait until the crop is ripe.	<b>page 4-23</b>  -	
	The straw walker grid is clogged and does not let the threshed grains pass through.	Clean the straw walker grid.  Fit low type straw risers.	-  <b>page 4-23</b>	
	The concave is clogged and the grains are thrown onto the straw walkers.	Clean the concave thoroughly.	-	
	Broken curtain.	Replace the broken curtain.	-	
	Incorrect position of the concave.	Make sure the concave is parallel with the cylinder.	<b>page 4-14</b>	
	<b>Excess straw damage.</b>	The cylinder speed is too high.	Reduce the cylinder speed.	<b>page 4-12</b>
		The cylinder to concave clearance is too narrow.	Increase the clearance until optimum threshing is achieved.	<b>page 4-14</b>

# 10. OPTIONAL EQUIPMENT

## GENERAL SPECIFICATIONS OF THE ACCESSORIES

The machine has been designed to operate in a wide variety of crops and conditions.

However, in certain cases it may be necessary to fit additional accessories to improve machine performance and adapt the machine to special crops or harvesting conditions.

In general it is important to be aware that:

- a.) When using non-genuine equipment such as tables, straw choppers and other equipment, it must be CE-certified to comply with safety regulations. The use of the non-genuine equipment may involve functional failures and reliability problems with the combine. AGCO disclaims all liability to any claim resulting from the fitting of non-genuine tables, equipment or accessories.
- b.) The optional equipment listed below may be included as standard for specific countries.
- c.) In other countries some of these accessories may not be available.
- d.) **All optional equipment must be installed by your Dealer's skilled staff according to the manufacturer's instructions. The invoice provided by your Dealer documents the use of skilled staff.**

## AUXILIARY TABLE LIFTING RAM WITH SWITCH ON CONTROL PANEL

Fig. 1 – Fig. 3

The auxiliary lifting ram (1) must be used when fitting cutting tables or maize headers with genuine or non-genuine accessories increasing the weight of the table.

**NOTE:** For further information, contact your area Dealer.

The auxiliary lifting ram is engaged with the switch (2) on the control panel, which controls the solenoid valve (3).

This switch is required to avoid removing the auxiliary lifting ram when the Terra Control system is used.

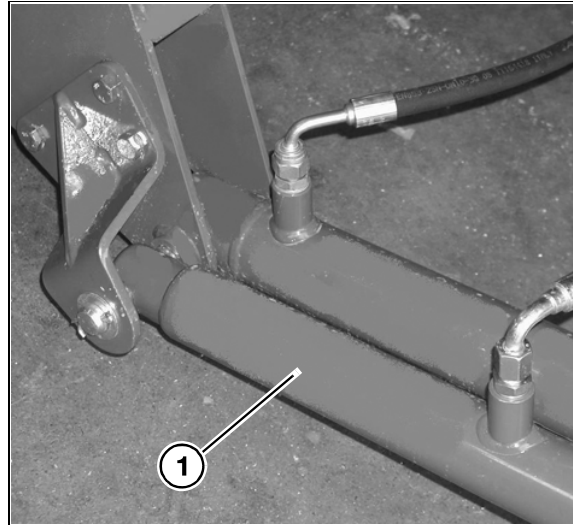

Fig. 1

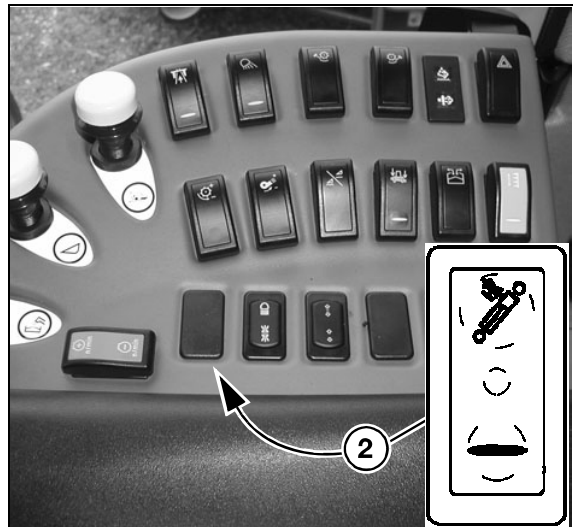

Fig. 2



Fig. 3

## ACCESS TO STRAW CHOPPER ROTOR

Fig. 28

If the straw chopper is blocked or if repairs are to be carried out on the rotor, proceed as follows:

- 1.) Switch off the engine and wait until the straw chopper rotor has come to a complete stop.
- 2.) Using the lever (4 Fig. 25), disengage the deflector plate (1) (swathing).
- 3.) Release the catches (2) on both sides of the deflector plate. Turn up the hatch (3) and lock it in open position using the rod (4).

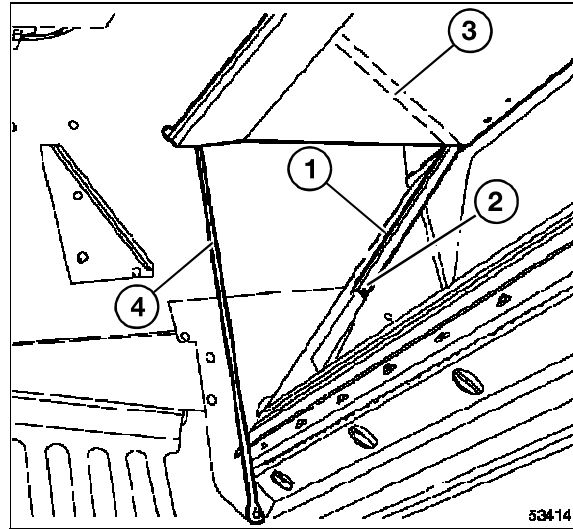

Fig. 28

## STRAW CHOPPER ROTOR KNIVES

Fig. 29

The rotor blades (1) have two cutting edges. When worn they can be reversed, whereas when damaged they need replacement. Proceed as follows:

- 1.) Remove the screw (2), taking care not to lose the two spacers and the washers.
- 2.) Reverse the knife or replace it with a new one.
- 3.) Fit the screw (2) on the right-hand side (in driving direction); the nut (3) must be on the left-hand side (towards the clutch).
- 4.) Tighten the nut (2) by a torque of 64 Nm.

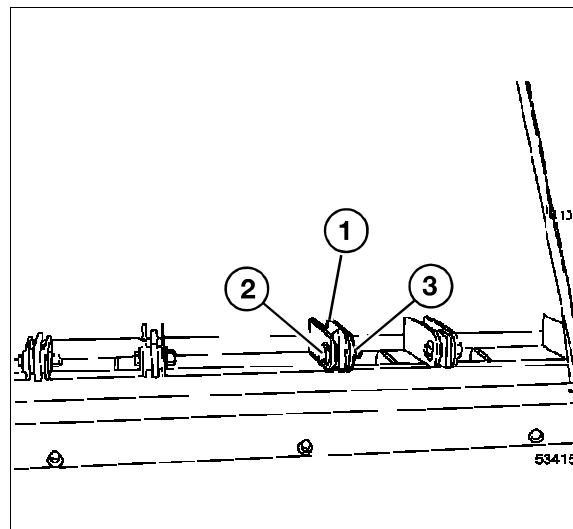

Fig. 29

**NOTE:** When replacing one blade, the diametrically opposite blade must also be replaced to prevent rotor unbalance.

# 11. TECHNICAL SPECIFICATIONS

**NOTE:** The following specifications are approximate and may vary depending on combine type and/or harvesting conditions.

## 11.1 WHEELS AND TYRES



**CAUTION:** Only tyres specified by the manufacturer are approved. If non-genuine tyres are used, they must have the same size and strength as the genuine tyres (for diagonal tyres, see ply rating "PR"; for radial tyres, see load capacity - e.g. 172 A8). Always observe the recommended tyre pressure. The tyre pressure must be checked with attached table, lifted from the ground.

Use only genuine rims with prescribed tyres. Only the prescribed tyre and rim combinations have been approved according to machine weight, width and speed limits in road transport.

The mounting of the tyres must comply with local regulations on max. permissible width on public roads.

### WHEEL BOLT TORQUES

Front wheel bolts	700 Nm (71 kgm)
Rear wheel bolts	304 Nm (31 kgm)



**CAUTION:** Road transport with full grain tank is not allowed.

### TYRE LOAD CAPACITY

Tyre	Load index	Tyre load capacity (kg) at 25 km/h Travelling on roads (°)	Tyre load capacity (kg) at 10 km/h In the field (*)
650/75 R32	172 A8	6995	8940
710/75 R32	177 A8	8105	10765
800/65 R32	172 A8	6995	10420
460/70 R24	152 A8	3940	5325
540/65 R24	146 A8	3330	5010

(\*) at the pressure indicated on the following page

(°) according to ETRTO.

## TECHNICAL SPECIFICATIONS

	5255 L	6275 L
<b>ENGINE</b>		
- Make .....	AGCO SISU Power	
- Type .....	66 AWI 746	74 AWI 747
- Cylinders ..... units	6	
- Cubic capacity ..... cm <sup>3</sup>	6596	7365
- Bore ..... mm	108	
- Stroke ..... mm	120	134
- Rotation direction (from the flywheel) .....	anti-clockwise	
- Idle speed ..... rpm	2200 ± 50	
- Full-load speed ..... rpm	2200	
- Maximum power engine speed ..... rpm	2000	
- Maximum power (ECE 120 R) ..... kW	179	203
- Nominal power (at 2200 rpm) ..... kW	175	198
- Engine sump capacity without filters ... litres	29,5	
- Engine sump capacity with filters ..... litres	32	
- DEF tank capacity ..... litres	80	
- Fuel tank capacity ..... litres	620	
<b>RADIATOR</b>		
- Circuit capacity ..... litres	40	
<b>ELECTRICAL COMPONENTS</b>		
<b>BATTERY</b>		
- Type 12 V ..... A/h	200	
- Peak current ..... A	1200	
<b>STARTER MOTOR</b>		
- Type .....	12V	
<b>ALTERNATOR</b>		
- Type .....	12V	
- Charging capacity ..... A	150	
<b>TRANSMISSION</b>		
- Transmission type .....	with front engagements	
- Gears ..... no.	4	
Speed (forward movement and in reverse) with 650/75 R32, 710/75 R32 and 800/65 R32 tyres		
- 1st gear (working) ..... km/h	0 - 3,7	
- 2nd gear (working) ..... km/h	0 - 7,8	
- 3rd gear (working) ..... km/h	0 - 15,1	
- 4th gear (working) ..... km/h	-	

CLICK HERE TO **DOWNLOAD** THE COMPLETE MANUAL

- Thank you very much for reading the preview of the manual.
- You can download the complete manual from: [www.heydownloads.com](http://www.heydownloads.com) by clicking the link below



- Please note: If there is no response to CLICKING the link, please download this PDF first and then click on it.

CLICK HERE TO **DOWNLOAD** THE COMPLETE MANUAL