

JT25

Tier 4 & LRC (Tier 3)

Operator's Manual







CLICK HERE TO **DOWNLOAD** THE COMPLETE MANUAL

- Thank you very much for reading the preview of the manual.
- You can download the complete manual from: www.heydownloads.com by clicking the link below



- Please note: If there is no response to CLICKING the link, please download this PDF first and then click on it.

CLICK HERE TO **DOWNLOAD** THE COMPLETE MANUAL

	Specifications machine specifications including weights, measurements, power ratings, and fluid capacities	213
	Support the warranty policy for this machine, and procedures for obtaining warranty consideration and training	219
	Service Record a record of major service performed on the machine	223
	Appendix additional information about Ditch Witch® equipment	225

12

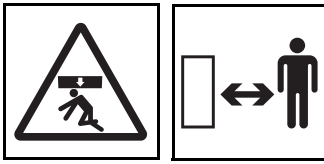

⚠ WARNING Crushing weight could cause death or serious injury. Stay away. 275-326, 701-326

13

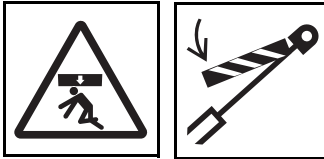

⚠ WARNING Crushing weight. Place cylinder lock on extended cylinder and secure. 273-231, 273-413

14



Emergency exit. Push window out to exit cab when door is blocked or inoperable. 270-6314

15



⚠ CAUTION Fall or equipment damage possible. Do not step on this area. 273-128

16



⚠ WARNING Jobsite hazards could cause death or serious injury. Use correct equipment and work methods. Use and maintain proper safety equipment. 274-724 (2P)

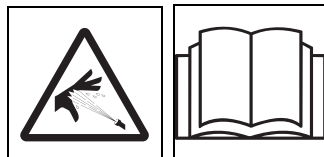

17

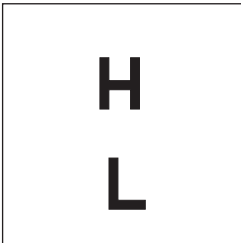
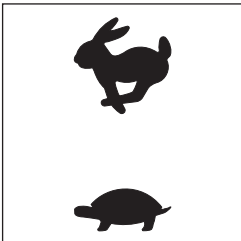

⚠ WARNING Pressurized fluid or air could pierce skin and cause severe injury. Refer to operator's manual for proper use. 270-6035

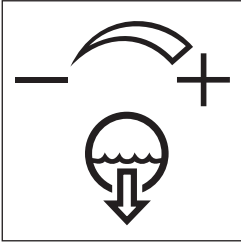
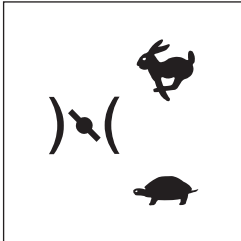
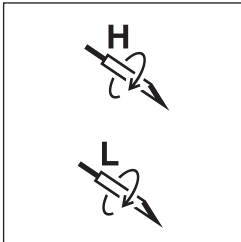
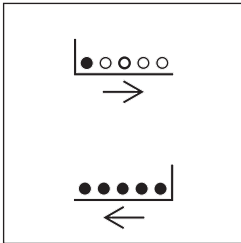
Item	Description	Notes
<p>7. Drive mode switch</p>  <p>c00ic146h.eps</p>	<p>To select normal driving mode (high), move up.</p> <p>To select loading and unloading mode (low), move down.</p>	
<p>8. Throttle switch</p>  <p>c00ic042h.eps</p>	<p>To increase engine speed, move up.</p> <p>To decrease engine speed, move down.</p> <p>Release switch to stop speed adjustment.</p>	<p>IMPORTANT: Switch only works when controller is in the ready mode (green LED blinking) and at least one operator presence switch is pressed.</p>

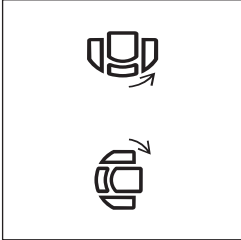
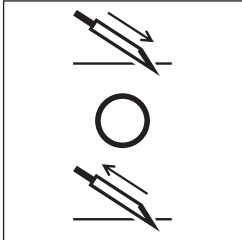
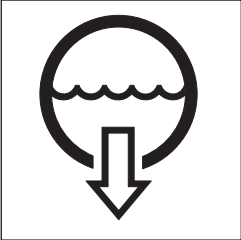
Item	Description	Notes
<p>10. Fluid flow control</p>  <p>c00ic045h.eps</p>	<p>To increase flow, turn clockwise.</p> <p>To decrease flow, turn counterclockwise.</p>	
<p>11. Engine throttle switch</p>  <p>c00ic243h.eps</p>	<p>To increase speed, press top.</p> <p>To enable autothrottle mode, leave switch in top position.</p> <p>To disable autothrottle mode, return switch to center after desired speed is reached.</p> <p>To decrease speed, press bottom.</p>	<p>Autothrottle mode slows the engine to low throttle after 15 seconds of inactivity involving thrust, rotation, drilling fluid flow, or pipeloader functions. To return to high speed, activate thrust, rotation, drilling fluid, or an add/remove pipe cycle.</p>
<p>12. Two-speed rotation switch</p>  <p>c00ic610h.eps</p>	<p>To rotate in high speed, press top.</p> <p>To rotate in low speed, press bottom.</p>	
<p>13. Shuttle stop switch</p>  <p>c00ic611h.eps</p>	<p>To lower shuttle stop, push up.</p> <p>To raise shuttle stop, pull down.</p>	<p>IMPORTANT: Look at pipe row indicator on drill frame to see which row shuttles will stop under.</p>

Item	Description	Notes
<p>6. Operator's station pivot control switch</p>  <p>c00ic624h.eps</p>	<p>To pivot into drilling position, press top.</p> <p>To pivot into transport position, press bottom.</p>	<p>NOTICE: Move carriage only when operator's station is in drilling position.</p>
<p>7. Add pipe/manual/ remove pipe switch</p>  <p>c00ic031h.eps</p>	<p>To select "add pipe" automated pipeloader function, press top.</p> <p>To use manual pipeloader controls, move to center.</p> <p>To select "remove pipe" automated pipeloader function, press bottom.</p>	<p>See "Add Pipe" on page 106.</p> <p>See "Remove Pipe" on page 116.</p>
<p>8. Drilling fluid pump switch</p>  <p>c00ic060h.eps</p>	<p>To turn on, press once.</p> <p>To turn off, press once.</p>	
<p>9. Drilling fluid quick fill switch</p>  <p>c00ic059h.eps</p>	<p>For full pump flow to fill pipe with fluid, press and hold.</p> <p>To return fluid flow to flow control setting, release.</p>	<p>IMPORTANT: Overrides fluid control settings for full pump flow. Also overrides temporary fluid shutdown when front wrench is closed.</p>

Front

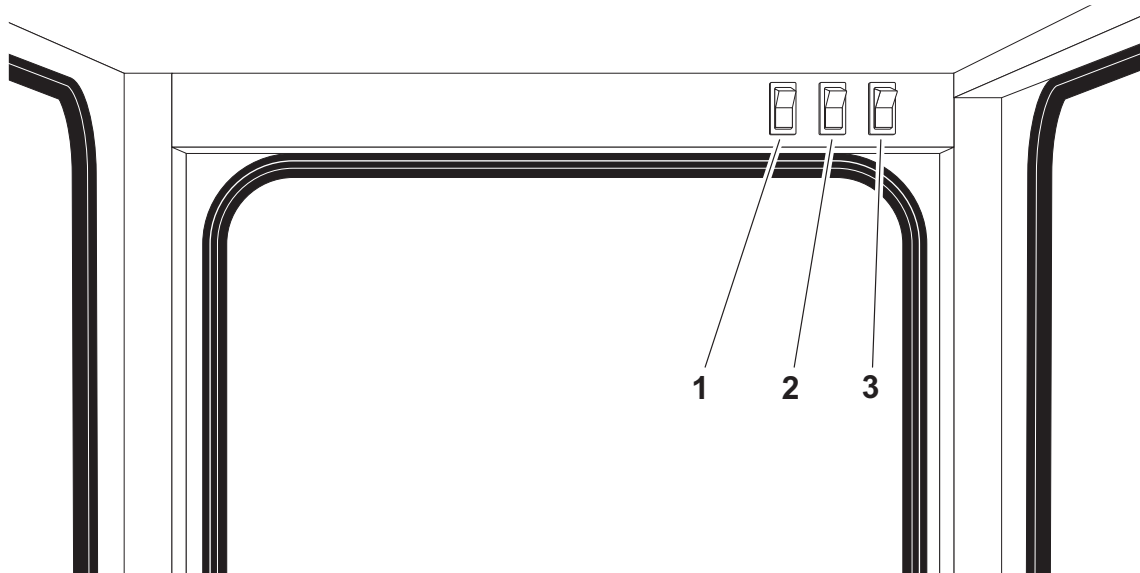

j29om003t.eps

- 1. Washer switch
- 2. Wiper switch

- 3. Worklight switch

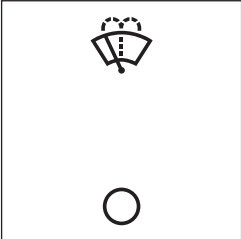
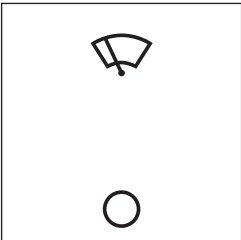
Item	Description	Notes
<p>1. Washer switch</p>  <p>c00ic630h.eps</p>	<p>To spray washer fluid, press top.</p> <p>To stop, press bottom.</p>	
<p>2. Wiper switch</p>  <p>c00ic629h.eps</p>	<p>To start wiper blade, press top.</p> <p>To stop wiper blade, press bottom.</p>	

Prepare Jobsite 83

- Mark Bore Path83
- Prepare Entry Point.83

Check Supplies and Prepare Equipment 84

- Check Supplies84
- Prepare Equipment85
- Assemble Accessories86

IMPORTANT: A shallow entry pitch (A1) allows you to reach horizontal sooner and with less bending. Increasing entry pitch (A2) makes minimum setback longer and deeper.

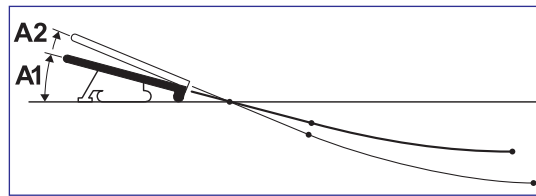

j07om007c.eps

Minimum Setback

Setback is the distance from the entry point to where pipe becomes horizontal (B1).

NOTICE: If setback is too small (B2), you will exceed bend limits and damage the pipe.

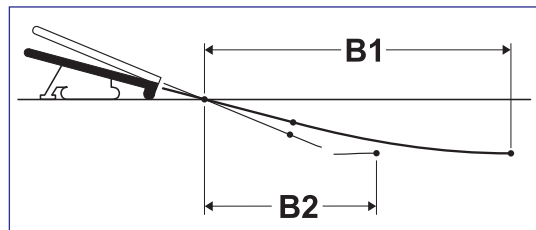

j07om008c.eps

Minimum Depth

Because you must bend pipe gradually, entry pitch and bend limits determine how deep the pipe will be when it becomes horizontal. This is called the **minimum depth**.

- To reduce minimum depth (D1), reduce entry pitch. This also decreases setback.
- To increase minimum depth (D2), increase entry pitch. This also increases setback.

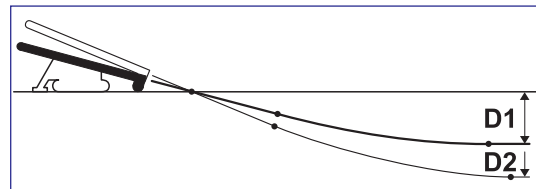

j07om009c.eps

Shut Down Unit

1. Stop track movement.
2. Lower drill frame and stabilizers to the ground.
3. Run engine at high throttle, no load, for one minute, then low throttle, no load for two minutes to cool.
4. Turn ignition switch to STOP.
5. Remove key.

Start System

1. Start drilling unit and remote fluid unit. Allow both engines to warm up.

IMPORTANT: Ensure that mixture of drilling fluid matches drilling conditions. See "Drilling Fluid" on page 129.

2. Enable DrillLok™ mode if desired. See "DrillLok™" on page 133.
3. Press top of drilling unit throttle switch. Engine will increase to full throttle. If you do not want to use autothrottle mode (traditional controls only), return switch to center position.

Prime Drilling Fluid Pump

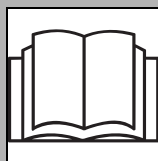

WARNING Read operator's manual. Know how to use all controls. Your safety is at stake. 273-475.

To help avoid injury: Prime the drilling fluid pump before use to reduce flow fluctuations, which make it difficult to control the washwand.

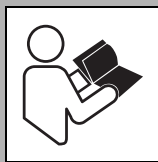

WARNING Pressurized fluid or air could pierce skin and cause severe injury. Refer to operator's manual for proper use. 270-6035

Prime drilling fluid pump each time tank is changed. To prime the pump:

1. Fill drilling fluid hose and connect hose to unit.
2. Operate mixing/transfer pump at full speed for 1 - 3 minutes to discharge air from system.
3. Return mixing/transfer pump to normal operating speed and continue the bore.
4. If drilling fluid pressure surges are observed, repeat step 2.

Use AutoCarve

AutoCarve helps the operator change direction when thrust stalls in difficult soil conditions. AutoCarve rotates the bit clockwise and counterclockwise to grind away soil, clearing a path to improve steering through tough formations.

Movement	Description
alternating clockwise and counterclockwise rotation	Enables the downhole tool to carve tough soil formations. Rotation speed can be adjusted during autocarving. NOTICE: To reduce the chance of unthreading pipe sections downhole, rotation pressure is limited during counterclockwise rotation; however, the operator should monitor carve operation and adjust thrust and rotation to prevent unthreading.
carve window	The range of alternating rotation.
thrust	In autocarve mode, initial thrust speed is very slow or fully stopped. Adjust speed anytime during carving.
pullback	Thrust and rotation operate normally when thrust is pulled rearward. High-speed pullback is not available in autocarve mode.

CLICK HERE TO **DOWNLOAD** THE COMPLETE MANUAL

- Thank you very much for reading the preview of the manual.
- You can download the complete manual from: www.heydownloads.com by clicking the link below



- Please note: If there is no response to CLICKING the link, please download this PDF first and then click on it.

CLICK HERE TO **DOWNLOAD** THE COMPLETE MANUAL

Drill Pipe 141

- Perform Regular Drill Pipe Care141
- Use Drill Pipe Correctly142

Pipe Boxes 144

- Remove/Install Pipe Box144
- Add/Remove Single Pipe146

Wireless Ground Drive Control 150

- Before Each Use150
- Operation151
- Troubleshooting152

Cruise Control 153

- Engage153
- Adjust Settings154
- Override154
- Disengage154
- Resume154

Diagnostic Codes 155

- Electronic Controlled Engine Overview.155
- Reading Engine Diagnostic Codes155
- Reading Machine Diagnostic Codes156
- Code Severity Levels156
- Machine Diagnostic Codes157

Bentonite

Bentonite is a dry powder. When properly mixed with water, it forms a thin cake on bore walls, lubricating the bore, keeping it open, and holding fluid in the bore.

Some things to remember when mixing bentonite:

- Use clean water free of salt, calcium, or excessive chlorine.
- Use water with pH level between 9 and 10.
- Use water with hardness of less than 120 ppm.
- Do not use bentonite containing sand.
- Mix bentonite thoroughly or it will settle in tank.
- Do not mix bentonite to a funnel viscosity of over 50.

For information on measuring funnel viscosity, see "Funnel Viscosity" on page 132.

Mixtures

Bentonite does not mix well in water containing polymer. To use both, mix bentonite first, then add polymer. When adding other products follow the order listed below.

IMPORTANT:

- If chemicals are added in the wrong order, they will not mix properly and will form clumps.
- If tank contains bentonite/polymer mix and more drilling fluid is needed, completely empty tank and start with fresh water before mixing another batch.

General mixing order:

1. Soda ash
2. Bentonite
3. Polymer
4. Con Det[®]

Bore-Gel[®] contains premixed bentonite, polymer, and soda ash. Use approximately 15 lb/100 gal (7 kg/380 L) in normal drilling conditions, up to 45 lb/100 gal (21 kg/380 L) in sand or gravel and up to 50 lb/100 gal (23 kg/380 L) in rock.

To Join

1. Scribe straight line across joint on both sides of separating line (A).
2. Scribe second line (B) on moveable side of joint in the opposite direction of tightening action away from first line the distance indicated below.
 - Power Pipe[®]: 3/8" (9.5 mm)
 - Power Pipe[®] Forged: 1/4" (6.4 mm)
 - Thread-in backreamer accessories: 5/8" (15.9 mm)
3. Turn handle until second line (B) meets first (A).
4. Turn handle opposite direction two turns to relieve pressure.
5. Remove quick wrench components.

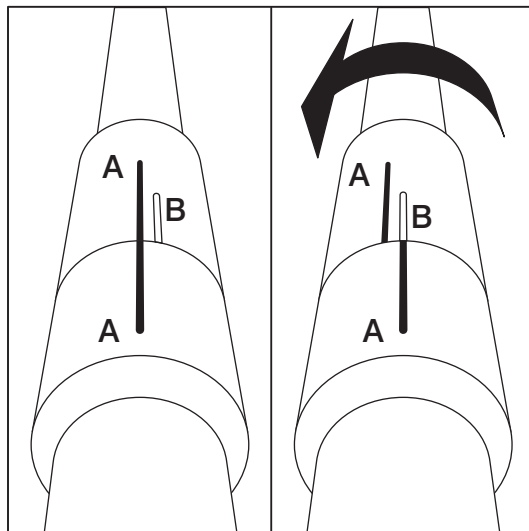
**To Break**

NOTICE: Ensure that engine is not on or DrillLok™ has disabled the unit before breaking joints.

1. Turn handle until joint is broken.
2. Turn handle opposite direction two turns to relieve pressure.
3. Remove quick wrench components.

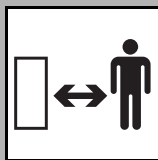

Crushing weight could cause death or serious injury. Stay away.

To help avoid injury:

- Drill pipe is heavy. Have enough people on hand to manually add or remove single pipe to pipe box.
- Do not attempt to move shuttles until everyone is at least 10 ft (3 m) away from machine.

11. Press top of shuttle lockout switch to prevent shuttle operation.
12. Remove pipe from auxiliary pipe loaders and store properly.
13. Repeat steps 7-12 to unload remaining added drill pipe.
14. After all added drill pipe is unloaded with auxiliary pipe loaders:
 - Close both auxiliary pipe loaders.
 - Remove pipe stop and store it on shuttle guard.
15. Press bottom of shuttle lockout switch to allow shuttle operation. Move at least 10 ft (3 m) away from drill.
16. Finish loading remaining drill pipe into row 5 using standard procedure. See "Remove Pipe" on page 116.

Wireless Ground Drive Controller

Before each use

1. Check transmitter unit battery status. Replace batteries if necessary. See page 209.
2. Ensure USB key (shown) is installed. This key is a lockout feature to prevent unauthorized use.

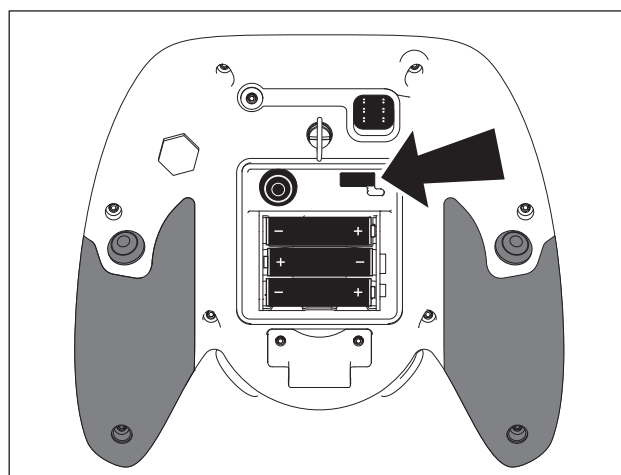

Remote_USB.eps

Code	Display	Condition	Result	Severity
095	PIPE PROTOCOL	pipe controller has an incorrect protocol message	code is stored	non-essential
096	MAIN NG FAIL	main controller has detected node guard timeout	controller runs in main service mode	essential
097	PIPE NG FAIL	pipe controller has missed a node guard from the master	controller runs in pipeloader service mode	essential
098	MAIN LOG FAIL	pipe controller has had an internal software failure	controller runs in main service mode	essential
099	PIPE LOG FAIL	pipe controller has had an internal software failure	controller runs in pipeloader service mode	essential
111	TETH NG FAIL	tether controller has missed a node guard from the main controller	drive is blocked	essential
112	ESID NG FAIL	ESID controller has missed a node guard from the main controller	code is stored	non-essential
113	ICTR NG FAIL	machine display has missed a node guard from the main controller	code is stored	non-essential
131	THREAR HSW	no continuity to thrust rear home switch	add pipe and remove pipe are blocked	non-essential
132	THFRNT HSW	no continuity to thrust front home switch	add pipe and remove pipe are blocked	non-essential
133	SHUTTL HSW	no continuity to shuttle home switch	add pipe and remove pipe are blocked	non-essential
134	FWRNCH PSW	no continuity to front wrench switch	add pipe and remove pipe are blocked	non-essential
136	TH REAR STOP	no continuity to thrust rear stop switch	add pipe and remove pipe are blocked	non-essential
137	PIPE UP PSW	no continuity to pipe up switch	pipe box movement is blocked and code is stored	non-essential
138	FRONT BOX HSW	no continuity to front pipe box switch	code is stored	non-essential
139	REAR BOX HSW	no continuity to rear pipe box switch	code is stored	non-essential
141	ROTATE POS	no continuity to rotation position sensor	code is stored	non-essential
143	DFLUID GPM	no continuity to drilling fluid speed sensor	code is stored	non-essential

Startup/10 Hour

Location	Task	Notes
DRILLING UNIT	Check track tension and condition	
	Check fuel filter water separator	
	Check engine oil level	DEO
	Check fluid pump piston seals	
	Check engine coolant level	DEAC
	Check hydraulic hoses	
	Check hydraulic fluid level	THF
	Check fluid pump oil level	PTF
	Test control switches	
	Check pipe auto lubricator spray nozzle	
	Check pipe auto lubricator TJC level	TJC
	Clean drilling fluid Y-strainer	
	Inspect crankcase breather tube	
	Empty dust ejector valve	

Check Rotation Gearbox Oil Level

IMPORTANT: Drill frame must be level for accurate reading.

Check rotation gearbox oil level every 50 hours.

Add MPL through plug (1) to level of sight plug (2) as needed.

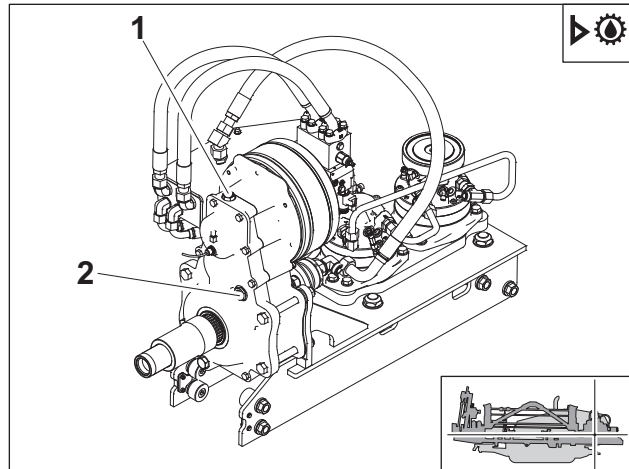

j37om042h.eps

Inspect Thrust Rollers

Inspect thrust rollers (at each end of carriage) every 50 hours. Clean or replace if they do not turn freely.

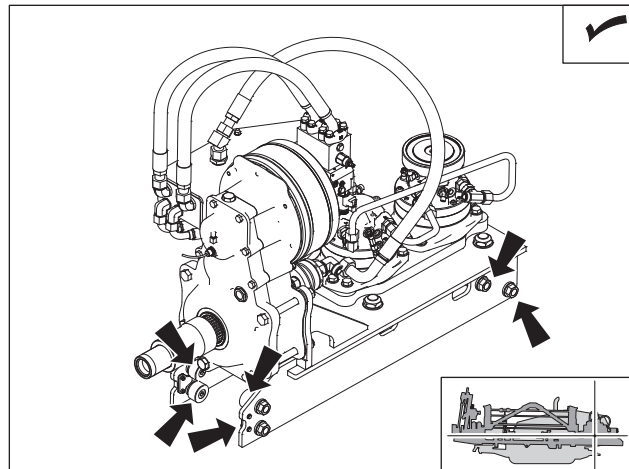

j37om045h.eps

Drain Water from Hydraulic Tank

Drain water out of tank every 50 hours. To drain, turn plug (shown) slightly until water comes out. After all water has drained, tighten plug.

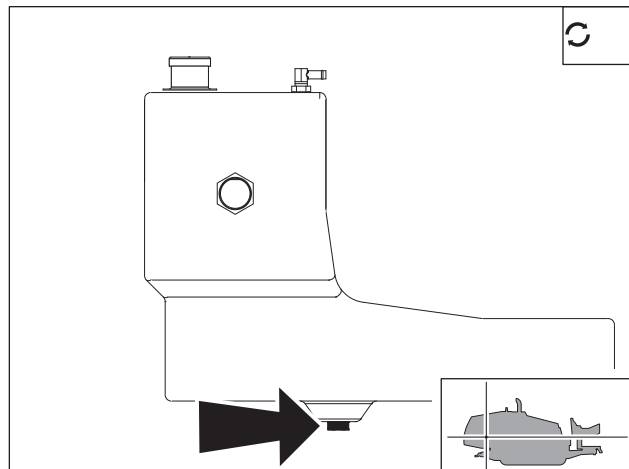

j37om032h.eps

2000 Hour

Location	Task	Notes
DRILLING UNIT	Change engine coolant	DEAC
	Change fluid pump oil	PTF
	Replace crankcase breather filter	Tier 4 only

Drilling Unit

Change Engine Coolant

Drain cooling system at drain (3) every two years or 2000 hours. Add approved coolant according to instructions below. Refill capacity is 24 qt (22.7 L) for Tier 4 units and 23 qt (21.8 L) for LRC (Tier 3) units.

NOTICE:

- The use of non-approved coolant may lead to engine damage or premature engine failure and will void engine warranty.
- See "Approved Coolant" on page 176 for list of approved coolants.
- Use only distilled water for mixing coolants. Do not use tap water.

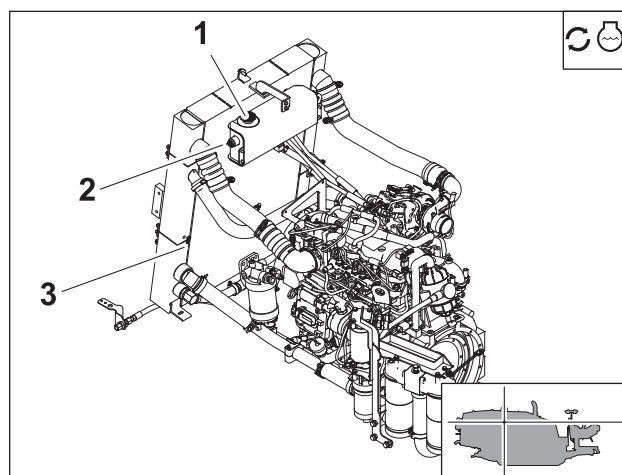

j49om023h.eps

To fill:

1. Add coolant at radiator fill (1) at a rate of 3 gpm (11.4 L/min) or less until full.
2. Run engine with thermostat open (>195°F/90°C engine temperature) for several minutes.
3. Stop engine and let it cool.
4. Maintain coolant level at halfway point on sight glass (2).

Charge Battery



⚠ WARNING Explosion possible. Serious injury or equipment damage could occur. Follow directions carefully.

To help avoid injury:

- Use a single 12V maximum source for charging. Do not connect to rapid chargers or dual batteries.
- Use caution and wear personal protective equipment such as safety eyewear, when charging or cleaning battery.
- Keep sparks, flames, and any ignition source away from batteries at all times. Internal contents are extremely hazardous. Leaking fluid is corrosive. Battery may be explosive at higher temperatures.
- NEVER lean over battery when making connections.
- Do not allow vehicles to touch when charging.
- Do not attempt to charge a battery that is leaking, bulging, heavily corroded, frozen, or otherwise damaged.
- NEVER short-circuit battery terminals for any reason or strike battery posts or cable terminals.
- Refer to MSDS for additional information regarding this battery.

Before You Start

Electronic components can be easily damaged by electrical surges. Jump starting can damage electronics and electrical systems, and is not recommended. Try to charge the battery instead. Use quality large diameter jumper cables capable of carrying high currents (400 amps or more). Cheap cables may not allow enough current flow to charge a dead/discharged battery.

Read all steps thoroughly and review illustration before performing procedure.

Warranty

Ditch Witch® Equipment and Replacement Parts Limited Warranty Policy

Subject to the limitation and exclusions herein, free replacement parts will be provided at any authorized Ditch Witch dealership for any Ditch Witch equipment or parts manufactured by The Charles Machine Works, Inc. (CMW) that fail due to a defect in material or workmanship within one (1) year of first commercial use. Free labor will be provided at any authorized Ditch Witch dealership for installation of parts under this warranty during the first year following "initial commercial" use of the serial-numbered Ditch Witch equipment on which it is installed. The customer is responsible for transporting their equipment to an authorized Ditch Witch dealership for all warranty work.

Exclusions from Product Warranty

- All incidental or consequential damages.
- All defects, damages, or injuries caused by misuse, abuse, improper installation, alteration, neglect, or uses other than those for which products were intended.
- All defects, damages, or injuries caused by improper training, operation, or servicing of products in a manner inconsistent with manufacturer's recommendations.
- All engines and engine accessories (these are covered by original manufacturer's warranty).
- Tires, belts, and other parts which may be subject to another manufacturer's warranty (such warranty will be available to purchaser).
- ALL IMPLIED WARRANTIES NOT EXPRESSLY STATED HEREIN, INCLUDING ANY WARRANTY OF FITNESS FOR A PARTICULAR PURPOSE AND MERCHANTABILITY.

IF THE PRODUCTS ARE PURCHASED FOR COMMERCIAL PURPOSES, AS DEFINED BY THE UNIFORM COMMERCIAL CODE, THEN THERE ARE NO WARRANTIES WHICH EXTEND BEYOND THE FACE HEREOF AND THERE ARE NO IMPLIED WARRANTIES OF ANY KIND WHICH EXTEND TO A COMMERCIAL BUYER. ALL OTHER PROVISIONS OF THIS LIMITED WARRANTY APPLY INCLUDING THE DUTIES IMPOSED.

Ditch Witch products have been tested to deliver acceptable performance in most conditions. This does not imply they will deliver acceptable performance in all conditions. Therefore, to assure suitability, products should be operated under anticipated working conditions prior to purchase.

Defects will be determined by an inspection within thirty (30) days of the date of failure of the product or part by CMW or its authorized dealer. CMW will provide the location of its inspection facilities or its nearest authorized dealer upon inquiry. CMW reserves the right to supply remanufactured replacement parts under this warranty as it deems appropriate.

Extended warranties are available upon request from your local Ditch Witch dealer or CMW.

Some states do not allow exclusion or limitation of incidental or consequential damages, so above limitation of exclusion may not apply. Further, some states do not allow exclusion of or limitation of how long an implied warranty lasts, so the above limitation may not apply. This limited warranty gives product owner specific legal rights and the product owner may also have other rights which vary from state to state.

For information regarding this limited warranty, contact CMW's Product Support department, P.O. Box 66, Perry, OK 73077-0066, or contact your local dealer.

J1939_SPN	J1939_FMI	Cummins' Fault Code	Circuit	Cummins Detailed Description	JT25/JT30	JT60/JT100
3363	4	1684	Aftertreatment 1 Diesel Exhaust Fluid Tank Heater	Voltage below normal, or shorted to low source	X	X
3363	7	3242	Aftertreatment 1 Diesel Exhaust Fluid Tank Heater	Mechanical system not responding or out of adjustment	X	X
3363	16	1713	Aftertreatment 1 Diesel Exhaust Fluid Tank Heater	Data Valid But Above Normal Operating Range , Moderately Severe Level	X	X
3363	18	1712	Aftertreatment 1 Diesel Exhaust Fluid Tank Heater	Data Valid But Below Normal Operating Range , Moderately Severe Level	X	X
3364	2	3878	Aftertreatment Diesel Exhaust Fluid Quality	Data erratic, intermittent or incorrect	X	X
3364	3	1686	Aftertreatment Diesel Exhaust Fluid Quality Sensor Circuit	Voltage above normal, or shorted to high source	X	X
3364	4	1685	Aftertreatment Diesel Exhaust Fluid Quality Sensor Circuit	Voltage below normal, or shorted to low source	X	X
3364	5	4741	Aftertreatment Diesel Exhaust Fluid Quality Sensor Circuit	Current below normal or open circuit	X	X
3364	6	4742	Aftertreatment Diesel Exhaust Fluid Quality Sensor Circuit	Current above normal or grounded circuit	X	X
3364	7	3876	Aftertreatment Diesel Exhaust Fluid Quality Sensor	Mechanical system not responding or out of adjustment	X	X
3364	9	3868	Aftertreatment Diesel Exhaust Fluid Quality	Abnormal update rate	X	X
3364	10	4277	Aftertreatment Diesel Exhaust Fluid Quality	Abnormal Rate of Change	X	X
3364	11	1715	Aftertreatment Diesel Exhaust Fluid Quality	Root Cause Not Known	X	X
3364	12	3877	Aftertreatment Diesel Exhaust Fluid Quality Sensor	Bad intelligent device or component		X
3364	13	1714	Aftertreatment Diesel Exhaust Fluid Quality	Out of Calibration	X	X
3364	15	4842	Aftertreatment Diesel Exhaust Fluid Quality	Data Valid But Above Normal Operating Range , Least Severe Level	X	X
3364	18	3867	Aftertreatment Diesel Exhaust Fluid Quality	Data Valid But Below Normal Operating Range , Moderate Severe Level	X	X
3364	19	4241	Aftertreatment Diesel Exhaust Fluid Quality	Received Network Data In Error	X	X
3509	3	386	Sensor Supply 1 Circuit	Voltage above normal, or shorted to high source	X	X
3509	4	352	Sensor Supply 1 Circuit	Voltage below normal, or shorted to low source	X	X
3510	3	227	Sensor Supply 2 Circuit	Voltage above normal, or shorted to high source	X	X
3510	4	187	Sensor Supply 2 Circuit	Voltage below normal, or shorted to low source	X	X
3511	3	239	Sensor Supply 3 Circuit	Voltage above normal, or shorted to high source	X	X
3511	4	238	Sensor Supply 3 Circuit	Voltage below normal, or shorted to low source	X	X
3512	3	2185	Sensor Supply 4 Circuit	Voltage above normal, or shorted to high source	X	X
3512	4	2186	Sensor Supply 4 Circuit	Voltage below normal, or shorted to low source	X	X
3513	3	1695	Sensor Supply 5	Voltage above normal, or shorted to high source	X	X
3513	4	1696	Sensor Supply 5	Voltage below normal, or shorted to low source	X	X
3514	3	515	Sensor Supply 6 Circuit	Voltage above normal, or shorted to high source	X	X
3514	4	516	Sensor Supply 6 Circuit	Voltage below normal, or shorted to low source	X	X
3515	5	4743	Aftertreatment 1 Diesel Exhaust Fluid Temperature 2 Sensor Circuit	Current below normal or open circuit	X	X
3515	6	4744	Aftertreatment 1 Diesel Exhaust Fluid Temperature 2 Sensor Circuit	Current above normal or grounded	X	X
3515	10	4243	Aftertreatment 1 Diesel Exhaust Fluid Temperature 2	Abnormal Rate of Change	X	X
3515	11	4745	Aftertreatment 1 Diesel Exhaust Fluid Temperature 2	Root Cause Not Known	X	X
3521	11	4768	Aftertreatment 1 Diesel Exhaust Fluid Property	Root Cause Not Known	X	X
3597	2	1117	Power Supply Lost With Ignition On	Data erratic, intermittent or incorrect	X	X
3597	12	351	Injector Power Supply	Bad intelligent device or component	X	X
3597	18	1938	ECU Power Output Supply Voltage 1	Data Valid But Below Normal Operating Range , Moderately Severe Level	X	X
3667	2	5221	Engine Air Shutoff Status	Data erratic, intermittent or incorrect		X
3667	3	3139	Engine Air Shutoff Circuit	Voltage above normal, or shorted to high source		X
3667	4	3141	Engine Air Shutoff Circuit	Voltage below normal, or shorted to low source		X
3667	7	4484	Engine Air Shutoff	Mechanical System Not Responding or Out of Adjustment		X
3695	2	4213	Aftertreatment Regeneration Inhibit Switch	Data erratic, intermittent or incorrect	X	X
4094	31	3543	NOx limits exceeded due to Insufficient Reagent Quality	Condition Exists		X
4096	31	3547	Aftertreatment Diesel Exhaust Fluid Tank Empty	Condition Exists	X	X
4185	31	1427	Overspeed Shutdown Relay Driver Diagnostic has detected an error	Condition Exists	X	X
4186	31	1428	Low Oil Pressure (LOP) Shutdown Relay Driver Diagnostic has detected an error	Condition Exists	X	X
4187	31	1429	High Engine Temperature (HET) Shutdown Relay Driver Diagnostic has detected an error	Condition Exists	X	X
4188	31	1431	Pre-Low Oil Pressure Indicator Relay Driver	Pre-Low Oil Pressure Warning Relay Driver Diagnostic has detected an error , Condition Exists	X	X
4223	31	1432	Pre-High Engine Temperature Warning Relay Driver	Pre-High Engine Temperature Warning Relay Driver Diagnostic has detected an error , Condition Exists	X	X
4334	2	3596	Aftertreatment 1 Diesel Exhaust Fluid Pressure Sensor	Data erratic, intermittent or incorrect	X	X
4334	3	3571	Aftertreatment 1 Diesel Exhaust Fluid Pressure Sensor	Voltage above normal, or shorted to high source	X	X
4334	4	3572	Aftertreatment 1 Diesel Exhaust Fluid Pressure Sensor	Voltage below normal, or shorted to low source	X	X
4334	16	3575	Aftertreatment 1 Diesel Exhaust Fluid Pressure Sensor	Data Valid But Above Normal Operating Range	X	X
4334	18	3574	Aftertreatment 1 Diesel Exhaust Fluid Pressure Sensor	Data Valid But Below Normal Operating Range	X	X
4337	10	4249	Aftertreatment 1 Diesel Exhaust Fluid Dosing Temperature	Abnormal Rate of Change	X	X

CLICK HERE TO **DOWNLOAD** THE COMPLETE MANUAL

- Thank you very much for reading the preview of the manual.
- You can download the complete manual from: www.heydownloads.com by clicking the link below



- Please note: If there is no response to CLICKING the link, please download this PDF first and then click on it.

CLICK HERE TO **DOWNLOAD** THE COMPLETE MANUAL