



INDUSTRIAL TRUCK DIVISION



**OPERATORS
MAINTENANCE
PARTS
MANUAL**

**FOR
CY 40 B**

CODE GOV'T 0-202

CLARK EQUIPMENT COMPANY

PUBLISHED BY

TECHNICAL SERVICE DEPARTMENT,
BATTLE, CREEK, MICHIGAN, U.S.A.

476 dump

CLICK HERE TO **DOWNLOAD** THE COMPLETE MANUAL

- Thank you very much for reading the preview of the manual.
- You can download the complete manual from: www.heydownloads.com by clicking the link below



- Please note: If there is no response to CLICKING the link, please download this PDF first and then click on it.

CLICK HERE TO **DOWNLOAD** THE COMPLETE MANUAL

D I M E N S I O N A L
S P E C I F I C A T I O N S

CLARKLIFT® CY- 40

4,000 pounds capacity, 24 inch load center

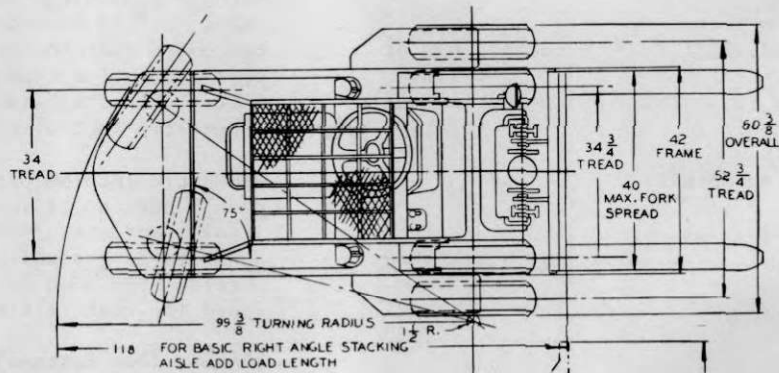

CAPACITY CHART

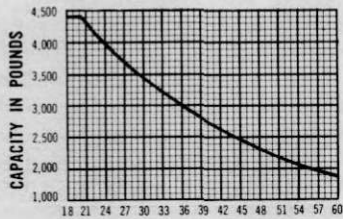

Load center in inches from front face of forks
— Rated capacities shown above are computed with uprights in vertical position. Lifts above 154" maximum fork height, contact factory. Specific capacities will be shown on truck nameplate.

MINIMUM INTERSECTING AISLE
CAPACITY - 4000^W @ 24" LOAD CENTER

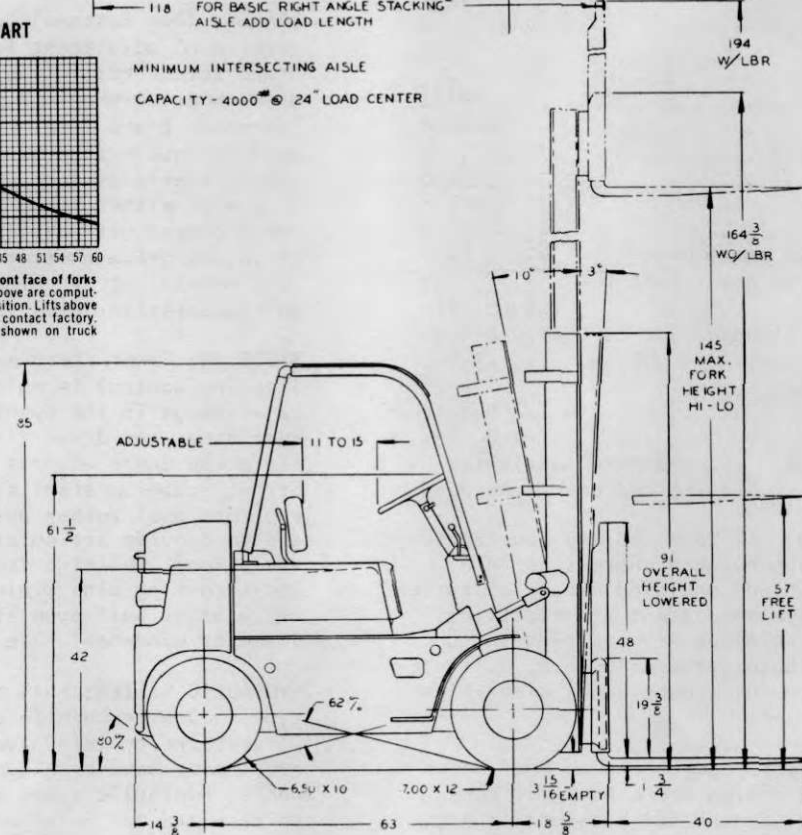



INDUSTRIAL TRUCK DIVISION



OPERATORS
 MAINTENANCE
 PARTS
 MANUAL
 FOR
 CY-60

CLARK EQUIPMENT COMPANY

TECHNICAL OFFICE DEPARTMENT
 BATTLE CREEK, MICHIGAN U.S.A.
 FURNISHED BY



INDUSTRIAL TRUCK DIVISION



OPERATORS
 MAINTENANCE
 PARTS
 MANUAL
 FOR
 CY-60

CLARK EQUIPMENT COMPANY

TECHNICAL OFFICE DEPARTMENT
 BATTLE CREEK, MICHIGAN U.S.A.
 PUBLISHED BY

LIFT AND TILT CYLINDERS

Check for drift, leakage at packings, damage and security of mountings. (Anchor pivot pins, flanges and mounting rings).

LIFT CHAINS

The lift chains are mounted to the chain anchors on the lift carriage and at the chain anchor rods near the lift cylinder piston head.

If it becomes necessary to adjust the lift chains, proceed as follows:

x x	
x	x
x	W A R N I N G
x	x
x	KEEP CLEAR OF LOAD AND CARRIAGE WHEN
x	x
x	MAKING ADJUSTMENTS TO AVOID INJURY IF
x	x
x	ANY MALFUNCTION SHOULD OCCUR AND CAUSE
x	x
x	LOAD OR CARRIAGE TO FALL.
x x	

1. Elevate carriage to about 4 feet.
2. Smear grease on the innerslide channel as shown in Plate 8622.
3. Pick up a capacity load.

N O T E

It is important that the chain adjustment be made with a capacity load. In this manner you will allow for chain stretch.

4. Making sure uprights are either vertical or aft of vertical, lower load to the bottom.
5. Remove capacity load.
6. Raise carriage and measure the distance from where the center of the bottom carriage roller stopped, to the bottom edge of the inner slide. Distance must not be less than $\frac{1}{2}$ ".

LUBRICATE MACHINE

Lubricate all miscellaneous linkage with SAE 20 oil and all grease fittings with chassis grease. (Refer to Lubrication Chart).

C A U T I O N

WHEN LUBRICATING MACHINE, INSPECT FOR LEAKING HYDRAULIC LINES, FITTINGS, AND DAMAGED ELECTRICAL WIRING.

HYDRAULIC CONTROL VALVE AND LINES

Inspection for damage, leakage and security of mounting.

LIFT BRACKET

Inspect for damage, bent forks, etc.

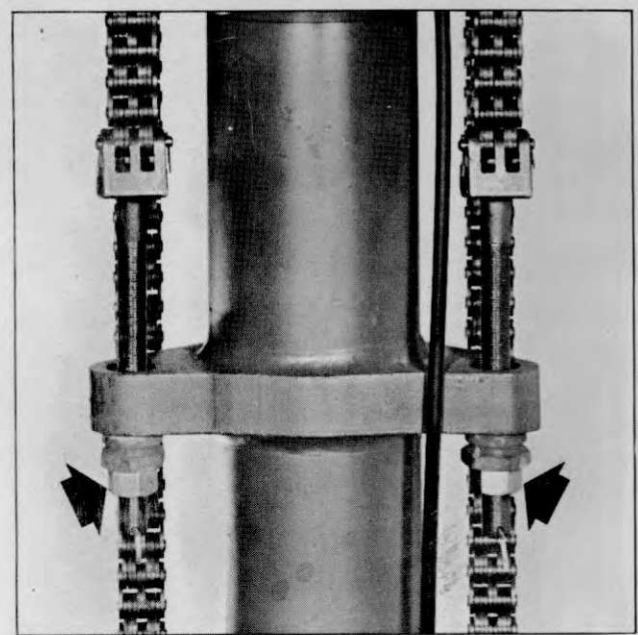

Plate 6634. Lift Chain Adjustment (Chain Anchor Rods)

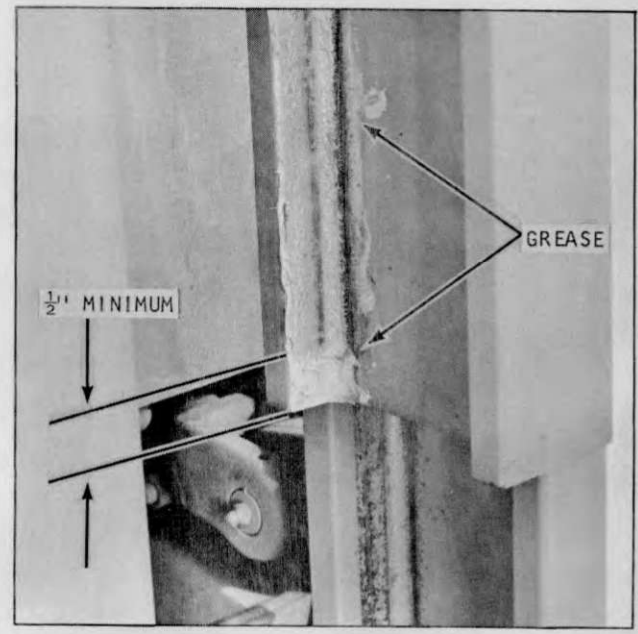

Plate 8622. Lift Chain Adjustment

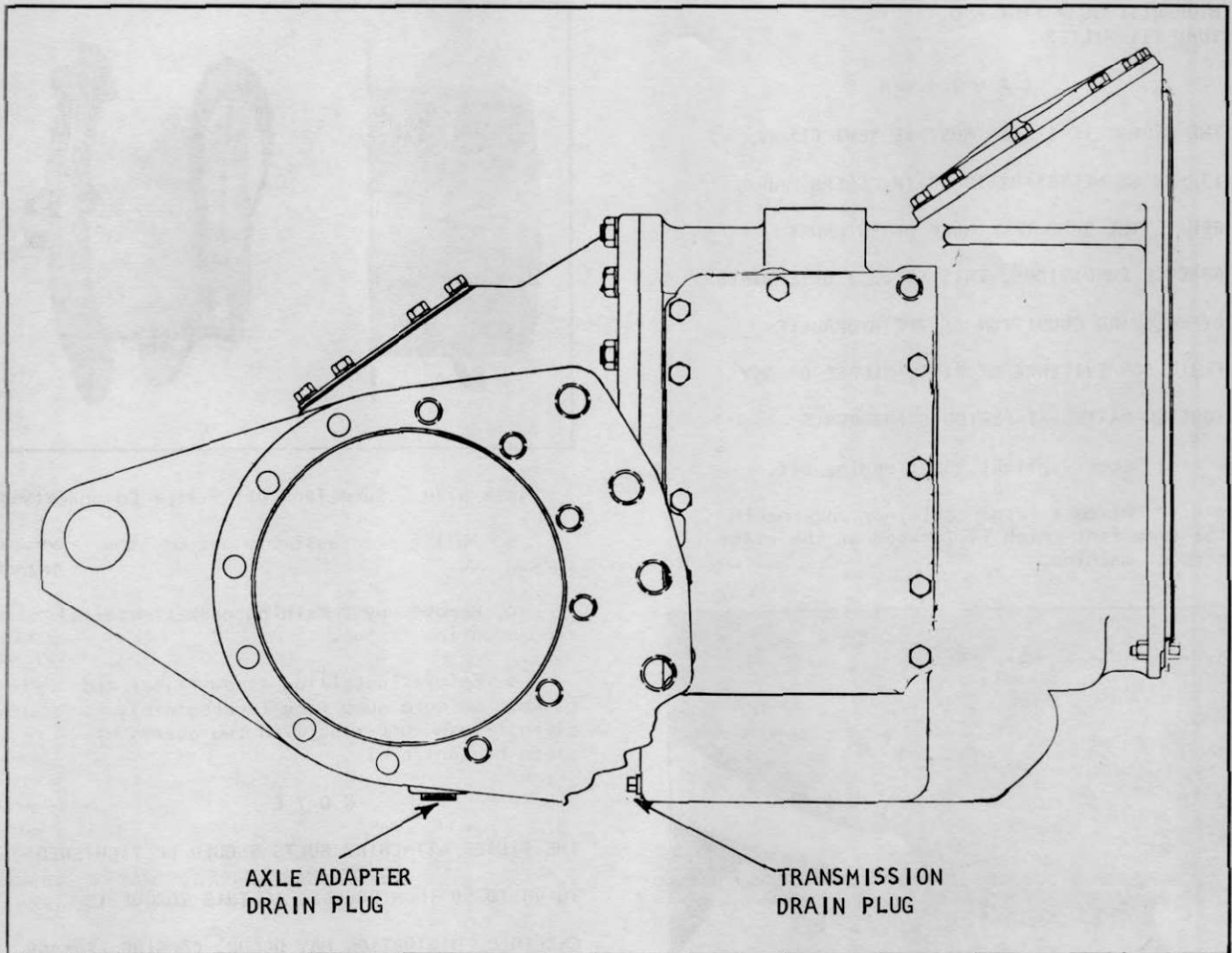

Plate 7301. Axle Adapter and Transmission Drain Plugs

have self-locking adjusting screws that require no lock nuts.

g. If 0.015 inch feeler moves freely when valve is not being lifted, the clearance is too great. Hold valve lifter with an open end wrench while using a second wrench to turn valve lifter adjusting screw counterclockwise 1/4 to 1/2 turn. Repeat clearance check and adjustment until proper clearance is obtained.

h. Repeat clearance check and adjustment on remaining intake valves.

i. With engine running at idling speed and at normal operating temperature, adjust exhaust valve as follows:

j. Check for proper 0.014 inch clearance by alternately passing a 0.013 inch and a 0.015 inch flat feeler gauge between head of adjusting screw and valve stem cap, See Plate 3223.

k. Follow procedure outlined in paragraphs (d) thru (h).

m. Install valve chamber cover using new valve chamber cover gasket and replace cover mounting screws.

N O T E

DO NOT REUSE OLD GASKETS. THEY DO NOT

AFFORD A POSITIVE SEAL.

n. Check valve chamber cover gasket for leaks.

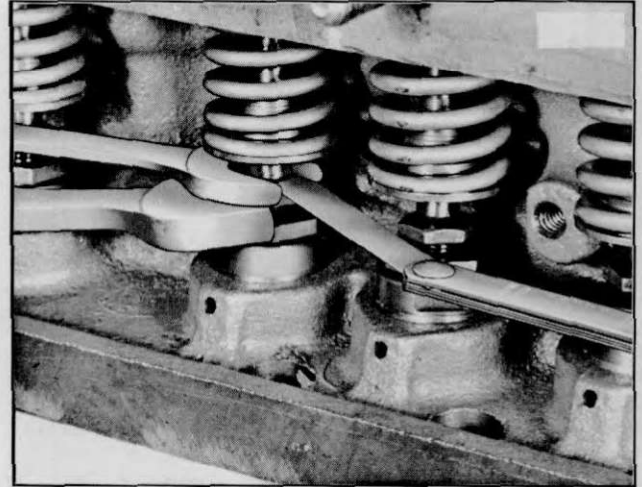

Plate 3223. Adjusting Valve Clearance

6A. COLD SETTING. (ALTERNATE METHOD)

To adjust valve clearance when engine is at room temperature and not running, proceed in the following manner:

a. Remove distributor cap.

b. Crank engine until distributor rotor points to No. 1 cylinder position with the breaker points open. In this position the No. 1 piston is at the top of its compression stroke with both lifters on the base circle of the cam and both valves can be adjusted.

c. Adjust the valve clearance to 0.012 inch on the intake and 0.020 inch on the exhaust. The exhaust (e) and intake (I) valve arrangement on the six cylinder engine is: E-I-I-E-E-I-I-E-E-I-I-E.

d. The other valves may be adjusted by setting the engine with the distributor rotor pointing to the rest of the cylinder positions in the sequence of the firing order which is 1-5-3-6-2-4.

CLICK HERE TO **DOWNLOAD** THE COMPLETE MANUAL

- Thank you very much for reading the preview of the manual.
- You can download the complete manual from: www.heydownloads.com by clicking the link below



- Please note: If there is no response to CLICKING the link, please download this PDF first and then click on it.

CLICK HERE TO **DOWNLOAD** THE COMPLETE MANUAL

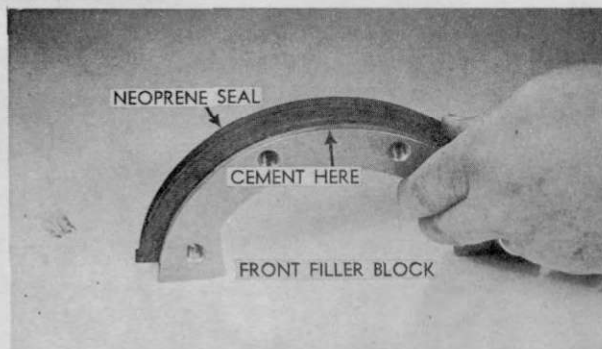

Figure 65 — Installing Neoprene Seal in Front Filler Block

2. Neoprene seal on front filler block is installed in the same manner.

When replacing gear cover, cement gasket to gear cover with a quick drying gasket cement and reassemble to engine block.

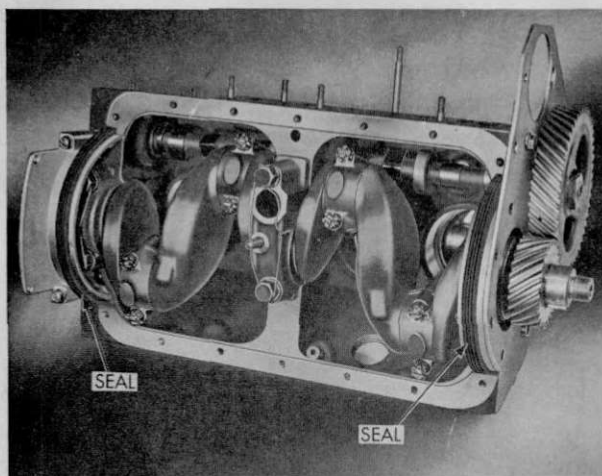

Figure 66 — Neoprene Seals in Place

HYDRATORK DRIVE

Model HI25

Description

The hydratork drive unit is composed of an automotive type torque converter and hydraulically actuated direction selectors geared to the transmission and differential.

In order to service the hydratork drive unit, it is important to first understand how it operates. The construction and operation of the torque converter is discussed under the heading "Torque Converter". To understand the basic operation of the hydratork drive unit, two diagrams are shown to illustrate how the hydratork works.

The necessary maintenance and servicing procedures of the transmission including removal, disassembly, inspection, reassembly and installation of the transmission are discussed in the Transmission Section on Pages 06M202G through 06M202Y.

Torque Converter

The torque converter is composed of three members: the impeller or driving member, the turbine or driven side and the stator or reaction member. The impeller or driving side forms the outer shell of the converter and the turbine and stator operate within the shell but turn free of the impeller. The impeller or outer shell is bolted directly to the flywheel and turns at engine speed.

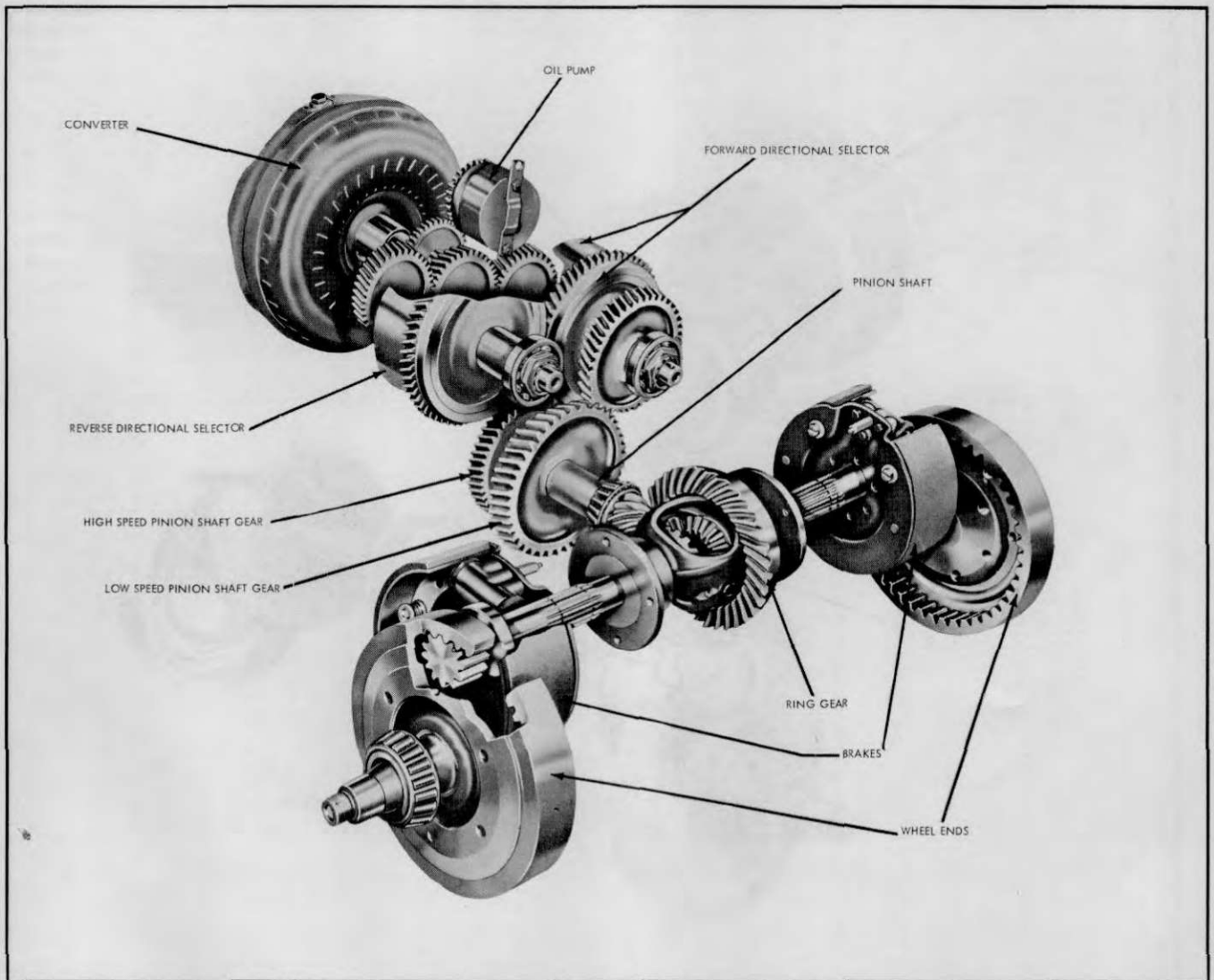

Plate 5983. Transmission and Wheel Ends

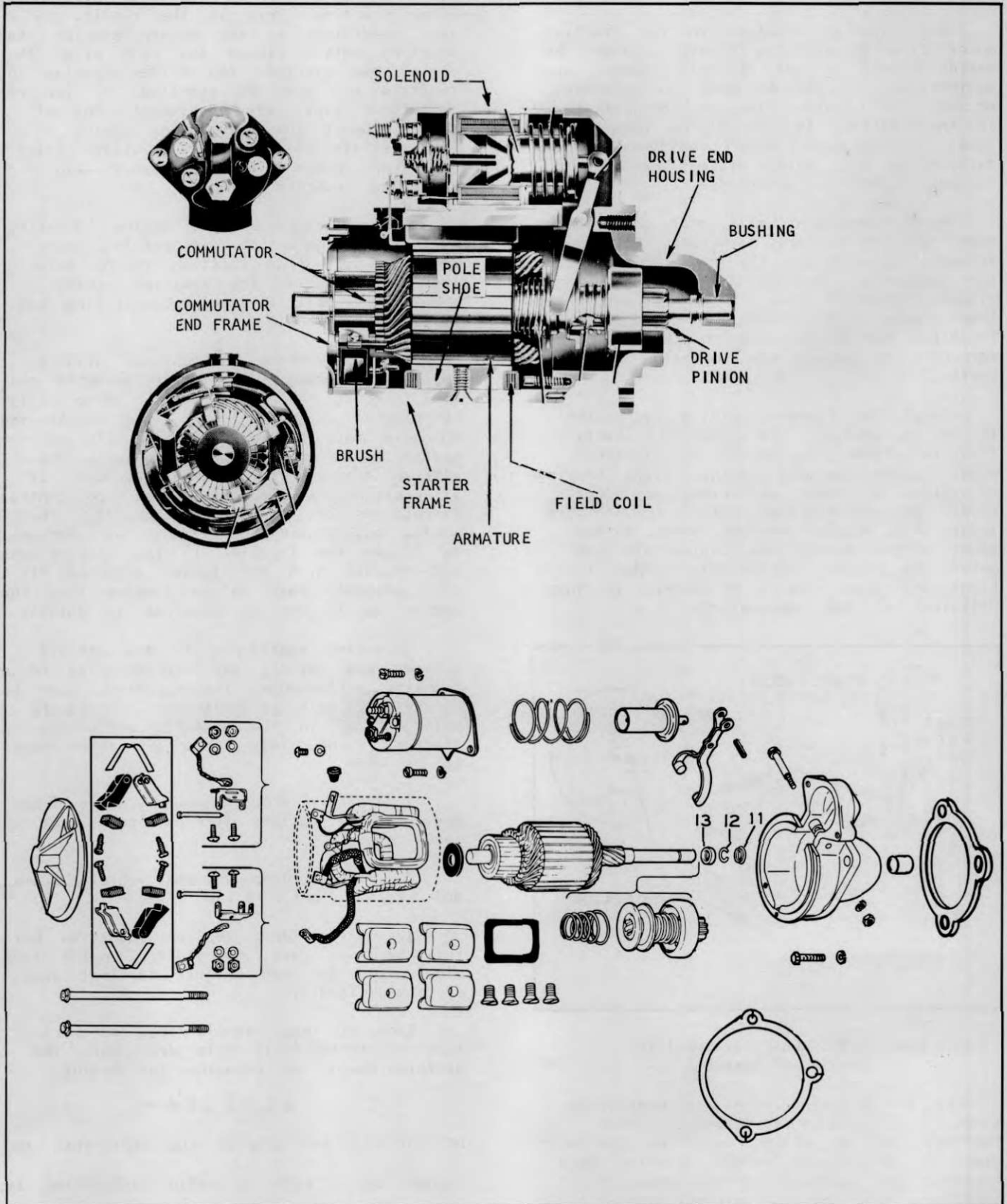

Plate 6997. Starter

CLICK HERE TO **DOWNLOAD** THE COMPLETE MANUAL

- Thank you very much for reading the preview of the manual.
- You can download the complete manual from: www.heydownloads.com by clicking the link below



- Please note: If there is no response to CLICKING the link, please download this PDF first and then click on it.

CLICK HERE TO **DOWNLOAD** THE COMPLETE MANUAL