

CLAAS



ROLLANT 240
ROLLANT 250 / 250 ROTO CUT
ROLLANT 254 ROTO CUT
ROLLANT 255 ROTO CUT

Operator's manual

SERVICE & PARTS

CLICK HERE TO **DOWNLOAD** THE COMPLETE MANUAL

- Thank you very much for reading the preview of the manual.
- You can download the complete manual from: www.heydownloads.com by clicking the link below



- Please note: If there is no response to CLICKING the link, please download this PDF first and then click on it.

CLICK HERE TO **DOWNLOAD** THE COMPLETE MANUAL

Special counter	10.4.3	Setting the language	11.5.7
Start special counter	10.4.3	Aux. menu	11.5.8
Correct bale count	10.4.4	Pre-settings	11.6.1
Reset job	10.4.4	Pick-up function	11.6.1
Fault display	10.5.1	Pick-up	11.6.1
Error display in text mode	10.5.1	Activate cutting unit	11.6.2
Switch off warning signal	10.5.2	Checking the position of the cutting unit	11.6.3
Delete fault	10.5.2	Standard machines:	11.6.3
Application example	10.6.1	Cutting unit active	11.6.3
		Cutting unit deactivated	11.6.3
		Recharging the cylinder pressure starting with the first bale	11.6.4
		Process for activating the function starting with the first bale	11.6.4
		Turn rotor back	11.6.5
		Baling and wrapping	11.6.6
		Automatic twine wrapping	11.6.6
		Automatic net wrapping	11.6.7
		Manual wrapping - twine wrapping and net wrapping ...	11.6.8
		Bale output	11.6.9
		Automatic opening of tailgate	11.6.9
		Opening the tailgate manually	11.6.9
		Fault in the bale chute	11.6.10
		States of the baler	11.6.11
		Twine wrapping without recharging the pressure	11.6.11
		Net wrapping without recharging the pressure	11.6.13
11. CLAAS COMMUNICATOR		12. Faults and remedies	
Overview – CLAAS COMMUNICATOR		Faults, Cause or remedy	12.1.1
(ROLLANT 254/255 optional)	11.1.1	Twine wrapping	12.1.1
Switching on the Claas Communicator	11.1.2	Net wrapping	12.1.2
Overview – Claas Communicator	11.1.3		
Incremental encoder and keys	11.1.4	13. After use	
Incremental encoder	11.1.4	Unhitching the baler	13.1.1
Softkeys	11.1.4	Wheel chocks	13.1.1
Navigational keys for the menu	11.1.4	Parking support	13.1.1
Main menu	11.1.5	Control box	13.1.2
Application menu	11.1.6	Standard operation	13.1.2
Work functions	11.1.6	Control panel (ROLLANT 254/255 optional)	13.1.2
Information window in the application menu	11.1.7	Claas Communicator (ROLLANT 254/255 optional)	13.1.3
Setup menu	11.1.7	Removing the hydraulic hoses and cables	13.1.3
Functions in the settings menu	11.1.7	Propshaft	13.1.3
Functions with set parameters	11.1.7	Castor gauge wheels (ROLLANT 250/254/255)	13.1.4
Counter menu	11.1.8		
Main menu	11.1.8	14. Maintenance	
Display window current job	11.1.8	Important notes on maintenance	14.1.1
Fault menu	11.1.9	General notes on maintenance	14.1.1
System information menu	11.1.9	Maintenance and lubricant charts	14.2.1
Operator settings	11.2.1	Maintenance table	14.2.1
Select type of wrapping	11.2.1	Lubricants table	14.2.2
Setting the number of net windings	11.2.2	Drive system	14.3.1
Setting the twine length	11.2.2	Shearing bolt on main drive (optional for ROLLANT 240/250/254)	14.3.1
Setting the delay between end of baling and start of net wrapping	11.2.3	Shear bolt pick-up drive	14.3.1
Setting the automatic opening of the tailgate	11.2.4	Angle drive gearbox	14.3.2
Setting the recharging of the baling pressure in the hydraulic cylinder	11.2.5	Adjusting the tension of the drive chains	14.3.3
Knife cleaning sequence	11.2.6	Tensioning the pick-up drive chain	14.3.4
Settings in the counter menu	11.3.1	Adjusting the chain tensioner	14.3.4
Selecting job orders	11.3.1		
Resetting the work record counter	11.3.1		
Resetting the daily counter	11.3.2		
Resetting the service display	11.3.2		
Fault display	11.4.1		
Main menu »Service«	11.5.1		
Opening the service menu	11.5.1		
System information menu	11.5.2		
Image adjustment menu	11.5.3		
Setting the contrast	11.5.3		
Setting the brightness	11.5.3		
Time and date menu	11.5.4		
Setting the time or date	11.5.4		
Memory management menu	11.5.5		
Administration of the saved projects	11.5.5		
Reduce conflicts between the baler and the tractor	11.5.6		
Language selection menu	11.5.7		

4

Concerning safety



4

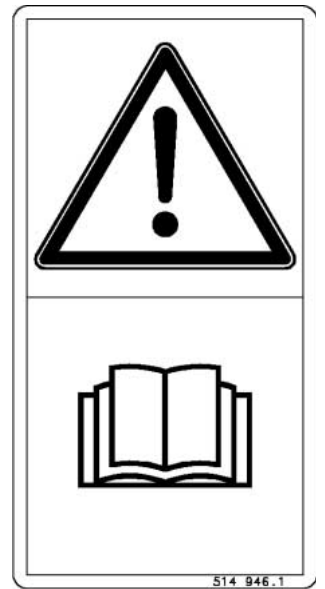

5

514 946.1 (2)

Before putting the machine into operation, read and observe the operator's manual and follow the safety instructions.

(Fig. 4, 5)



30

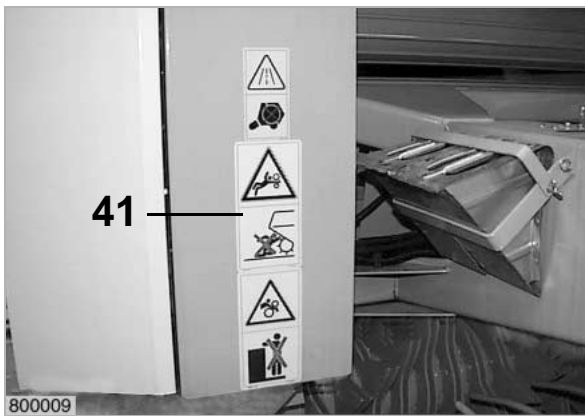

31



32

516 055.0 (41)

Keep hands away from hazard area of pickup as long as the tractor engine is running.

(Fig. 30, 31, 32)

CLAAS ROLLANT 240/250/ROLLANT 250/254/255 RC

Wheels

Tyres	Air pressure
11.5/80 - 15.3 8 PR	2.0 bar (for Rollant 240/250)
15.0/55 - 17 10 PR	2.0 bar (for Rollant 240/250/254/255)
19.0/45 - 17 10 PR	2.0 bar (for Rollant 240/250/254/255)
500/45 - 22.5 8 PR	1.7 bar (for Rollant 254/255)

Tightening torque for lug nuts 296 Nm

Hydraulic system

- 2 double-acting hydraulic cylinders for tailgate
- 1 single-acting hydraulic cylinder for pick-up lift mechanism
- 2 single-acting hydraulic cylinders for cutting mechanism
- 1 double-acting hydraulic cylinder for hydraulic rotor reverse

For CLAAS Control-Terminal (CCT) models or hydraulic rotor reverse

Tractor hydraulics required

Standard balers	<ul style="list-style-type: none"> 1 double-acting control valve with auxiliary hydraulic outlets is required for the tailgate latches 1 single-acting control valve with auxiliary hydraulic outlet is required for the hydraulic pick-up lift mechanism or for engaging / disengaging the knives 1 double-acting control valve for hydraulic reversing of rotor (option)
CCT balers	<ul style="list-style-type: none"> 1 single-acting control valve with auxiliary hydraulic outlet 1 quick-release coupling socke 3/4" so oil returns to the hydraulic tank without pressure (included in delivery)

Flow rate of hydraulic oil

Standard	Maximum 80 litres / minute
For CCT model	Maximum 80 litres / minute
Hydraulic pressure for Tractor	Maximum 230 bar, Minimum 130 bar
Maximum oil temperature	80 °C

Electrical systems

Tractor electrical systems required 7-pin socket for lighting equipment
2-pin appliance socket (12 Volt) with 25 A in-line fuse
10.5 - 16.5 V

Weights

Basic machine	
with twine and net wrapping	2680 kg
with gauge wheels for pick-up	+ 40 kg
Permissible maximum weight for CCT model	2970 kg

7

Before starting operation

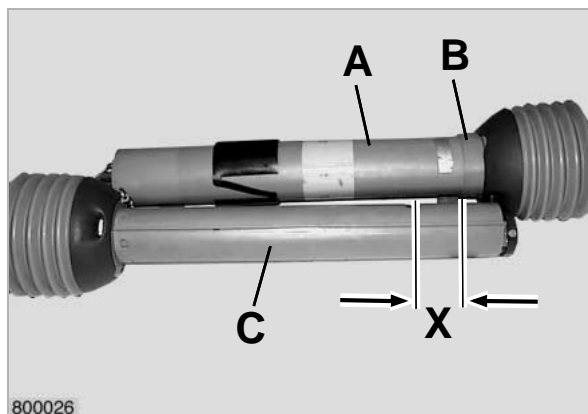

800026

18

Shortening the propeller shaft

Maintain the two halves of the propeller shaft against one another at the shortest operating setting.

Mark out a dimension of 40 mm (X) from the edge (B) of the outer protective tube (A) on the inner protective tube (C).

(Fig. 18)

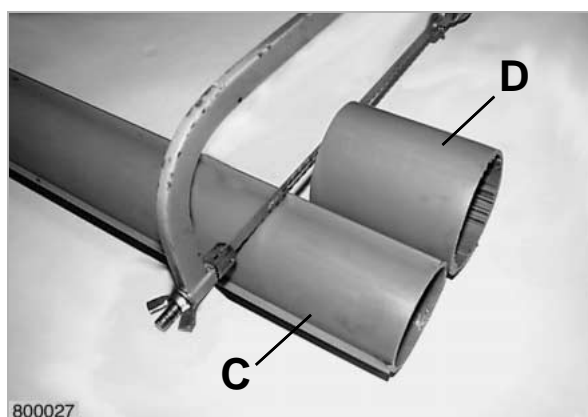

800027

19

Dismantle the protective tubes.

Cut the outer protective tube (A) at the marked spot.

Hold the cut section (D) against the inner protective tube (C) and cut off the same length on the inner protective tube.

(Fig. 19)

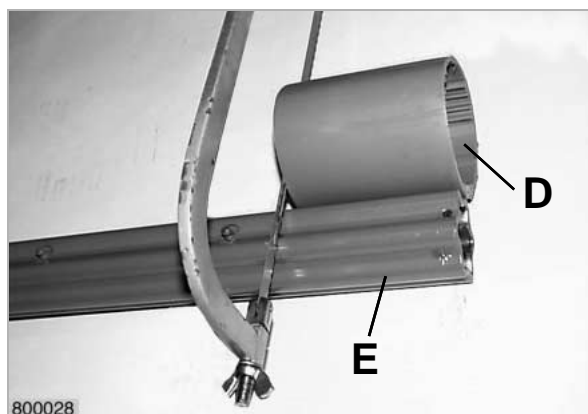

800028

20

Shorten the outer profile tube (E) and the inner profile tube (F) by the same length as the cut off section (D) from the outer protective tube (the inner profile tube is hardened).

Smooth the cut edges (deburr) and carefully remove the swarf.

Grease the propeller shaft once pushed together.



Attention!

Insufficient grease on the profile tube will reduce the service life of the propeller shaft.

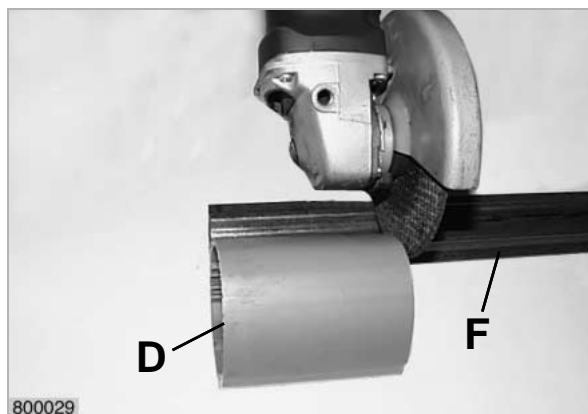

800029

21

(Fig. 20, 21)

BEFORE TRANSPORTING THE BALER

1. Hook the round baler to the tractor, secure the hitch pin.
2. Raise the jack stand.
3. Connect the universal drive shaft and the hydraulic hoses.
4. Connect the power supply cable.
5. Raise the pick-up to the maximum height and lock it into position.
6. Place the wheel chocks into the holders provided.
7. Pull off the springs on the roller crop guard (option).

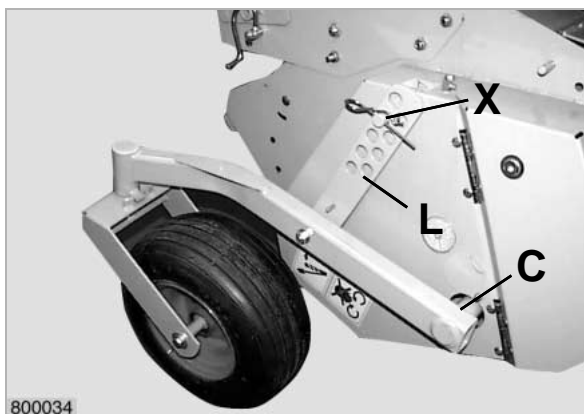
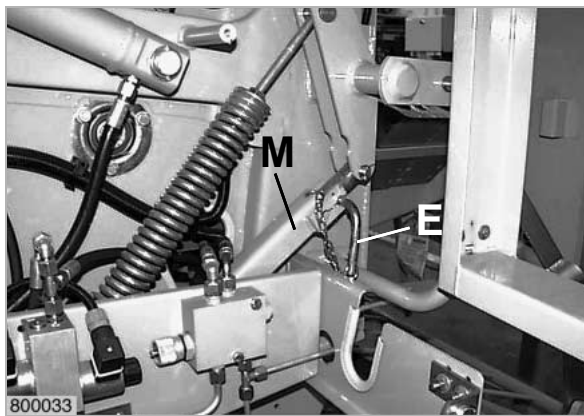

PICK-UP

Pick-up, transport and work positions

The working height can be adjusted via the hydraulic cylinder (M) and the telescopic tube, and by relocating pin (E).

Raise the pick-up completely for transport.

When used with the standard operation, the pick-up lowering depth on hydraulic cylinder (M) is set using plug (E).

- 1 During operations, it is essential that the tractor control unit is locked in its float position since otherwise the pick-up and/or gauge wheels of the hydraulics may be damaged by the impact produced (uneven ground).

Adjusting the working height of the pick-up (pick-up without gauge wheels)

Lower the pick-up until the tines clear the ground by 20 to 30 mm. Lock the telescoping tube on the hydraulic cylinder (M) with pin (E) accordingly.

(Fig. 1)

- 2 **Adjusting the working height of the pick-up
(pick-up with gauge wheels)**

Use in hay and silage:

Lower the pick-up until the gauge wheels rest on the ground.

Lock the telescopic tube on the hydraulic cylinder (M) with pin (E) so that the pick-up can move up and down freely.

The tines should clear the ground by some 20 to 30 mm. If required, adjust the gauge wheels (X) accordingly. Make sure to adjust both gauge wheels equally.

(Fig. 1, 2)

Use in hay and straw:

Lower the pick-up completely. Afterwards raise it by hand until the tines are at the height of the stubble.

If possible, adjust the height of the gauge wheels so that they do not touch the stubble.

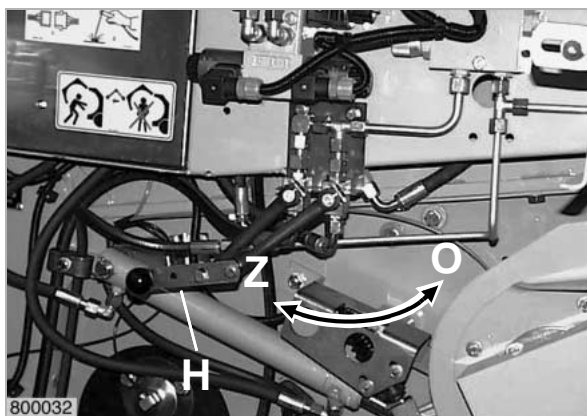

800032

23

Safety lock for the tailgate



Danger!

When working with an open tailgate or in the baling chamber, move the lever (H) of the safety lock all the way to position (Z).

Before closing the tailgate, move lever (H) all the way to position (O).



Note!

Illustration (23) shows the safety barrier on ROLLANT 240 and ROLLANT 250.
Illustration (24) shows the safety barrier on ROLLANT 254/255.

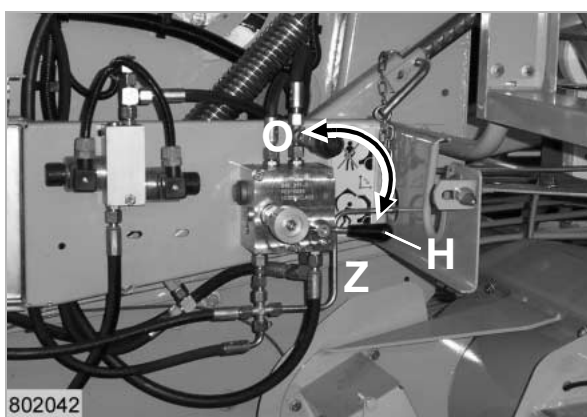

802042

24

(Fig. 23, 24)



800043

25

Ladder

(for baling with net wrapping)

To climb on the baler fold the ladder (A) down.



Danger!

Only climb on the round baler when the tractor engine is switched off and the ignition key has been removed.

Fold the ladder back up before using the baler.

(Fig. 25)

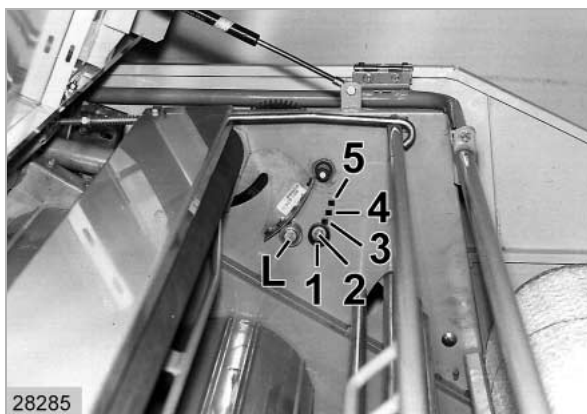

16

Setting the number of net wraps

ROLLANT 240/250/254/255 with standard controls:

The number of net wraps can be selected by adjusting the the eccentric end stop (L). The actual setting of the end stop (L) depends on the condition of the crop. Under normal harvesting conditions 2.2 wraps will be sufficient. For exceptionally dry or brittle crops or if the bales are to be exposed to extra strain due to outdoor storage or transport, set the limit stop (L) further down.

(Fig. 16, 17)

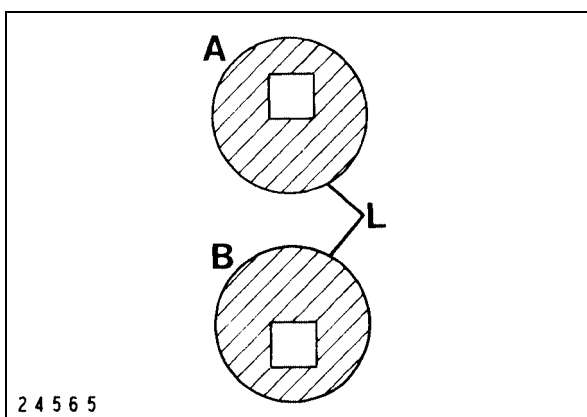

17

ROLLANT 254/255 with CCT:

All adjustments are made with the Control-Terminal/ Claas Communicator. The end stop (L) is always in hole (5) and in position (B).



Note!

If the adjustment and position of (L) are changed, the number of net wraps (Control-Terminal/Claas Communicator) does not correspond to the actual number of wraps.

(Fig. 16, 17)

Hole	Stop position	Number of wraps
1	A	4.1
	B	3.8
2	A	3.5
	B	3.2
3	A	2.9
	B	2.5
4	A	2.2
	B	1.9
5	A	1.6
	B	1.3

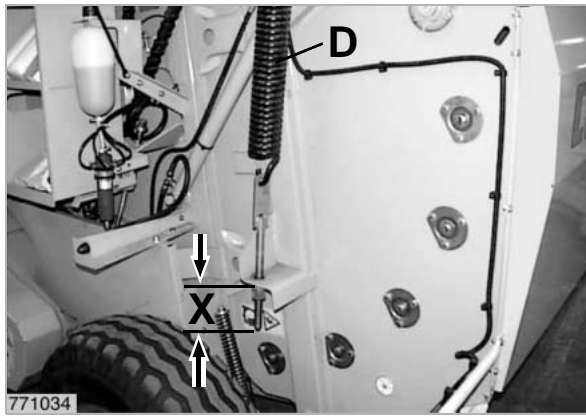
**5**

Tension the tension springs (D) for the swinging section to dimension (X) 75 mm. Secure the nut with a locking nut.

Attach the protective panels.

(Fig. 5)

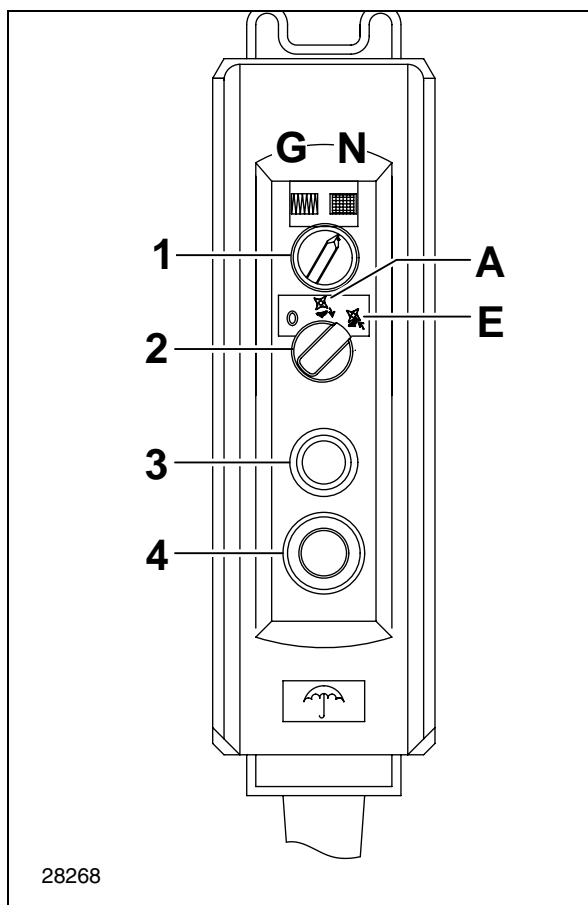

Delay time for automatic net wrapping

The delay time is the time between completing the bale and the start of the automatic net wrapping sequence. This time allows the operator to bring the tractor and the baler to a complete stop.

Automatic net wrapping begins when:

- the light in the pushbutton switch (3) on the control box goes on,
- there is an acoustic warning tone.

The delay time to stop the tractor is set from the factory to a default time of 4 seconds. Once this time has passed, the rotating bale will take up the net.

Checking the delay time

Switch on the control box, to do this, switch the rotary switch (2) to position (A) or (E).

- 0 = Power supply switched off,
- E = Knives in cutting chamber,
- A = Knives out of cutting chamber.



Note!

Only operate the rotary switch (2) when the baler is stationary.

8

When the system is operational, then the control lamp in rotary switch (1) is illuminated.

Should the control lamp in the rotary switch (1) flash repeatedly, then the baler's automatic net wrapping system is not operational. Should this be the case, then possible reasons are listed in the operator's book under section 9.1.1.

(Fig. 8)

CLICK HERE TO **DOWNLOAD** THE COMPLETE MANUAL

- Thank you very much for reading the preview of the manual.
- You can download the complete manual from: www.heydownloads.com by clicking the link below



- Please note: If there is no response to CLICKING the link, please download this PDF first and then click on it.

CLICK HERE TO **DOWNLOAD** THE COMPLETE MANUAL

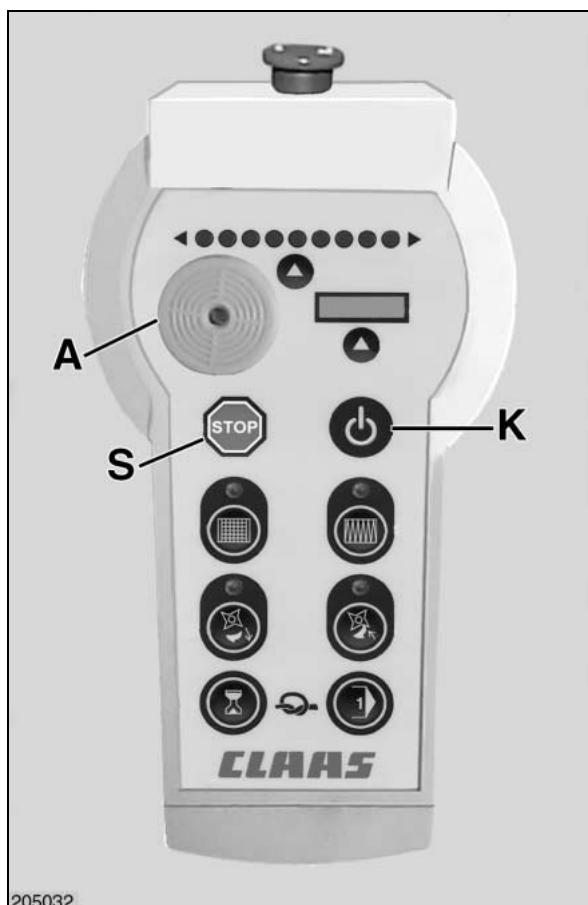

10

Automatic wrapping

i Note!

If control light (K) lights up or flashes quickly after starting operation of the round baler, the round baler is not ready for automatic wrapping.

Before binding correct the causes.

Possible causes:

- the tailgate is open,
- the ramp is pressed down,
- the twine binding levers are not in the home position.

Binding and ejecting bales

Once the bales have reached the set compression, the binding procedure automatically begins.

The stop symbol (S) lights up and the signal generator (A) emits a sound. The error message control lamp (K) flashes.

The tractor must now be stopped within the delay period until binding starts.

The binding twine or the net is then caught up by the rotating bale and drawn in.

i Note!

The delay time is the time period between completion of the bale and the start of automatic wrapping.

As soon as the binding process has finished the stop symbol light (S) goes out.

For twine binding, the end of the binding procedure is also notified by the fact that the twine guide lever has stopped.

For net binding, the end of the binding process can also be detected by the fact that the movement of roll of netting ceases and the blade can be heard as it cuts off the net.

(Fig. 10)

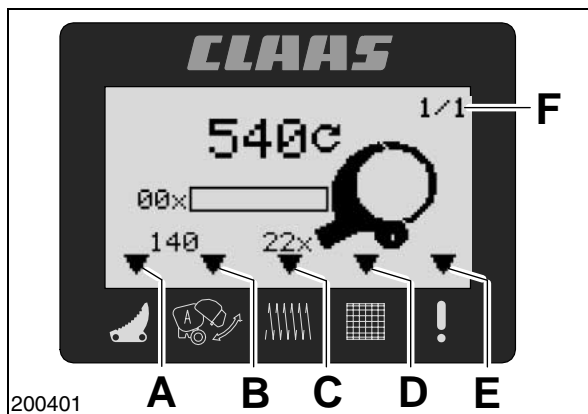

200401

2

Status display

- A** = Knives on / off
The display lights up when the knives are on.
- B** = Automatic tailgate operation
The display lights up when automatic tailgate operation is activated.
With automatic tailgate operation, the tailgate opens automatically when the wrapping cycle is complete.
- C** = Twine wrapping
The display lights up when twine wrapping is activated.
- D** = Net wrapping
The display lights up when net wrapping is activated.
- E** = Fault message
The display lights up when there is a fault.
- F** = Menu and operational status indicator
When the symbol (F) blinks, the connection between the control terminal and the baler is working.

(Fig. 2)

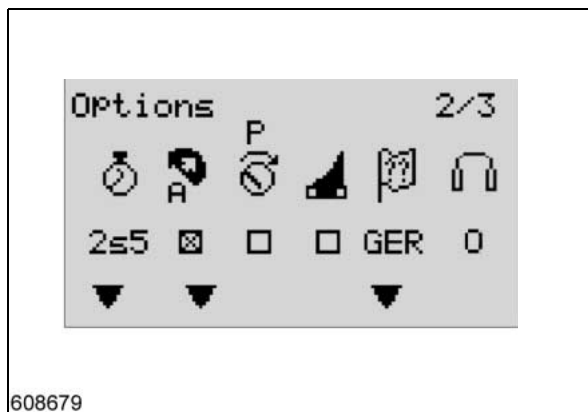

608679

3

The display (F) can have the following values:

Main menu	Submenu	Display F
Job data	Drive speed	1/1
	Wrapping sequence	1/2
Settings	Net wrapping	2/1
	Twine wrapping	2/2
	User settings	2/3
Counter	Daily / overall counter	3/1
	Special counter	3/2
Fault display	Fault symbols kein or no fault	4/1

Example: If the menu »User settings« is open, the menu display »2/3« appears.

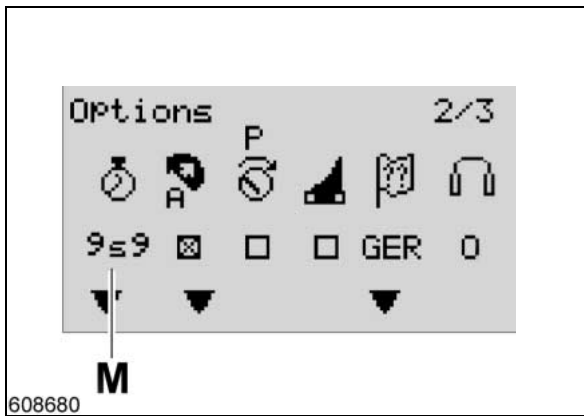
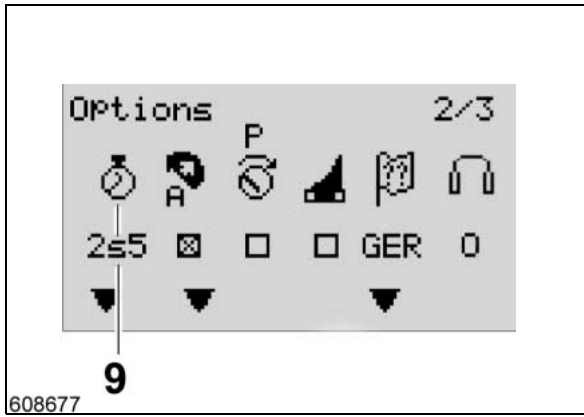

(Fig. 3)



Setting the delay time until the start of automatic or manual wrapping

If the time between the warning signal for a full baling chamber and the start of the automatic wrapping is not long enough to stop the baler, the start of the automatic wrapping operation can be delayed between 1 and 9.5 seconds:

Call up the »User settings« submenu.

- 4  Press the submenu key as many times as needed until the function »Set delay time« is active and symbol (9) blinks.
-  Increase the delay time in steps of 0.5 second with this key. If the 9.5 seconds are exceeded, the display shows «9s9» (M). Manual net wrapping is activated.
-  Decrease the delay time in steps of 0.5 second with this key. To reactivate automatic net wrapping, choose a time between 1 and 9.5 seconds with the key (-).

5 (Fig. 4, 5)

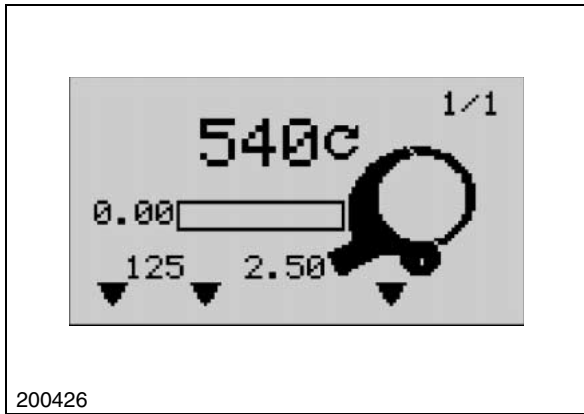

1

APPLICATION EXAMPLE

The following example shows the display during an automatic wrapping cycle (automatic tailgate operation is activated):

1. Baler is working.

(Fig. 1)

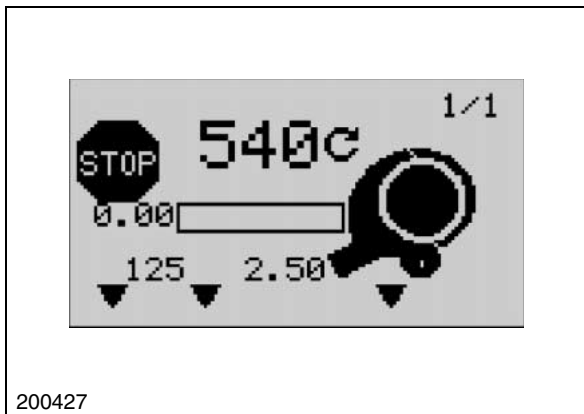

2

2. Stop baler!

A beep indicates when the wrapping cycle starts.

(Fig. 2)

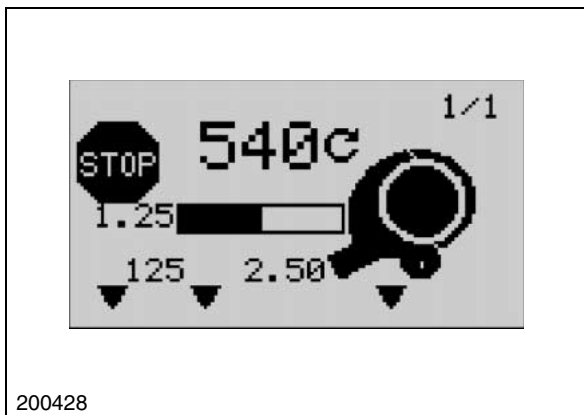

3

3. Wrapping cycle in progress.

(Fig. 3)

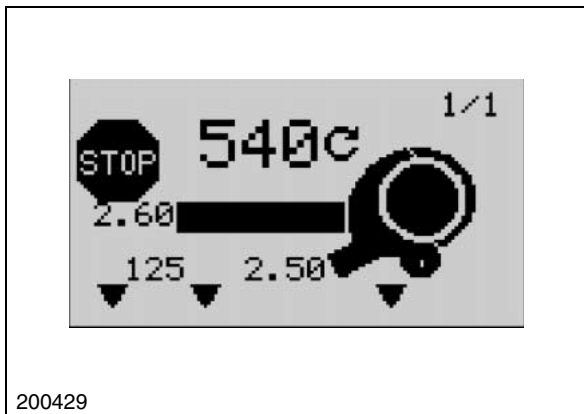

4

4. The length of net / twine selected has been reached, knife is activated.

(Fig. 4)



9

Information window in the application menu

1. Number of the current job
2. Total number of bales for the current job
3. Daily bale counter
4. Progress of bale wrapping
5. Status of wrapper (not used with this baler)
6. Symbolic display of the activated functions (automatic tailgate, reloading the baling pressure, etc.)
7. Status of baler
8. PTO speed
9. Selected length (twine or net)
10. Display of wrapping progress
11. Symbol of current type of wrapping

(Fig. 9)

Setup menu



The baler can be set to various operating modes in the »Settings« menu.

Functions in the settings menu

1. Fault deletion
2. Wrapping selection: Twine or Net
3. To the previous menu (»Application Menu«)
4. To the next menu (»Counter menu«)



10

Functions with set parameters

1. Number of net wrapping revolutions
2. Number of twine wrapping revolutions
3. Setting the delay between end of baling and start of net wrapping
4. Automatic opening of tailgate
5. Recharging the baling pressure in the hydraulic cylinder
6. Knife cleaning sequence
7. Symbol for type of wrapping pre-selected

(Fig. 10)

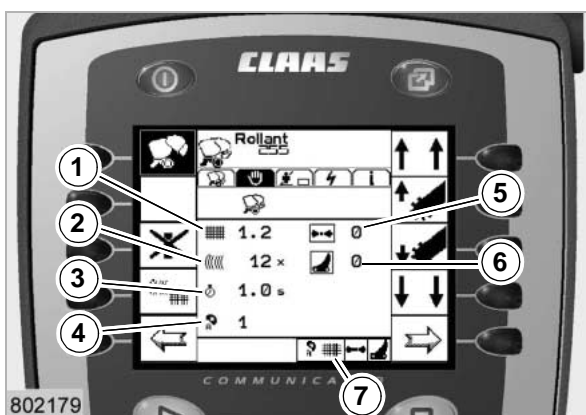

11



9

SETTINGS IN THE COUNTER MENU

Selecting job orders

The CLAAS COMMUNICATOR can manage 20 jobs simultaneously.

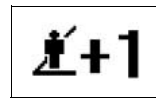

To jump to the next job, press key (H).



To jump to the previous job, press key (K).

(Fig. 9)



10

Resetting the work record counter

The data concerning the jobs is displayed in window (L). These data can be reset with key (J).

Select the order to be reset as described above, for example order 1.



By pressing key (J), all values in window (L) are reset.

Only the job number is not reset.

(Fig. 9, 10)

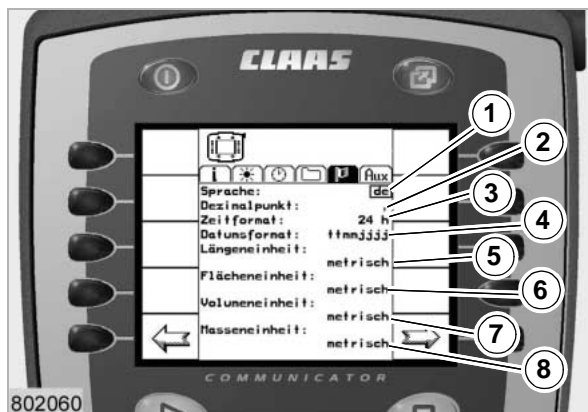

9

Language selection menu

Setting the language

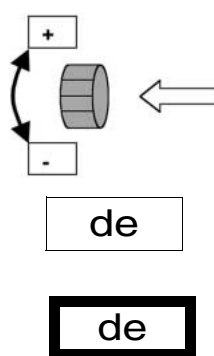

Turn the incremental encoder until the value that has to be changed, e.g. the language, appears surrounded by a frame.

Press the incremental encoder to change the language. The frame appears enlarged. Turn the incremental encoder to change

the language.

Press the incremental encoder to confirm.

Switch the Class Communicator off and on again to activate the newly selected language.

Making a different selection:

Adjust decimal dot (2), time format (3), date format (4), length unit (5), area unit (6), volume unit (7) and mass unit (8) in the same way.

The following options may be selected:

- Language (1): de ; en ; fr ; nl ; da ; sv ; cs ; fi ; ru ; tr

i Note!

The languages used in the Claas Communicator are German, English and French. The other languages are not yet available with the Claas Communicator, although the languages are shown in the language selection menu.

- Decimal dot (2): , or .
- Time format (3): 12h or 24 h
- Date format (4): ttmjyyy - ttjjjmm - mmjjjtt - mmtjjj - jjjmmtt - jjjttmm
- Length unit (5): metric or imperial
- Area unit (6): metric or imperial
- Volume unit (7): metric or imperial or US
- Mass unit (8): metric or imperial or tons/pounds

(Fig. 9)



9

Bale output



Attention!

On slopes place the bales so that they cannot roll away.

Automatic opening of tailgate

The »automatic opening of the tailgate« can be selected in the adjustment menu.

After the bale is finished, the tailgate opens automatically to enable the bale output. The tailgate also closes automatically again.



Observe!

It is always possible to override the opening of the tailgate manually. To this end, just activate key (S). This does not delete the function »Automatic opening of tailgate« from the memory of the CLAAS COMMUNICATOR.



Observe!

Closing the tailgate is not possible when a bale is blocked on the bale chute, i.e. when the output ramp is in the bottom position.

(Fig. 9)

Opening the tailgate manually

If the function »automatic opening of tailgate« is not activated, the tailgate must be opened manually.

Procedure:

Bale wrapping is finished, the symbol »Stop« is displayed: the bale has to be discharged.



Press key (S) once to open the tailgate completely.

Press key (S) and keep it pressed to control the opening of the tailgate.

(Fig. 9)

Faults	Cause or remedy
Netting breaks at the start of wrapping.	<ol style="list-style-type: none"> 1. Tension too high on net tensioner. Loosen the net tensioner or re-feed the netting through a one guide (brake) roller arrangement only. 2. The net brake shackle is dirty and needs cleaning. 3. The V-belt brake is not engaged - engage it. 4. Flow spoiler corroded. 5. Loosen net braking bow (with front left spring adjustment) 6. Limit flow spoiler movement with stop (right) 7. Net trough corroded
Netting slips on the rubber-coated roller.	<ol style="list-style-type: none"> 1. Net incorrectly installed. 2. Loosen net braking bow (with front left spring adjustment). 3. Rubber-coated roller dirty. 4. Tension steel roller (2x) 5. Flow spoiler or net trough corroded.
Net wraps around steel roller.	<ol style="list-style-type: none"> 1. The steel roller is dirty and needs cleaning.
Net on bale too loose.	<ol style="list-style-type: none"> 1. Tension net braking bow (with front left spring adjustment). 2. Run net through two flow spoilers. 3. Adjust limiting plate for upward flow spoiler movement (right)
Too few net wraps on bale.	<ol style="list-style-type: none"> 1. Knife trip quadrant jammed. 2. Wrong setting.
Net is not cut.	<ol style="list-style-type: none"> 1. Net incorrectly fitted. 2. Knife guard not removed. 3. Knife jammed or rusty. 4. Insufficient net tension. 5. Tension the spring on front left side of baler. 6. Cutting blade not in top position. 7. Hook overtravel not wide enough, adjust.
Damage to netting on bale.	<ol style="list-style-type: none"> 1. When loading the bale with the front loader, only stab the loader tines into the end of the bale. Avoid pushing the bale over the ground. 2. Check bale discharge ramp for damage. Remedy the trouble, remove any burrs. 3. Remove possibly existing burrs from rollers.
Propeller shaft activates shearing bolt/cam shaft coupling too often.	<ol style="list-style-type: none"> 1. Reduce the pressure at the pressure control valve/loosen the MPS springs. 2. Reduce speed.

IMPORTANT NOTES ON MAINTENANCE**General notes on maintenance****General****Danger!**

Repairs, maintenance and cleaning work as well as the rectification of functional faults must generally be performed with the power take-off shaft switched off and the tractor engine shut down – remove the ignition key!

Safety lock for tailgate**Danger!**

When working on the opened tailgate and inside the pressing chamber lock the tailgate with the safety lock.

Wheels / tires**Danger!**

Repair work on tires and wheels must only be performed by qualified personnel and the use of appropriate assembly tools.

With a too high tire pressure there is a danger of bursting!

- ☞ The specified tire pressure, see technical data, must be complied with.
- ☞ Do not stand next to the tire when inflating!
- ☞ Check the air pressure at regular intervals!

When working on tires make sure that the round baler is safely parked and secured against rolling (wheel chocks).

When working under the jacked up round baler no persons should be on the machine.

Ensure sufficient load bearing capacity of the lifting equipment.

Whenever assembling wheels retighten wheel nuts or bolts after the first 10 operating hours, then check for tightness every 50 operating hours. Tightening torques see Technical Data.

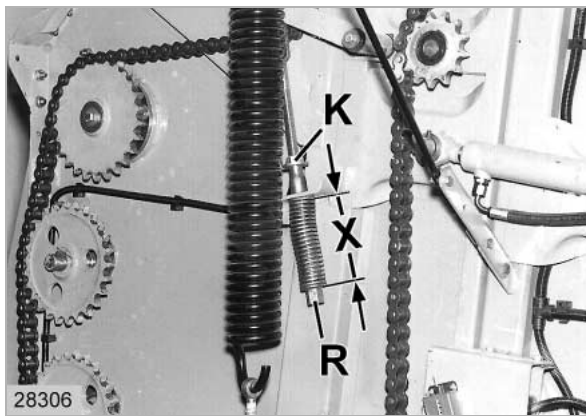

12

Spring-loaded cylinder for bale forming roller drive - tailgate

After loosening lock nut (K), adjust the guide tube (R) so that the length of the loaded spring (X) is 140 mm.

Retighten the lock nut (K) after adjustment.

(Fig. 12)

ROTOR MACHINE

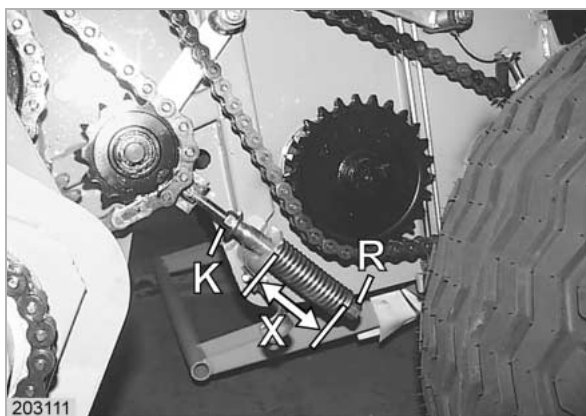

13

Spring-loaded cylinder for the bottom bale forming roller drive

After loosening lock nut (K), adjust the guide tube (R) so that the length of the loaded spring (X) is 140 mm after the lock nut has been tightened.

(Fig. 13, 14)

REEL MACHINE

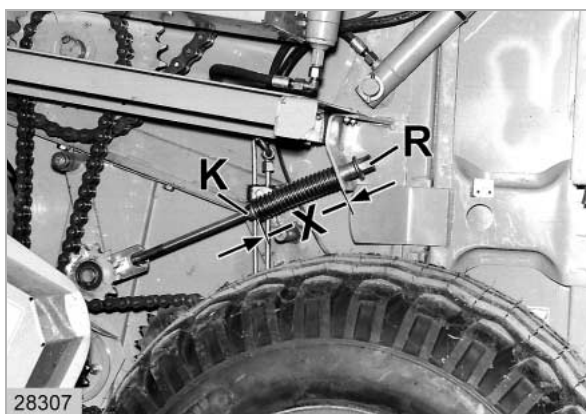

14

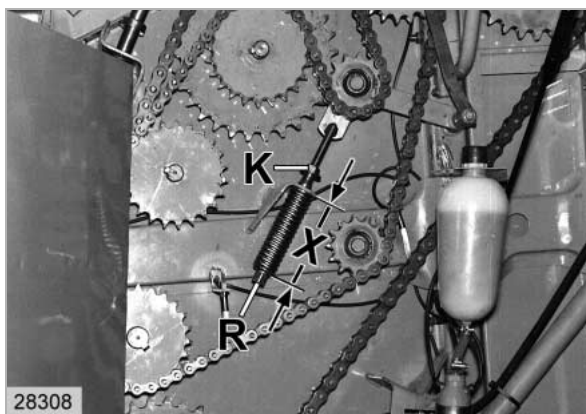

15

Adjusting the spring-loaded cylinder for the front bale forming roller drive

After loosening lock nut (K), adjust the guide tube (R) so that the length of the loaded spring (X) is 140 mm after the lock nut has been tightened.

(Fig. 15)

CUTTING UNIT

Adjusting the height of the cutting knives
(ROLLANT 250/254/255 RC)

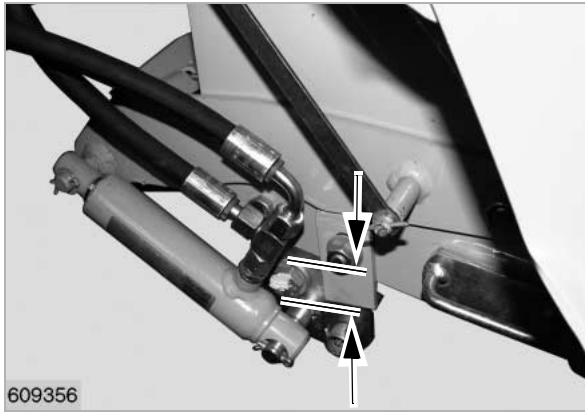

1



Attention!

Adjust the cutting knife backstop (tube) so that the cutting knives project 5 to 10 mm (X) from the base.

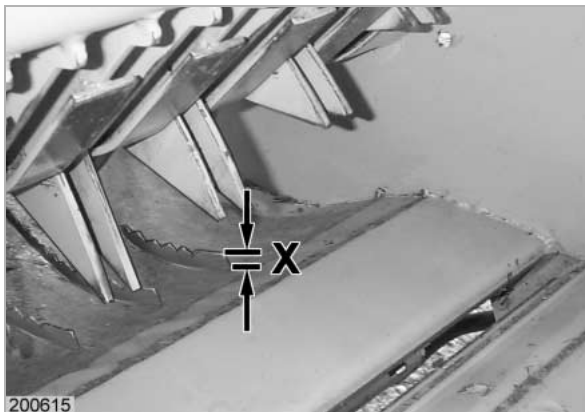

2



Danger!

Whenever working with the tailgate open and in the baling chamber, secure the tailgate with the safety lock.

Risk of injury when working in the cutting unit! – Wear gloves!

(Fig. 1, 2)

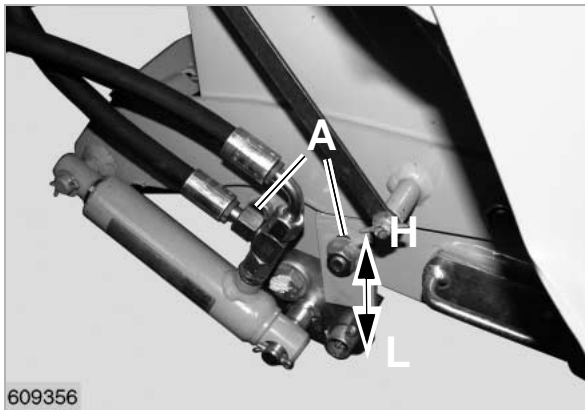

3

ROLLANT 254/255 - from 75400181/74802194

The height of the cutting unit can be adjusted. Doing this makes the blades protrude to a greater or lesser extent above the cutting floor.

- Lower position (L): If the blades are not being used for crop cutting the blades protrude 4.2 mm (X) above the cutting floor. If the blades are being used for crop cutting the distance between the tops of the blades and the rotor tube is 37 mm.
- Higher position (H): If the blades are not being used for crop cutting the blades protrude 22.3 mm (X) above the cutting floor. If the blades are being used for crop cutting the distance between the tops of the blades and the rotor tube is 19.7 mm.



Attention!

In the higher position (H) the blades always protrude above the cutting floor (approx. 22.3 mm)!

15

Lubrication plan

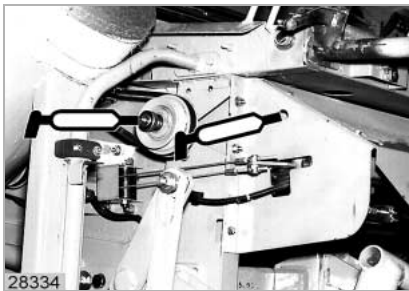
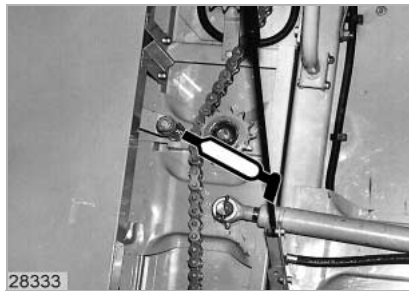
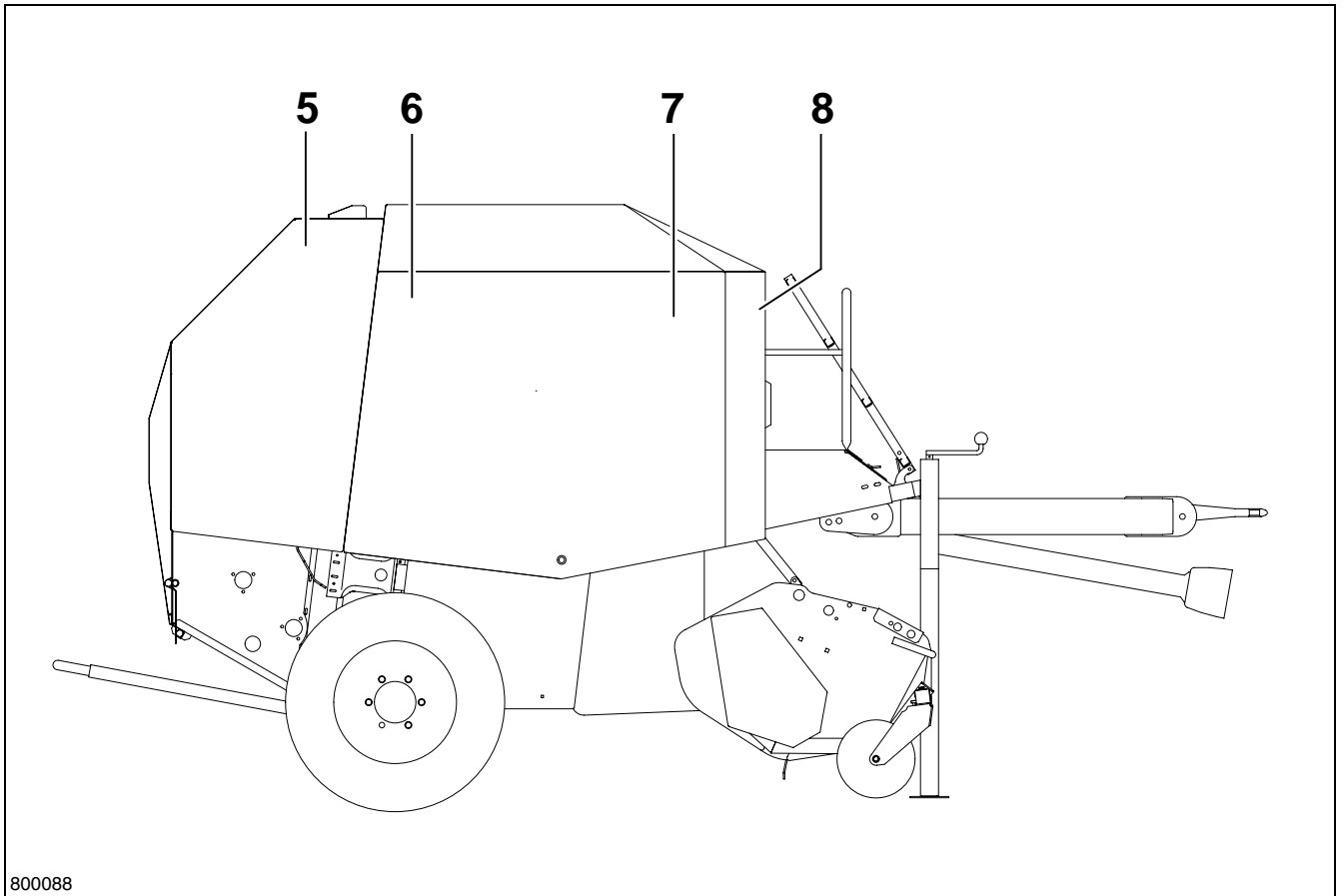

hX100

CLICK HERE TO **DOWNLOAD** THE COMPLETE MANUAL

- Thank you very much for reading the preview of the manual.
- You can download the complete manual from: www.heydownloads.com by clicking the link below



- Please note: If there is no response to CLICKING the link, please download this PDF first and then click on it.

CLICK HERE TO **DOWNLOAD** THE COMPLETE MANUAL