

CLAAS



QUADRANT 2200
QUADRANT 2200 ROTO CUT
QUADRANT 2200 ROTO CUT HD
QUADRANT 2200 FINE CUT

Operator's Manual

SERVICE & PARTS

CLICK HERE TO **DOWNLOAD** THE COMPLETE MANUAL

- Thank you very much for reading the preview of the manual.
- You can download the complete manual from: www.heydownloads.com by clicking the link below



- Please note: If there is no response to CLICKING the link, please download this PDF first and then click on it.

CLICK HERE TO **DOWNLOAD** THE COMPLETE MANUAL

Tying fault (Claas Communicator without ISOBUS)	11.5.3	Draining water from the air reservoir for the ABS	13.4.4
When starting the Claas Communicator	11.5.3	Tyres	13.5.1
During work	11.5.3	Check tight fit of wheel nuts	13.5.1
Tying fault (Claas Communicator without ISOBUS)	11.5.3	Checking wheel hub backlash	13.5.1
Tying fault 26	11.5.4	Adjusting the backlash	13.5.1
Tying fault 27/28/29	11.5.4	Hydraulic system	13.6.1
Service menu	11.6.1	Check oil level	13.6.1
Opening the service menu	11.6.1	Oil change	13.6.2
Image adjustment menu	11.6.3	Changing the hydraulic oil filter	13.6.2
Changing the contrast of the screen	11.6.3	Drives	13.7.1
Opening the time and date menu	11.6.4	Main gearbox	13.7.1
Setting time/date	11.6.4	Gearbox - hydraulic pump drive	13.7.1
Opening the memory management menu	11.6.5	Transfer gearbox - rotor / feed rake drive	13.7.2
Deleting memory	11.6.5	Upper gearbox - rotor drive	13.7.2
Opening the language selection menu	11.6.6	Lower gearbox - rotor drive	13.7.3
Setting the language selection menu	11.6.6	Gearbox - knotter drive	13.7.3
Opening the Aux. menu	11.6.7	Overload clutches and shear bolts	13.7.3
Operation	11.7.1	Free wheeling slip clutch	13.7.4
Building up/relieving the baling pressure	11.7.1	Main drive	13.7.4
Starting manual wrapping	11.7.1	Pick-up drive	13.7.6
Swivelling cutting blades in/out	11.7.2	Knotter shaft drive	13.7.7
Cutting frame up/down	11.7.3	Tying release, checking and adjustment	13.7.9
Controlling manual lubrication (Claas Communicator with ISOBUS)	11.7.4	Drive chains	13.8.1
12. After operation		Tensioning the drive chain for the pick-up drive	13.8.1
Unhitching the baler	12.1.1	Tensioning the drive chain for the feed auger	13.8.1
Parking brake	12.1.1	Adjusting the springs of the twine retainers	13.8.2
Wheel chocks	12.1.1	Adjusting the springs of the knotter hooks	13.8.2
Jack stand	12.1.2	Knotter shaft brake	13.8.3
Uncouple the hydraulic oil hoses from the hydraulic brakes	12.1.3	Adjusting the knotter pinion for correct play	13.8.3
Electrical connections	12.1.3	Needle carrier brakes	13.8.4
Disconnecting the air hoses	12.1.4	Knotter cleaning unit (standard)	13.8.4
Storage of universal drive shaft	12.1.4	Servicing the air filter	13.8.5
Cleaning the baler	12.1.5	Changing the filter cartridge	13.8.6
General	12.1.5	V-belt tension (up to serial-no. 73502778)	13.8.6
Structure and interior of baler	12.1.5	Checking the compressor console is secure (up to serial-no. 73502778)	13.8.7
Knotter	12.1.5	Checking the oil level of the compressor (up to serial-no. 73502778)	13.8.8
Piston rod	12.1.5	Changing the compressor's oil (up to serial-no. 73502778)	13.8.8
13. Maintenance		Draining water from the air reservoir for the knotter cleaning	13.8.9
Important maintenance instructions	13.1.1	Turbofan (Option)	13.8.9
Important maintenance instructions and safety regulations	13.1.1	Check oil level	13.8.9
Maintenance schedule	13.2.1	Oil change	13.8.10
Lubricants chart	13.3.1	Changing the hydraulic oil filter	13.8.10
Brake system	13.4.1	Test accumulator	13.8.11
Air operated brakes	13.4.1	Depressurising the system	13.8.11
Drain air reservoir	13.4.2	Basic setting	13.9.1
Brake cylinder	13.4.2	Setting the drives to the timing marks	13.9.1
Adjusting the brake lever	13.4.2	Tying mechanism	13.10.1
Hydraulic braking system	13.4.3	Adjusting knotter shaft and needles	13.10.1
Brake cylinder	13.4.3	Adjusting the needle height:	13.10.2
Adjusting the brake lever	13.4.3	Adjusting the top dead centre position of needles:	13.10.2
Brake linings	13.4.4	Checking the needle position relative to the ram	13.10.3
Brake anti locking system (ABS) (option)	13.4.4	Fine tuning via tying gear	13.10.4
		Correct the adjustment via the universal shaft:	13.10.4

4

Safety rules



6

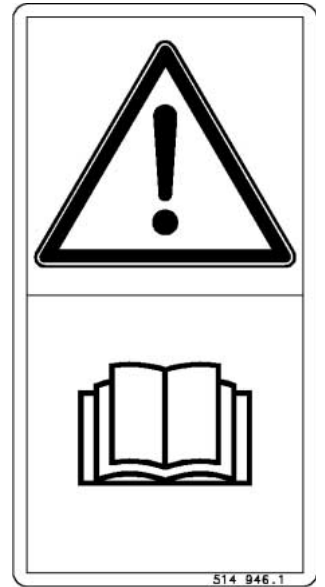

7

514 946.1 (2)

Before putting the machine into operation, read and observe the operator's manual and follow the safety instructions.

(Fig. 6, 7)



608620

37

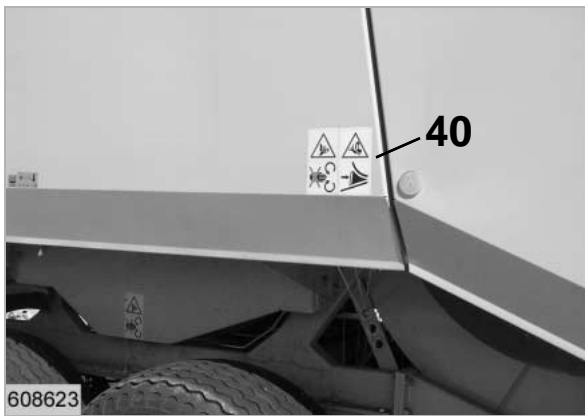

608623

38



39

516 047.0 (40)

Apply wheel chock before disconnecting or parking the machine.

(Fig. 37, 38, 39)

CLAAS QUADRANT 2200 / 2200 RC / 2200 RC HD / 2200 FC

Tying mechanism		Twine wrapping, start of wrapping automatically or manually by pushing a button on the Control Terminal/Claas Communicator.
Knotters		6 CLAAS knotters
	Cleaning	Automatic knotter cleaning using compressed air, adjustable cleaning time
	or	hydraulically driven turbo blower
Twine	Synthetic	110 - 200 m/kg
Twine boxes		For 12 balls of twine each on left-hand and right-hand side of machine
Electric twine monitor		When the twine is finished or broken, an audible signal sounds and an optical warning is given at the Control Terminal/Claas Communicator.
Turbo blower	Rotating speed of turbine	3000/min
Brakes		
Compressed air brake	Depending on country	a) Up to 40 km/h with dual-line brake system b) Up to 60 km/h with dual-line brake system (with tandem axle) c) Up to 25 km/h with single-line brake system d) Up to 62 km/h with double braking system and with brake anti locking system ABS e) up to 60 km/h in case of two-line system with steered tandem axle
	Connections on the tractor	Connections for suitable compressed air brake system are required Connector ISO 7638 (24 V) with the ABS option
Hydraulic brake		Connections for the hydraulic brake system are required
Parking brake		Operated by means of folding crank handle
Wheels		
	Tyres	Tyre pressure
	700/40-22.5 12 PR	2.0 bar
	700/45-22.5 12 PR	1.7 bar
	600/50-22.5 12 PR	2.5 bar
	555/45-17.0 146 F	3.0 bar
	500/50-17.0 140 D	2.75 bar
	500/50-17.0 14 PR	2.75 bar
	500/55-20.0 12 PR	3.0 bar
	520/50-17.0 14 PR	2.75 bar
Pick-up gauge wheel	16 x 6.50 - 8 4 PR black (M 20 x 1.5) galvanized nuts (M 20 x 1.5)	2.1 bar 343 Nm 377 Nm
Tightening torque for wheel nuts	black (M 18 x 1.5) galvanized nuts (M 18 x 1.5)	265 Nm 291 Nm

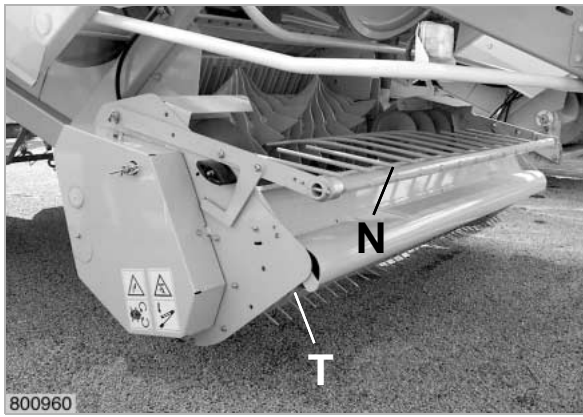

Pick up

The pick-up drum (T) picks stalks up neatly.

Deflector (N), baffle plate (P) or roller crop press (R) ensure an even intake.

The crop lifted up by the pick up drum is moved to the centre by two stub augers, situated on each side of the pick up and is then taken up by the rotor, i.e. quick removal from the pick-up.

A pickup with continuous screw (A) is optionally available. This also conveys the crop to the middle and paddles (B) move it directly into the rotor.

5

The pick up can be raised for transport and lowered for operation using the tractor hydraulic system.

(Fig. 5, 6, 8, 9)



6

Swath spreader (optional)

A swath spreader may be installed additionally to even out swaths.

(Fig. 7)



7

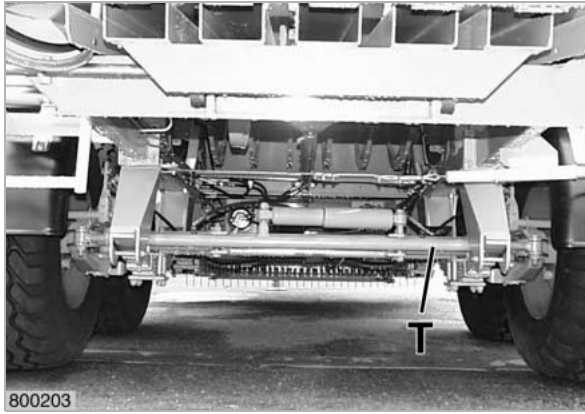

37

Steered tandem axle (option from serial-no. 73501657)

The steered tandem axle may be used as rigid or steered tandem axle (T).

The setting for rigid or steered position is made at the control unit on the tractor.

**Danger!**

During road travel, when reversing and when used on sloped fields the tandem axle must be set to rigid position.

For normal work on fields the tandem axle is set to floating position.

(Fig. 37)

Hitching up the baler

Hydraulic system:



Attention!

Have the hydraulic hose (or the hydraulic hoses in case of a hydraulic brake) adapted to the correct length to suit the tractor. Adaptions of hydraulic hoses must only be carried out by specialist workshops.

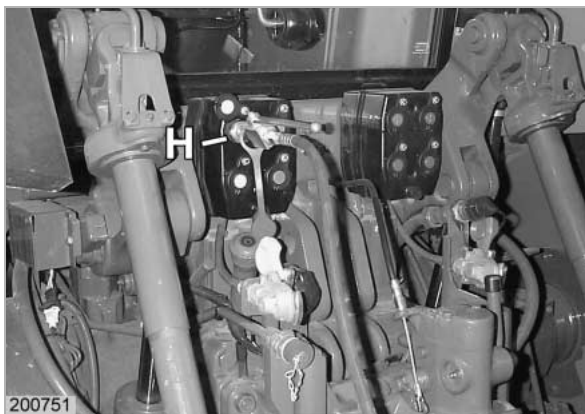

8

Connect the hydraulic hose (H) for hydraulic pick up and jack stand operation to a single acting control valve on the tractor.

(Fig. 8)

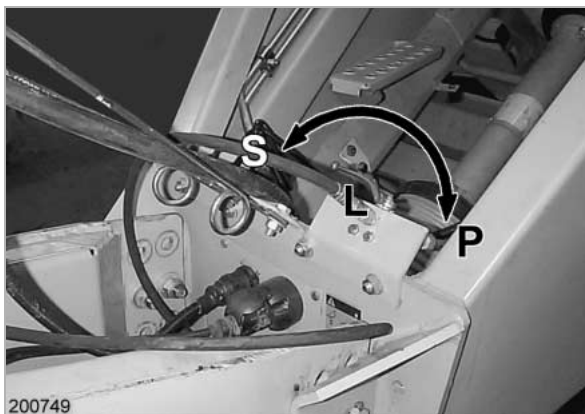

9

Raise the baler to the required hitching position by means of the tractor hydraulic system.

To this end, the lever of the control valve (L) must be in position (S) »Retract / extend jack stand« see also page 8.1.2.

(Fig. 9)

From machine serial no. 73500927



10

Hitch up the big square baler and attach the safety rope (up to serial-no. 73501326). Retract jack stand (F) completely after hitching up, using the tractor hydraulic system.

If hydraulic oil is still cold, retracting the jack stand will take more time than usual.

(Fig. 10, 11)



Danger!

Beware of pinch and shear points when moving the jack stand.

BRAKES

Air operated brakes



Attention!

The length of the air hoses must be adapted to the tractor.

Adapting the air hoses may only be carried out by a specialist workshop.

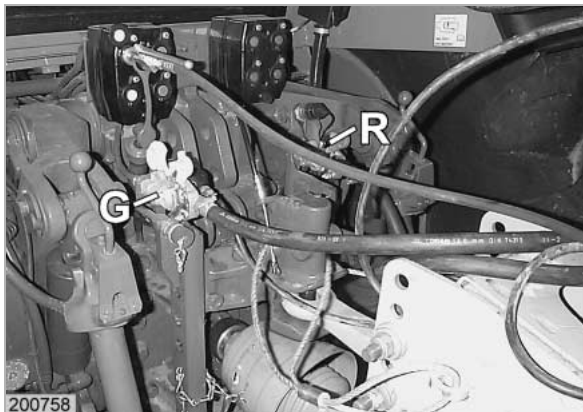

1

Connecting the air hoses:



Attention!

First connect the yellow coupling head (G) and then the red coupling head (R).

(Disconnect the air hoses in reverse order, see chapter »After operation«).

(Fig. 1)

Two line braking system:

Connect air hoses to the quick release couplings on the tractor provided for that purpose.

Single line braking system:

Connect air hose to the quick release coupling on the tractor provided for that purpose.



Note!

The coupling heads must engage securely. The hoses must be in the correct position.



1

EQUIPMENT

Ladder

Before climbing onto the baler for maintenance work or to eliminate malfunctions, always shut off tractor engine, remove ignition key and lock the flywheel.

(Fig. 1)

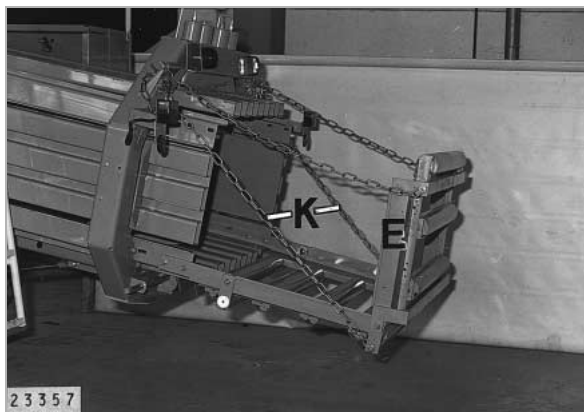

2

Roller chute

Transport with big bale in bale chamber:



Danger!

When transporting the big square baler on public roads and lanes, the rear section (E) of the two piece bale chute must always be folded and fastened in vertical position with chains (K).

(Fig. 2)



3

Transport without big square bales:



Attention!

When transporting the baler without big square bale, both sections of the two piece roller chute are to be raised vertically and secured with chains (K).

(Fig. 3)

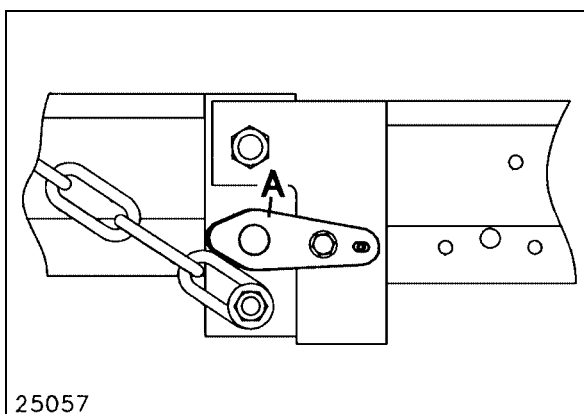

4

Bale chute locking device

Always release latch (A) before raising the rear bale chute vertically.

Then fold bale chute forward.

The latch (A) locks automatically in position when the rear bale chute is lowered to the horizontal position.

The latch keeps the rear bale chute rigid in the horizontal position.

(Fig. 4)

from serial-no. 73501657

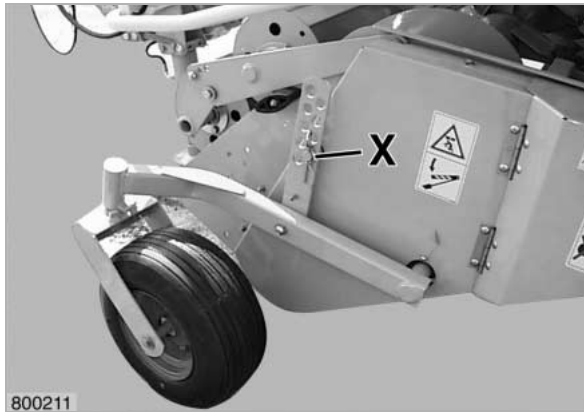

8

Work in straw:

Raise the supporting wheels as high as possible or even remove them so that they do not come in contact with the stubbles.

Lower the pick up until the tines are at stubble height.

Lock the depth stops in the corresponding position. Raise pick up slightly to do this, if required.

(Fig. 1, 2, 3, 6, 7, 9)

up to serial-no. 73500441

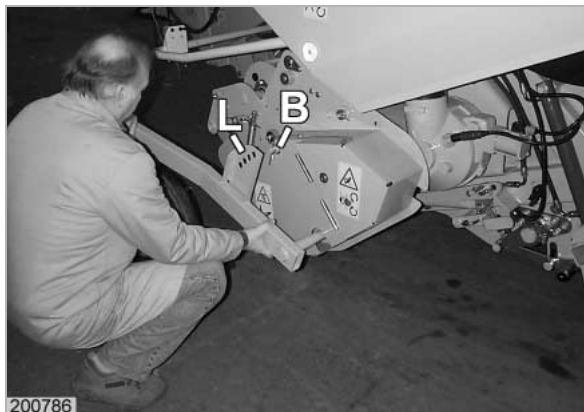

9

Gauge wheels

Install and remove gauge wheels:

up to serial-no. 73500441:

Push the bearing necks of the gauge wheels through the bearings and lock them in the hub.

At the same time, push the mounting plate (L) located on the respective supporting arm on the pin (B), using the desired height adjustment hole, and secure with the spring clip.

Proceed in reverse order for removing the gauge wheels.

(Fig. 9)

from serial-no. 73500442 to 73501656

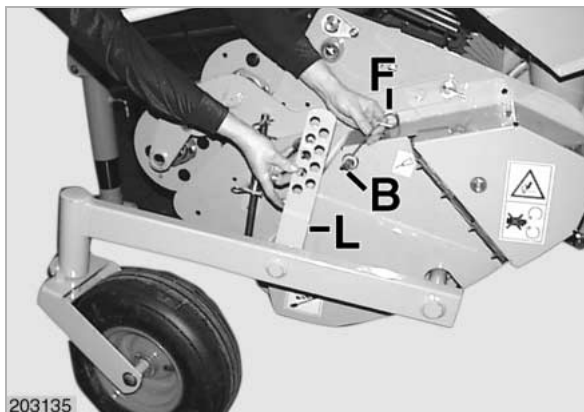

10

from serial-no. 73500442 to 73501656:

For installation push the bearing journals (C) of the support wheels through the bearings and secure them from the back with linch pins (K).

Push the mounting plate (L) located on the respective supporting arm on the pin (B), using the desired height adjustment hole, and secure with the spring clip (F).

Perform disassembly in reverse order.

(Fig. 10, 13)



41

Dummy knife holder (optional)

Removed knives or dummy knives (H) may be stored on the blanking knife holder in the space at the rear end of the right hand or left hand twine box (J).

(Fig. 41)

If the cutting blades are not to be used for a longer period of time, they should be replaced by dummy blades in order to avoid unnecessary wear of the cutting edges.

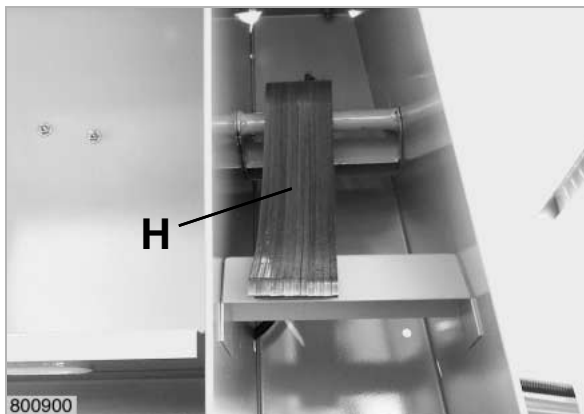

42

Dummy blades

Disassembled blades must be replaced by dummy blades.

(Fig. 42)



43

Adjusting two-piece bale chute

Fold the two-piece bale chute down before use and hook on with chains (L). Hook all four chains in so that the chute is evenly suspended.

Adjust the chute so that it is as level as possible with the bottom of the bale chamber.

(Fig. 43)



44

Adjusting the hydraulic bale chute (option)

Tilt the hydraulic bale chute down before starting work and attach both chains (P) so that the chute is evenly suspended.

Adjust the chute so that it is as level as possible with the bottom of the bale chamber.

(Fig. 44)

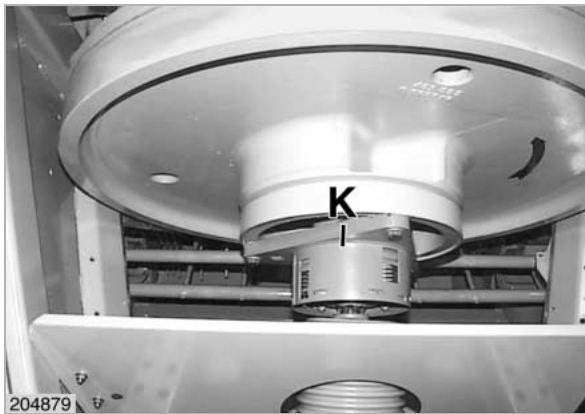

Free wheeling slip clutch



Attention!

Start at reduced ground speed when breaking in the clutch (K) in a new baler.

This rule is also to be adhered to after each opening and / or venting of the clutch.

(Fig. 1)

- 1 The torque which can be transmitted will decrease following frequent consecutive slipping due to the generated heat. After a suitable cooling period, the torque and consequently the full capacity of the clutch is restored when it is warm to touch.

Clutch linings which have burned during unpermitted slip periods must be replaced in accordance with assembly instructions.



Note!

The clutch must be vented before each season and after any prolonged standstill (see »Maintenance«).

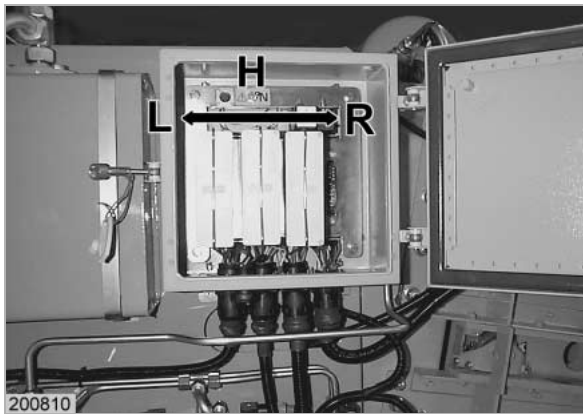

6

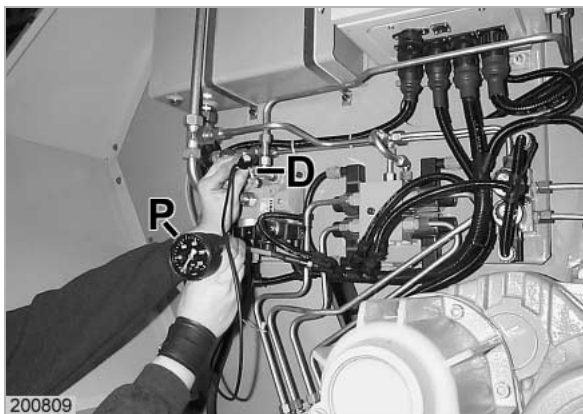

7

Setting the baling pressure

1. Remove intermediate universal drive shaft from angle drive of hydraulic pump.
2. Disconnect plugs (A, B and C). If the power supply from the tractor is interrupted, re establish the power supply. Connection is also possible to socket outlet (K).

(Fig. 3, 10)

3. Connect pressure gauge (P) to measuring point (D).

(Fig. 7)

4. Activate emergency switch (H) by flipping it to the left (L).

R = Normal operation – switch to the right
 L = Emergency operation – switch to the left

(Fig. 6)

5. Let the baler run at idle speed and press valves (A and B) at the same time, using a pin (2 -3 mm diameter). To start with, set the baling pressure a little higher than required. After this, lower baling pressure to the desired value, using valve (C). Check pressure with pressure gauge.

(Fig. 10)

6. Re install plugs (A, B and C). The emergency switch (H) remains activated.

(Fig. 6, 10)

7. Re install intermediate universal drive shaft.

The baling pressure is active and work may be started.

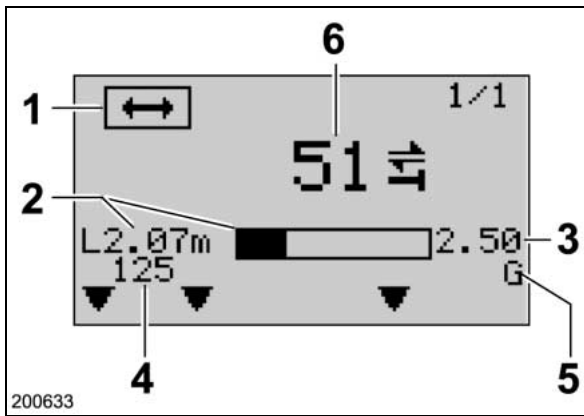

4

Group 1 / Dia 1

- 1 Bale length
- 2 Present bale length
- 3 Set bale length
- 4 Bale counter (number of completed bales)
- 5 Option central lubrication system (during operation)
- 6 Ram strokes per minute 1/min.

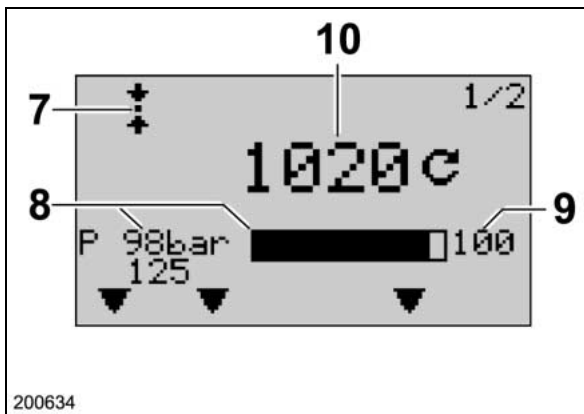

5

Group 1 / Dia 2

- 7 Bale density
- 8 Display, present pressure
- 9 Display, pre set pressure
- 10 Main drive speed display

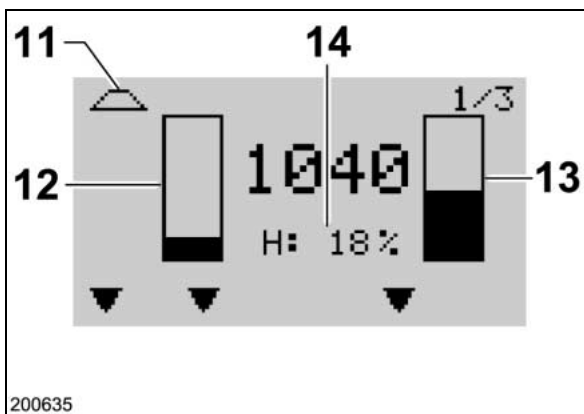

6

Group 1 / Dia 3

- 11 Bale shape
- 12 Bale chamber loading, left hand side
- 13 Bale chamber loading, right hand side
- 14 Moisture measurement

CLICK HERE TO **DOWNLOAD** THE COMPLETE MANUAL

- Thank you very much for reading the preview of the manual.
- You can download the complete manual from: www.heydownloads.com by clicking the link below



- Please note: If there is no response to CLICKING the link, please download this PDF first and then click on it.

CLICK HERE TO **DOWNLOAD** THE COMPLETE MANUAL

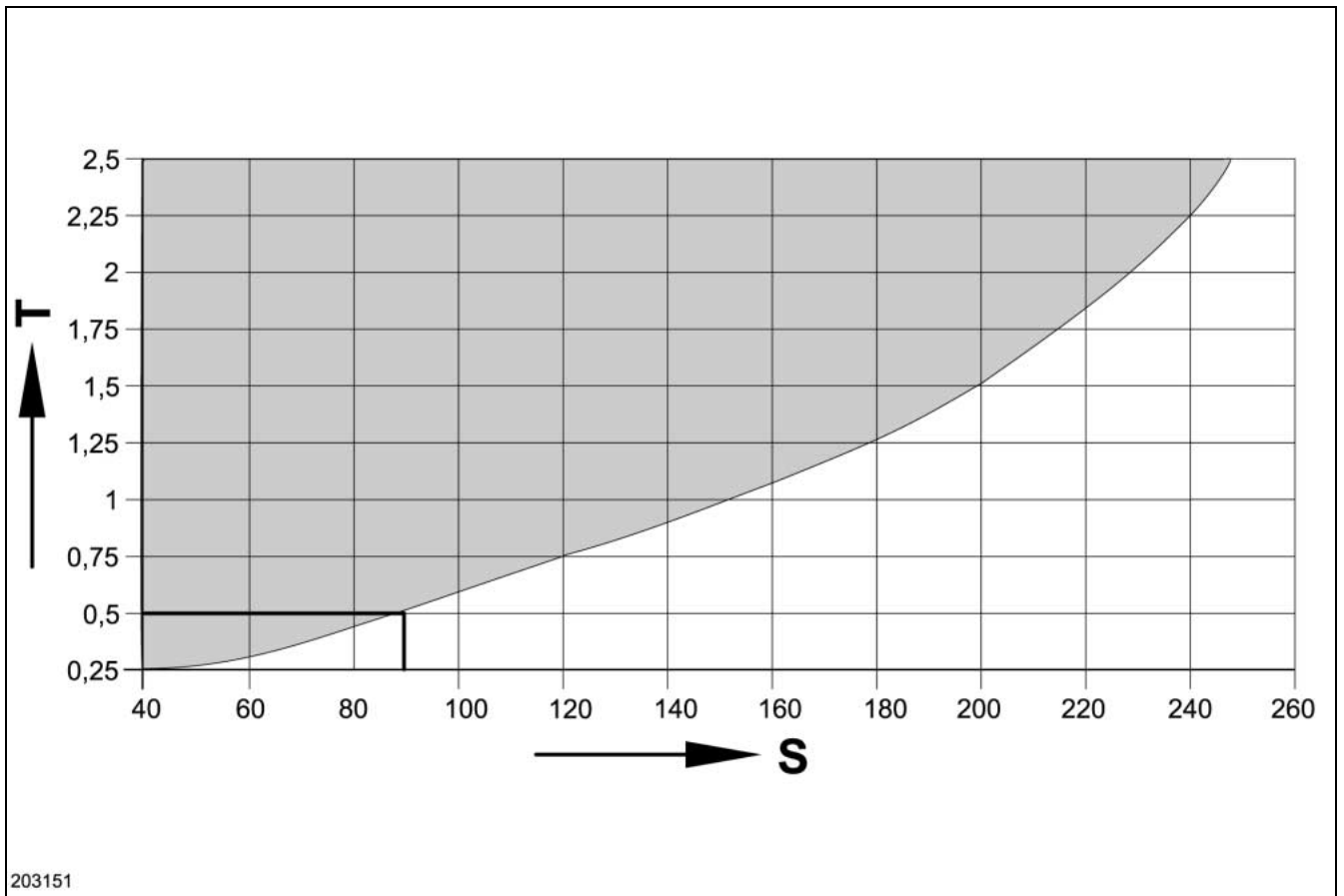

Length of knotter air blast time

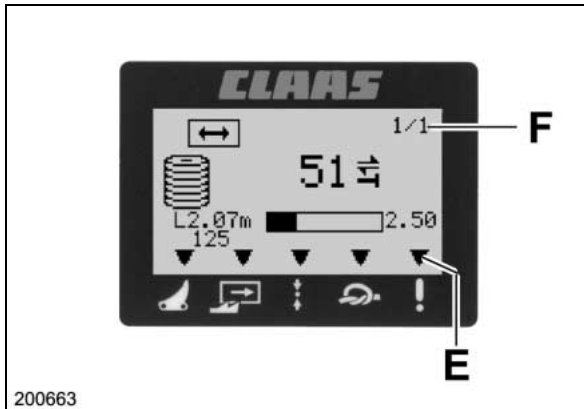

1

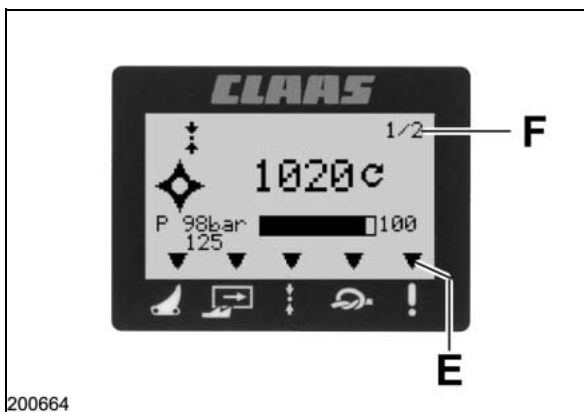

2

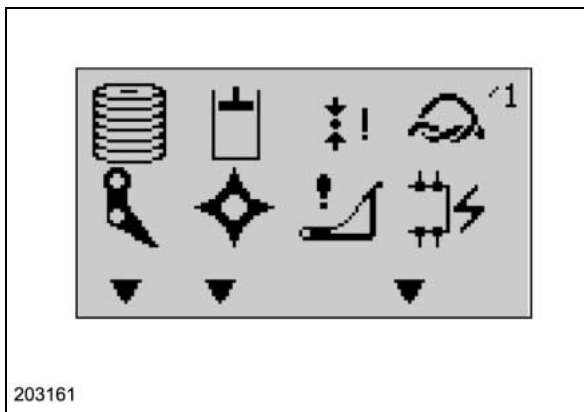

3

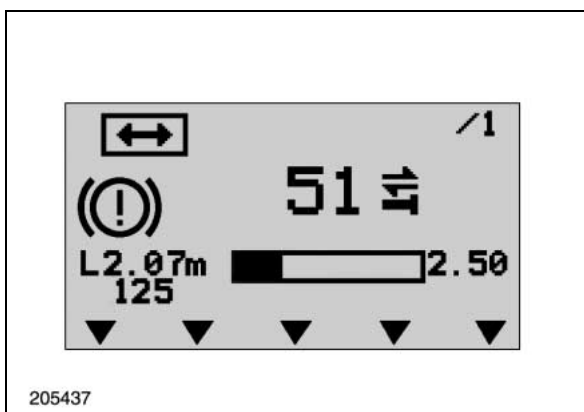

4

FAULT DISPLAY

When a fault develops, then the status display (E) will light up and a warning tone will be sounded.

Depending on the fault priority, the relevant symbol will be displayed in the menu »Bale length« (F will be on 1/1) or »Bale density« (F will be on 1/2).



Should a fault develop, press this key until the fault display is shown.

The symbols have the following meanings:



Twine broken



Fault with the hydraulics



Problem in the tying



Feed rake fault



Rotor fault



Cutting floor not closed



System fault



Overload



Hydraulic flywheel brake

Repair the fault (see »Problems, cause and remedy«).



With this key, press once to switch the display from displaying symbols to text.



Keys and incremental encoder

Incremental encoder

The incremental encoder (2) is a mobile part with double function:

- The incremental encoder enables selection of a menu entry and to change its value. The selection appears in a frame.
- The selection is confirmed by pressing the incremental encoder.

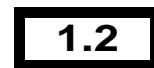
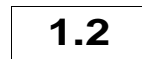
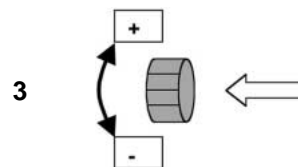

By turning the incremental encoder the different specified setpoints are selected and highlighted by a frame. Pressing the incremental encoder activates the pre-selected value and highlights it by means of a larger frame.

The value is changed by turning the incremental encoder. Pressing the incremental encoder confirms the adjusted value. The

frame around the value is reduced in size.

Perform these steps for each value to be changed.

Softkeys

The softkeys (5) work in connection with the auxiliary screen display.

The desired function is activated by pressing the softkey.

(Fig. 3).



Setting the baling pressure

i Note!

The baling pressure is adjustable from 5 to 210 bar.

Opening the »adjustment menu«

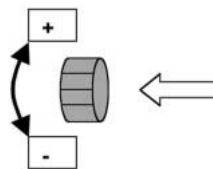

Turn the incremental encoder (I), until the setpoint (C) appears surrounded by a frame.

120

120

Press the push button in the incremental encoder, the frame appears enlarged.

Keep turning the incremental encoder, until the desired baling pressure is displayed. Press the push button to confirm the set baling pressure (it is thereby stored).

(Fig. 3)

SERVICE MENU

The service menu provides the possibility to open six menus.

1 = Information menu



2 = Image adjustment menu



3 = Time and date menu



4 = Memory management menu



5 = Language selection menu



6 = Aux. menu



802015

Opening the service menu

Switch on the CLAAS COMMUNICATOR by pressing the On/Off-key (A).



Note!

The CLAAS COMMUNICATOR will automatically enter into the »application menu«.

1 Press the selection switch »application window« (B).

The display shows the control window (1) inside a frame.

(Fig. 1, 2)



802040

2



3

Cutting frame up/down



Attention!

When opening the cutting frame, consider the way the baler is hitched to the tractor (top or bottom hitching) and the ground conditions (heaps of soil or large stones). Under no circumstances must the opened cutting frame touch the ground or lift the baler.

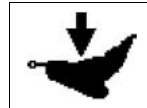

Press the softkey (J) to lower the cutting frame.

With a momentary pressure the cutting frame is opened by 20° to a height of 10 cm.

Applying pressure for a longer time opens the frame completely.

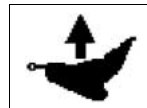

Press the softkey (H) to lift the cutting frame.

With a momentary pressure the frame is closed for a few centimetres.

Applying pressure for a longer time closes the frame completely.



Attention!

When opening the frame make sure that the frame does not hit the ground.

(Fig. 3)

13

Maintenance

LUBRICANTS CHART

Components	Type of lubricant	Capacity	SAE class	Change intervals	Check
Hydraulic system	Multigrade hydraulic oil Shell Hydrol HV 46 Tellus T 46 Donax TM Fuchs Renolin D 46 HV Wintershall HVG 46	approx. 17 litres		Initially after 100 working hours, thereafter once a year (500 working hours)	Weekly
Main gearbox	Multigrade transmission oil conforming to (MIL-L-2105) API-GL-4-90	approx. 24 litres	90	Initially after 50 working hours, thereafter every 300 working hours or once a year	Weekly
Gearbox - hydraulic pump drive	Multigrade transmission oil conforming to (MIL-L-2105) API-GL-4-90	approx. 4 litres	90	Initially after 250 working hrs., or after the first season, thereafter every 500 working hours or once a year	Weekly
Transfer gearbox - rotor / feed rake drive (with external feed rake clutch)	Multigrade transmission oil conforming to (MIL-L-2105 B) API-GL-5-90	approx. 5 litres	90	Initially after 50 working hrs., thereafter every 500 working hours or once a year	Weekly
With integrated feed rake clutch		approx. 6.3 litres			
Upper gearbox - rotor drive (with external feed rake clutch)	Multigrade transmission oil conforming to (MIL-L-2105 B) API-GL-5-90	approx. 0.8 litres	90	Initially after 50 working hrs., thereafter every 500 working hours or once a year	Weekly
With integrated feed rake clutch		approx. 0.7 litres			
Lower gearbox - rotor drive	Multigrade transmission oil conforming to (MIL-L-2105) API-GL-4-90	approx. 2.5 litres	90	Initially after 250 working hrs., or after the first season, thereafter every 500 working hours or once a year	Weekly
Gearbox - knotter drive	Multigrade transmission oil conforming to (MIL-L-2105) API-GL-4-90	approx. 1.25 litres	90	Initially after 50 working hrs., thereafter every 300 working hours or once a year	Weekly
Compressor (up to serial-no. 73502778)	Multigrade engine oil (HD oil)	175 ml	15W40	Every 50 working hours	Daily

DRIVES



Attention!

Dispose of old oil in a way that is harmless to the environment and in accordance with environmental regulations.

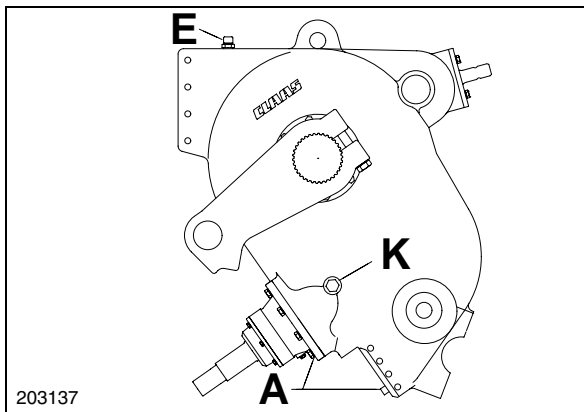

1

Main gearbox

Checking the oil level:

K = Oil level plug

Oil change:

A = Oil drain plug

E = Filler plug

(Fig. 1)

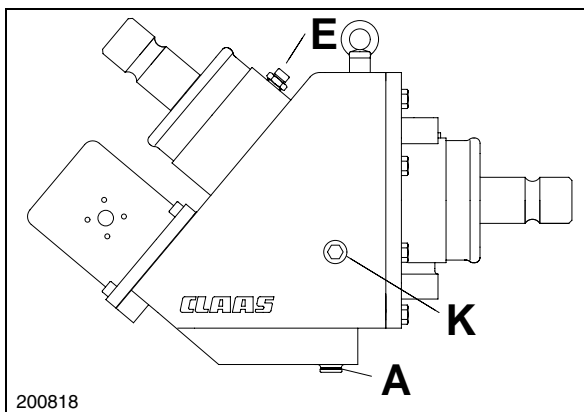

2

Gearbox - hydraulic pump drive

Checking the oil level:

K = Oil level plug

Oil change:

A = Oil drain plug

E = Filler plug

(Fig. 2)

To machine no. 73501656

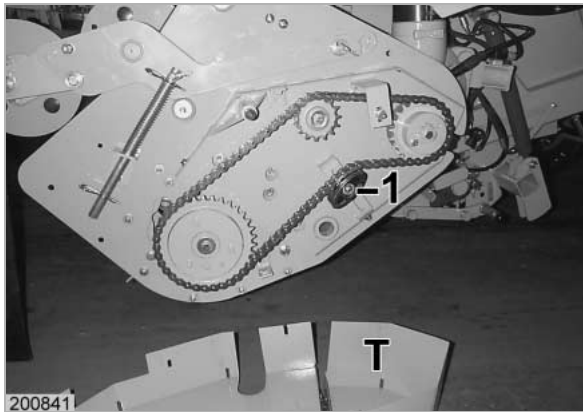

1

From machine serial no. 73501657

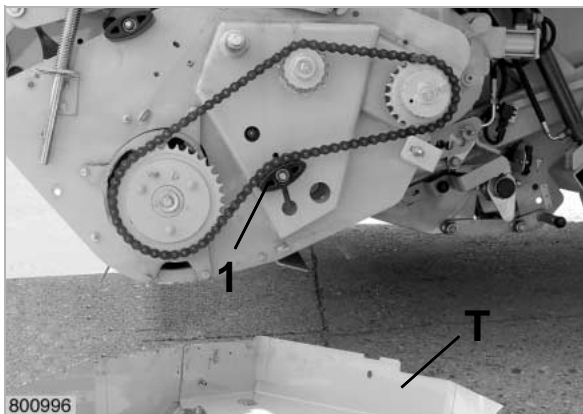

2

Continuous screw up to serial-no. 73502116

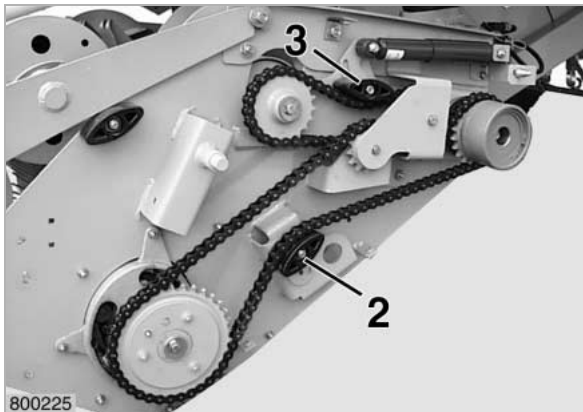

3

Continuous screw from serial-no. 73502117

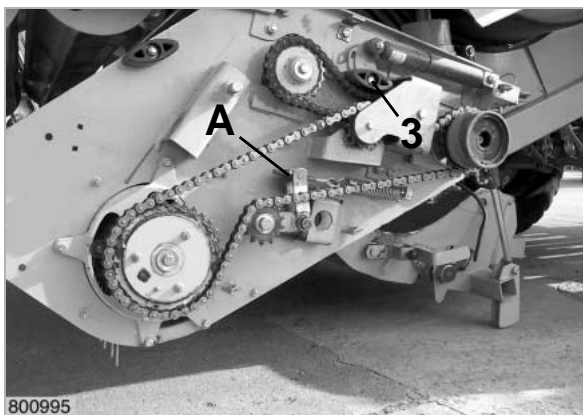

4

DRIVE CHAINS

Tensioning the drive chain for the pick-up drive

To tension the drive chain, remove guard (T) or (S).

On a continuous screw slacken tensioning screw (1) or (2) and push the tensioning block up.

On machines from serial-no. 73502117 with continuous screw the tension is adjusted by turning nuts (A) accordingly.

After tensioning, retighten the tensioning screw and re-fit the guard.

(Fig. 1, 2, 3, 4)

Tensioning the drive chain for the feed auger

To tension the drive chain, remove guard (T) or (S).

On a continuous screw slacken tensioning screw (1) or (3) and push the tensioning block down.

After tensioning, retighten the tensioning screw and re-fit the guard.

(Fig. 3, 5, 6, 7)

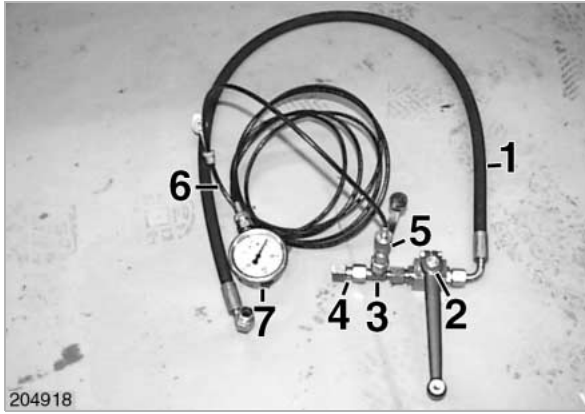

204918

28

Test accumulator

Test kit:

Pos.	part no.	Description
1	667 105.0	HD pipe
2	825 495.0	Ball tap valve
3	238 890.0	Union
4	660 608.0	Pipe
5	683 656.1	Pressure test fitting
6	181 951.1	Pressure tes hose
7	181 839.0	Test gauge (250 bar)

(Fig. 28)

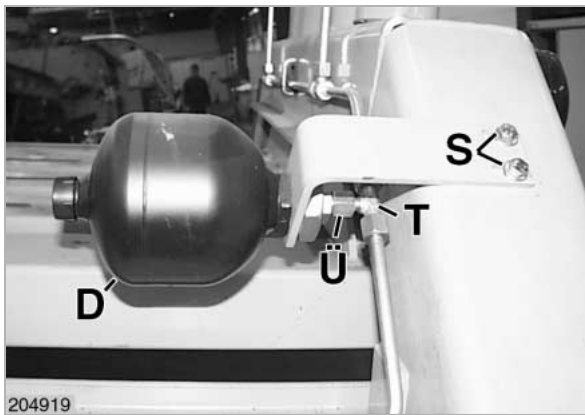

204919

29

Depressurising the system

Screw out the screw (S), the cap nut (Ü) and then remove the accumulator (D) along with the angle.



Environment!

Contain spillage of oil in a suitable container.

(Fig. 29)

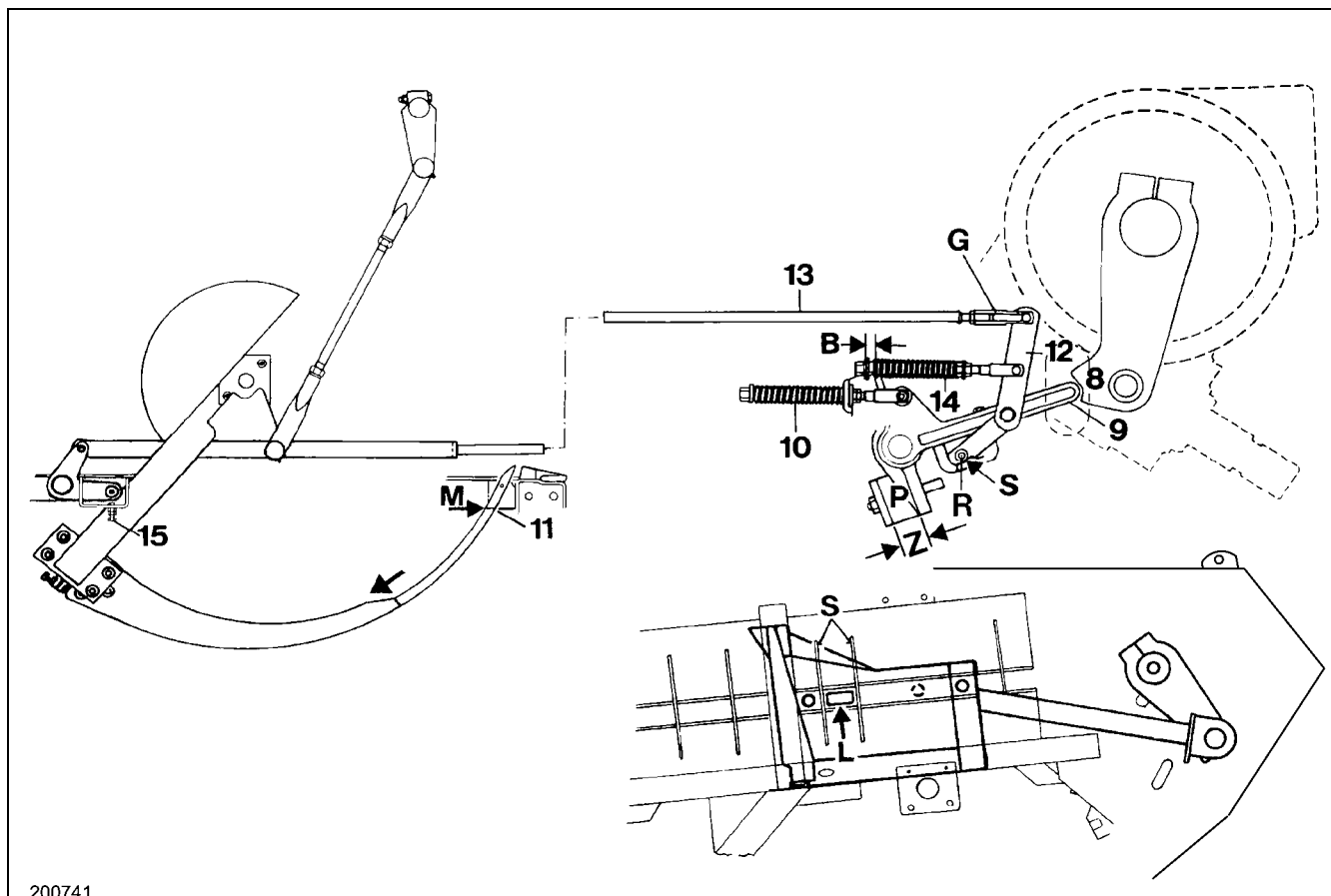

200741

11

Ram stop

The ram stop is fitted next to the main drive gearbox. The ramstop protects the needles against damage when these stop in the bale chamber. If this occurs, the shear bolt of the main drive will shear off.



Danger!

The ram/ needle synchronization has to be checked and corrected, if necessary, prior to the alignment of the ram stop.

Setting the ram stop:



Attention!

The rubber springs (P) must be set to (Z) 57.5 ± 1 mm.

The rubber pressure springs must all be of same colour and should always be replaced as a set.

PROPOSALS FOR WINTER STORAGE

Preparation for winter storage of the big square baler after the harvest is necessary to maintain the invested capital for this machine over a long time. Proper and thorough care and maintenance in combination with the repair of worn or damaged parts will save money and time during restarting.

1. Clean all trash and dirt from the big square baler.
2. Clean all bearings externally from grease and dust.
3. When using high pressure/ steam cleaning equipment for cleaning remove the Control box/ Claas Communicator from the baler
4. Thoroughly lubricate all grease points until the grease protrudes from the bearings (see Lubrication Chart). Then run the big square baler for a short time.
5. Clean and grease the chains.
6. Check the big square baler for wear and damage and have it repaired.
7. Paint tyres with a protective-type paint to prevent the rubber from deteriorating.
8. Store the baler under cover in a dry and weather protected place, which not used for the storage of fertilisers.
9. Jack the big square baler up to relieve the tires and adjust the specified tire pressure. If the big square baler is not jacked up, the specified tire pressure must be increased by 1.0 bar.
10. Grease all bare metal parts on the tying mechanism and in the bale chamber.
11. Retract the hydraulic cylinder and grease the piston rod.
12. Clean corroded spots and repair paint damage.

Permissible grease types

Supplier	Designation
CLAAS	ET-Nr.: 0241 736.0
FINA	»Marson EPL 2«
ARAL	»Aralub HLP 2«
FUCHS	»Rendit TEP 2«
SHELL	»Retinax EP 2« or »Alvania G3«
DEA	»Glisando EP 2«
AVIA	»Avilup Spezialfett EP«
FAG	»Arcanol L 135 V«
SKF	LGEP 2

Filling the handlever-type grease gun

Installing the cartridge:

**Note!**

Meticulous cleanliness is a MUST.

Only use 400 grammes cartridges to charge the handlever-type grease gun.

Charging with other grease guns:

Clean connections before charging by means of other grease guns.

To avoid contamination of the grease, the handlever-type grease gun must never be filled by hand. If this is ignored, the grease banks will be damaged.

LUBRICANTS AND NOTES

All grease points which are part of the central lubrication system are marked with a »Z« in the lubrication chart.

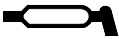

Brandname grease

Examples:

Supplier	Designation
CLAAS	ET-Nr.: 241 736.0
FINA	»Marson EPL 2«
ARAL	»Aralub HLP 2«
FUCHS	»Rendit TEP 2«
SHELL	»Retinax EP 2«
	or
	»Alvania G3«
DEA	»Glisando EP2«
AVIA	»Avilup Spezialfett EP«
FAG	»Arcanol L 135 V«
SKF	LGEP2



Biodegradable chain oil

Example:

Supplier	Designation
CLAAS	»Chain oil Bio HEES 46«



Optional extras



Grease the clutch with max. 20 g of grease (approx. 10 strokes out of a handlever type grease gun)

A
up to serial-no. 73501656

Machine without central lubrication

S
with continuous screw

T
Tandem axle, steered

h⌚5

Every 5 working hours

h⌚100

Every 100 working hours

h⌚10

Every 10 working hours

a-h⌚250







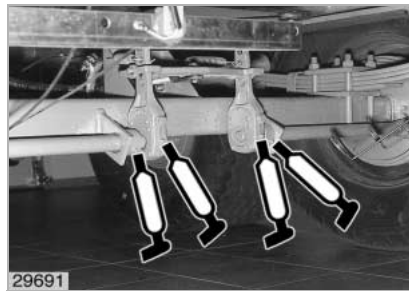
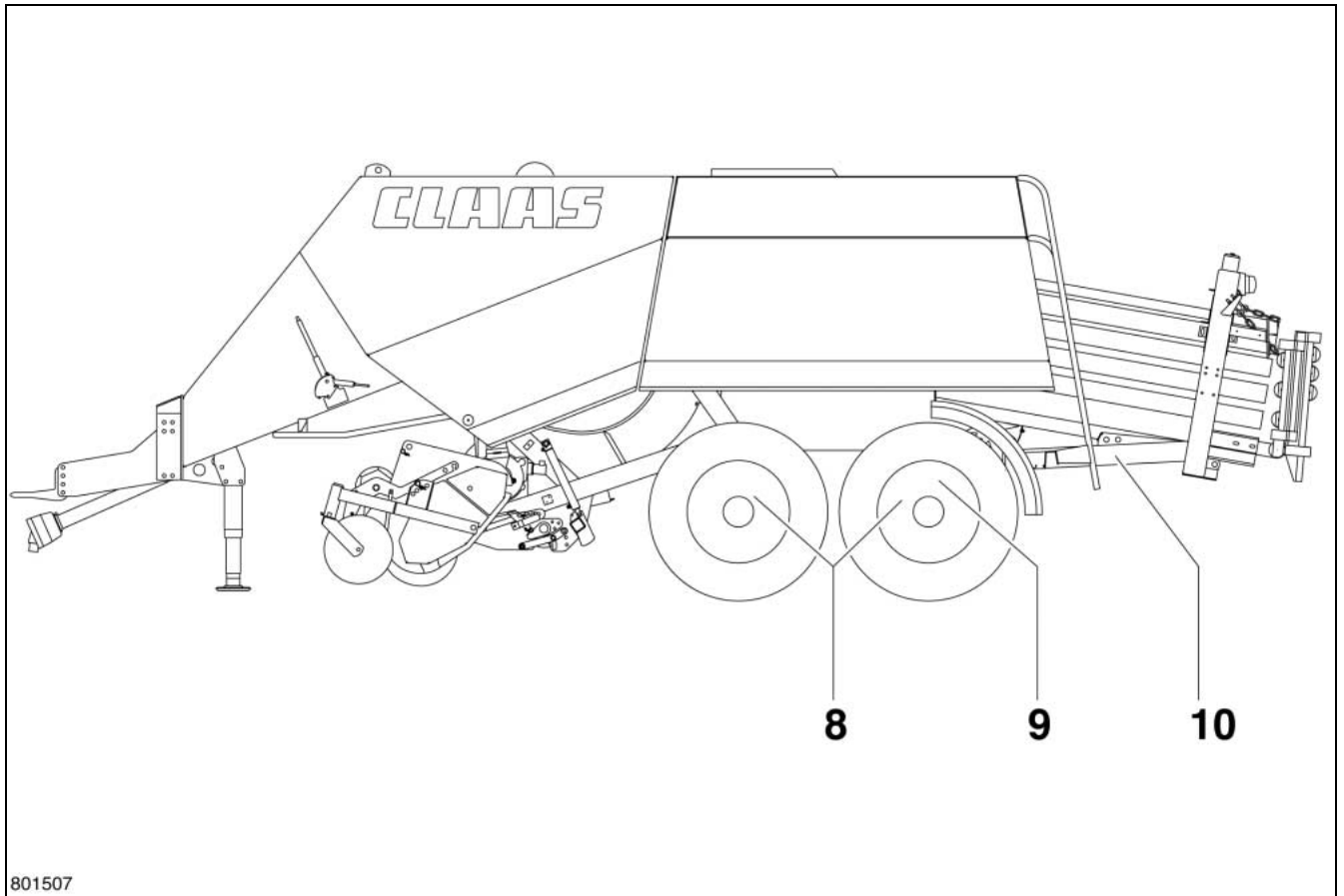



Once a year
(250 working hours)

h⌚50

Every 50 working hours



hX100

Problem / Symbol on Display	Cause	Remedy
Feed rake fault  	Feed rake overload	For help see page 9.1.4
Rotor fault  	Rotor overload	Remedy see page 9.1.5
Cutting floor not closed  	-	Close the cutting floor manually via the Control Terminal, see page 10.6.2 or via the Claas Communicator, see page 11.7.3
Flywheel brake  	Flywheel brake applied	Release flywheel brake
System fault  	Wrong connection between Control Terminal/Claas Communicator and baler.	Check if all connectors between the control terminal/Claas Communicator and the baler are properly connected.

CLICK HERE TO **DOWNLOAD** THE COMPLETE MANUAL

- Thank you very much for reading the preview of the manual.
- You can download the complete manual from: www.heydownloads.com by clicking the link below



- Please note: If there is no response to CLICKING the link, please download this PDF first and then click on it.

CLICK HERE TO **DOWNLOAD** THE COMPLETE MANUAL