

CLAAS



ARION 630C-620C-610C

Operator's manual

SERVICE & PARTS

CLICK HERE TO **DOWNLOAD** THE COMPLETE MANUAL

- Thank you very much for reading the preview of the manual.
- You can download the complete manual from: www.heydownloads.com by clicking the link below



- Please note: If there is no response to CLICKING the link, please download this PDF first and then click on it.

CLICK HERE TO **DOWNLOAD** THE COMPLETE MANUAL

E - TRANSMISSION

GEARBOX

| | | |
|----------|---|--------------|
| 1 | CHARACTERISTICS | E. 4 |
| 2 | FORWARD SPEEDS | E. 5 |
| 3 | DISPLAY | E. 8 |
| 4 | SAFETY | E. 9 |
| 4.1 | REVERSER NEUTRAL | E. 9 |
| 4.2 | TRANSMISSION NEUTRAL | E. 10 |
| 4.3 | PROTECTION OF MECHANICAL PARTS | E. 12 |
| 5 | STARTING THE TRACTOR | E. 13 |
| 5.1 | CLUTCH | E. 13 |
| 5.2 | SELECTION OF MOVEMENT DIRECTION | E. 14 |
| 6 | MANUAL GEAR CHANGES | E. 15 |
| 6.1 | WORK MODE | E. 15 |
| 6.2 | ROAD MODE | E. 16 |
| 6.3 | START RATIO | E. 17 |
| 7 | AUTOMATIC GEAR CHANGES | E. 19 |
| 7.1 | AUTOMATIC SPEED ADAPTATION (SPEED MATCHING) | E. 19 |
| 8 | RATIO MANAGEMENT | E. 20 |
| 9 | CREEP GEAR RANGE | E. 21 |
| 9.1 | OPERATION | E. 21 |
| 9.2 | OPERATION | E. 21 |

REAR AXLE

| | | |
|----------|---|--------------|
| 1 | CHARACTERISTICS | E. 24 |
| 2 | DISPLAY | E. 25 |
| 3 | PROTECTION OF MECHANICAL PARTS | E. 26 |
| 3.1 | OPERATION | E. 26 |
| 4 | DIFFERENTIAL LOCK | E. 27 |
| 4.1 | RECOMMENDATIONS | E. 27 |
| 4.2 | GENERAL | E. 27 |
| 4.3 | DIFFERENTIAL LOCK | E. 27 |
| 5 | BRAKES | E. 29 |
| 5.1 | SERVICE BRAKES | E. 29 |
| 5.2 | HANDBRAKE (AUXILIARY AND PARKING BRAKE) | E. 29 |
| 6 | TRAILER BRAKE | E. 31 |
| 6.1 | HYDRAULIC BRAKE | E. 31 |
| 6.2 | PNEUMATIC BRAKE | E. 32 |



3 MOTOR INFORMATION PLATE

6597

Motor information plate

The engine identification plate (3) can be seen from behind the mount (2) (Right-hand side of the engine).

This plate contains the engine type and serial number.

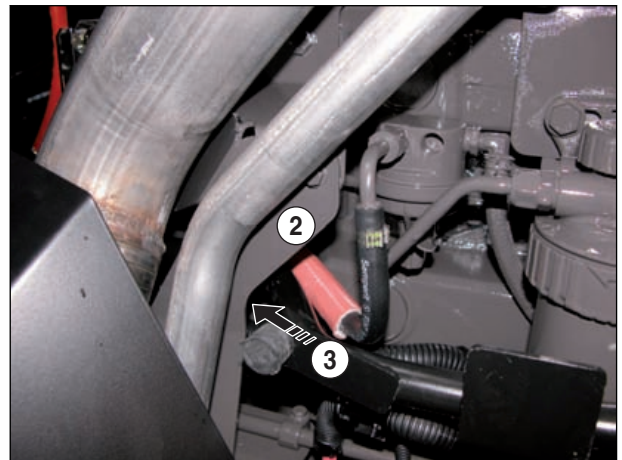

101msn02r

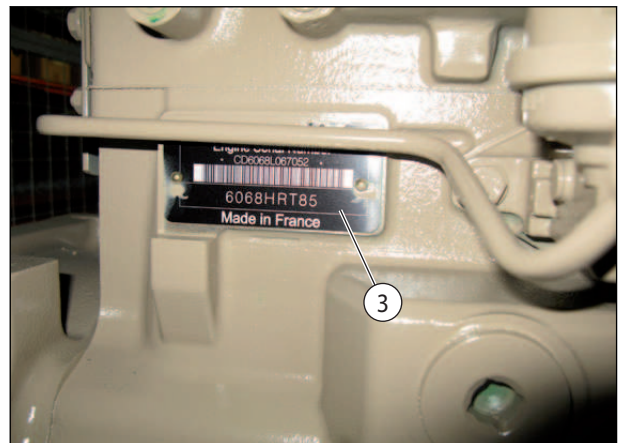

101msn03r

| | |
|--|---------------|
| | Type : |
|--|---------------|

| | |
|--|-----------------------|
| | Serial number: |
|--|-----------------------|

The emissions certification label (1) is located on the front right side of the cylinder head cover.

This label provides information on the engine (Manufacturer data).



101msn05m



- Unstable river banks.
- Steep slopes.

This list is not comprehensive. Evaluate permanently the risks taken in the work space.

Check nobody is standing in the risk zone between the tractor and tool.

Check nobody is standing next to the lifting zone.

Check nobody is present on the level of the wheels before using the tractor.

Before leaving the tractor, lower the front and rear tools to the ground.

As a general rule, always use equipment in good condition, suitable for the size of the tractor and the type of work.

The loads on the front and rear axle must not exceed the maximum acceptable loads specified in this user manual.

Extended exposure to a high noise level may cause hearing conditions, even deafness. To protect against noise, wear hearing protections, such as ear plugs.

Keep sufficient distance between high voltage power lines and the tractor.

Always check that nobody is inside the tool deployment zone.

Before using external controls, ensure nobody is present in the tool deployment zone, and that the engine is running at minimum speed.

6.1.7.2 Wheel track

6575

To limit the risk of tipping over, always use the maximum track width possible for the work to perform.

6.1.7.3 Hitching tools

5752

Carefully follow the instructions in the operator's manual for the machine mounted on the tractor, the towed machine or trailer, and do not use the tractor/machine assembly if the instructions have not been followed in full. If the tool is jammed or fails, apply the operating mode described in the tool's user manual to allow safe releasing.

To hitch or unhitch a tool, set the gear lever to neutral and apply the handbrake. Use a low gear for all tractor manoeuvres.

Sufficient front-end ballast must be used if the implement is heavy, to prevent the tractor rearing-up.

Towing bar: This is not intended as a trailer towing hitch and is not designed to carry vertical loads.

Use the safety equipment provided to hitch implements (towing jaw, towing stub, retaining pins, etc.).

When coupling or uncoupling tools, check that nobody is located between the tractor and the tool.

The front towing clevis must be used only to tow the tractor using a towing bar on solid ground. In no event should it be used to pull a swamped tool or tractor.

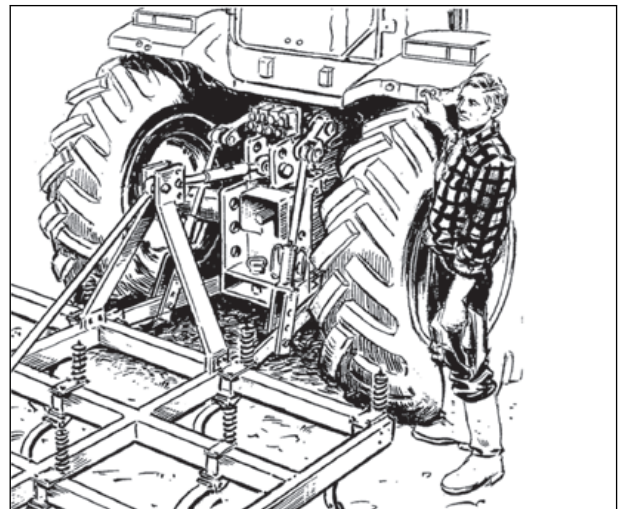

001hsn36

6.1.7.4 Driving

5754

Do not enter or leave the tractor when it is in motion.

Adapt speed to the conditions offered by the environment the tractor is used in.

On downhill routes, use the motor brake and maintain appropriate speed.

Consider the wheelbase and the inertia mass coupled tools.

Avoid risk of overturning.

Do not turn sharply when working on slopes. Maximum slope allowed while working: See chapter K.

During a break in work, even if only brief, stop the engine and apply the handbrake.

Before leaving the tractor, lower the front and rear tools to the ground.



6.2.7 SPEED LIMITS AND 13 YEAR AGE LIMIT FOR CHILDREN

5796

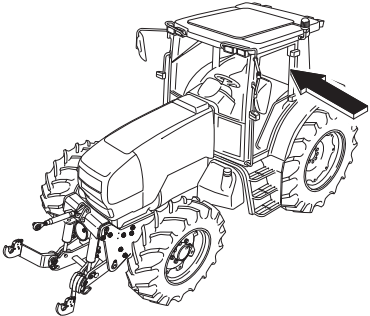
| Comments | Warning pictogram | Location |
|---|--|---|
| <p>Warning:</p> <ul style="list-style-type: none"> - This tractor must not be driven at speeds exceeding 30 km/h on public roads. - It is forbidden to transport a child under 13 years of age on farm machinery. <p>(Warning symbols according to the tractor's equipment and national regulations enforced)</p> | <div style="border: 1px solid black; padding: 5px;"> <p>WARNING</p> <p>This tractor MUST NOT be driven at speeds in excess of 30km/Hr on the public highway.</p> <p>WARNING</p> <p>It is prohibited for children under 13 years of age to ride on agricultural machines.</p> </div> |  |

6.2.8 Air conditioning

5797

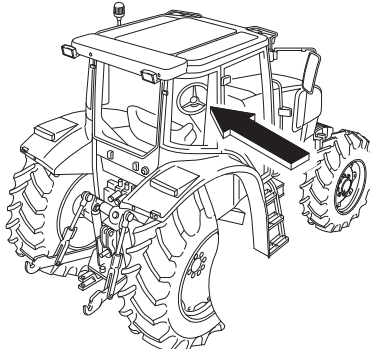
| Comments | Warning pictogram | Location |
|---|--|--|
| <p>Warning:</p> <ul style="list-style-type: none"> - This tractor's air conditioning is charged with freon R 134, which is a toxic gas when exposed to the open air. - Do not discharge the system without the appropriate equipment. <p>(Warning symbols according to the tractor's equipment and national regulations enforced)</p> | <div style="border: 1px solid black; padding: 5px;"> <p>WARNING</p> <p>The air conditioning system on this tractor is charged with R134A FREON which forms a poisonous gas when in contact with a naked flame.</p> <p>DO NOT VENT THE SYSTEM WITHOUT THE CORRECT EQUIPEMENT</p> </div> |  |

6.2.9 1 000 1/min power take-off

5798

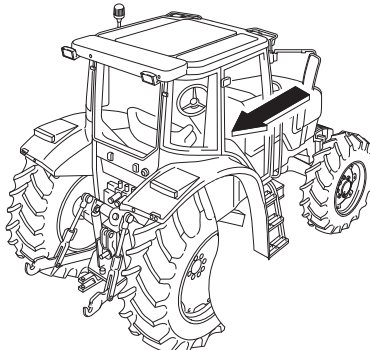
| Comments | Warning pictogram | Location |
|--|---|---|
| <p>Warning:</p> <ul style="list-style-type: none"> - Use the power take off at speed 1 000 1/min only if the attached tool is designed to be used at this speed. For further information, refer to the attached tool operator's manual. <p>(Warning symbols according to the tractor's equipment and national regulations enforced)</p> | <div style="border: 1px solid black; padding: 5px;"> <p>WARNING</p> <p>1000 REV/MIN P.T.O. MUST NOT BE USED UNLESS IMPLEMENT IS DESIGNED TO BE USED AT THIS SPEED (SEE OPERATORS HANDBOOK)</p> </div> |  |



2 LIGHTING, INDICATORS AND SAFETY

2.1 DESCRIPTION

4009



CAUTION

All interventions on xenon working lamps must be performed by the CLAAS certified network. Lamps should be replaced in pairs.

Important: The use of work lights on the road is strictly forbidden.

At the front

- 1 – Dipped headlights.
- 2 – Main beam lights.
- 3 – Direction indicators, hazard warning lights and side lights.
- 4 – Working lights.
- 5 – Dipped headlights or working lights (according to equipment fitted and destination).

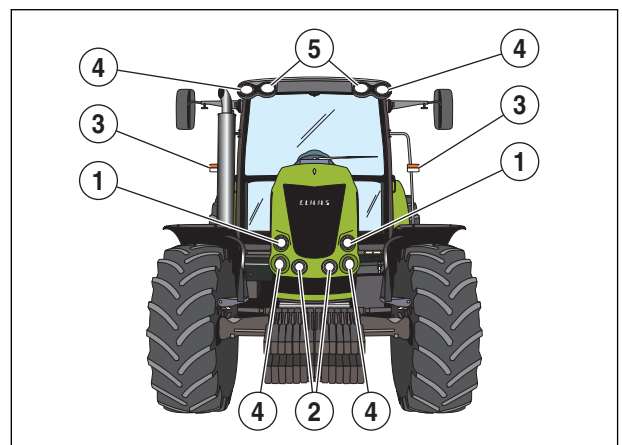

601msn31

At the rear

- 6 – Direction indicators and hazard warning lights.
- 7 – Brake lights and rear lights.
- 8 – Number plate lights.
- 9 – Working lights.
- 10 – Reflectors.
- 11 – Rotating beacons.
- 12 – Rear view mirrors.

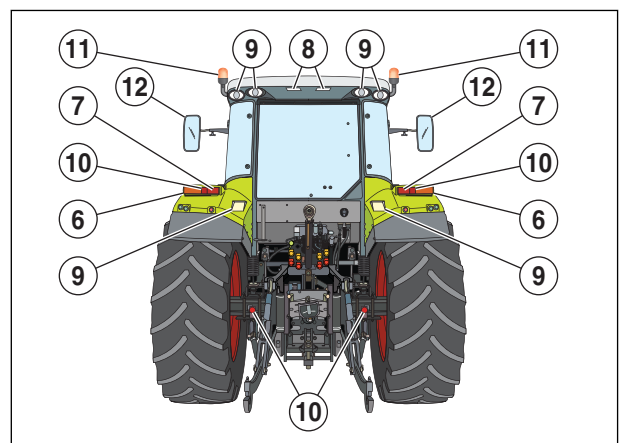

601msn0a

4.2 PASSENGER SEAT

5821



CAUTION

- The passenger seat may be used only when traveling on the road. Using the passenger seat is formally forbidden during work applications.
- The terms related with wearing the seatbelt during travel in public roads are defined by the country's traffic regulations. Apply the country's traffic regulations.
- When carrying a passenger, always drive with the doors closed and locked.

1 – Raise seat (1).



791msn02d

2 – Engage strut (1) in its support.

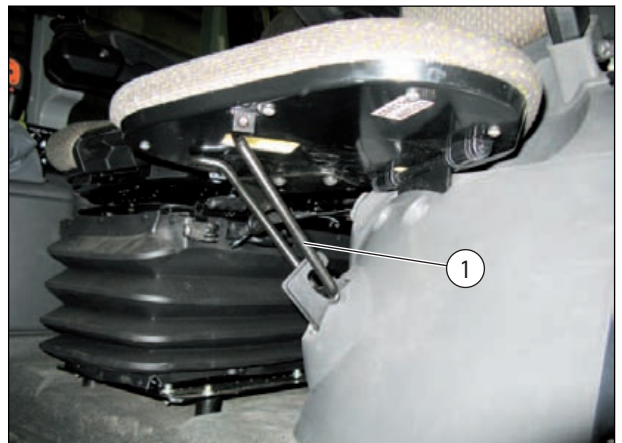

791msn03d

The passenger seat is fitted with a seat belt (1) ⁽¹⁾.



791msn04d

(1) According to the regulations in force in the country.



In case of a glass opening roof (2), the blind (3) is kept in position by the hook (4) and suction cups (5). Turn the handle (1) by a quarter turn to lock the sun roof closing.

Note: Move the blind while it is rolled up.

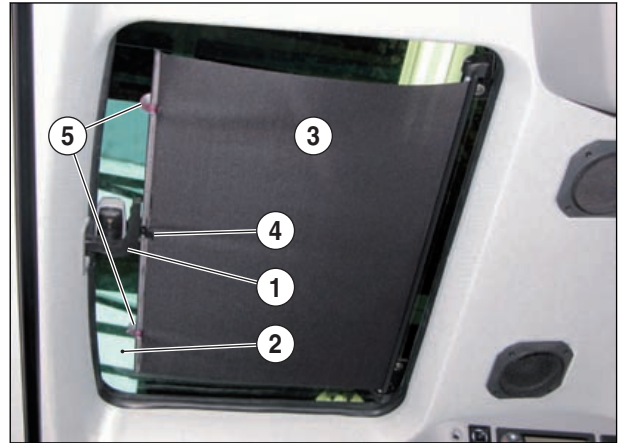

841msn36

Windscreen wash/wipe

Lever (2) for the front windscreen wiper has 3 positions:

- Position (A): OFF.
- Position (B): Intermittent wipe (every 10 seconds).
- Position (C): Continuous wipe.

The screen washer is controlled by the rotary knob (1) at the end of lever (2). Turn knob (1) clockwise until there is enough washer fluid on the screen.

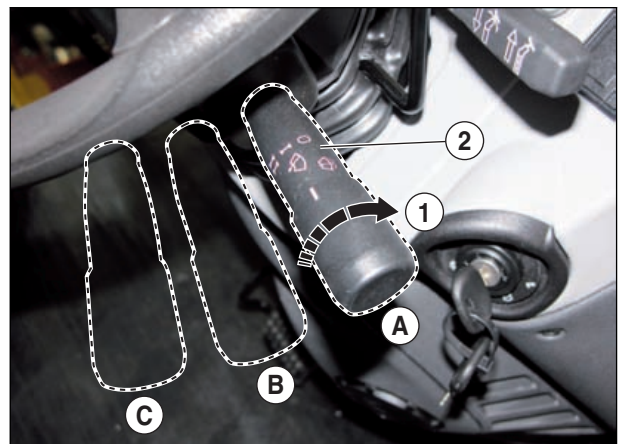

841msn34

Switch (1) for the rear screen wiper has 3 positions:

- Position (A): OFF.
- Position (B): Continuous wipe.
- Position (C): Screen washer.

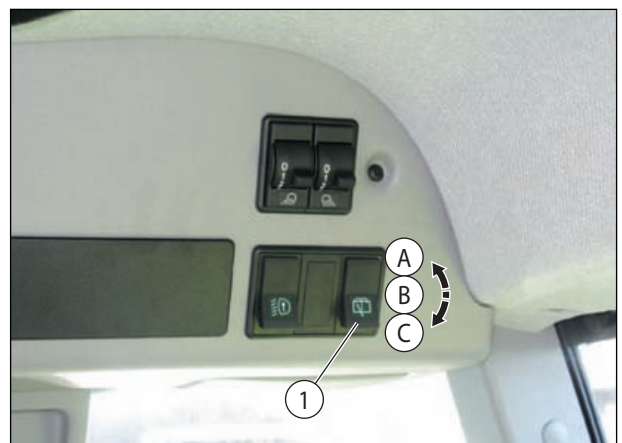

841msn47m



2 TRAILER/IMPLEMENT LIGHT SOCKET

4052



CAUTION

- Electric outlets available on CLAAS tractors comply with currently enforced standards. In no event should the terminals of power outlets be short-circuited. All modifications or interventions on the electric circuit of the trailer or tool must be performed by a specialist.
- The user is fully liable of electric equipment he connects and therefore he must check it is fully compliant. The liability of CLAAS may not be sought if these rules are not observed.
- If the socket is used, check that the implement lights are in good condition.

Trailer/implement light socket (1)

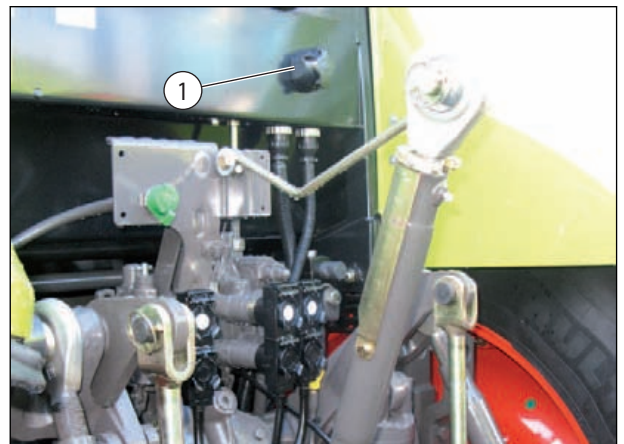

601msn0fr



601hsn68r



6.4 CAB TOP FUSE BOX

2854

The fuse box is located under the upper console to the right of the driver's seat. Remove the cover to access the fuses and relays.

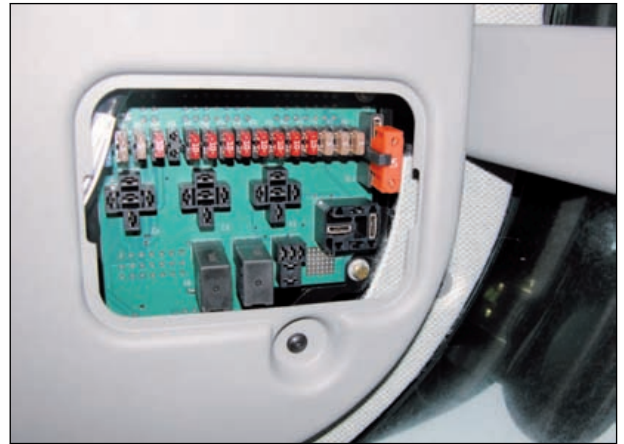

601msn0k

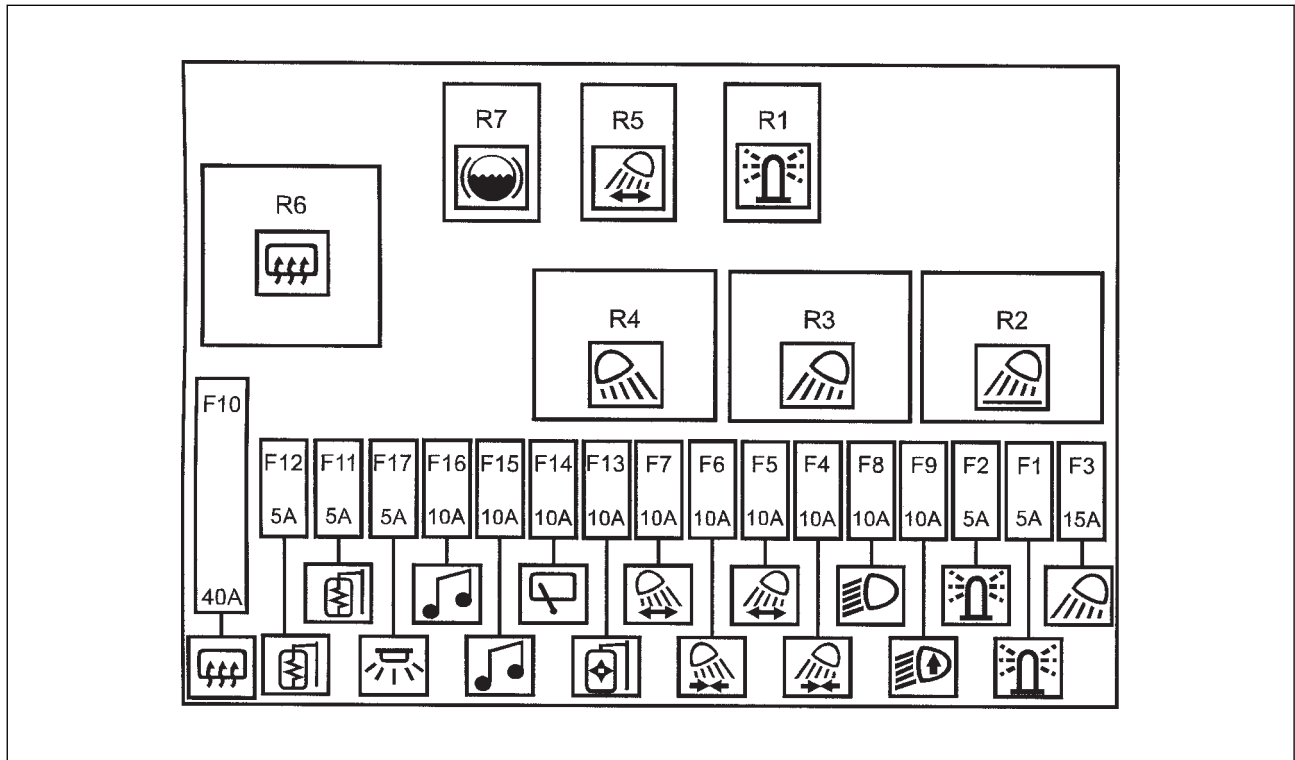

605hsn00

Relay allocation

| Relay | Designation |
|-------|--|
| R1 | Rotating beacons |
| R2 | Not used |
| R3 | Not used |
| R4 | Not used |
| R5 | Front work lights (top of cab, inside) |
| R6 | Not used |
| R7 | Not used |

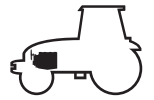

5 ENGINE CONTROL

5.1 STARTING THE ENGINE

5.1.1 Preliminary operations

4368



CAUTION

- Before starting the tractor, ensure that all preliminary operations described below have been carried out, and check that there is nobody around the tractor.
- Start the tractor from the driver seat only.
- Never short-circuit the battery.

Carry out the operations included in the 10 hour check (see chapter 'L'):

- Apply the handbrake.
- Place the reverser lever (1) in neutral.
- Check that the auxiliary spool valve control levers (1), (2), (3) and (4) are in neutral.
- Disengage the rear PTO with the control (5).
- Disengage the front PTO with the control (6).

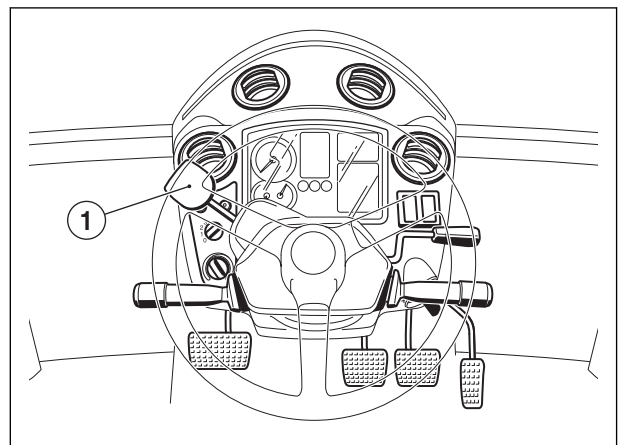

601msn0d

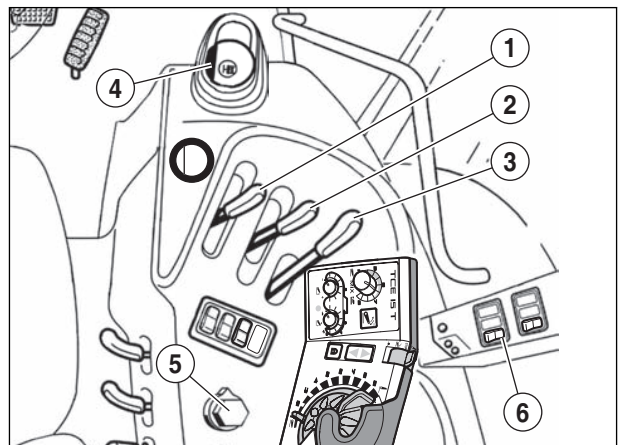

101msn03m

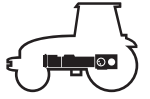

GEARBOX

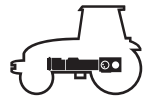

5 STARTING THE TRACTOR

5.1 CLUTCH

5.1.1 Recommendations

692



CAUTION

On a down-slope, always keep in gear and never declutch.

When the load being towed is heavy or for manoeuvres requiring a rapid reaction time (e.g. : on the road when setting off from a STOP sign), it is preferable to use the clutch pedal instead of the reverser lever to engage the clutch.

5.1.2 Clutch pedal

694

Press pedal (1) fully down to disengage. The pedal offers greater control when attaching a tool or during a difficult manoeuvre.

Important: With the exception of approach manoeuvres, we advise you to fully release the pedal when engaging the clutch (excessive clutch slip may cause serious wear).

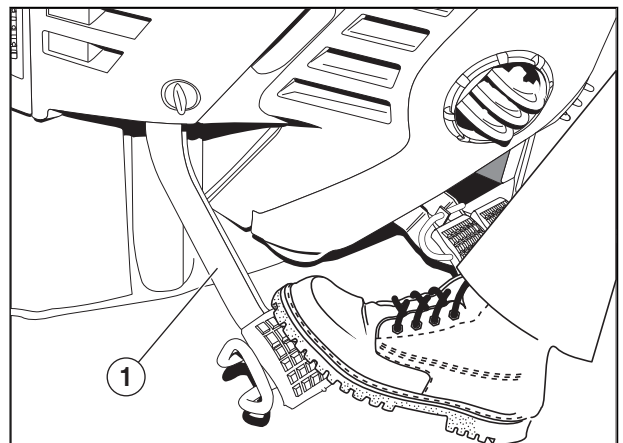

326hsn62

5.1.3 Reverser lever

2590

To release the clutch, raise the clutchless reverser lever (1) to position (A). The clutchless reverser is disengaged by holding the lever in this position; release the lever to engage it.

Note: This action on the reverser lever causes the symbol N to disappear. It triggers an alarm (light  on in the instrument panel and buzzer) if the lever remains in position (A) for over 2 seconds.



326msn51

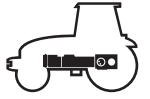

REAR AXLE

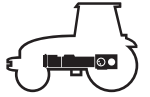

The pressure gauge (1) located on the right post indicates pressure of the air contained in the tank.

Service pressure: 8×10^5 Pa (8 bar)

Trailer braking is proportional to the force on the brake pedals (pedals coupled together).

Note: Connect the trailer hose coupling heads to release the trailer brakes. The trailer braking system is only operational once service pressure has been obtained.



371msn03

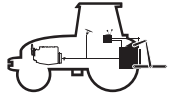

HYDRAULIC SYSTEMS

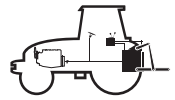

2.4 CONTROL LEVERS

6446



CAUTION

Always check that nobody is inside the tool deployment zone.

Auxiliary spool valves 1 and 2

| Lever positions | Control |
|-----------------------------|-----------------------------------|
| Position (A) | Supply: White pressure connectors |
| Position (B) | Neutral |
| Position (C) | Supply: Black pressure connectors |
| Position (D) ⁽¹⁾ | Floating |

(1) Spool valve 1: Optional feature.

- Supply is progressive between positions (A), (B) and (C) of the lever.
- The lever is maintained in positions (A) and (C) by a hydraulic locking.

Note: Unlocking by pressure⁽¹⁾: You do not have to keep holding the spool valve control to fully extend or withdraw a ram. This remains in up or down position, once the ram is fully extended, the increased pressure in the circuit returns the spool valve to neutral.

In the floating position (D), the pressure take-offs are connected to the reservoir, which enables the hitched implement to follow the undulations of the ground.



394msn28m

(1) Not all spool valves are fitted with this function.

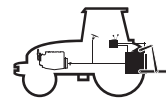

2 CONTROLS

2806

Internal controls

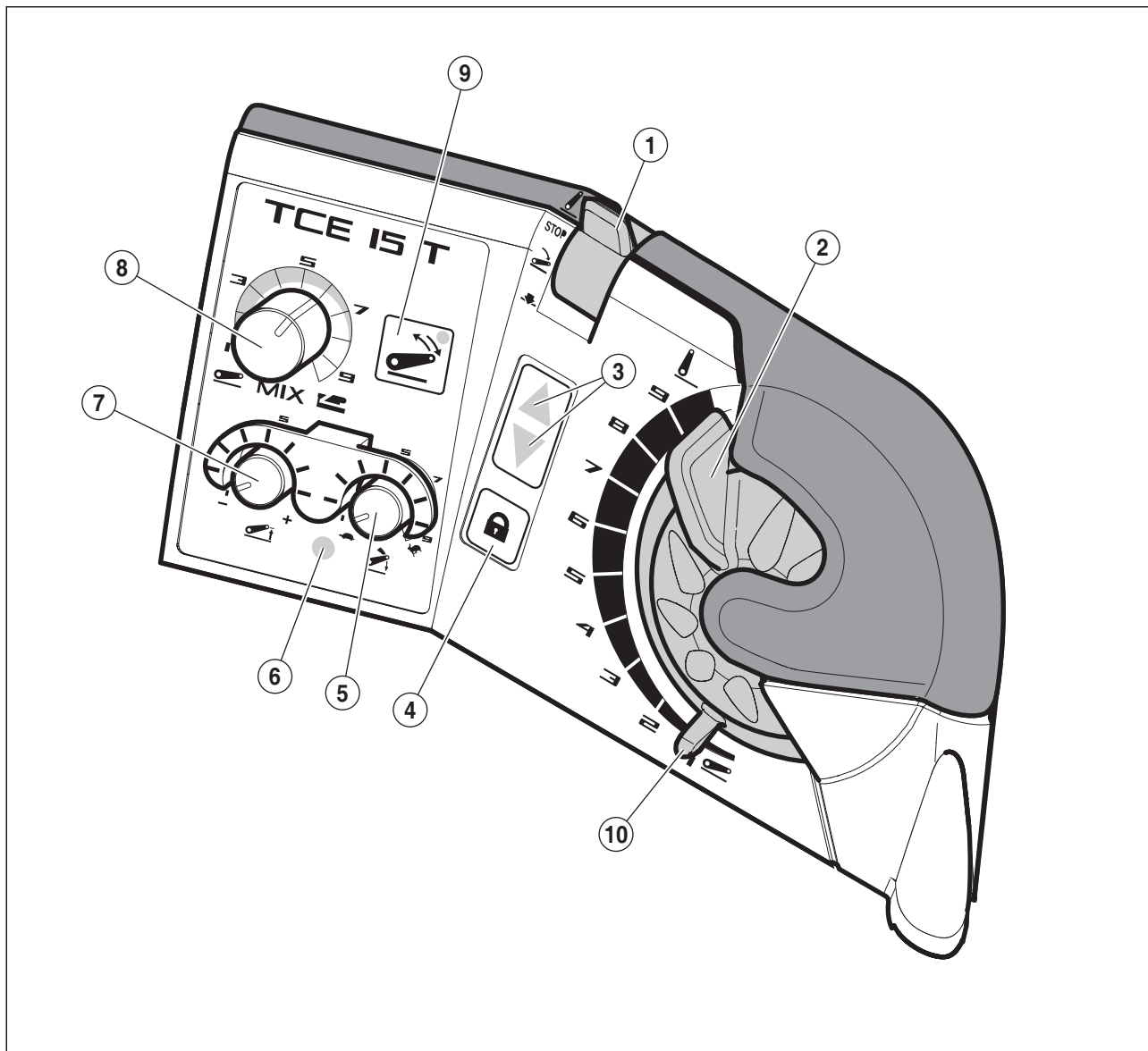

382hsn19

- | | |
|--|--|
| 1 – Mode selector. | 6 – Control box safety indicator light. |
| 2 – Setpoint knob (adjustment of work depth). | 7 – Upper limit adjuster. |
| 3 – Linkage motion indicator lights (up/down). | 8 – Stress/position ratio adjustment knob. |
| 4 – Transport lock button. | 9 – Button to activate transport damping mode. |
| 5 – Descent speed adjuster. | 10 – Mechanical stop identifying the "low limit" position. |

External controls

The external controls are located in the wings.

CLICK HERE TO **DOWNLOAD** THE COMPLETE MANUAL

- Thank you very much for reading the preview of the manual.
- You can download the complete manual from: www.heydownloads.com by clicking the link below



- Please note: If there is no response to CLICKING the link, please download this PDF first and then click on it.

CLICK HERE TO **DOWNLOAD** THE COMPLETE MANUAL

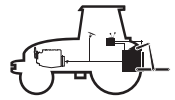

11 EXTERNAL CONTROLS

11.1 OPERATION

5874



CAUTION

- Immobilise the tractor.
- Do not stand in the risk area located between the tool and the tractor.
- Stand next to the tractor.
- Stay at a distance from the linkage area.
- External controls override the internal controls. The external controls on the left wing override the controls on the right wing.

Important: External controls override internal controls even when the transport safety is activated.

These two push buttons on each rear wing enable the arms to be raised (1) or lowered (2) when attaching or adjusting implements.

- UP button (1).
- DOWN button (2).

Press one of the buttons to obtain a movement in the direction required by about 10 cm. To obtain a more important movement, release the button and press again.

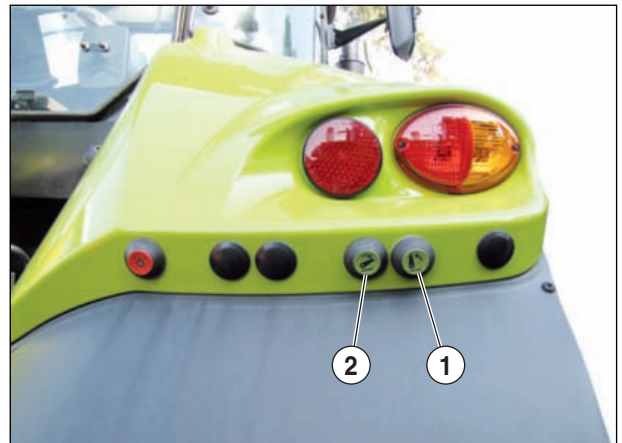

382msn04

11.2 OPERATION

4556



CAUTION

During hitching operations or when using the external linkage control, the operator must remain outside the hitch frame.

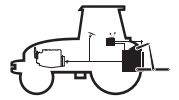

7 POWER TAKE-OFF END FITTING

4505



CAUTION

During removal / refitting of the output shaft, the engine must be stopped and that no implement is to be attached to the rear linkage.

To remove the PTO end fitting (1) proceed as follows:

- Place a wrench (3) on one of the 6 screws (2).
- Turn the PTO shaft to set the end of the wrench (3) against the right-hand side of the hitching ladder.
- Unscrew the 6 screws (2) using a wrench (4) to remove the PTO tip (1).

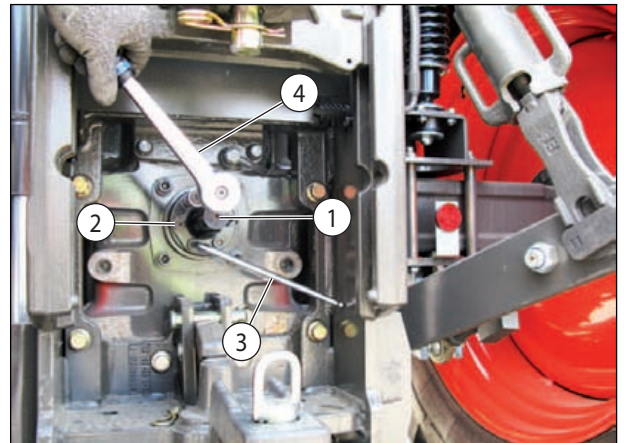

343msn01d

To fit the PTO tip (1), proceed as follows:

- Reposition the desired end fitting (6, 8 or 21 splines) using the centring studs.
- Lightly coat the threads of screws (2) with Loctite 241.
- Tighten the 6 screws (2) with a torque wrench (5) at the tightening torque recommended: 84 ± 12 Nm.

Important: To lock the PTO shaft, apply a procedure similar to that used for removal: Set the wrench (3) against the left-hand side of the hitching ladder.

CLAAS is not liable for an accident caused by the non respect of the above fitting instructions.

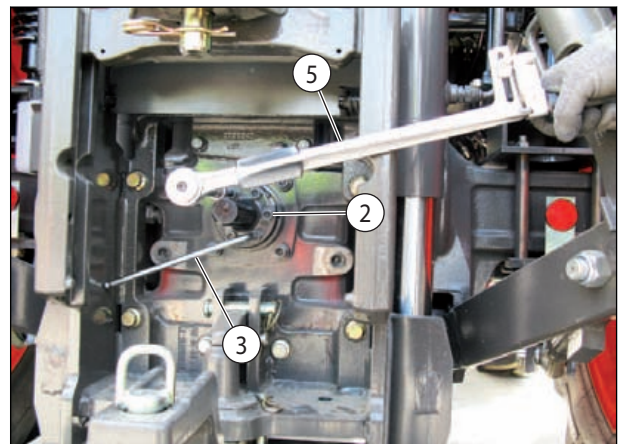

343msn02d

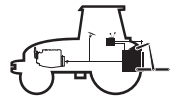

4 UPPER LINK

4504



CAUTION

- Check that the uncovered thread lengths (A) are equal (Maximum gap: 5 mm).
 - The center distance (B) of the upper tie rod must not exceed 770 mm.
 - When adjustment is finished, fold the adjusting handle (1) onto the central body and fit the link to the implement's arm.
-
- Hold the upper end of the rod.
 - Lift the adjusting handle (1) and turn the central body to adjust the length of the link.

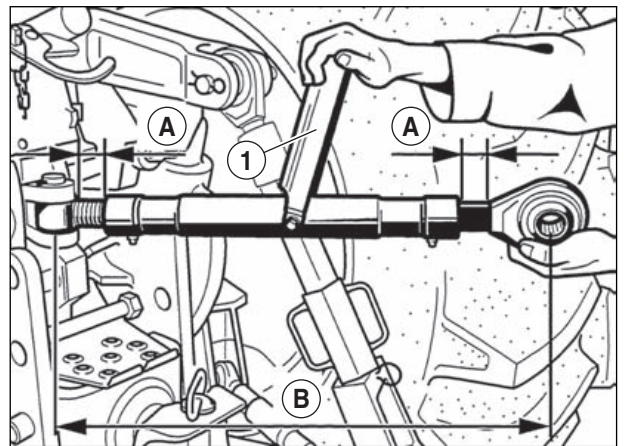

541hsn14



H - FRONT EQUIPMENT





FRONT LINKAGE



6.3 HITCHING AND UNHITCHING THE TOOL

5987



CAUTION

- Check nobody is standing in the risk zone between the tractor and tool. Before entering or having someone entering the hazardous zone, immobilize the tractor and tool to prevent any untimely movement.
- Connect the hydraulic, electric and pneumatic fittings properly between the tractor and the hitched tool.
- Comply with the maximum load capacity of the tractor's hitches.
- Never perform any welding, cutting, drilling, sanding work on hitching devices. Replace any worn or damaged parts.
- After any hitching operation, check that the automatic hooks (4) are positively locked.
- Check that the ball joint diameters fit the implement's hitch pins. If necessary fit spacers (3).

Important: Place the corresponding ball joints (1) or (2) on the implement tow axles.

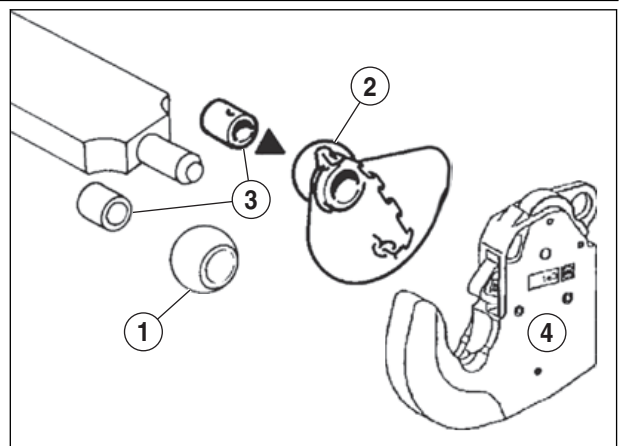

544msn.30

Linkage of the tool



CAUTION

To prevent the tool from tipping during hitching operations, you can fasten the upper tie rods before the lower tie rods (For example: Case of tools in unstable position).

- Offer up the tractor to the implement.
- Raise the front lifting arms until locking the automatic hooks (4).
- Lower the front lifting arms.
- Place the upper tie rod hook onto the tool's hitch axis.
- Connect the hydraulic hoses, the electric cables and the drive shaft linking the implement to the tractor.



FRONT LOADER

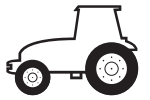

- Place the front or rear axle on stands.
- Remove the front or rear wheels.
- Position the wheel discs and rims to obtain the desired working track (see table of tracks).
- Tighten the screws and nuts of the wheel disc on the rim.
- Tighten the wheel cover nuts on the wheel shaft.

For torque settings, refer to chapter 'L'.

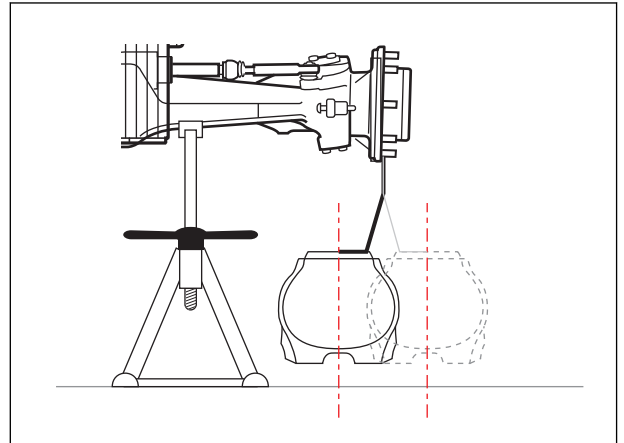

451HSN07

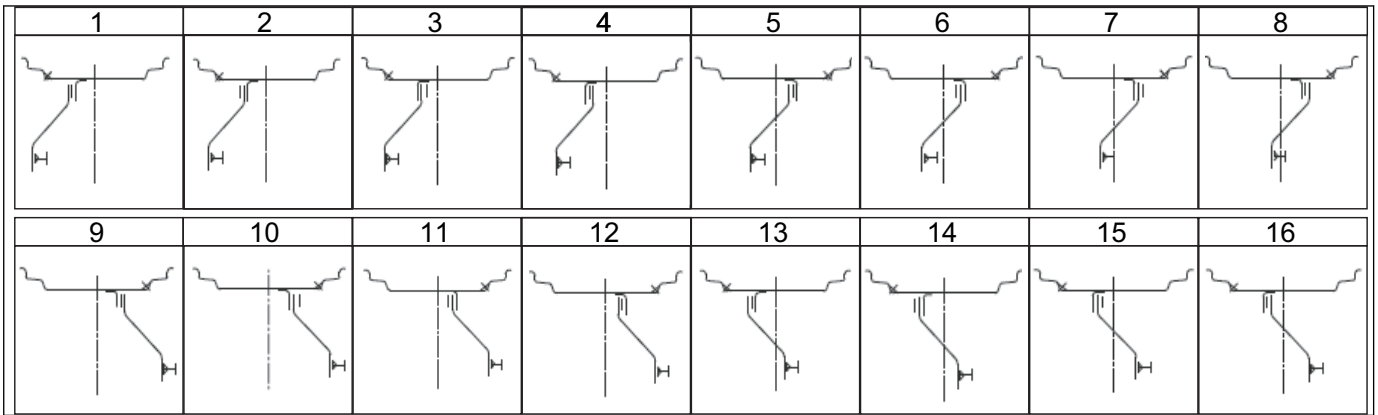
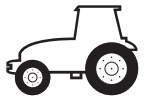

511hsn09m

| Type of rear axle GPA 22+ | | | | | | | | | | | | | | | | | |
|---|----------|---|---|---|---|-------|-------|-------|-------|-------|-------|-------|-------|--------------|-------|-------|-------|
| ARION 620C | | | | | | | | | | | | | | | | | |
| Rims with connector bars or welded circle | | | | | | | | | | | | | | | | | |
| Rear tracks (mm) | | | | | | | | | | | | | | | | | |
| Tyres | Type | 1 | 2 | 3 | 4 | 5 | 6 | 7 | 8 | 9 | 10 | 11 | 12 | 13 | 14 | 15 | 16 |
| 18.4R38 | DWW 15 L | | | | | 1 739 | 1 708 | 1 669 | 1 638 | 2 139 | 2 108 | 2 069 | 2 038 | 1 835 (1) | 1 866 | 1 905 | 1 935 |
| 460/85R38 | DWW 15 L | | | | | 1 739 | 1 708 | 1 669 | 1 638 | 2 139 | 2 108 | 2 069 | 2 038 | 1 835 (1) | 1 866 | 1 905 | 1 935 |
| 520/70R38 | DWW 18 L | | | | | 1 739 | | | | 2 139 | 2 108 | 2 069 | 2 038 | 1 835 (1) | 1 866 | 1 905 | 1 935 |
| 600/65R38 | DWW 18 L | | | | | 1 739 | | | | 2 139 | 2 108 | 2 069 | 2 038 | 1 835 (1) | 1 866 | 1 905 | 1 935 |
| 480/80R38 | DWW 18 L | | | | | 1 739 | 1 708 | 1 669 | 1 638 | 2 139 | 2 108 | 2 069 | 2 038 | 1 835 (1) | 1 866 | 1 905 | 1 935 |
| 20.8R38 | DWW 18 L | | | | | 1 739 | 1 708 | 1 669 | | 2 139 | 2 108 | 2 069 | 2 038 | 1 835 (1) | 1 866 | 1 905 | 1 935 |
| 520/85R38 | DWW 18 L | | | | | 1 739 | 1 708 | 1 669 | | 2 139 | 2 108 | 2 069 | 2 038 | 1 835 (1) | 1 866 | 1 905 | 1 935 |
| 580/70R38 | DWW 18 L | | | | | 1 739 | 1 708 | | | 2 139 | 2 108 | 2 069 | 2 038 | 1 835 (1) | 1 866 | 1 905 | 1 935 |
| 650/65R38 | DWW 20 B | | | | | | | | | 2 139 | 2 108 | 2 069 | 2 038 | 1 835 (1) | 1 866 | 1 905 | 1 935 |
| 540/80R38 | DWW 18 L | | | | | 1 739 | 1 708 | 1 669 | 1 638 | 2 139 | 2 108 | 2 069 | 2 038 | 1 835 (1) | 1 866 | 1 905 | 1 935 |

(1) Track on delivery



2 WEIGHT

4679

| Weight | | ARION 610C | ARION 620C | ARION 630C |
|---|-------------------------------------|-------------------|-------------------|-------------------|
| Front tyres (original equipment) | | 13,6R28 | 14,8R28 | 14,8R28 |
| Rear tyres (original equipment) | | 16,9R38 | 18,4R38 | 18,4R38 |
| Dry weight: – Without weight block. – Without removable weights. – All full. – With driver. | Total weight (kg) | 5 502 | 5 596 | 5 815 |
| | Front/rear weight distribution (kg) | 2 195 / 3 307 | 2 227 / 3 369 | 2 249 / 3 566 |
| | Anti-pitching moment (m.kg) | 6 193 | 6 284 | 6 344 |
| | | | | |
| Weight with ballasting: – With weight carriers / 100 kg. – With removable weights / 704 kg. – All full. – With driver. | Total weight (kg) | 6 306 | 6 400 | 6 618 |
| | Front/rear weight distribution (kg) | 3 255 / 3 051 | 3 287 / 3 113 | 3 309 / 3 309 |
| | Anti-pitching moment(m.kg) | 9 180 | 9 270 | 9 330 |
| | | | | |
| Weight with front linkage: – All full. – With driver. | Total weight (kg) | 5 927 | 6021 | 6 164 |
| | Front/rear weight distribution (kg) | 2 575 / 3 352 | 2 607 / 3 414 | 2 607 / 3 557 |
| | Anti-pitching moment (m.kg) | 7 261 | 7 351 | 7 351 |
| | | | | |
| Weight with front linkage: – With weight on front linkage / 600 kg. – All full. – With driver. | Total weight (kg) | 6 527 | 6 621 | 6 764 |
| | Front/rear weight distribution (kg) | 3 441 / 3 086 | 3 473 / 3 148 | 3 473 / 3 271 |
| | Anti-pitching moment (m.kg) | 9 702 | 9 793 | 9 793 |
| | | | | |



7.2 VIBRATION LEVEL

4771

ARION 600C tractors are classified category A. Category A consolidates all tractors with a determined class of vibration due to similar construction specifications:

- Tractors with 2 axles.
- Tractors with a rear axle without suspension.

Tractors category A are divided into 3 classes:

- Class I: Tractors with an empty weight below 3 600 kg.
- Class II: Tractors with an empty weight between 3 600 kg and 6 500 kg.
- Class III: Tractor with an empty weight above 6 500 kg.

Note: Category B consolidates all tractors not meeting the criteria of category A.

The following table lists the results of measurements performed on the test bench on seats as per the 78/764 directive. The a_{wS}^* value is the corrected value of the effective acceleration value weighted with vibratory movement.

| Make of seat | Model | Suspension | Class II | | Class III | |
|--------------|------------|-----------------------|---------------------------------------|---------------------------------------|---------------------------------------|---------------------------------------|
| | | | $a_{wS}^* (1)$ (m/s ²) | $a_{wS}^* (1)$ (m/s ²) | $a_{wS}^* (1)$ (m/s ²) | $a_{wS}^* (1)$ (m/s ²) |
| Grammer | MSG85/731 | Mechanical suspension | 1,15 | 0,85 | 1,22 | 0,85 |
| Grammer | MSG95G/731 | Pneumatic suspension | 1,24 | 1,10 | 1,20 | 1,10 |



3 TRANSPORT

4664

To transport a tractor, use a truck fitted with a platform.

Important: An extra long load is mandatory for an overall width exceeding 2,55 m.

- Use a loading platform or loading ramps to load the tractor onto the platform.
- Once the tractor is in place on the platform:
 - Stop the engine.
 - Apply the handbrake.
 - Chock the wheels.
 - Switch off the battery with the battery isolation switch.

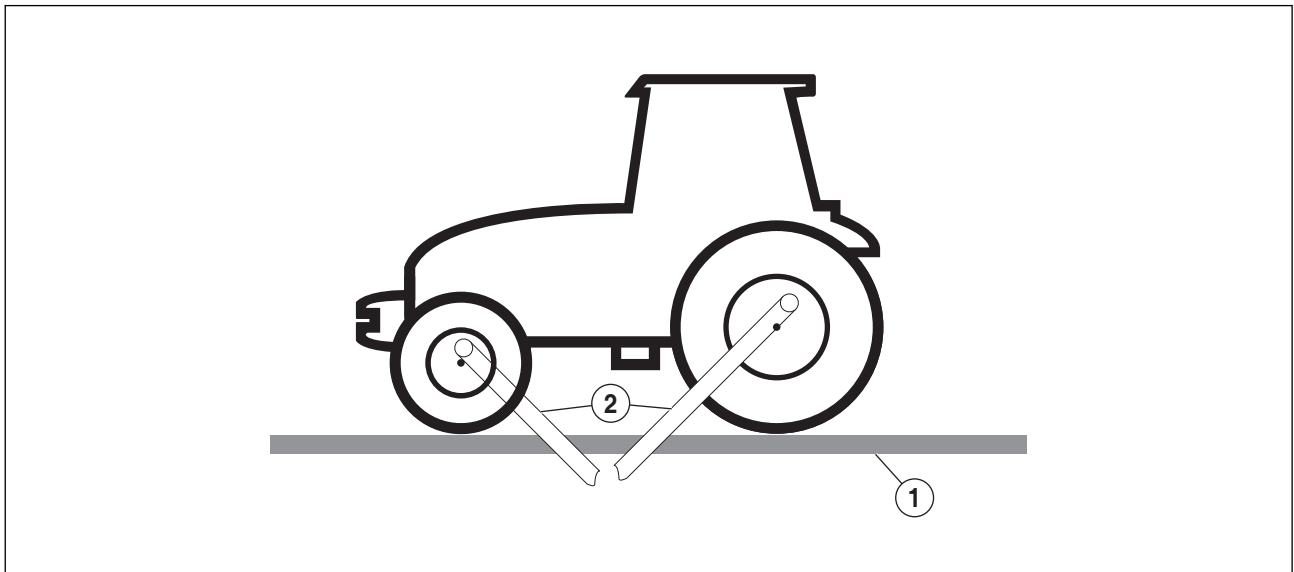

560msn01

1 – Platform

2 – Straps

- Stow the tractor properly onto the platform with straps.
- Check no non stowed object is located on the platform or the tractor to avoid any projection during transport.
- Remove the ignition key.

Important: Close all casements and lock the doors.



| <i>Frequency</i> | <i>Operation n°</i> | <i>Maintenance operations</i> | <i>Lubrication</i> | | | |
|---|---------------------|-------------------------------|--------------------|--|--|--|
| | | | <i>Cleaning</i> | | | |
| | | | <i>Check</i> | | | |
| | | | <i>Replace</i> | | | |
| Every 2 000 hours or every 2 years | 57 | Brake system fluid | X | | | |
| Every 3 years ⁽³⁾ | 58 | Cab shock absorbers | X | | | |
| Every 4 500 hours | 59 | Safety cartridge | X | | | |
| Every 4 500 hours or every 5 years ⁽³⁾ | 60 | Vibration damper | X | | | |

(1) Or every month.

(2) If fuel sulphur content exceeds 0,2 % replacement frequency changes to 300 heures.

(3) Whichever comes first.



9.2.14 Operation n° 14

4596

Check: Hydraulic fluid level



CAUTION

- Failure to comply with instructions for checking hydraulic fluid level may result in loss of safety functions (steering, etc.).
- To top up the oil, observe the specifications in terms of oil grade. See chapter K.

- Position the tractor on a flat horizontal surface.
- For suspended front axles, place the axle in the mid position.
- Fully lower the rear lifting.
- Place the front linkage in the high position.
- The engine must have been stopped for at least 5 minutes.
- Check the fluid level with dipstick (1):

The fluid is topped up via the cap (2).

Important: The fluid level must never fall below the lower mark (I). If hydraulic tools which draw a large quantity of oil from the transmission are used (e.g. hydraulic motors or large capacity rams) top the oil up to near the upper mark (IV). Failure to carry out these instructions can in some circumstances cause considerable damage to the power transmission.

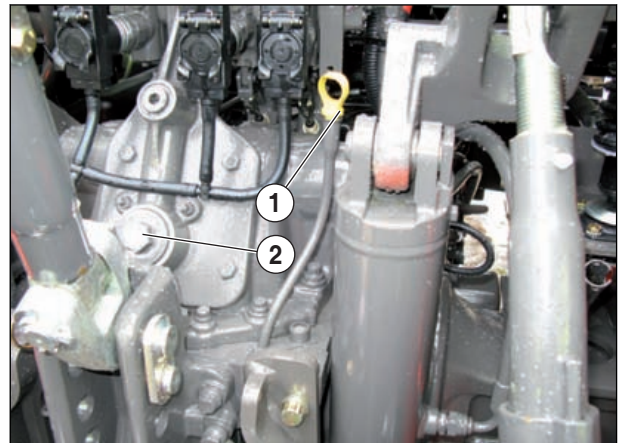

343msn00m



9.2.28 Operation n° 28

621

Check: Front axle final drive oil level



CAUTION

Unscrew the plug (1) in the top position to prevent projection due to excessive pressure.

- Position the tractor on a flat horizontal surface.
- Position the inscription "OIL LEVEL" horizontally.
- Apply the handbrake.
- Unscrew the plug (1).
- The oil level should be just at the bottom of the aperture; Top up if required.

Important: To top up the oil, observe the specifications in terms of oil grade. See chapter K.

- Tighten the filler plug (1):
 - Tightening torque: 70 Nm



511hsn22

9.2.29 Operation n° 29

6346

Check: Tightening the wheel disc nuts on the rims

- Check the tightness of the wheel rim nuts:
 - Rims with spacers (3): 280 ± 30 Nm



511hsn04m



Diameter of the hitch spindle

- If the diameter of the spindle (5) is less:
 - Than 29 mm for an original diameter of 31 mm.
 - Than 35 mm for an original diameter of 38 mm.

Replace any defective components.

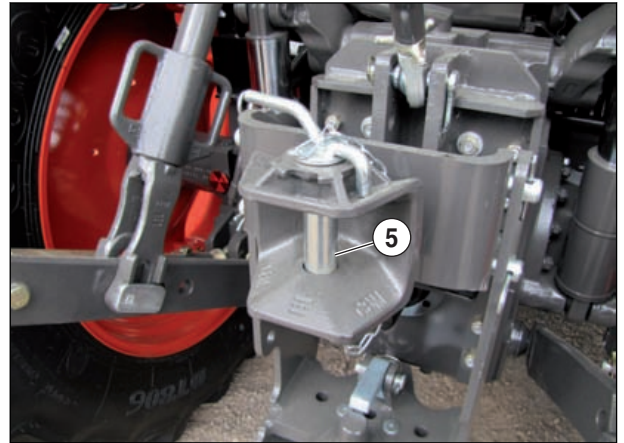

545bsn04I

Locking spindles

- If the diameter of the locking spindles (6) is 1 mm less than its original diameter.

Replace any defective components.

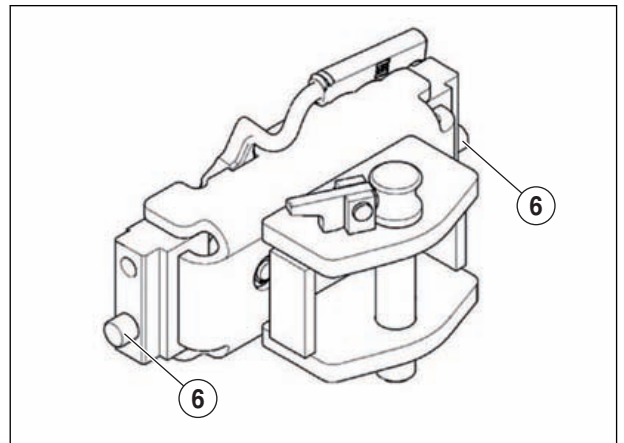

545bsn05I

9.2.40 Operation n° 40

6409

Lubrication: Clevis

Automatic coupling. Rotating hitch fork:

- Grease the greaser (1).
- Grease the locking spindles (2).

Clevis Cuna C and D2:

- Grease the locking spindles (2).

Note: The hitch clevis used on a spindle hitch ladder is maintenance-free.

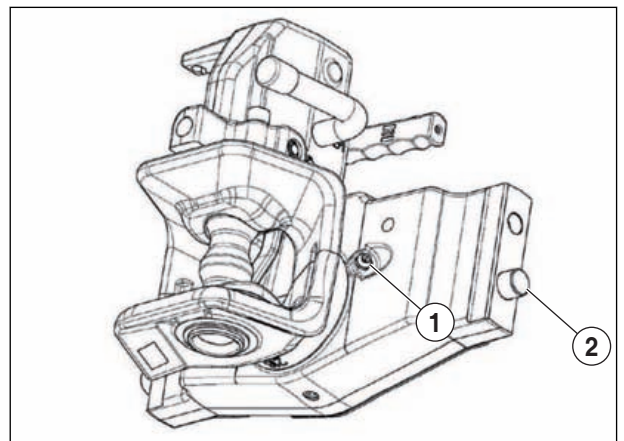

545bsn03I



- Release the belt tightness by means of a key located on the automatic belt tightener (1).
- Remove the old belt from the pulleys.



101msn02m

- Slip the new belt between fan (2) and the cooling nozzle (3).
- Assemble the new belt taking care to follow the correct path over the different pulleys (see "Positioning the belt").
- Tighten the belt again by gradually loosening the key located on the automatic belt tightener (1). Remove the wrench.

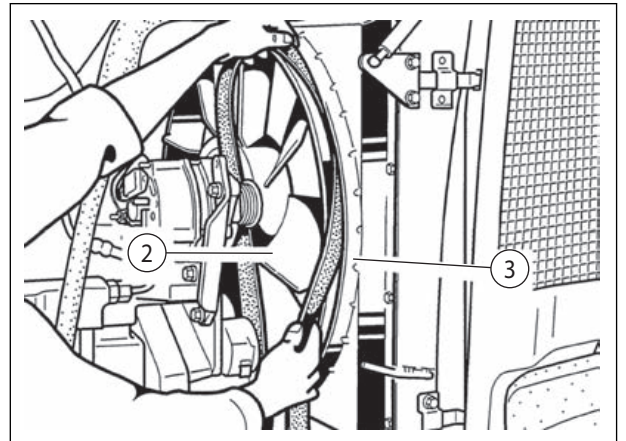

253msn03d

Position of belt

- 1- Alternator.
- 2- Tensioner roller.
- 3- Water pump.
- 4- Crankshaft.
- 5- Pneumatic brake compressor.
- 6- Return roller.
- 7- Fan.
- 8- Air conditioning compressor.

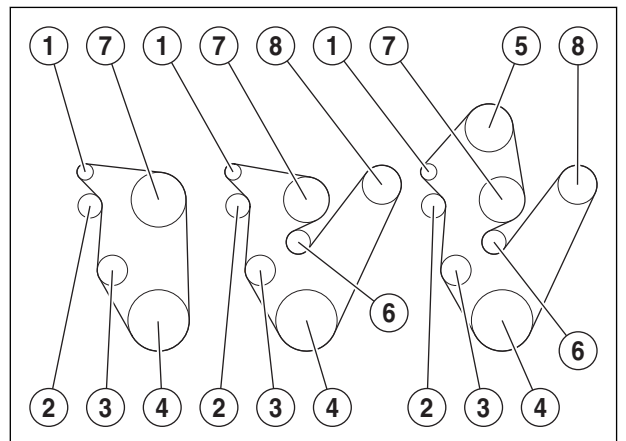

253msn01

9.2.57 Operation n° 57

Replace: Brake system fluid (depending on equipment fit)

This operation must be performed by a CLAAS approved workshop.

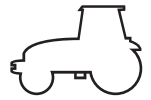

1.4 MANDATORY INSPECTIONS

1.4.1 Mandatory service after the first 100 hours

5847

After an operating time of 100 hours, you must contact your CLAAS approved workshop and make an appointment for the first technical visit.

Engine

- Drain and replace engine oil.
- Replace filter cartridge.
- Tighten manifolds.
- Tighten air filter hose clamps.
- Check that dry air filter clogging warning light is operating.
- Check pipes and connections in injection circuit.
- Remove deposits from fuel filter bowl.
- Check for leaks in cooling system.
- Tighten hose clamps on the heating and cooling circuits.
- Check coolant level in the radiator.
- Replacing the diesel strainer.

HYDRAULIC SYSTEM

- Check for leaks in all circuits.
- Replacement of hydraulic filters.

Hydrostatic steering

- Check for correct operation.

Front drive train - Front axle

- Grease via nipples.
- Check tightness of connecting screws (engine - front drive train support, steering gear, front weights).
- Tighten wheel nuts.
- Drain and replace oil in final drives.
- Drain and replace oil in differential housing.
- Check for leaks.
- Check and adjust alignment.
- Tighten the base weight.
- Front weight attachment bolts.

Transmission- Lift

- Check for leaks.
- Check oil level.
- Checking - adjustments:
 - Forward clutch.
 - Foot brake.
 - Parking brake.
- Check brake fluid level.
- Check braking efficiency.

Wheels and tyres

- Check tyre condition, inflation pressure.
- Check the tightening of wheel spider nuts in hub and rim.

CLICK HERE TO **DOWNLOAD** THE COMPLETE MANUAL

- Thank you very much for reading the preview of the manual.
- You can download the complete manual from: www.heydownloads.com by clicking the link below



- Please note: If there is no response to CLICKING the link, please download this PDF first and then click on it.

CLICK HERE TO **DOWNLOAD** THE COMPLETE MANUAL