

CLAAS



**ARION 640-630-620-610 C.I.S.
ARION 540-530-520-510 C.I.S.**

Operator's manual

SERVICE & PARTS

CLICK HERE TO **DOWNLOAD** THE COMPLETE MANUAL

- Thank you very much for reading the preview of the manual.
- You can download the complete manual from: www.heydownloads.com by clicking the link below



- Please note: If there is no response to CLICKING the link, please download this PDF first and then click on it.

CLICK HERE TO **DOWNLOAD** THE COMPLETE MANUAL

5	ENGINE CONTROL	D. 12
5.1	STARTING THE ENGINE	D. 12
5.2	USING THE ACCELERATOR PEDAL AND LEVER	D. 16
5.3	STOPPING THE ENGINE	D. 18
6	CLAAS POWER MANAGEMENT	D. 19
7	FUEL	D. 20
7.1	RECOMMENDATIONS	D. 20
7.2	BLEEDING AIR FROM THE INJECTION SYSTEM	D. 21

E - TRANSMISSION

GEARBOX

1	CHARACTERISTICS	E. 4
2	FORWARD SPEEDS	E. 5
3	DISPLAY	E. 18
3.1	TRANSMISSION DISPLAY	E. 18
3.2	INSTRUMENT PANEL	E. 18
4	SAFETY	E. 20
4.1	REVERSER NEUTRAL	E. 20
4.2	TRANSMISSION NEUTRAL	E. 22
4.3	PROTECTION OF MECHANICAL PARTS	E. 23
5	STARTING THE TRACTOR	E. 25
5.1	TRANSMISSION DISPLAY	E. 25
5.2	CLUTCH	E. 25
5.3	SELECTION OF MOVEMENT DIRECTION	E. 26
5.4	REVERSER PROGRESSIVITY ADJUSTMENT	E. 27
5.5	COUPLING/DECOUPLING FORWARD/REVERSE GEARS	E. 29
6	MANUAL GEAR CHANGES	E. 31
6.1	START RATIO	E. 31
6.2	WORK MODE	E. 32
6.3	ROAD MODE	E. 33
7	AUTOMATIC GEAR CHANGES	E. 35
7.1	SKIP SHIFT	E. 35
7.2	AUTOMATIC SPEED ADAPTATION (SPEED MATCHING)	E. 35
7.3	MANOEUVRING GEAR	E. 36
7.4	HEXACTIV	E. 38
8	RATIO MANAGEMENT	E. 44
8.1	OPERATION	E. 44
8.2	TRANSMISSION DISPLAY	E. 44



The tractor's identification number (B) is composed of the regulation type (1) and serial number (2) of the tractor (the example given opposite is completely fictitious).

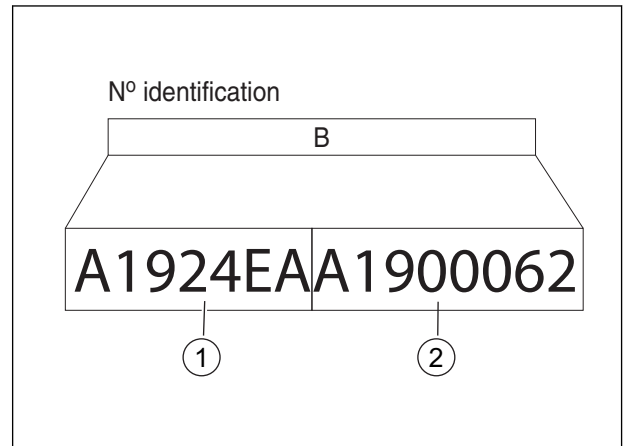

841hsn06m

Tractor regulation type

The regulation type (1) is broken down in the following manner:

Type of tractor	Engine power code	Number of drive wheels	Cabin type	Maximum tractor speed
A18	0: ARION 510 1: ARION 520 2: ARION 530 3: ARION 540	4	E: Suspended cabin	A: 40 km/h C: 50 km/h
A19	0: ARION 610 1: ARION 620 2: ARION 630 3: ARION 640			

Tractor serial number

The tractor's serial number (2) is composed of the tractor type "A18/A19" followed by a 5 digit number.



- Stand in a well vented location.
- Wipe immediately any spilled combustible.
- To prevent any risk of fire, remove any built-up grease or dirt.
- Before filling the tank, always carefully clean around the fuel cap to remove any pieces of straw, twigs, etc. which could help start and then propagate a fire.

Important: When transporting fuel, use containers intended for this purpose. Your container must only be used for this purpose.

6.1.5.5 Coolant

5755

- Do not work on the cooling system when the engine is hot.
- Engine stopped, remove the drain plug only when it is cool enough to be turned by hand. Start by turning the plug at the first notch to eliminate pressure, then remove it completely.
- Fluid leaking from the cooling circuit may cause severe burns. Wear gloves and goggles.
- In case of projection of coolant on your skin or in your eyes, thoroughly rinse with water immediately, and call a doctor.

6.1.6 Road use - Use for transport

5751

In all circumstances, apply the legislation on driving wheel-fitted farming tractors applicable in your country.

Never exceed the maximum transportation speed of the machine.

If in doubt, consult the police or insurance companies.

- Never exceed the load permitted tractor (See chapter K).
- Never exceed the allowed masses of the tractor (See chapter K).

Before any movement:

- Check effectiveness of the tractor brakes.
- Check the effectiveness of the rolling tools if they are fitted with a braking system.

Before each trip, check the braking.

When driving on the public road the doors must be closed and latched.

Before driving the tractor on the road, check that the rear-view mirrors are clean and correctly adjusted.

Make sure that the equipment is hitched correctly and safely locked in position.

Whenever possible, avoid using busy roads.

When transporting equipment on a public road, use the warning device required by the highway code. All indicators must be clean and in working order.

The working lights must not be lit.

Brake pedals must be coupled together.

Do not use the hand accelerator when the tractor is running on the road.

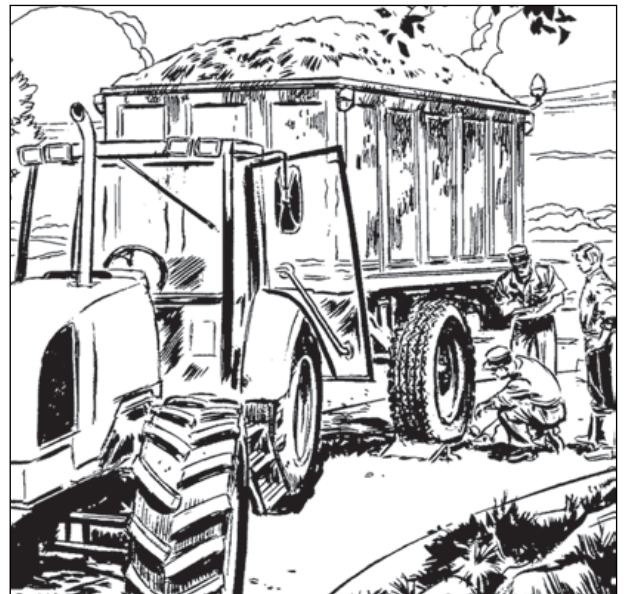

001hsn34



6.2 SAFETY STICKERS WITH WARNING PICTOGRAMS

6.2.1 Recommendations

5768

Replace any damaged, missing or illegible safety sticker. Apply a new sticker to any new part replacing a part which had one.

Spare stickers are available from your CLAAS approved workshop.

Note: According to the law enforced in your country, the stickers described below may not be present on the tractor.

6.2.2 Placing the gear box in neutral

5792

Comments	Warning pictogram	Location
<p>Warning:</p> <ul style="list-style-type: none"> Follow the safety instructions when leaving the driver's seat (refer to the operator's manual for placing the gear box in neutral). <p>(Warning symbols according to the tractor's equipment and national regulations enforced)</p>		

6.2.3 Front linkage

6080



Comments	Warning pictogram	Location
<p>Warning:</p> <ul style="list-style-type: none"> Read the safety rules in the user's manual before using or intervening on the front lifting (Chapter H). Do not use the front lifting when a frontal loader is coupled to the tractor. <p>(Warning symbols according to the tractor's equipment and national regulations enforced)</p>		



-
- | | |
|---|---|
| 6 – Not used. | 30 – Auxiliary hydraulics activation switch. |
| 7 – Linkage position adjustment wheel. | 31 – Auxiliary spool valve control adjustments. |
| 8 – Transmission neutral contactor. | 32 – Front power take-off control. |
| 9 – Engine speed +/- switches. | 33 – Power take-off automation selector. |
| 10 – Engine speed 1,2 memory switch. | 34 – Front axle suspension switch. |
| 11 – Manual accelerator lever. | 35 – Rear power take-off controls. |
| 12 – Hexactiv switch. | 36 – Rear PTO brake switch. |
| 13 – Not used. | 37 – Hand brake lever. |
| 14 – Lifting control contacts. | 38 – Event counter connector. |
| 15 – Rear screen wash/wipe switch. | 39 – 7 pin ISO connector. |
| 16 – Electric rear view mirrors defroster switch. | 40 – Cable routing. |
| 17 – Dipped/full beam selector. | 41 – Linkage control panel. |
| 18 – Automatic A/C control panel. | 42 – Electric cabinet supply socket. |
| 19 – Radio. | 43 – PTO speeds selection levers. |
| 20 – Right-hand loudspeaker. | 44 – Crawler range selection lever. |
| 21 – Electric wing mirror control. | 45 – Automatic pick-up hitch control lever. |
| 22 – Control panel for work lights and rotating beacon. | 46 – Ashtray. |
| 23 – Warning light switch. | |
| 24 – Transport/working mode selector. | |









3 STARTING CONTACT

<p>P</p>	<p>Parking (in the "stop" position, press in the key to turn it to "P")</p>	
	<p>Ignition off/engine stopped</p>	
<p>+</p>	<p>Ignition on (autotest of lights on the console, automatic pre-heating)</p>	
	<p>Start</p>	

Note: In parking position "P" the ignition is off and only the radio, digital clock and cigar lighter remain on.



Primary alarms

<p>STOP WARNING LIGHT (1)</p>		<p>ENGINE COOLANT TEMPERATURE GAUGE (4)</p>	
<p>The "STOP" warning blinks with the indicators (4, 5, 6) or symbols appear on the display (2) with the buzzer indicate a sever fault. You MUST stop IMMEDIATELY when it is safe to do so.</p>		<p>If the engine temperature indicator needle reaches the red zone, the 'stop' light comes on. This indicates overheating:</p> <ul style="list-style-type: none"> - Remove immediately the load applied to the engine. - Let the engine run idle for a few minutes. - Check the following points: <ul style="list-style-type: none"> - Coolant level in the expansion tank: Stop the engine if the level of coolant is too low. - Water pump belt: Check that the belt is not loose or snapped. - Radiator and radiator grilles: Clean if there is any clogging (dust, plant material, etc). - Let the engine cool. <p>To carry out these operations, refer to chapter L.</p> <p>If overheating continues, call your CLAAS workshop.</p>	
<p>ENGINE OIL PRESSURE WARNING LIGHT (2)</p>		<p>BRAKE FLUID LEVEL LOW LIGHT (2) (1)</p>	
<p>If this symbol appears on the display (2) "Stop the engine immediately" and check the oil level. If the level is too low, below the minimum mark, add oil. If the indicator stays on and the oil level is normal, call a CLAAS approved workshop.</p>		<p>When the brake fluid level is too low, the warning light comes on. Stop immediately and call your CLAAS approved workshop.</p>	
<p>(1) Depending on option and model.</p>			
<p>HYDRAULIC CIRCUIT OIL PRESSURE WARNING LAMP (2)</p>		<p>BRAKING SYSTEM PRESSURE WARNING LAMP (2) (1)</p>	
<p>When this symbol is displayed during usage, it means that the rear axle pilot or lubrication pressure is insufficient. Call your CLAAS approved workshop.</p>		<p>The light is on and steady when the operating pressure is incorrect. Stop immediately and call your CLAAS approved workshop.</p> <p>Note: After starting the engine, the indicator may flash for the time required for the accumulator to reach service pressure (Max: 1 min). The indicator may also be used when service pressure becomes too high. In this case, call your CLAAS approved workshop.</p>	
<p>(1) Depending on option and model.</p>			



10 SIGHT

4357

The sight (1) is located at the front of the bonnet. This reference helps the driver to follow a furrow during field work.



760hsn01m



13 CAB SUSPENSION

46

The cab suspension is adjusted as follows⁽¹⁾:

- Position the tractor on flat and level ground.
- Undo screws (1) on both sides by several turns.
- Undo nuts (2) on both sides.
- Move the suspension arms (3) in parallel so that each of its ends line up with holes and slots (4) (5).

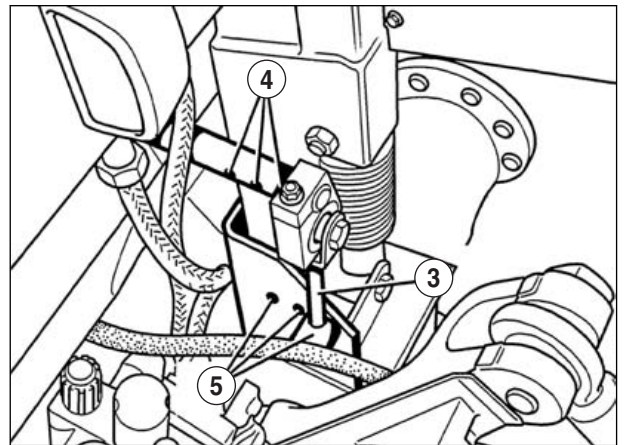

841hsn13

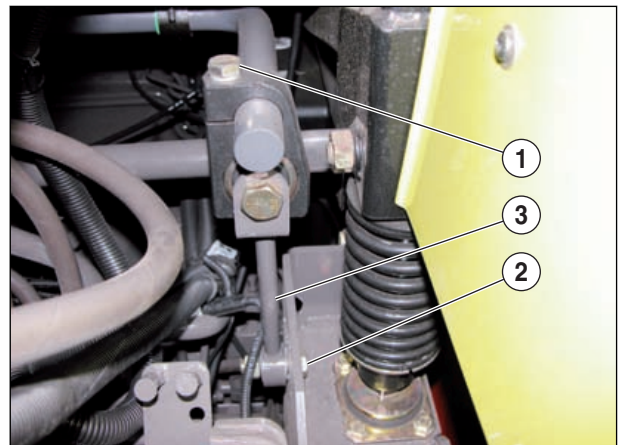

841hsn38

Each position corresponds to a suspension setting:

- Position (A): Soft setting.
- Position (B): Normal setting.
- Position (C): Hard setting.

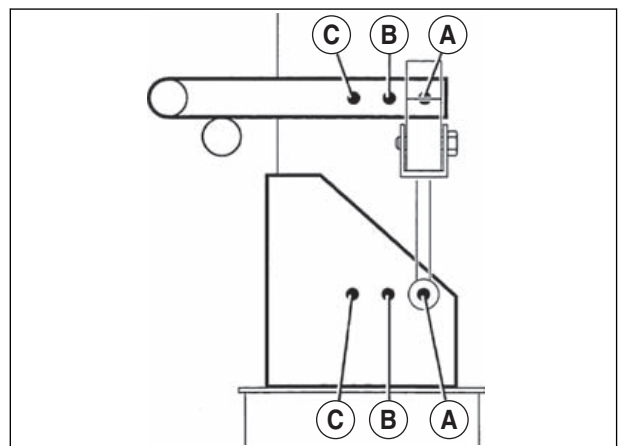

841hsn14

- Tighten the screws (1) and nuts (2):
 - Tightening torque: 150 Nm

(1) Depending on equipment fit.



8 BATTERY

8.1 BATTERY COMPARTMENT

5976



CAUTION

- Avoid generating sparks or open flames next to the battery. Comply with safety instructions when welding (See chapter L).
- Handle the battery with great care because it contains sulphuric acid that must not come into contact with the eyes or skin. Wear gloves and goggles. In case of projection of acid on your skin or in your eyes, thoroughly rinse with water immediately, and call a doctor.

Important: Do not disconnect the battery while the engine is running. The alternator may be damaged.

Important: Before connecting or disconnecting the battery, check the polarity.

Note: Dispose used batteries according to currently enforced regulations.

- 1 – Lock (battery access cover).
- 2 – Lock (fuse box access cover).
- 3 – Battery master switch.

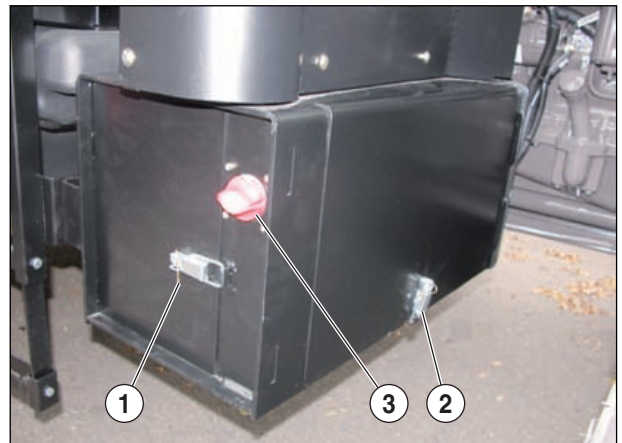

601msn81

- 4 – Fuse box.
- 5 – Battery.

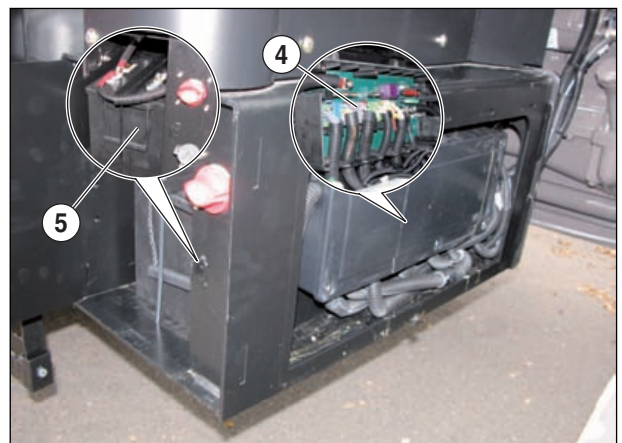

601msn82



Fuses	Designation	Current
F3	Working lights (grill)	10A
F4	Front electrics unit supply socket	25A
F5	Rear electrics unit supply socket	25A
F6	ISOBUS	30A
F7	Pre-heating	50A
F8	Engine computer	10A
F9	Front electrics unit supply socket	5A
F10	Rear electrics unit supply socket	5A
F11	Main and dipped headlights	15A
F12	Main beam lights	10A
F13	Dipped headlights	10A
F14	Working lights (foot plate)	10A
F15	Lighting socket trailer/front implement	10A
F16	Lighting socket trailer/rear implement	10A
F17	Not in use	25A

Note: Allocations per tractor part.

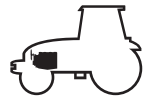

3 SAFETY

3.1 OPERATION

6437

When working, the computers monitor engine operation continuously.

According to the anomaly, the calculators apply the best protection strategy for the engine, by limiting its power.

Check that it is not a temporary fault by switching off, waiting at least 20 seconds and restarting the engine. If the fault persists, call your CLAAS approved workshop.

3.2 INSTRUMENT PANEL

224

Instrument panel warning lights indicate failures associated with oil pressure and coolant temperature. See chapter B.

3.3 RECOMMENDATIONS

5824

General

Choose a gear which avoids exceeding maximum speed authorized on the road in the destination country.

The engine of your tractor has been specifically designed for agricultural use. The engine complies with the TIER III emission level. Follow a few simple rules and you will get optimum performance from your engine.

Running in

The first 100 hours of operation are important since, to a large extent, they determine the future life of the engine.

- Avoid working at light loadings or for long periods at idling speed during the first 100 hours.
- Avoid overload operations by using a very high gear ratio.
- Take particular care with fluid levels (oil and coolant) and always monitor engine temperature.

Operating temperature

The engine is designed to run at maximum torque. However, do not solicit maximum load from the engine as long as it has not reached its operating temperature. To do this, always allow it to warm up by operating at half-speed for 10 minutes.

If during operation the indicated temperature enters the red zone, stop working. Carry out the checks indicated in chapter L.

Revolution speeds

Idle rpm is not an ideal speed for engine operation. You should therefore stop the engine when the tractor is not being used.

The maximum no-load engine speed is reached when the accelerator lever is pushed at maximum and transmission set to neutral. Running the engine at this speed when the tractor is stationary is not recommended, especially when the engine is cold.

Operating at intermediate power

When working with the accelerator pushed at maximum, if engine speed is constantly above maximum power load and does not vary much, the tractor is running in underload.

If you are working with the power take-off, it is also possible, in a part load condition, to use the PTO in the economy mode: in this case match engine speed to the standard PTO economy speed.

Full power operation

Once the gear chosen properly (according to the tool and work to be performed), push the accelerator lever to maximum. In these conditions, engine speed must be close to maximum power speed.

If the resistant strength drops punctually, the engine speed rises in a range between maximum power speed and maximum no-load speed.

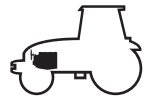

6 CLAAS POWER MANAGEMENT

2685

Any modification of the electronic calculator to improve engine power is strictly forbidden.

This can cause:

- Excess fuel consumption.
- Non compliance with antipollution standards.
- Loss of manufacturer guarantee.

All parameters are frozen in the engine calculator. CLAAS waives any liability in case of modification on the electronic calculators of CLAAS tractors.

This function is only available on the ARION 540-640.

"CLAAS Power Management", also called "Boost", boosts engine power according to the tractor's use (hydraulic, power take-off, gearbox...), in order to have maximum power available at all times.

Note: Additional power is only available in forward gear.

Transport

Additional power is 100 % available when ratios C or D are engaged.

Work

Additional power is available between 0 and 100 % depending on:

- The power consumed by the PTO.
- The power consumed by the hydraulic systems.
- The power consumed by the gearbox.

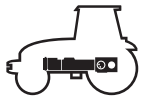

Range		Ratio	Tractor forward speeds at an engine speed of 2 200 1/min with the following rear tyres:					
			20.8R38 520/85 R 38 580/70 R 38 650/65 R 38		18.4R38 460/85 R 38 600/65 R 38 520/70 R 38		16.9R38 420/85 R 38 480/70 R 38 540/65 R 38	
			km/h	mi/h	km/h	mi/h	km/h	mi/h
Crawler (400 m/h)	A	1	0,44	0.28	0,42	0.26	0,41	0.25
		2	0,53	0.33	0,50	0.31	0,49	0.30
		3	0,63	0.39	0,59	0.37	0,57	0.36
		4	0,75	0.47	0,71	0.44	0,69	0.43
		5	0,89	0.55	0,84	0.52	0,81	0.50
		6	1,10	0.66	1,00	0.63	0,98	0.61
	B	1	1,20	0.75	1,10	0.70	1,10	0.68
		2	1,40	0.90	1,40	0.85	1,30	0.82
		3	1,70	1.05	1,60	0.99	1,60	0.96
		4	2,00	1.27	1,90	1.20	1,90	1.16
		5	2,40	1.49	2,30	1.41	2,20	1.36
		6	2,90	1.79	2,70	1.69	2,60	1.64

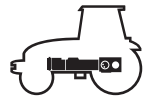

Range		Ratio	Tractor forward speeds at an engine speed of 2 200 1/min with the following rear tyres:			
			20,8R38 520/85 R 38 580/70 R 38 650/65 R 38		18.4R38 460/85 R 38 600/65 R 38 520/70 R 38	
			km/h	mi/h	km/h	mi/h
Normal	A	2	1,9	1.2	1,8	1.1
		3	2,3	1.4	2,2	1.3
		4	2,8	1.7	2,6	1.6
		5	3,2	2.0	3,1	1.9
		6	3,9	2.4	3,7	2.3
	B	1	4,4	2.7	4,1	2.6
		2	5,3	3.3	5,0	3.1
		3	6,2	3.8	5,8	3.6
		4	7,4	4.6	7,0	4.4
		5	8,8	5.4	8,3	5.1
		6	10,5	6.5	9,99	6.2
	C	1	8,9	5.5	8,4	5.2
		2	10,7	6.7	10,1	6.3
		3	12,6	7.8	11,9	7.4
		4	15,1	9.4	14,3	8.9
		5	17,8	11.0	16,8	10.4
		6	21,4	13.3	20,2	12.5
	D	1	23,6	14.7	22,3	13.8
		2	28,4	17.6	26,8	16.6
		3	33,3	20.7	31,4	19.5
		4	40,1	24.9	37,8	23.5
		5	47,1	29.3	44,4	27.6
		6	50,8	31.5	50,8	31.5
		"Overdrive" 1/min	1 970		2 090	

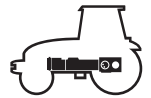

Note: The small "N" (B) indicates that the reverser clutches are in neutral.

To shift from forward to reverse, move lever (1) directly from position (A) to position (C).

To shift from reverse to forward, do the opposite: move lever (1) directly from position (C) to position (A).

When in positions (A) or (C), if the reverser lever is pulled towards the steering wheel (position (D)), the tractor drive is declutched.

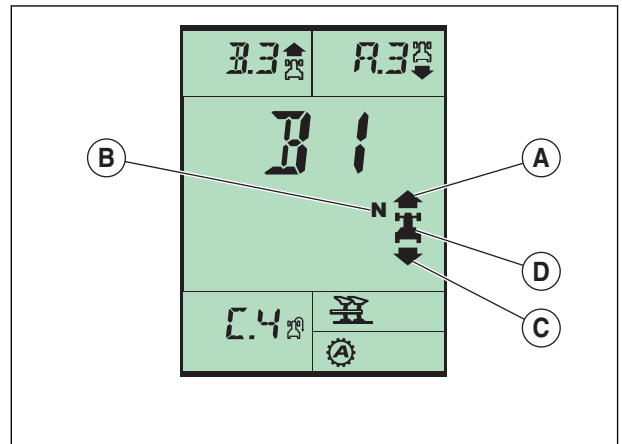

326msn44

The direction of travel is also indicated on the instrument panel:

A- Forward.

B- Reverser neutral.

C- Reverse.

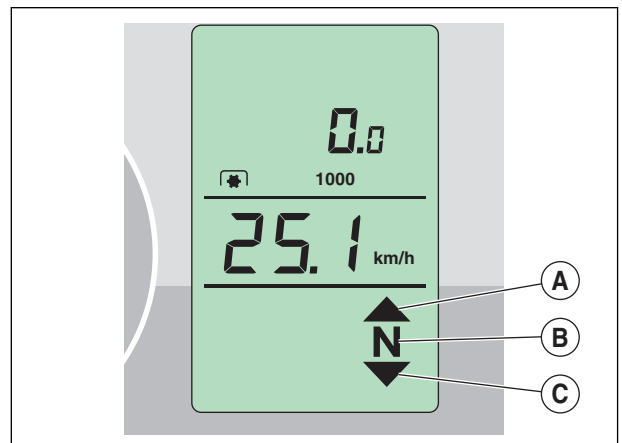

601hsn0h

5.4 REVERSER PROGRESSIVITY ADJUSTMENT

5.4.1 Operation

943

Adjustment of the progressivity of the reversal operation enables independent settings of the aggressiveness of the forward and reverse drive clutches.

5.4.2 Adjustment

2632



CAUTION

Before driving on the road, adjust reverser progressiveness to ensure the clutch is as responsive as possible.

Note: For work likely to damage the superficial soil layer, adjust reverser progressiveness as to ensure the clutch is as smooth as possible.

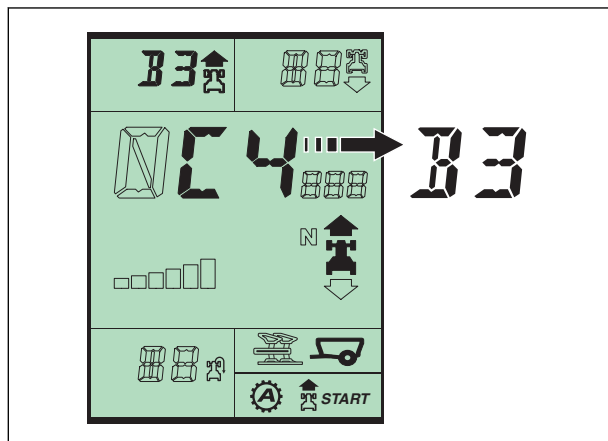
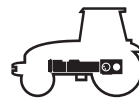

326msn43

7.3.2 Adjustment

3230

The manoeuvre gear can be changed as follows:

- Press button (1).
- Change the manoeuvre gear using the Drivestick.
- Press button (1) again to quit the manoeuvre gear function and record the new setting.

Note: Programming can be carried out with the tractor moving or stationary with the reverser in neutral or the clutch pedal pressed.

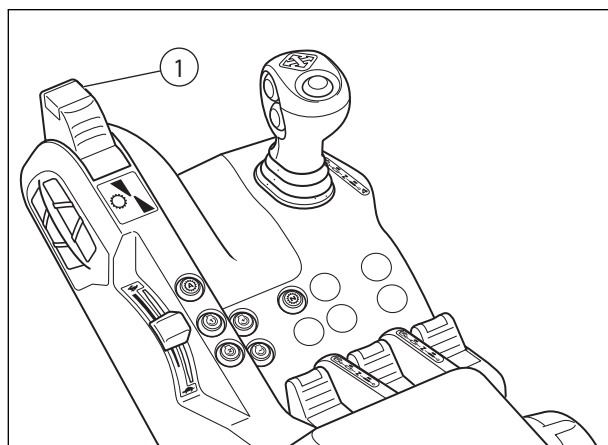

326msn54

7.3.3 Operation

713

The transmission computer makes sequenced gear changes (every 0,5 seconds) until the manoeuvre gear is reached when changing down and every 1,4 seconds when changing up.

The manoeuvre gear mode is cancelled when the engine is stopped.

The manoeuvre gear is recorded before the engine is stopped.

Engagement of the manoeuvre ratio disengages Hexactiv programming. Cancelling the manoeuvre ratio function will reengage Hexactiv programming.

In the working mode, the manoeuvre gear operates only in the currently selected range. Selecting Range + or Range - causes the immediate cancellation of the manoeuvre gear mode.

In the road mode, it can operate in the current range or in another range.

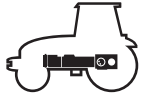

REAR AXLE

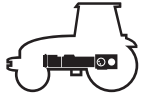

If the error code and/or alarm indicator have not disappeared, repeat the previous operations.

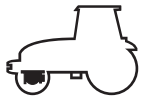

3.2.2 Operation

860

The front axle is engaged automatically when speed drops below 14 km/h.
The front axle is disengaged automatically when speed increases above 14 km/h.

3.3 PERMANENT MODE

3.3.1 Operation

3187

This is obtained by:

- Press the switch (1) when speed exceeds 14 km/h.
- Pressing the switch (1) for more than 2 seconds when speed drops below 14 km/h.

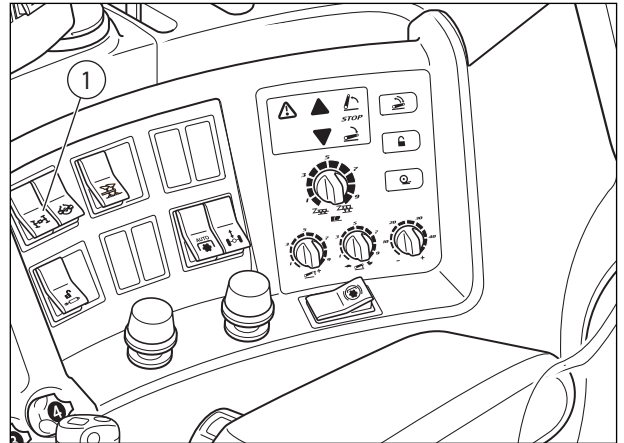

601hsn1e

The front axle engagement indicator (1) turns on in the instrument panel.

To disengage the front axle, press the switch.

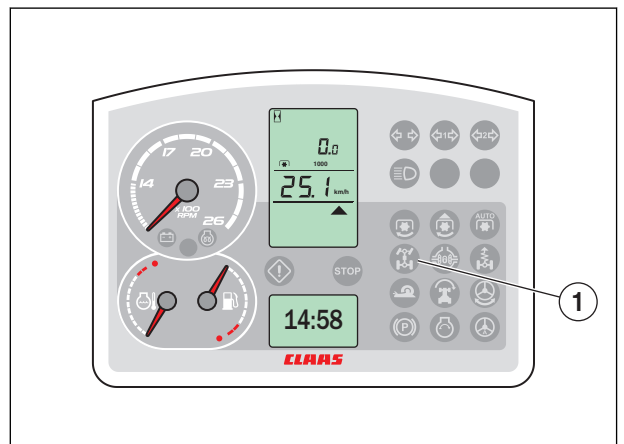

453msn00

3.3.2 Operation

862

The front axle is permanently engaged.

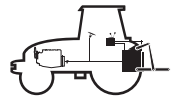

Valve plant composed of 2 valves

Valve plant composed of 2 valves controlled by 2 levers.

Control	Pressure connector	Colour code
1	1	Blue
2	2	Brown

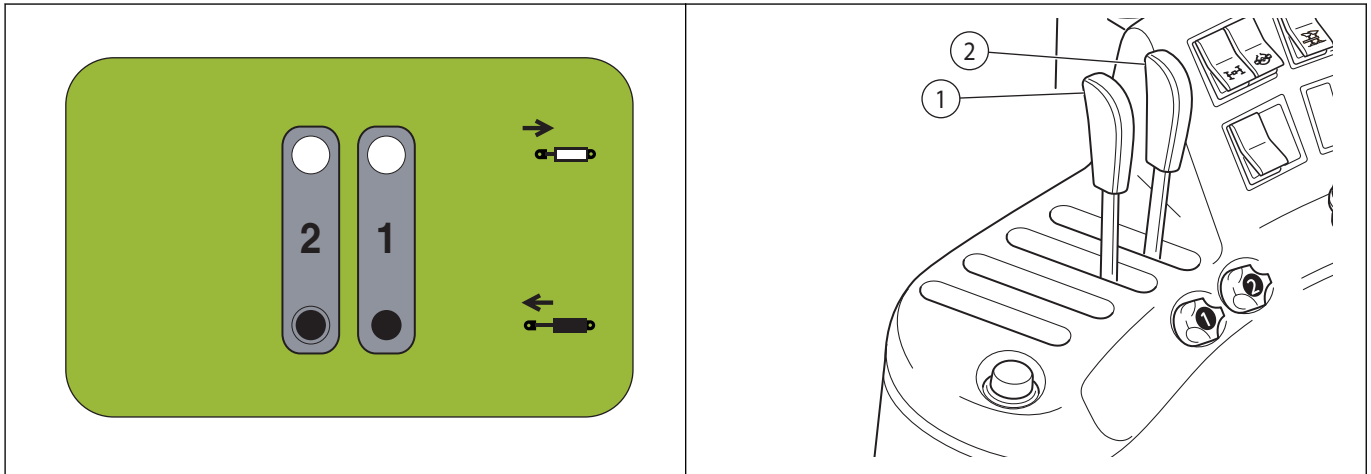

Valve plant composed of 3 valves

Valve plant composed of 3 valves controlled by 3 levers.

Control	Pressure connector	Colour code
1	1	Blue
2	2	Brown
3	3	Green

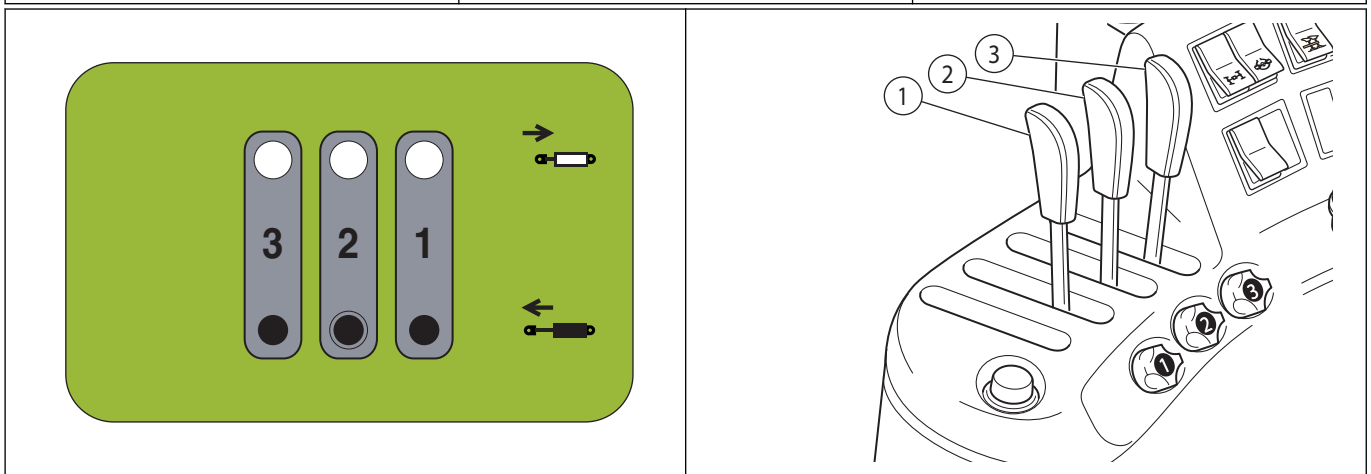

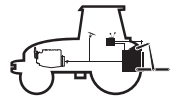

3.3 CONTROLS

4157

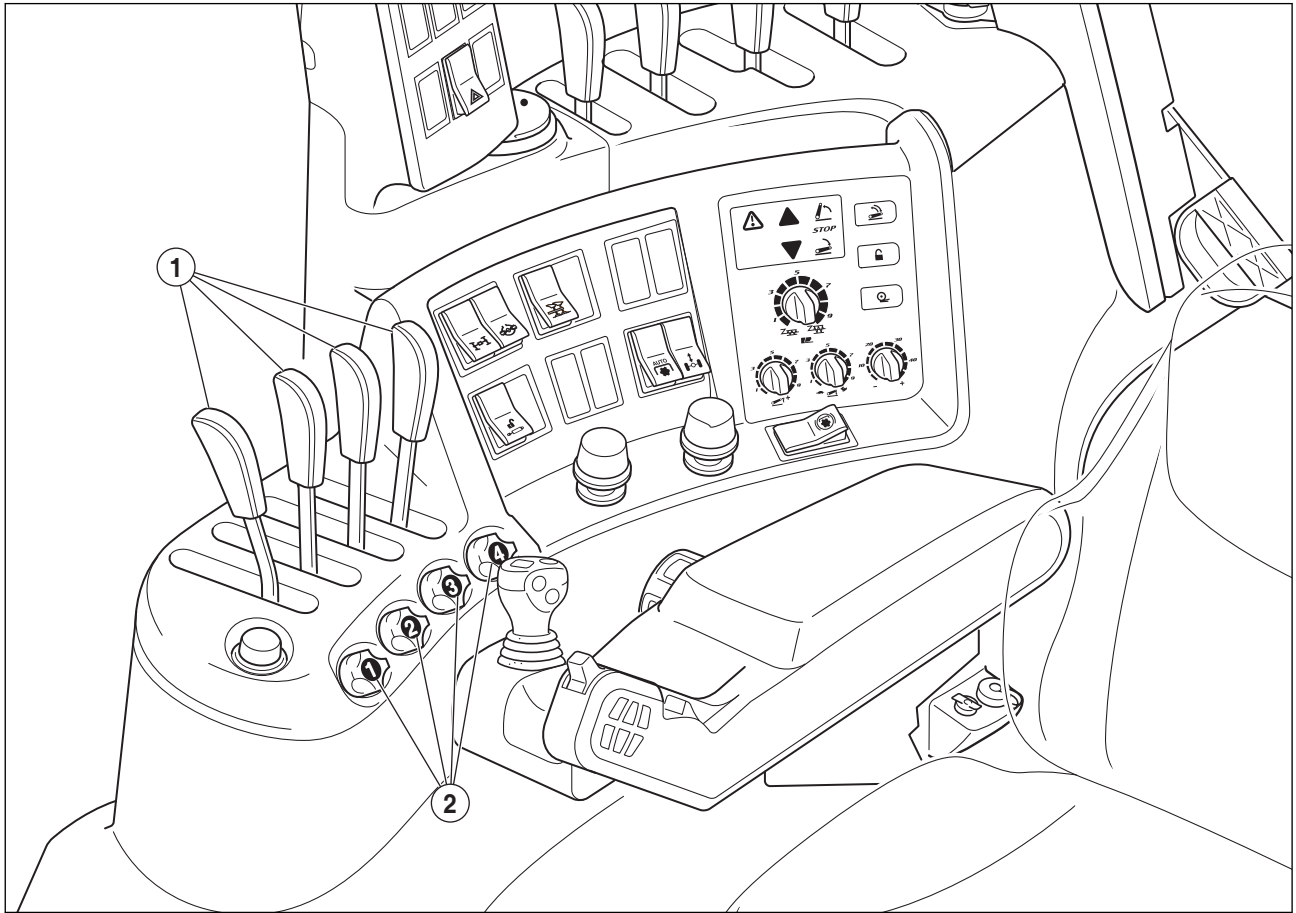

391hsn0jm

- 1 – Auxiliary spool valve control levers.
- 2 – Auxiliary spool valves adjustment rotary knobs.

3.4 CONTROL LEVERS

6448



CAUTION

Always check that nobody is inside the tool deployment zone.

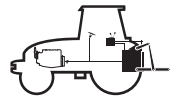

4 USING THE LINKAGE

821

If the warning light (1) illuminates, take the following action:

- Press the DOWN button (3).
- Find the real position of the arms using the setting knob (2), until the warning light (1) switches off.

The linkage is now operational.

Note: *When the setting knob reaches the real position of the lifting arms, the lifting responds to the setting.*

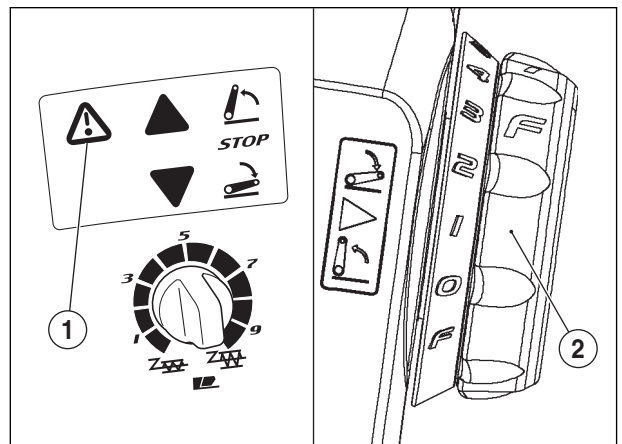

382htn10

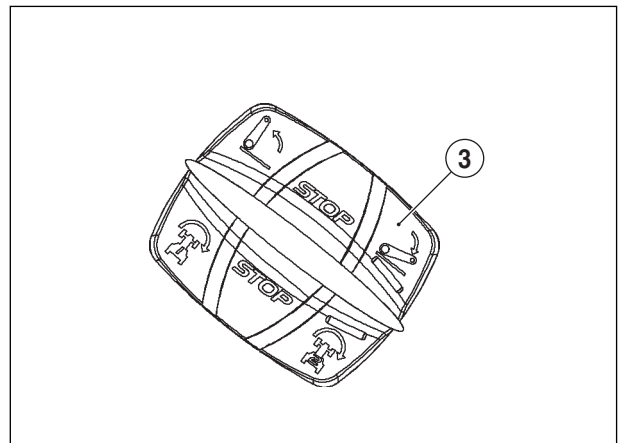

382htsn40

CLICK HERE TO **DOWNLOAD** THE COMPLETE MANUAL

- Thank you very much for reading the preview of the manual.
- You can download the complete manual from: www.heydownloads.com by clicking the link below



- Please note: If there is no response to CLICKING the link, please download this PDF first and then click on it.

CLICK HERE TO **DOWNLOAD** THE COMPLETE MANUAL

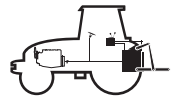

12 EXTERNAL CONTROLS

12.1 OPERATION

3199



CAUTION

- Apply the handbrake when leaving the tractor.
- Do not stand in the risk area located between the tool and the tractor.
- Stand next to the tractor.
- Stay at a distance from the linkage area.
- External controls override the internal controls. The external controls on the left wing override the controls on the right wing.

These two push buttons on each rear wing enable the arms to be raised (1) or lowered (2) when attaching or adjusting implements.

- Immobilise the tractor.
- When pressing a button, we obtain a displacement of about 10 cm in the direction requested.
- To obtain a greater movement, the control has to be released and pressed again.

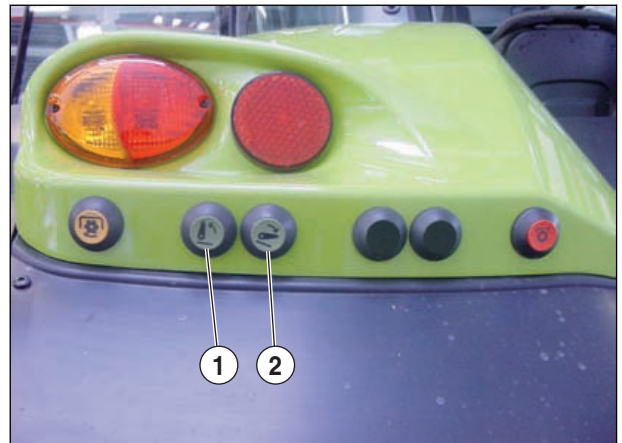

391hsn96

12.2 OPERATION

835



CAUTION

During hitching operations or when using the external linkage control, the operator must remain outside the hitch frame.

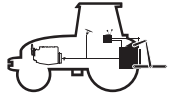

8 OPERATION

740

Important: Before operating the PTO rpm selector lever, the rear PTO must be disengaged.

Note: To protect the tool in economic speed, the transmission calculator disengages the power take off if engine speed exceeds 1 900 1/min.

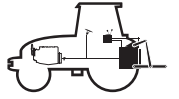

For information, if the load to lift is light, the hitch configuration corresponding to the minimum mechanical benefit is (B):

- Upper linkage in the lower hole.
- Jacks fixed to the farthest hole from the towing hooks.
- Jacks shortened to minimum.

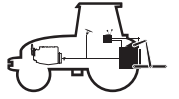

9 TOW HOOK

850

Withdraw pin (1) to release the latch (2).

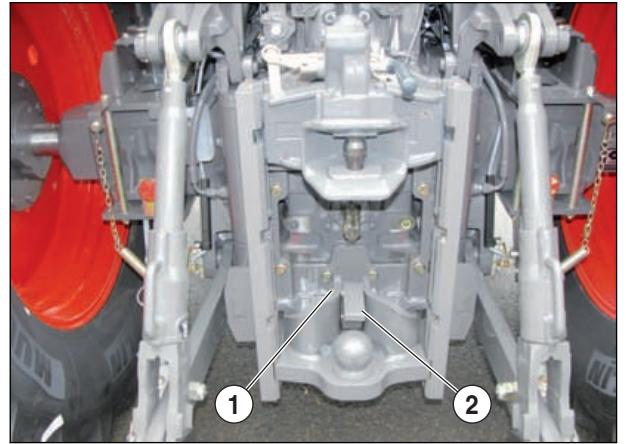

544msn21



2.2.4 Oil collection can

4562

Oil leaks from hydraulic couplers are collected in the can (1). If required, empty the can (1):

- Disconnect the hose (3).
- Pull the can (1) from the holder (2).
- Unscrew the plug (4).
- Collect used oil in a specific container.
- Refit the can (1).

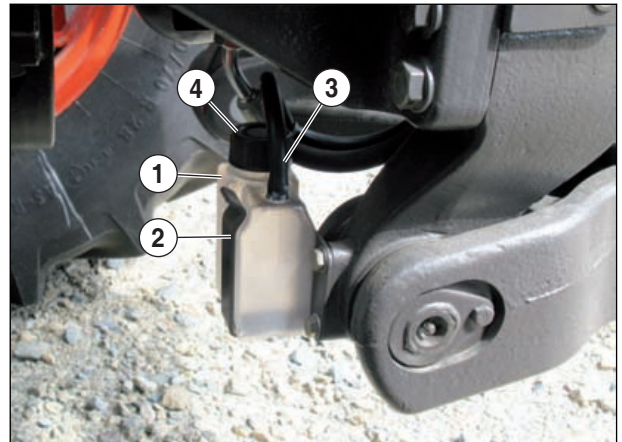

395msn01m

Note: Dispose oil collected according to currently enforced regulations.

2.3 OPERATION

4163



CAUTION

- Always check that nobody is inside the tool deployment zone.
 - No tool must be connected to the rear pressure connectors of spool valve 3.
- Pressure outlets located at the tractor front are controlled by control (3).

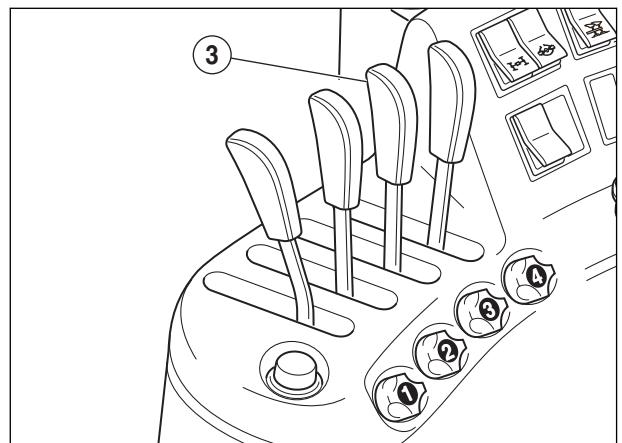

391hsn09m



FRONT LINKAGE



Label (1), reminding the operation laws of front lifting, is affixed next to the front lifting isolation valve (According to tractor equipment):

- A – Front lifting locking.
- B – Front linkage in single-acting operation.
- C – Front linkage in double-acting operation.

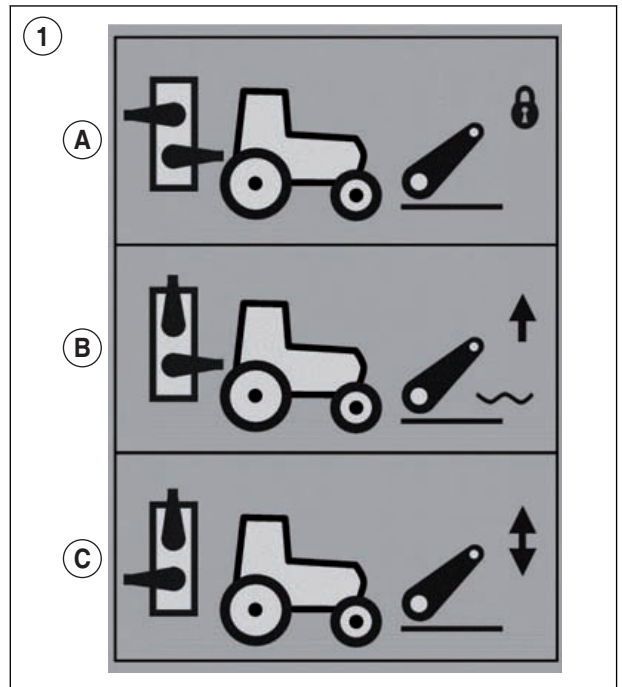

394msn17m

- Press button (1).
- Warning light (1) comes on.



391msn30

To activate the "Electropilot" joystick:

- Press button (1).
- Warning light (1) comes on.

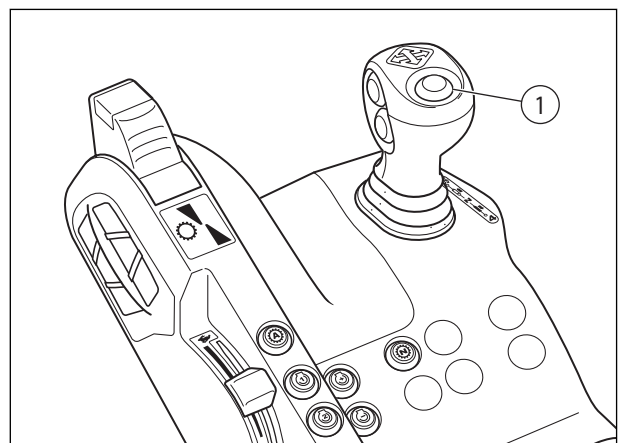

391msn07



2 DISPLAY

4227

Engagement of the front power take-off is indicated by light (1) located in the control panel.

The rotation speed of the front power take-off (2) is displayed in the control panel.

For more information, refer to the dashboard description, in chapter B.

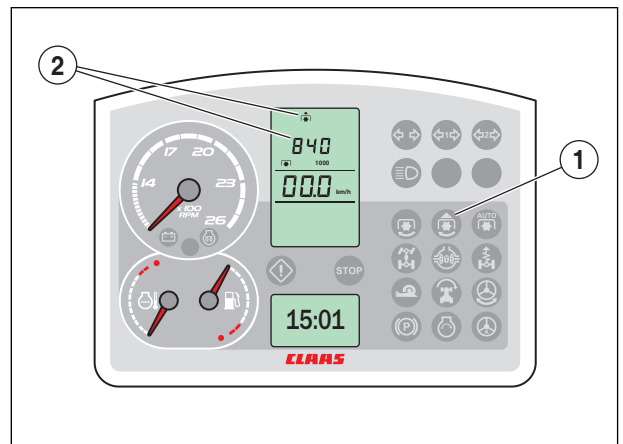

601msn73m



Fig. (B) - ARION 600.

- 1 – 4 H M18-80, P2.5, 10.9, ZBJ screws
 - Tightening torque 340 Nm
- 2 – 8 H M18-60, P2.5, 10.9, ZBJ screws
 - Tightening torque 340 Nm
- 3 – 6 H M18-55, P2.5, 10.9, ZBJ screws
 - Tightening torque 340 Nm
- 4 – 4 H M20-65, P2.5, 10.9, ZBJ screws
 - Tightening torque 450 Nm
- 5 – 4 H M14-70, P2, 10.9, ZBJ screws
 - Tightening torque 220 Nm
- 6 – 4 H M16-40, P2, 10.9, ZBJ screws
 - Tightening torque 350 Nm



CAUTION

To use a front loader, the tractor must be fitted with a rear stiffener.

For safety purposes, after fitting a front loader adaptation frame, the hydraulic timer (timeout function) for the electrohydraulic valves must be deactivated permanently by the CLAAS approved workshop having performed the assembly (see chapter G). The hydraulic timers must remain deactivated as long as the frontal loader adaptation frame is fitted. Non-compliance with these instructions may cause severe accidents.

Tractors to be used in the European Community must, if using a front loader, be equipped with a protective structure (FOPS - Falling Object Protective Structure) which protects the driver from falling objects.

Any CLAAS tractors ordered from the plant with a frontal loader are already fitted with a FOPS roof. For safety purposes, the CLAAS tractors ordered in series without frontal loader nor FOPS roof or only with an anti-flipping bar (safety bar), must in no event be fitted with a frontal loader nor used with a frontal loader.

In countries outside the European Union, apply the appropriate national provisions.

Using the frontal loader to transport goods in public areas is forbidden. Using the frontal loader to transport goods in non public areas is possible only in a restricted manner. In this case, the instructions in the user manual of the frontal loader manufacturer must be applied.

Always comply with national regulations enforced.

For more information, refer to your CLAAS approved workshop.

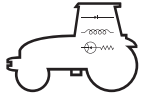

-
- | | |
|---|--|
| 4 – Area worked. | B – The procedure allowing the total and partial counter resetting is the same for all counters. |
| 5 – Time worked. | P – Partial counter. |
| 6 – Area worked per hour. | T – Total counter. |
| 7 – Tool width adjustment. | |
| 8 – Partial travelled distance. | |
| 9 – Partial travelled distance counter resetting. | |

Note: *The surface area can only be counted when the rear linkage is in the working position.*

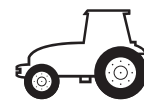

J - WHEELS AND TYRES



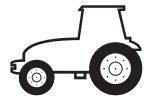

2.2.2 Tables of front tracks

6645

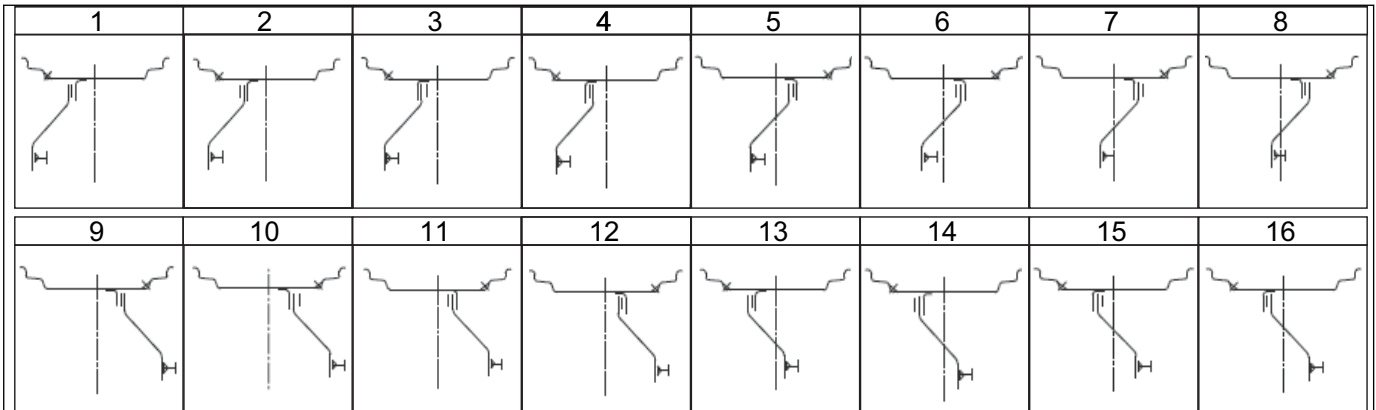

511hsn09m

Type of front axle 20.19-9 / 20.22-7																	
Rigid Front Axle (ARION 510-520-530-540-610)																	
Rims with connector bars or welded circle																	
Front tracks (mm)																	
Tyres	Type	1	2	3	4	5	6	7	8	9	10	11	12	13	14	15	16
13.6R28	W 12	1 529	1 560	1 591	1 622	1 825 (1)	1 794	1 763	1 732	2 225	2 194	2 163	2 132	1 929	1 960	1 991	2 022
340/85R28	W 12	1 529	1 560	1 591	1 622	1 825 (1)	1 794	1 763	1 732	2 225	2 194	2 163	2 132	1 929	1 960	1 991	2 022
380/70R28	W 12	1 528	1 559	1 590	1 621	1 824 (1)	1 793	1 762	1 731	2 225	2 194	2 163	2 132	1 929	1 959	1 990	2 021
440/65R28	W 14 L	1 529	1 560	1 591	1 622	1 825 (1)	1 794	1 763	1 732	2 225	2 194	2 163	2 132	1 929	1 960	1 991	2 022
14.9R28	W 12	1 528	1 559	1 590	1 621	1 824 (1)	1 793	1 762	1 731	2 224	2 193	2 162	2 131	1 928	1 959	1 990	2 021
380/85R28	W 12	1 528	1 559	1 590	1 621	1 824 (1)	1 793	1 762	1 731	2 224	2 193	2 162	2 131	1 928	1 959	1 990	2 021
420/70R28	W 14 L	1 526	1 557	1 588	1 619	1 823 (1)	1 792	1 761	1 730	2 223	2 192	2 161	2 130	1 926	1 957	1 988	2 019
480/65R28	W 15 L	1 527	1 558	1 589	1 620	1 823 (1)	1 792	1 761	1 730	2 223	2 192	2 161	2 130	1 927	1 958	1 989	2 020
400/80R28	W 12	1 527	1 558	1 589	1 620	1 824 (1)	1 793	1 762	1 731	2 224	2 193	2 162	2 131	1 927	1 958	1 989	2 020

(1) Track on delivery.

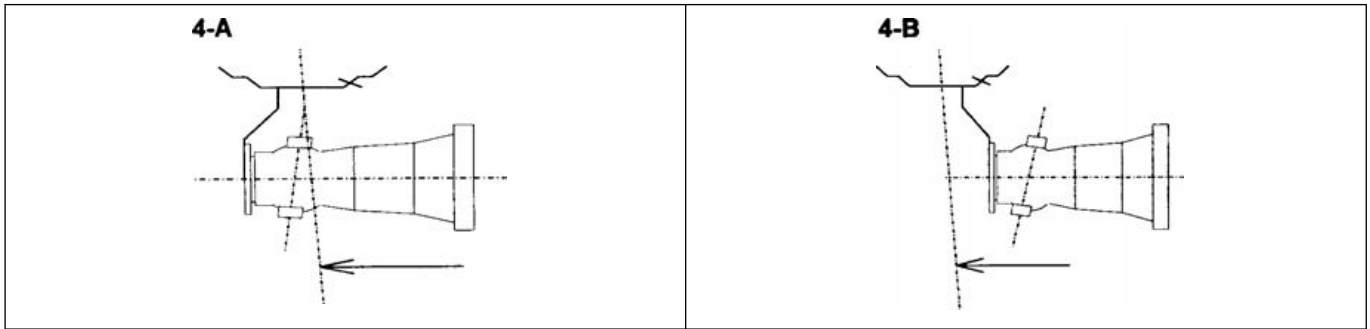
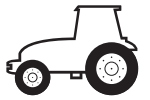

Type of front axle 20.29-13

Rigid Front Axle (ARION 630)

Rims with fixed wheel disc		Minimum track width (mm)		Maximum track width (mm)	
Tyres	Type	4-A		4-B	
14.9R28	W 12	1 778 ⁽¹⁾		1 878	
380/85R28	W 12	1 778 ⁽¹⁾		1 878	
420/70R28	W 14 L	1 777 ⁽¹⁾		1 877	
480/65R28	W 15 L	1 777 ⁽¹⁾		1 877	
520/60R28	TW 18 L	1 780 ⁽¹⁾		1 866	
400/80R28	W 12	1 778 ⁽¹⁾		1 878	
16.9R28	W 15 L	1 776 ⁽¹⁾		1 876	
420/85R28	W 15 L	1 776 ⁽¹⁾		1 876	
480/70R28	W 15 L	1 776 ⁽¹⁾		1 876	
540/65R28	W 18 L	1 776 ⁽¹⁾		1 876	
440/80R28	W 15 L	1 775 ⁽¹⁾		1 875	

⁽¹⁾ Track on delivery.

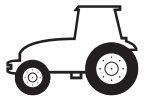

420/85R38	DWW 15 L					1 739	1 708	1 669	1 638	2 139	2 108	2 069	2 038	1 835 (1)	1 866	1 905	1 935
480/70R38	DWW 15 L					1 739	1 708	1 669	1 638	2 139	2 108	2 069	2 038	1 835 (1)	1 866	1 905	1 935
540/65R38	DWW 18 L					1 739	1 708			2 139	2 108	2 069	2 038	1 835 (1)	1 866	1 905	1 935
18.4R38	DWW 15 L					1 739	1 708	1 669	1 638	2 139	2 108	2 069	2 038	1 835 (1)	1 866	1 905	1 935
460/85R38	DWW 15 L					1 739	1 708	1 669	1 638	2 139	2 108	2 069	2 038	1 835 (1)	1 866	1 905	1 935
520/70R38	DWW 18 L					1 739				2 139	2 108	2 069	2 038	1 835 (1)	1 866	1 905	1 935
600/65R38	DWW 18 L					1 739				2 139	2 108	2 069	2 038	1 835 (1)	1 866	1 905	1 935
480/80R38	DWW 18 L					1 739	1 708	1 669	1 638	2 139	2 108	2 069	2 038	1 835 (1)	1 866	1 905	1 935

(1) Track on delivery.

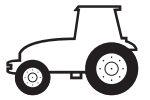

3 WHEELS

6516

Important: Wheel twinning must be used only to reduce soil compaction.

For severe applications:

- Use of combined tools.
- Transport with a public works dipper.
- Twinning.
 - The width of the outer tyre must be equal to or less than that of the inner tyre.
 - Inner and outer tyres must be inflated to the same pressure (in accordance with manufacturer's recommendations).
 - Tractor ballasting must not exceed the values shown in chapter K.
 - Tyre pressures must equal the minimum recommended by the manufacturer.
 - In general, the working speed of a twin-wheeled tractor must be lower than 10 km/h.

Use reinforced wheels. If you do not own such equipment, call your CLAAS approved dealer.

Important: Use reinforcement washers to omit using reinforced wheels. If you do not own such equipment, call your CLAAS approved dealer.

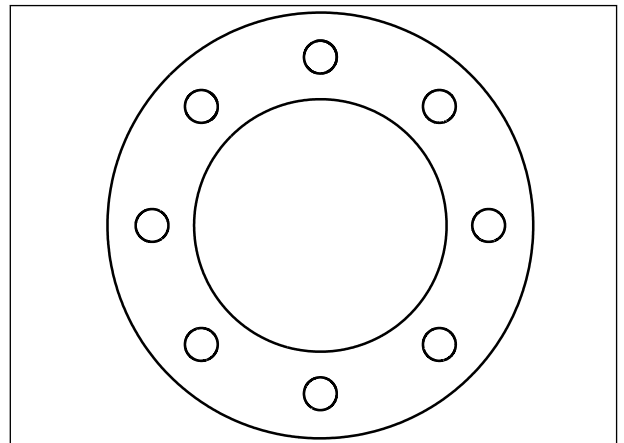

511msn011



5 CAPACITIES

5302

The table below indicates the quantities of lubricant and fluid to be used in each component.

Only use recommended lubricants and fluids.

When topping up, the oil or fluid category must not be changed.

Regular oil changes are essential.

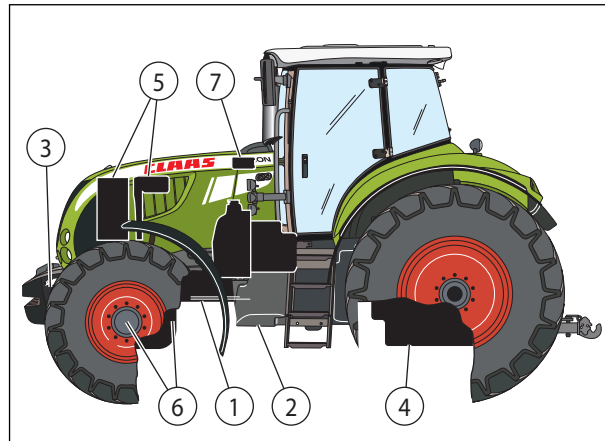

001msn07r

	<i>Tractor components</i>	<i>Capacities</i>		<i>Recommended lubricants/fluids</i>
		<i>Minimum</i>	<i>Maximum</i>	
1	ENGINE			- CLAAS AGRIMOT SDX 15W40 - CLAAS AGRIMOT SDX FE 15W30
	Engine sump 4 cylinders	11,5 l	14 l	
	Engine sump 6 cylinders	15,5 l	18,5 l	
2	FUEL TANK			Diesel quality (see chapter D)
	ARION 500			
	Principal	210 l		
	Additional	50 l		
	ARION 600			
	Principal	280 l		
	Additional	50 l		
3	FRONT POWER TAKE-OFF BOX	2,2 l (with cooler)		CLAAS AGRISHIFT GA12 (API GL4 - GIMA M 1145 - ISO HV 68)
4	TRANSMISSION - LIFT	63 l (min)		- CLAAS AGRISHIFT GA12 - CLAAS AGRISHIFT BIO 45
5	COOLING SYSTEM			Coolant: CLAAS AGRI-COOL
	ARION 500	17,5 l		
	ARION 600	21,5 l		



L - MAINTENANCE





5 REPLACING A WHEEL

6683



CAUTION

- Position the tractor on flat, horizontal and stable ground.
- Use one or more axle stands rather than a jack to maintain the tractor in position.
- Use a device suitable for manipulating the wheels.

Important: It is vital to respect the storage conditions for the wheels and tyres set out below.

- Position the tractor on flat, horizontal and stable ground.
- Lift the tractor using a jack.
- Position axle stands appropriate for the load under the tractor:
 - Under one or more rear axle tubes.
 - Under the front axle to the left and/or right of the differential housing.
- Undo and remove the wheel nuts (1).
- Remove the wheel using suitable lifting equipment.
- Have the tyre and/or the wheel rim repaired if necessary.



511msn00m

- Store the wheel:
 - Away from dust and dirt.
 - Away from sunlight.
 - Away from any source of heat.
 - In a well-ventilated place.
 - Away from any ozone sources (large electrical installations, welding equipment stations etc.).
 - Away from petroleum-based products.
 - Away from chemical substances or solvents.
 - Away from objects that could penetrate the rubber.
 - Inflate the tyre to a pressure greater than that for normal use by 5×10^4 Pa (0,5 bar).
- Replace the wheel using a suitable lifting device.
- Tighten the bolts and nuts (refer to chapter L for the tightening torque):
 - Securing the wheel disc on the hub (1).
 - Securing the wheel disc on the rim (2).
- Respect the inspection frequency for checking the tightness of the wheel disc on the hub within the first 10 hours after the wheel has been tightened.
- Respect the inspection frequency for checking the tightness of the wheel disc on the rim within the first 10 and 40 hours after the wheel has been tightened.



- Remove wing nuts (1).
- Remove air collector (2).

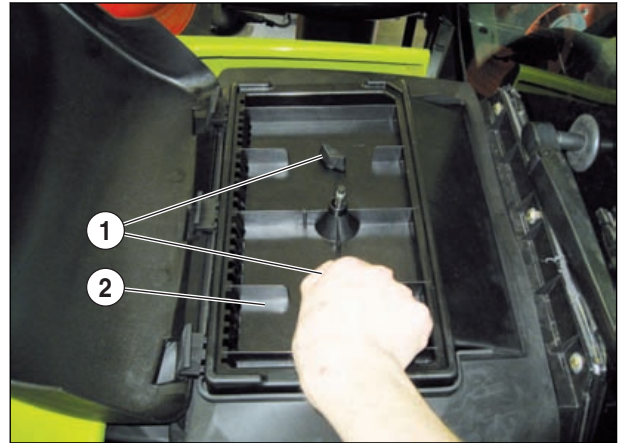

621hsn05

- Remove the main filter (1).
- If necessary, clean with compressed air, by turning the jet from the clean side to the clogged side of the filter. Compressed air pressure must be below 5×10^5 Pa (5 bar).
- Refit the assembly in reverse order to removal, making sure that the parts are the right way round.

Important: Refit the air filter (1) respecting the orientation of the arrows (towards the cab).

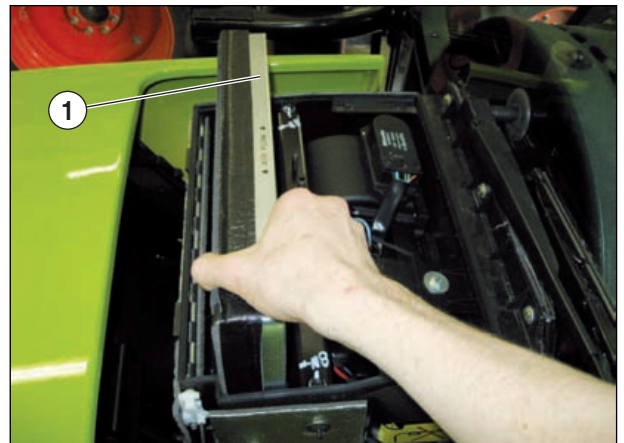

621hsn06

9.2.2 Operation n° 2

908

Cleaning: Cab "recycled" air filter

- Remove the left cover of the control panel.
- Remove and replace the element (1).

Important: The arrows printed on the filter show the air flow direction. They must point to the front of the tractor.

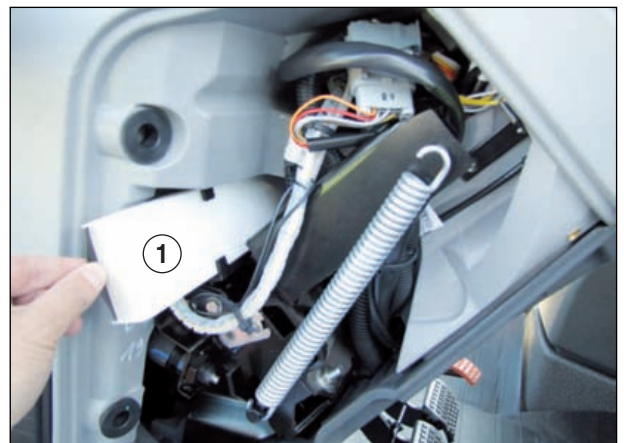

621msn07



- Undo nut (1).
- Remove the prefilter strap (2).

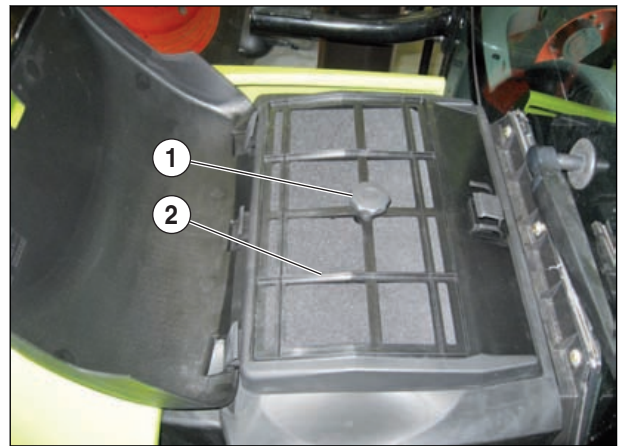

621hsn03

- Remove the prefilter (1).
- If necessary, clean with compressed air, by turning the jet from the clean side to the clogged side of the filter. Compressed air pressure must be below 5×10^5 Pa (5 bar).



621hsn04

- Remove wing nuts (1).
- Remove air collector (2).

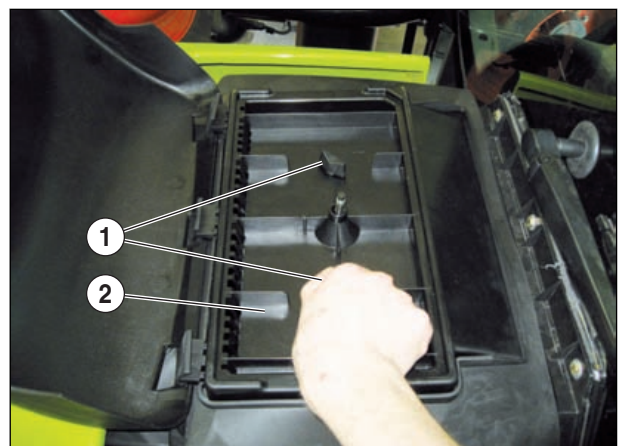

621hsn05

- Remove the main filter (1).
- If necessary, clean with compressed air, by turning the jet from the clean side to the clogged side of the filter. Compressed air pressure must be below 5×10^5 Pa (5 bar).
- Refit the assembly in reverse order to removal, making sure that the parts are the right way round.

Important: Refit the air filter (1) respecting the orientation of the arrows (towards the cab).

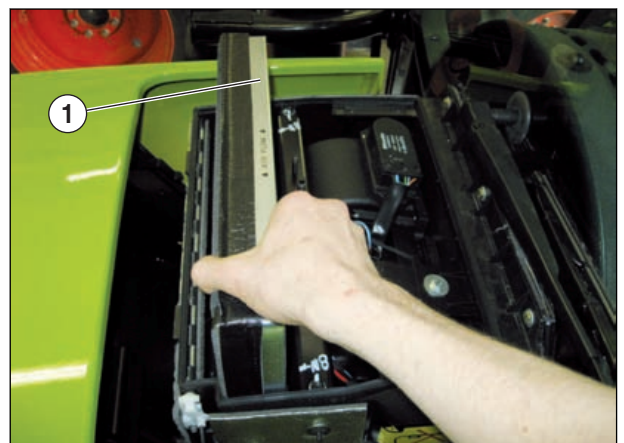

621hsn06



Suspended front axle 2029SI.

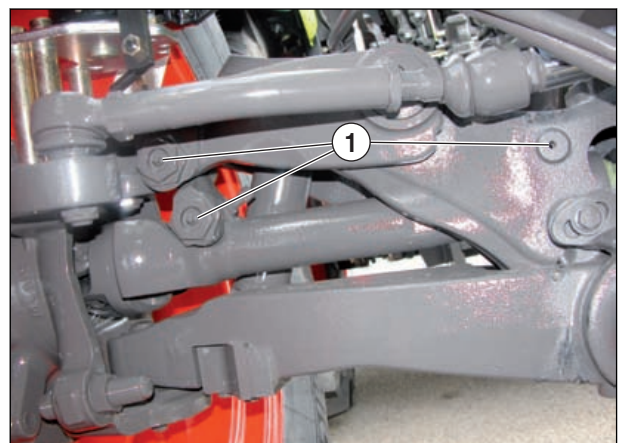
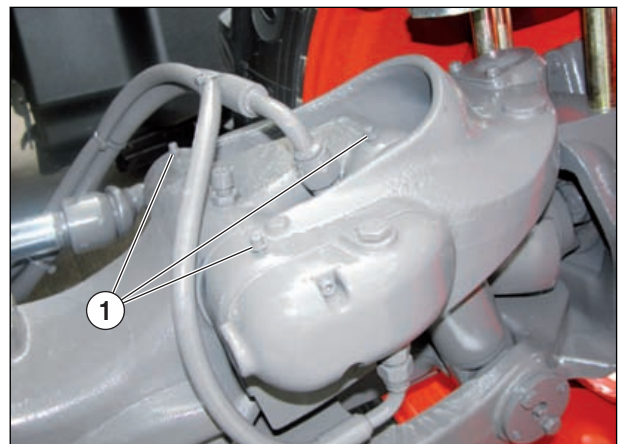
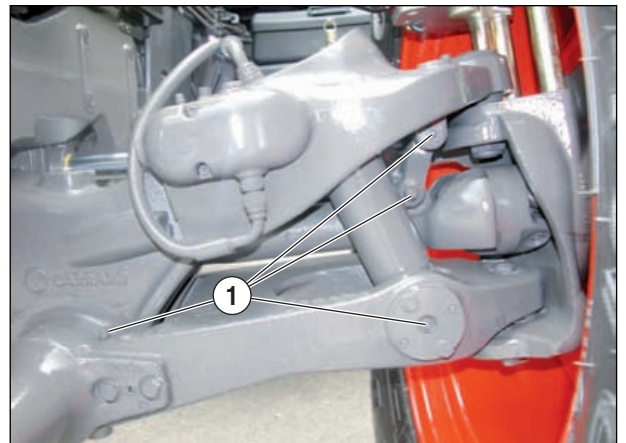
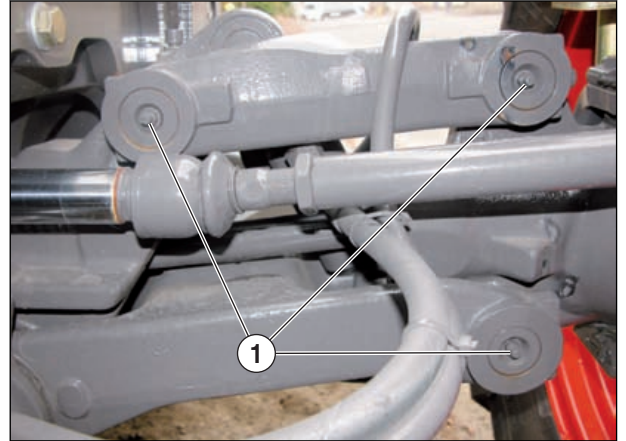



9.2.41 Operation n° 41

4026

Replace: Front power take-off box oil

- Position the tractor on a flat horizontal surface.
- Place a suitable container under the box.
- To drain, disconnect the coolant pipe by loosening the screw of coupling (1).
- Once the oil is drained completely, connect the coolant pipe by tightening the screw in coupling (1).

Note: Dispose of collected oil and used filters in accordance with currently enforced regulations

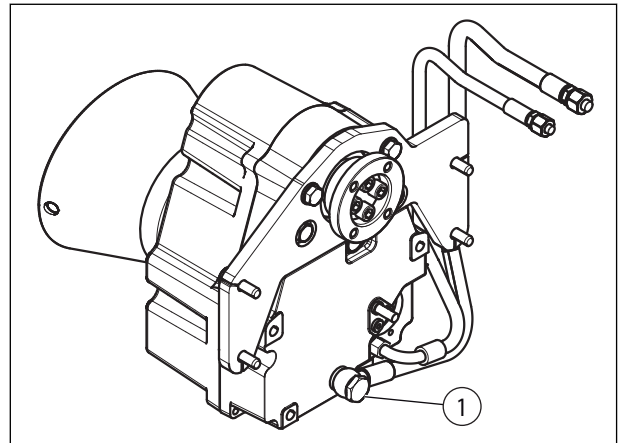

421hsn01r

- Remove the circlip (1) and the cover (2)
- Remove the filter.
- Refit the new filter .
- Reinstall the cover (2).
- Refit the circlip (1).

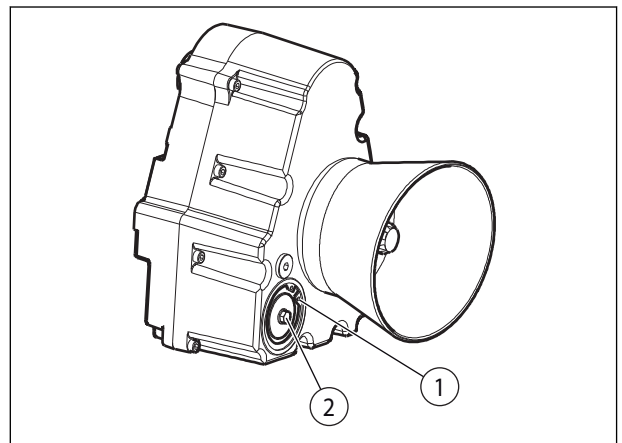

421hsn04r

- Fill via the plug (1) as shown in operation "Checking PTO gearbox oil level".

Important: When topping up the oil, observe specifications in terms of oil grade.

- Start the engine and let it run for a few minutes.
- Top up the fluid level.
- Start the engine and let it run for a few minutes.
- Check the oil level and top up if required.

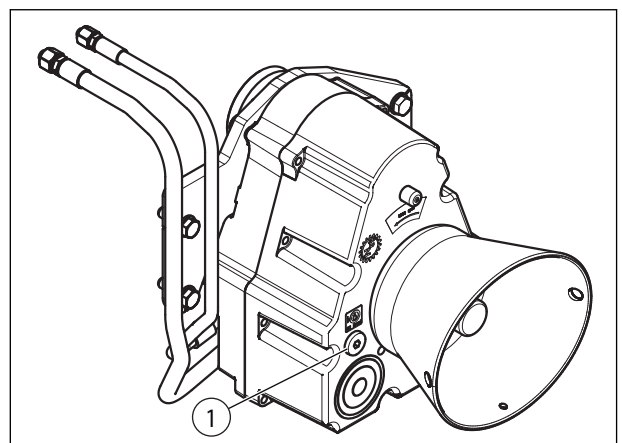

421hsn03r

9.2.42 Operation n° 42

6406

Check: Clevis gap

Important: This operation must be performed by a CLAAS approved workshop.



Important: Use only original filters

- Open the lid (1).



621hsn02

- Undo nut (1).
- Remove the prefilter strap (2).

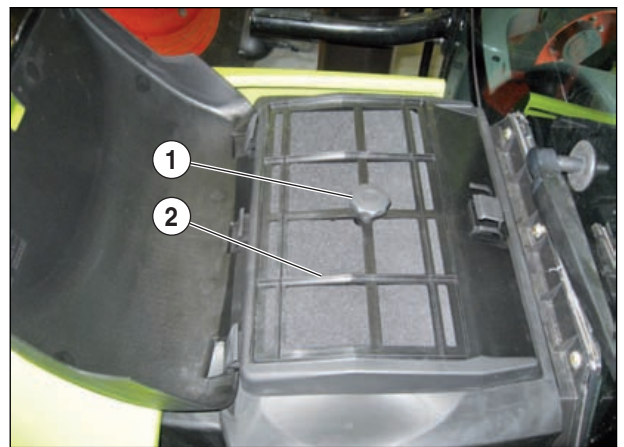

621hsn03

- Remove the prefilter (1).



621hsn04

CLICK HERE TO **DOWNLOAD** THE COMPLETE MANUAL

- Thank you very much for reading the preview of the manual.
- You can download the complete manual from: www.heydownloads.com by clicking the link below



- Please note: If there is no response to CLICKING the link, please download this PDF first and then click on it.

CLICK HERE TO **DOWNLOAD** THE COMPLETE MANUAL