

Operator's Manual

Challenger[®]

Application System

Air Spreader

AGCCAS00.G...1001-



North America

4205 River Green Parkway, Duluth GA 30096 USA
Challenger is a registered trademark of Caterpillar
Inc. and is used under license by AGCO.

© AGCO 2015

Original Operator's Manual

May 2015

590952D1A

NA

English

CLICK HERE TO **DOWNLOAD** THE COMPLETE MANUAL

- Thank you very much for reading the preview of the manual.
- You can download the complete manual from: www.heydownloads.com by clicking the link below



- Please note: If there is no response to CLICKING the link, please download this PDF first and then click on it.

CLICK HERE TO **DOWNLOAD** THE COMPLETE MANUAL

1.1.4 Follow safety instructions

Carefully read, learn and understand all safety messages and or information in this manual and on machine's safety signs. Keep safety signs in good condition. Replace missing or damaged safety signs. Make sure the new equipment components and or repair parts include current safety signs. See local dealer for replacement safety signs.

Never operate machine or equipment without correct instruction and a complete understanding of control operation.

Learn to operate the machine and how to use all controls correctly before operation. Do not let operator's not authorized operate the machine, systems and or do service and or maintenance procedures without correct instruction.

Keep machine, all components and systems, in correct working condition. Modifications to the machine not authorized by AGCO can decrease functionality and or safety, decrease machine life and void machine warranty.

IMPORTANT: *Any modifications to machine or systems not authorized by AGCO void the warranty.*



Fig. 4

1.1.5 Prepare for emergencies

Keep a first aid kit and a fire extinguisher handy. Keep emergency numbers for doctors, ambulance service, hospital, and the fire department readily available always.

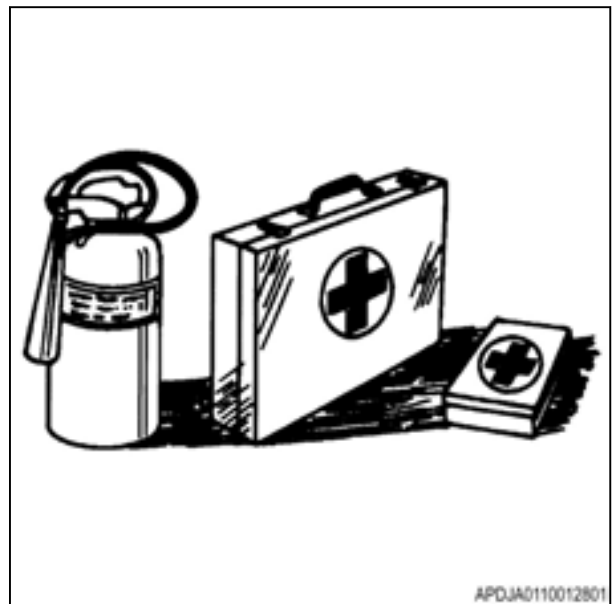

Fig. 5

Never apply chemicals when the wind exceeds the chemical manufacturer's recommendation. NEVER let chemicals touch the skin or eyes.



Fig. 23

1.3.4 Work in a clean area

Thoroughly clean work area, machine, systems, and components before starting work. Dirty and greasy areas can create work hazards.

NOTE:

Let the work lights cool for ten minutes after operation before washing.



Fig. 24

2. Introduction

2.1 Introduction	33
2.1.1 Intended use	33
2.1.2 Proper disposal of waste	33
2.1.3 Pre-delivery checklist	33
2.2 Serial number	34
2.2.1 System serial number	34
2.2.2 Serial number definition	34

3.1.4 Air spreader gauges

- (1) Air pressure gauge - displays air pressure in the foam marker tank. The air pressure gauge will show approximately 205 kPa (30 psi) during normal operation.
- (2) Air pressure control knob - Turn the air pressure control knob to increase or decrease pressure.

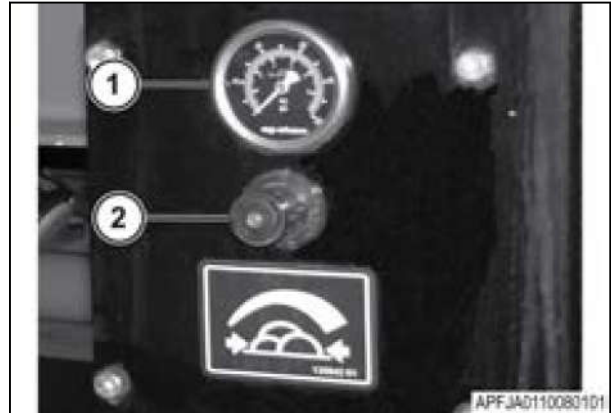

Fig. 6 Air pressure gauge

The hydraulic pressure gauges are located on the front of the hopper.

- (1) The hydraulic pressure gauge displays the pressure in the conveyor / auger circuit.
- (2) The hydraulic pressure gauge displays the pressure in the blower fan circuit.



WARNING:

Do not operate the system if the pressure is more than 241 bar (3500 psi). Do not operate the conveyor / auger circuit at more than 172 bar (2500 psi). Do not tamper with the relief valve settings. Personal injury or death can occur.

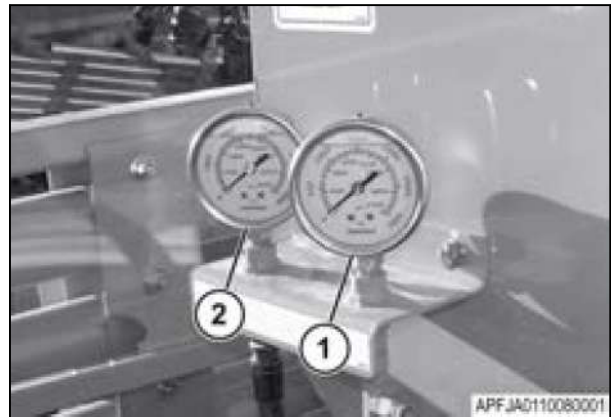

Fig. 7 Hydraulic pressure gauge

Hydraulic temperature gauge

IMPORTANT: *The hydraulic oil temperature must be 27 degrees C (80 degrees F) minimum before operating the system.*

IMPORTANT: *Do not operate the system if the temperature exceeds 93 degrees C (200 degrees F). High oil temperature may indicate debris on the oil coolers.*

Normal operating temperatures range from 49-88 degrees C (120-190 degrees F).



Fig. 8 Hydraulic temperature gauge

3. Switch off the system hydraulic/electric lockout switch.
4. Fill the hopper box with twice the amount of material required to calibrate application, 363 kg (800 lb).

NOTE: Based on the procedure, use the largest container available as this can limit the application quantity.



Fig. 24

5. Do a density check on the material using a density scale (1).
6. Enter the information into the controller.

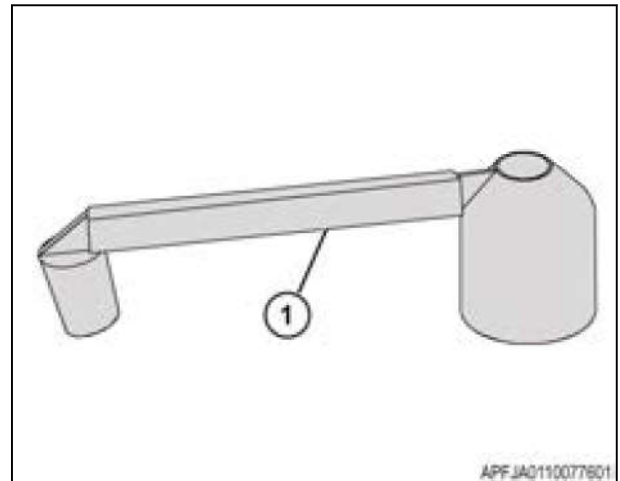

Fig. 25

7. Push in the knob to turn off the vertical auger (1).
8. Open the horizontal auger clean-out door (2).

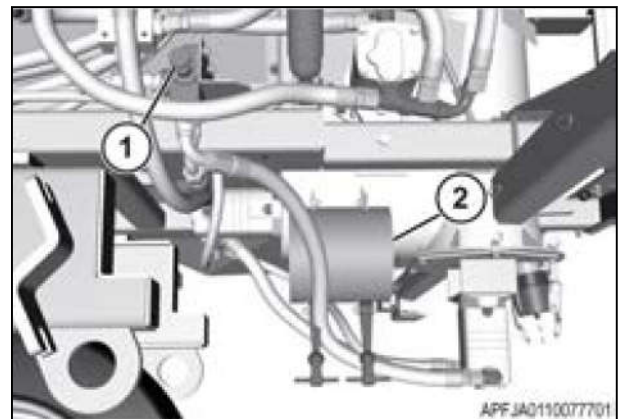

Fig. 26

9. Set the gate height (1).

Approximate application rate (lbs/acre)				
		70 foot spread width		
Gate height (inches)	Spreader constant	10 mph	15 mph	20 mph
1	2880	29-477	19-318	14-238
1.5	1920	43-715	29-477	22-358
2	1440	57-593	38-635	29-477
2.5	1152	72-1000	48-667	36-500

CLICK HERE TO **DOWNLOAD** THE COMPLETE MANUAL

- Thank you very much for reading the preview of the manual.
- You can download the complete manual from: www.heydownloads.com by clicking the link below



- Please note: If there is no response to CLICKING the link, please download this PDF first and then click on it.

CLICK HERE TO **DOWNLOAD** THE COMPLETE MANUAL

3.6.4 Granular metering system description

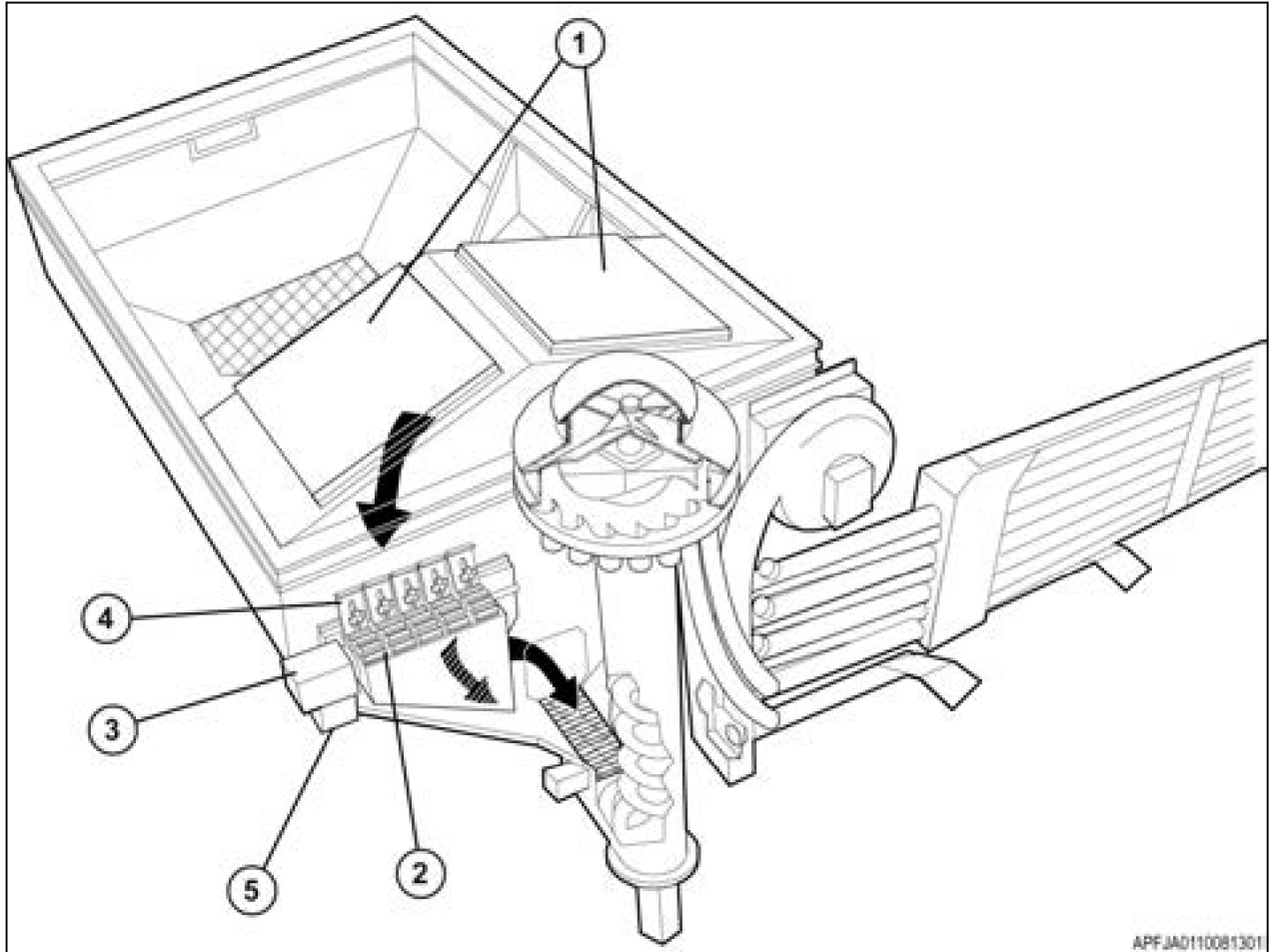

Fig. 40

- 1 Granular bin hoppers
- 2 Metering wheels
- 3 Electric motor
- 4 Shut-off doors
- 5 Motor driver with manual override

There are two separate granular metering systems. Each system contains five pairs of metering wheels, metering cups, shut-off doors and a drive shaft.

A 12 volt motor through a sealed gear reducer drives each metering assembly.

There are two metering wheel selections for each system:

- High rate (yellow) metering wheels deliver 2.27 kg (5 lb) per acre to 18.14 kg (40 lb) per acre.
- Low rate (black) metering wheels deliver 0.9 kg (2 lb) per acre to 4.5 kg (10 lb) per acre.

3.6.5 Hoppers

Two stainless steel hoppers bolt into a standard air spreader hopper. Each hopper contains a 0.7 m³ (25 ft³) volume. The hoppers raise the box height by 32 cm (5 in) and reduce the box capacity by 0.7 m³ (25 ft³). The hoppers have a cover and lid openings for filling and cleaning. Screens inside each hopper collect foreign material.

4. Maintenance

4.1 Granular metering system maintenance	73
4.1.1 Cleaning the granular metering system	73
4.1.2 Lubrication of the granular metering system	73
4.2 Liquid system maintenance	74
4.2.1 Flushing the system	74
4.2.2 Cleaning the boom strainer	74
4.2.3 Checking the hoses	75
4.2.4 Storing the application system	75
4.3 Maintenance schedule	77
4.3.1 Lubricant filling reminders	78
4.3.2 Welding on the machine	78
4.4 Hydraulic system maintenance	79
4.4.1 Hydraulic system	79
4.4.2 Checking the hydraulic system	79
4.4.3 Medium pressure filter location	80
4.4.4 Checking the oil filter condition indicator	80
4.4.5 Replacing the hydraulic oil	80
4.5 Conveyor maintenance	82
4.5.1 Lubricating the conveyor bearings	82
4.5.2 Adjusting the conveyor chain tension	82
4.6 Boom maintenance	84
4.6.1 Lubricating the boom pivots	84
4.7 Vertical auger bearing	86
4.7.1 Lubricating the vertical auger bearing	86
4.8 Application system storage	87
4.8.1 Preparing the application system for storage	87
4.8.2 Winterizing the foam marker	87
4.9 Application system removal and installation	88
4.9.1 Spreader box lifting points	88
4.9.2 Removing the Air Spreader system	88
4.9.3 Installing the Air Spreader system	93
4.9.4 Removing the coapplication system	97
4.9.5 Installing the coapplication system	102

6. Remove the drain plug from the bottom of the hydraulic reservoir. Drain the hydraulic oil into a correct container.
7. Remove the hydraulic oil filter element. Drain the hydraulic oil into a correct container.
8. Clean the surface of the filter head. Fill the filter element with new hydraulic oil. Apply oil to the rubber gasket on the new filter element. Install the filter element.
9. Install the drain plug in the bottom of the hydraulic reservoir. Fill the hydraulic reservoir with hydraulic/transmission oil such as AGCO Permatran 821 XL. Install the hydraulic reservoir filler cap. Make sure the hydraulic gate valve in the pump suction line is open.
10. Check the hydraulic oil level in the hydraulic reservoir and add if necessary.
11. Start the engine and operate at idle only.
12. Increase the fan control.
13. During five minutes of fan operation, run the conveyor hydraulic motor. Operate the vertical auger motor selector valve.
14. If the system is operating smoothly and quietly, increase the engine speed until you reach approximately 15 858 kPa (2300 psi) hydraulic pressure. The hydraulic pressure and fan speeds will stop increasing at this point.

16. Disconnect the hydraulic hoses (1) from the hydraulic pump. Plug the ports and cap the hoses.

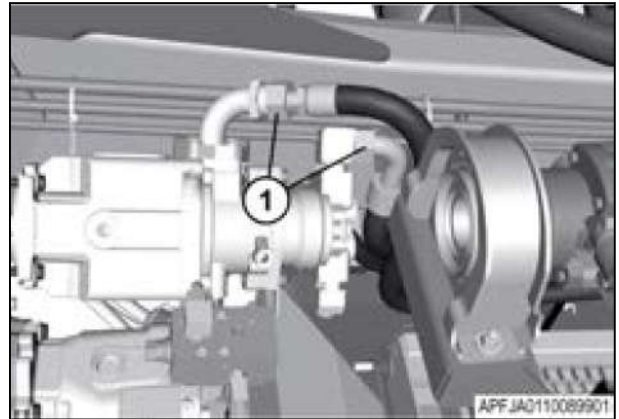

Fig. 22

17. Close the hydraulic reservoir valve (1). Disconnect the hydraulic hoses (2). Plug the ports and cap the hoses.

NOTE:

The hydraulic reservoir valve is shown in the open position.

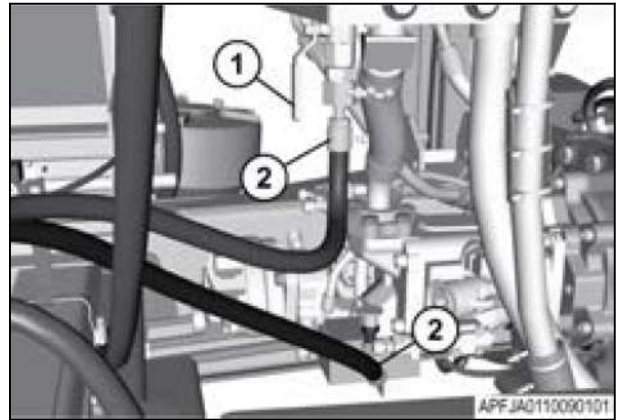

Fig. 23

18. Remove the hardware (1) and the hydraulic pump (2) from the transmission.

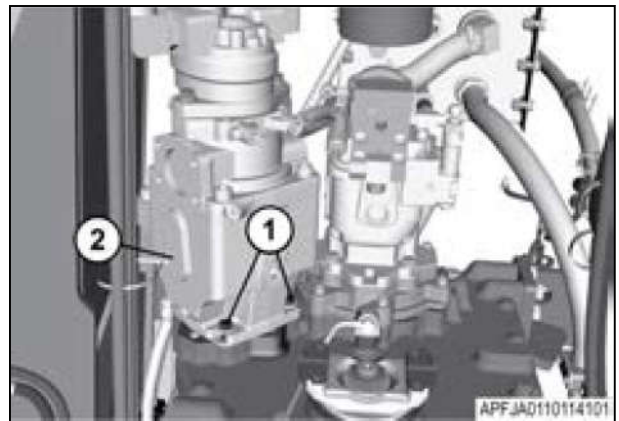

Fig. 24

14. Remove the hardware (1) and the tank guard (2). Repeat the step for the opposite side tank.

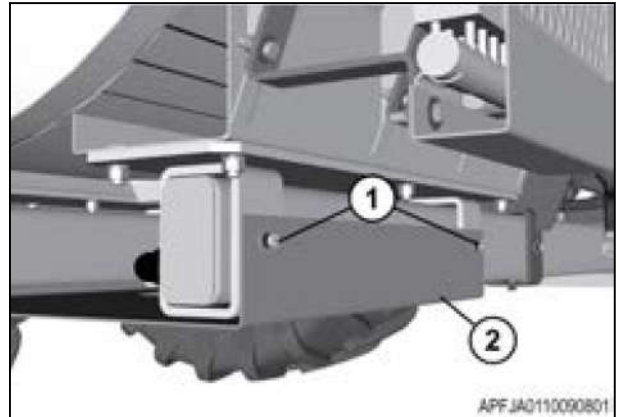

Fig. 49

15. Fasten the correct lifting equipment to the saddle tank assembly (1). Remove the saddle tank assembly. Repeat the step for the opposite side tank.

IMPORTANT:

The saddle tank weighs approximately 186 kg (411 lb).

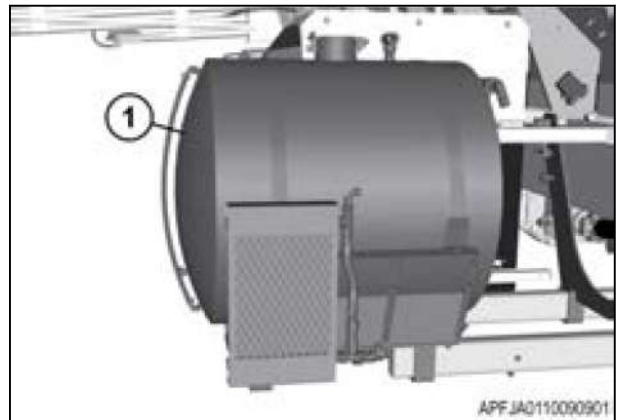

Fig. 50

16. Support the cross tube assembly (1) with the correct lifting equipment.

IMPORTANT:

The cross tube assembly weighs approximately 166 kg (363 lb).

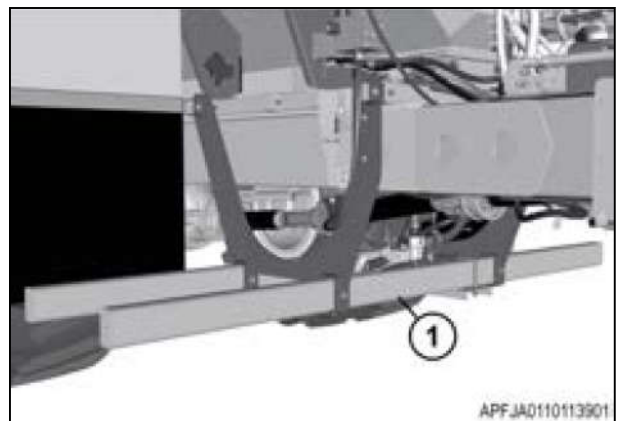

Fig. 51

5.1 Application system troubleshooting

Symptom	Cause(s)	Solution(s)
Vertical auger, charger auger and conveyor motor do not operate.	Plugged valve or faulty coil at the vertical auger solenoid.	Repair or replace the relief valve.
	Loose wire or connector.	Connect the wire / connector.
	Vertical auger is plugged	Turn the engine off. Remove the obstruction from the vertical auger.
Vertical auger, charger auger and conveyor operate slowly or stop when applying material. Augers appear to be operating normally without product in the hopper.	The solenoid relief valve connected at the inlet of the selector valve has foreign material in the valve seat and is bypassing oil.	Check the relief valve setting. Clean or repair the relief valve so it can seat properly or replace the relief valve cartridge.
	Defective / partially plugged 18 gpm flow regulator.	Adjust the relief valve to 172.4 bar (2500 psi) if necessary.
		Clean or replace the flow regulator.
Hydraulic (product delivery) system operates between 62 bar 900 psi - 97 bar (1400 psi) at engine idle with low fan speed(100-600 RPM). (The system must operate at 34 bar (500 psi) or less with a hydraulic oil operating temperature of 38 °C (100 °F) or more).	Charge auger is plugged.	Turn the engine off. Remove the obstruction from the charge auger.
	Vertical auger is plugged.	Turn the engine off. Remove the obstruction from the vertical auger.
	Charge or vertical auger motor is damaged.	Replace the damaged motor.
	Conveyor hydraulic motor or conveyor chain will not turn or move.	Repair or replace the conveyor hydraulic motor.
		Repair the conveyor chain or hopper.
The maximum hydraulic operating pressure is 69 bar (1000 psi) - 103 bar (1500 psi), the fan RPM and auger RPM are low at full engine RPM.	Hydraulic suction line has a partially closed gate valve.	Open the gate valve.
	Hydraulic oil is not at the proper operating temperature.	Run the hydraulic system with the fan control valve wide open and engine at 1000 RPM or above until the oil temperature is 38 °C (100 °F) or the hydraulic pressure comes up to 155 bar (2250 psi).
	Worn or damaged hydraulic pump.	Contact AGCO or an authorized service center for the pump repair or replacement.
The hydraulic pressure is 172 bar (2500 psi) or more at all engine speeds, neither the fans nor the augers rotate and the fan tachometer is blank.	The fan will not move in its housing.	Free the fan so it rotates freely or replace the fan if damaged.
	The fan hydraulic motor(s) is damaged, seized or has a foreign object in the motor.	Repair or replace the motor(s).
The fan speed response is slow.	The in-line filter between the pump pressure sense valve and the fan	Remove the in-line filter and back flush to clean.

CLICK HERE TO **DOWNLOAD** THE COMPLETE MANUAL

- Thank you very much for reading the preview of the manual.
- You can download the complete manual from: www.heydownloads.com by clicking the link below



- Please note: If there is no response to CLICKING the link, please download this PDF first and then click on it.

CLICK HERE TO **DOWNLOAD** THE COMPLETE MANUAL