



295HR MINING SHOVEL OPERATOR'S MANUAL

SN:141346

SN:141347

SN:141350

SN:141351

Manual No. **10710**

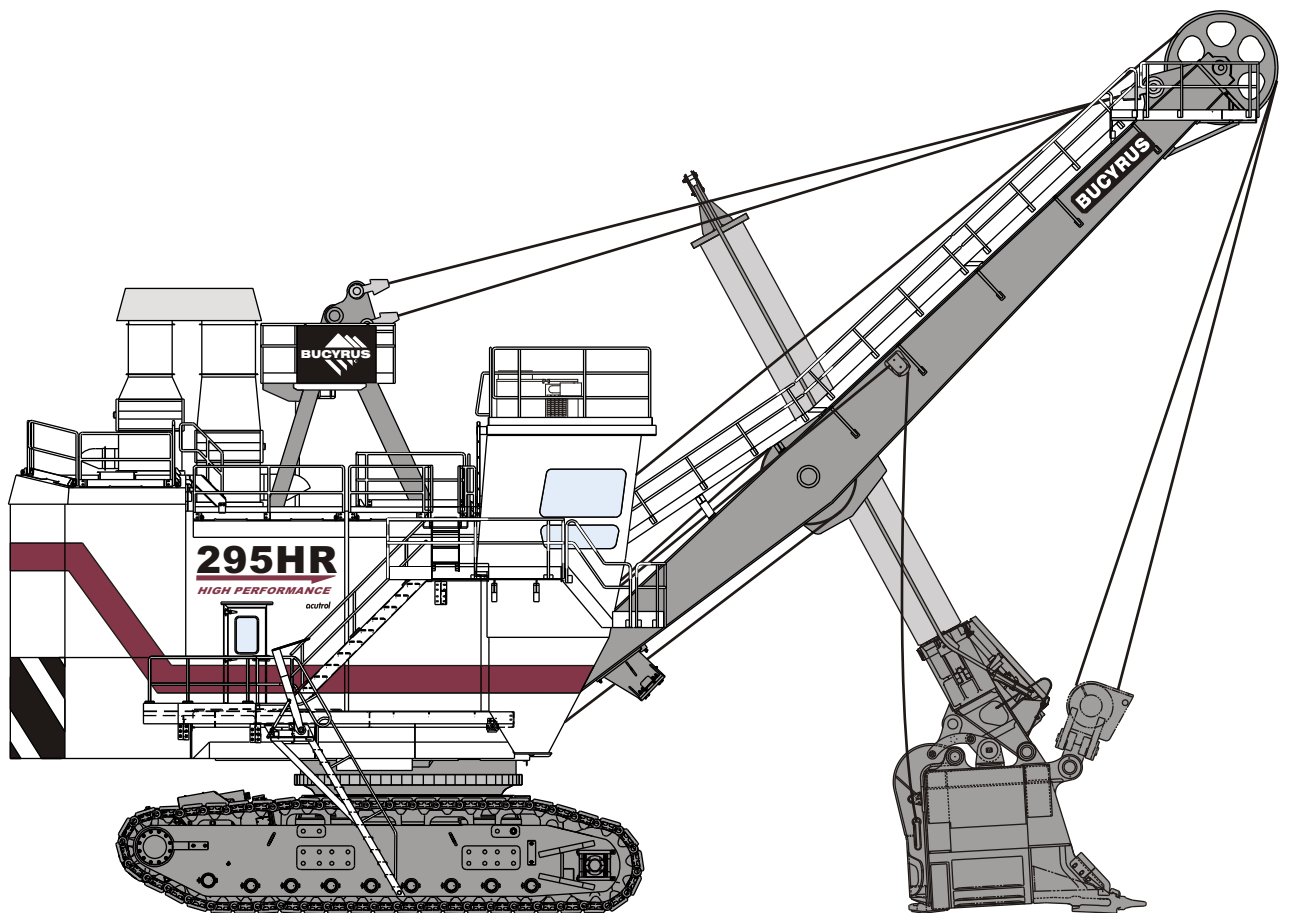

141346mc.cdr Pg.2

Bucyrus International, Inc.

1100 Milwaukee Ave. • P.O.Box 500 • South Milwaukee, Wisconsin 53172-0500 USA

CLICK HERE TO **DOWNLOAD** THE COMPLETE MANUAL

- Thank you very much for reading the preview of the manual.
- You can download the complete manual from: www.heydownloads.com by clicking the link below



- Please note: If there is no response to CLICKING the link, please download this PDF first and then click on it.

CLICK HERE TO **DOWNLOAD** THE COMPLETE MANUAL



SAFETY - SWINGING RESTRAINT & BALLAST BOX SUPPORT

BALLAST BOX SUPPORT

Before performing any maintenance on the mining shovel, it should be resting on a firm, level surface.

Any mining shovel field work that requires the removal or lowering of the boom must incorporate additional support of the ballast box. The supports may be wooden cribbing or steel structures. Two supports positioned side-by-side on level ground are recommended. These supports are intended to accept vertical loads only. To prevent machine rotation use the swing brakes, cable stays, welded ties, etc. Refer to "SWING RESTRAINT".

When electric-powered, cable-style mining shovels are properly ballasted and operational, the center of gravity for the machine's upper works lies within the roller circle area. This assumes that the boom is attached to the machine and in its elevated, working position. As such, the machine should not be prone to tipping.

Boom removal or lowering will cause the center of gravity to shift toward the ballast box, decreasing machine stability. Stability is further dependent on the orientation of the upper works relative to the undercarriage. The machine may tip more easily over one of the four quadrants of the crawler mounting than it may over others.

Normally the machine is more likely to tip over the rear-most lower-roller than over the side of a crawler. Therefore, with the boom removed and the ballast box sitting over the rear of the crawlers, the machine may be unstable. Because ballast quantities differ from machine to machine and model to model, it is recommended that the ballast box be supported *before* beginning any procedure to lower and/or remove the boom.

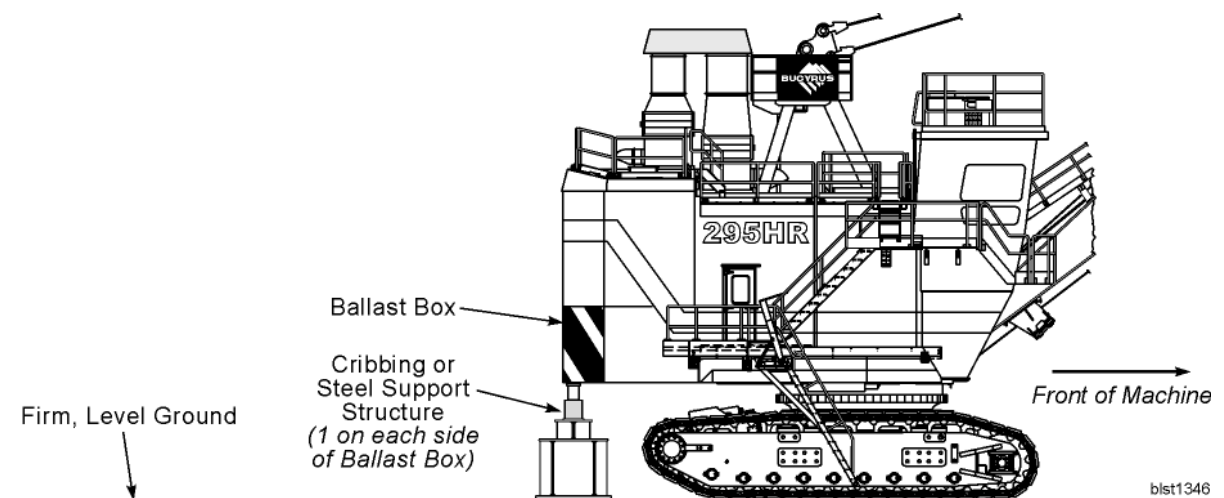



LOWER WORKS

The lower works is comprised of the truck frame, right and left crawler frames, crawler belts, propel machinery, swing rack and roller circle.

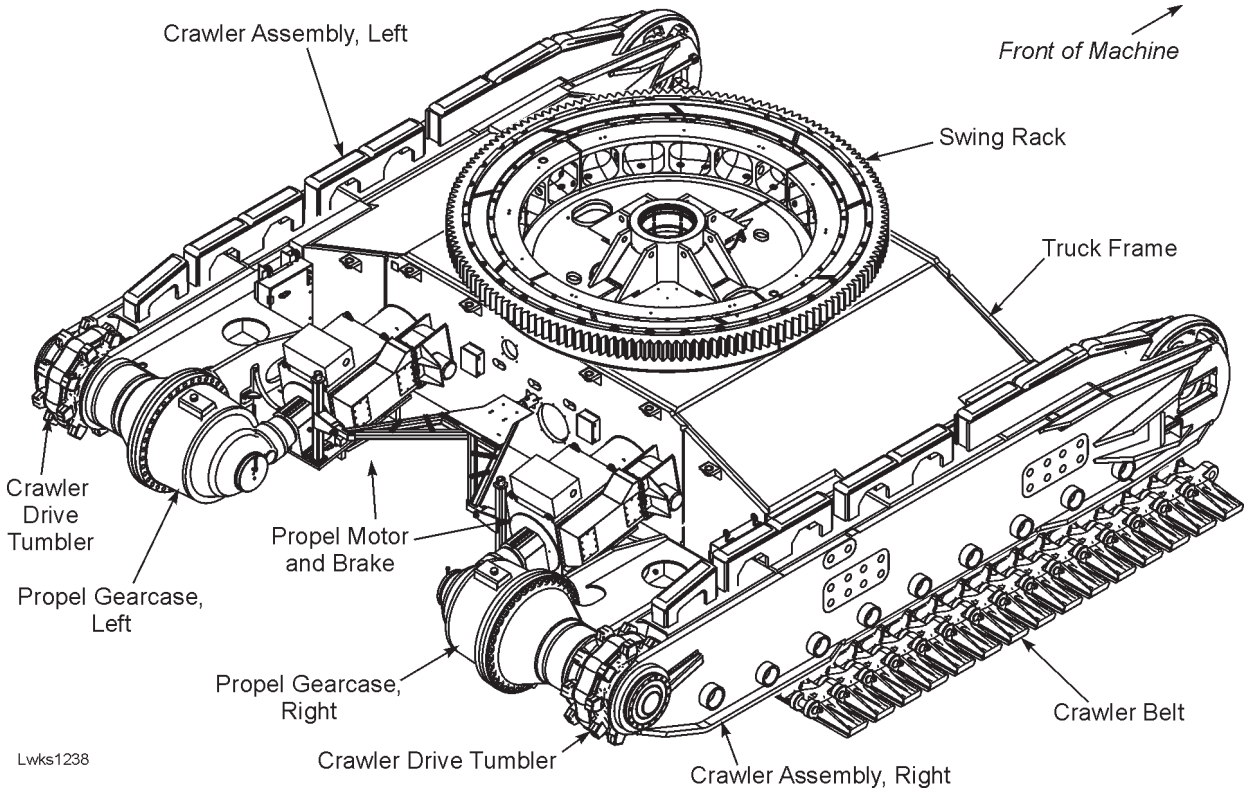

Lwks1238

Truck Frame and Crawlers



MACHINERY HOUSE

The machinery house encloses the revolving frame, ballast box and deck extensions. It is constructed of self-supporting steel panels with built-in framing. Removable roof sections are provided over the swing machinery and to the side and rear of the A-frame. The house also provides mounting for the air ventilation and pressurization system. A separate electrical room is located over the ballast box. Platforms and stairs facilitate access to the sides and tops of the house for inspection and maintenance purposes. Boarding stairs permit easy access onto the machine.

BOARDING STAIRS

A set of boarding stairs is attached to the machinery house platform on the right side of the machine. When lowered, the stairs allow entrance to the machinery house from ground level. To lower the stairs, a chord attached to the stairway is reachable from the ground. The stairs must be in the raised position to enable the operator's controls.

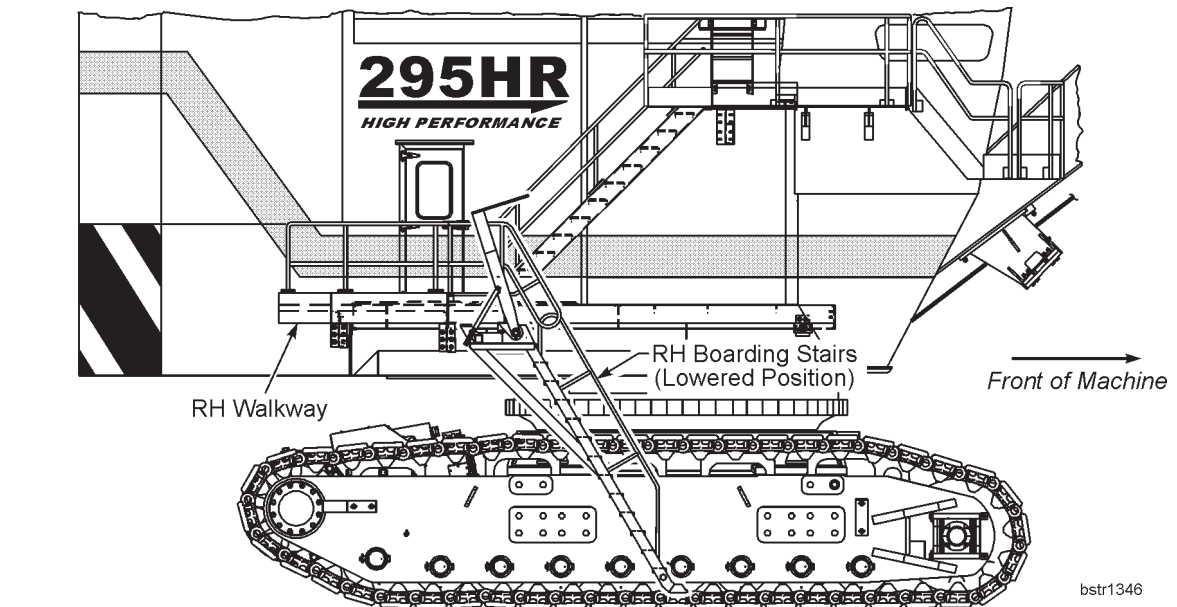

RH Boarding Stairs



FRONT END EQUIPMENT

The front end equipment consists of the boom, the boom point sheaves, padlock, saddle block, dipper handle, dipper, dipper trip mechanisms, running ropes and boom suspension strands.

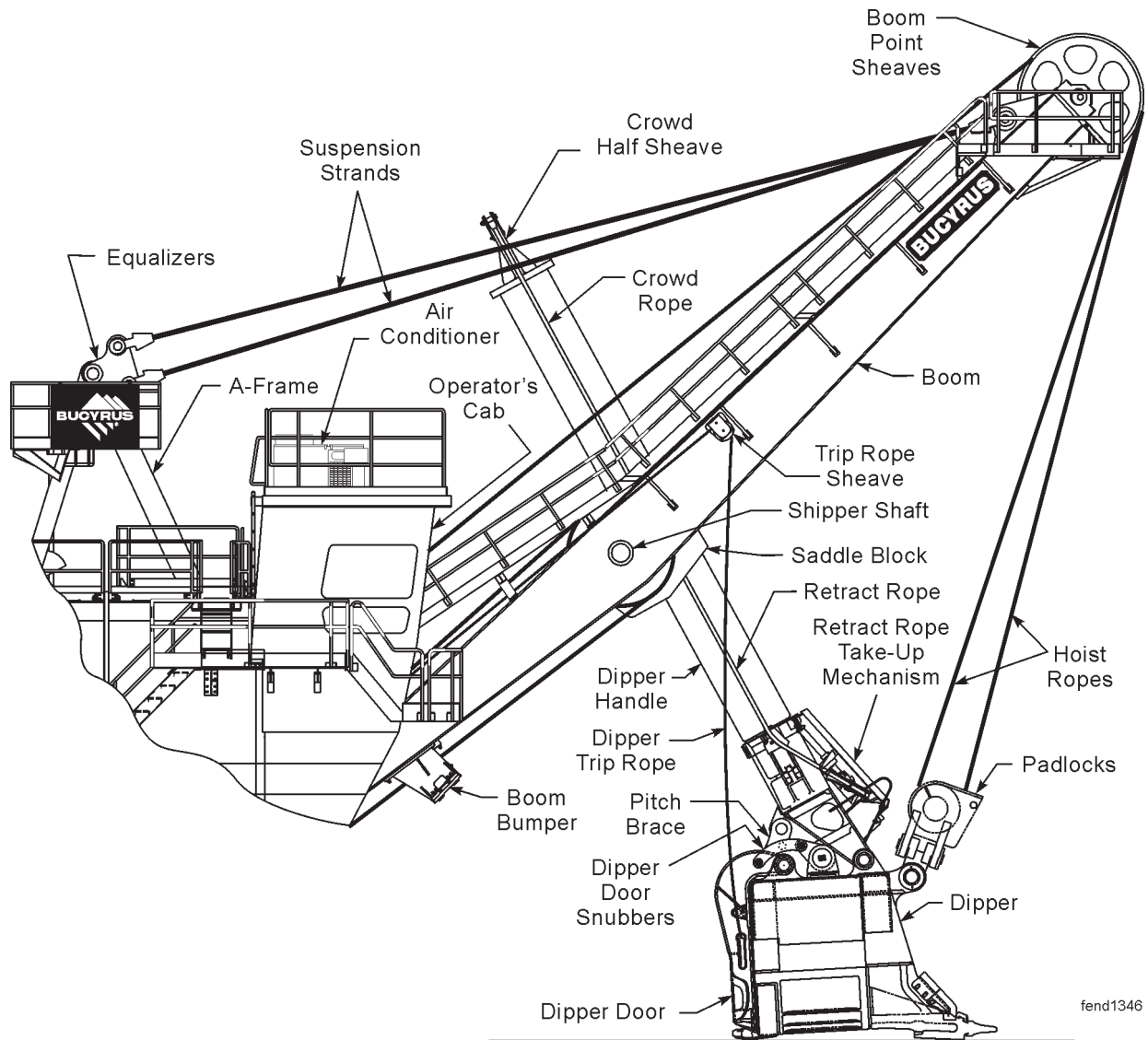

fend1346

SUSPENSION STRANDS

The suspension strands are designed to maintain the proper boom angle. These are fixed-length strands that support the entire weight of the boom and the load.



CONTROLS ON THE LEFT CONSOLE

LEFT JOYSTICK

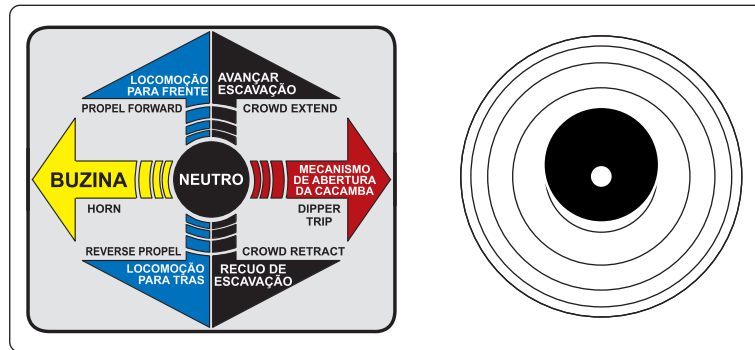

omsL1346

The Left Joystick controls the crowd/horn/dipper trip and propel. It is the vertical handle mounted on the left console of the operator's seat. This joystick will spring return to neutral when released.

During normal operation, pushing the joystick forward will extend the dipper handle and dipper into the bank. Pulling the joystick rearward will retract the dipper handle and dipper toward the machine. The neutral position between the crowd and retract functions is defined by a detent that is easily felt. The rate of motion is controlled by varying the distance the joystick is moved from the neutral (center) position. Full forward or full rearward position provides maximum speed to the handle. Moving the joystick to neutral will cause a braking action slowing the crowding or retracting handle. Reversing the joystick will cause the motion to stop and if the joystick is held in this position, it will change the direction of the motion.

With the propel transfer switch in the PROPEL position, pushing the joystick forward will cause the left crawler to move forward. Pulling the joystick to the rear will cause the left crawler to move in the reverse direction. The crowd/retract motion is locked out electrically when the machine is in the propel mode.

Refer to JOYSTICK CONFIGURATION in this section of the manual to view the standard and alternate configurations for the Right and Left Joysticks.

DIPPER TRIP

The dipper trip is part of the left joystick function in the standard configuration. Moving the joystick to the right will activate the dipper trip mechanism which releases the dipper door latch. The dipper trip is operational throughout the entire range of the crowd motion.

SIGNAL HORN

Moving the Left Joystick (in the standard configuration) to the left will activate the signal horn. The signal horn is operational throughout the entire movement range of the crowd motion.

RADIO

The radio supplied with your machine is an AM/FM Stereo radio with cassette player.



295HR Electric Mining Shovel

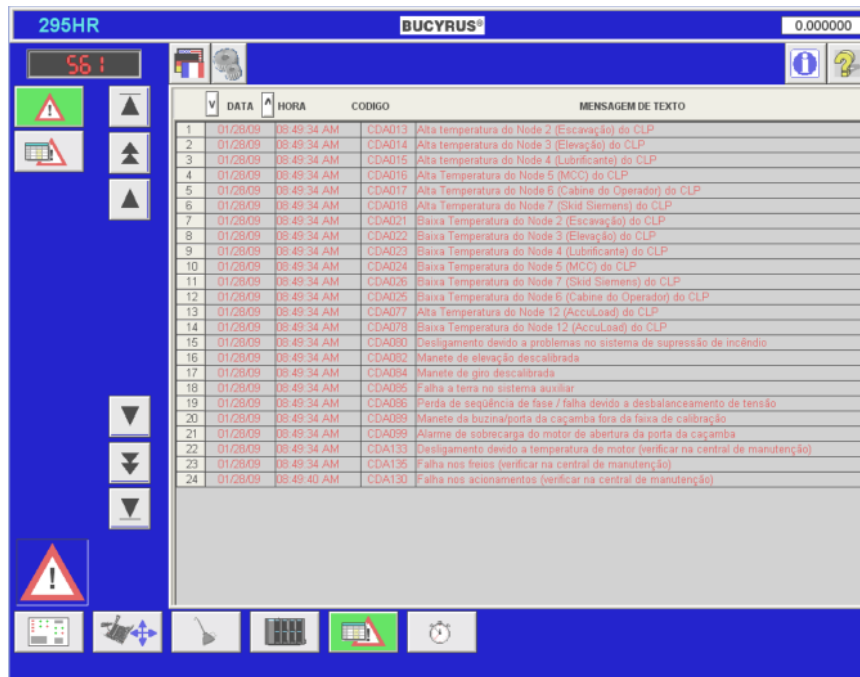

S-AA_295HR

Active Alarm

The Active Alarm screen will provide a list of all active alarms and faults that have been initiated on the machine and have not been RESET. Once an alarm or fault has been sensed, these messages will remain visible and WILL NOT be removed from this screen until it is RESET.

When a new alarm occurs, it shows up in a separate window on the top of any screen. It is cleared when there are no active alarms, the user goes to one of the other alarm screens, or the user presses the X next to the line.

NOTE: It is important to remember that messages will appear in this screen that are no longer active alarm messages. All messages will appear since the time of the last reset.



WINDSHIELD WIPERS

There are two electrically operated windshield wipers on the front window of the cab: one for the lower portion of the window and one for the upper portion of the window.

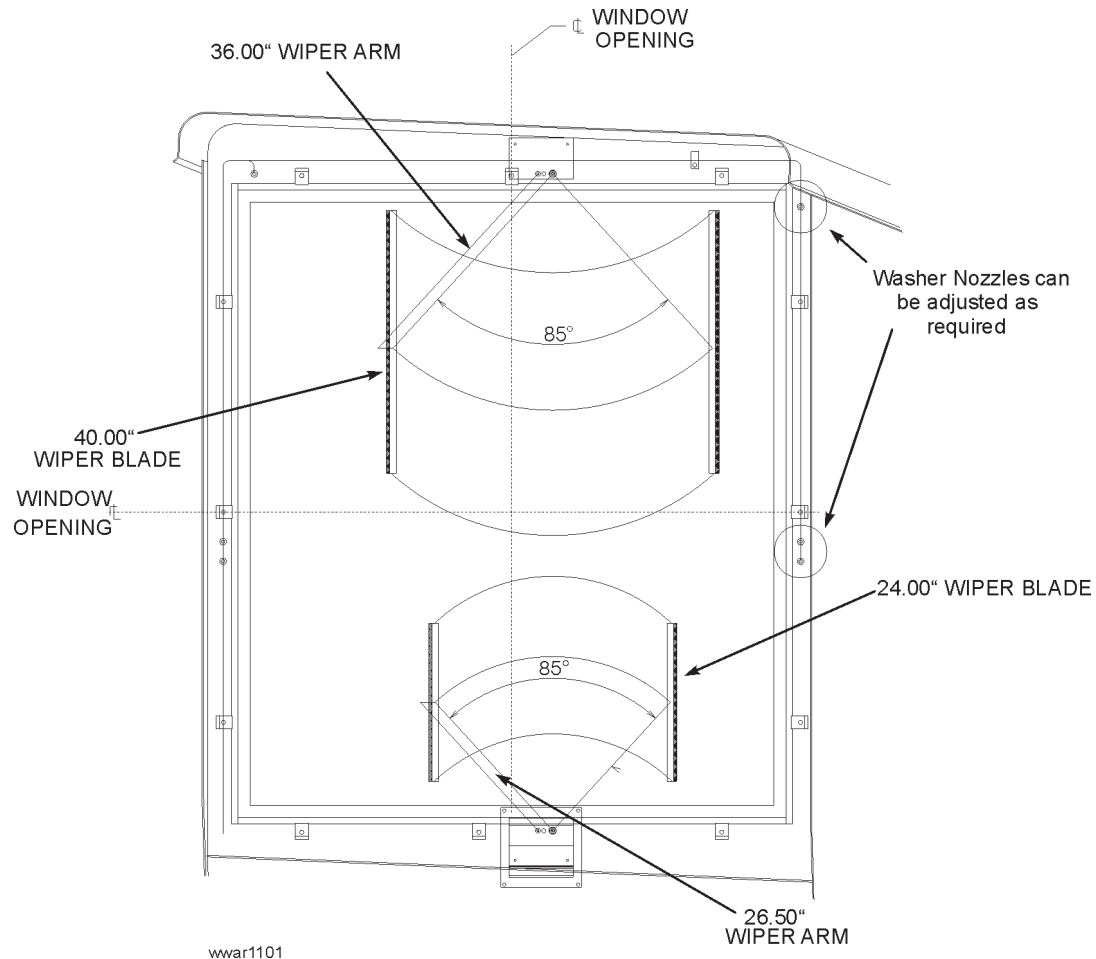

Check the wiper blades to make sure they swing freely across the window without contacting the window frame. Reposition the pantograph arm on the wiper motor shaft if necessary to prevent contact with the window frame.

Frequently check the condition of the wiper blades and replace if damaged.

WINDSHIELD WASHER

An optional electric operated windshield washer unit supplies a cleaning agent to the windshield through spray nozzles when activated. When operating in warm climates, water may be used as the agent. In areas where freezing temperatures are encountered, a suitable commercial windshield washer solvent with anti-freezing characteristics is recommended.



SWING MOTION

In standard configuration, Swing motion is controlled by the operator's right joystick. To swing in either direction, move the joystick lever in the direction of swing. Practice swinging in each direction until a "feel" is developed for start-up and stopping.

NOTE: The joy stick also controls the hoisting and lowering of the dipper through forward and backward motions.



DANGER: Each motion - hoist or swing - is fully operational throughout the complete movement of the other motion.

NOTE: When this joystick is used for propelling the machine, the hoist and swing motions are electrically locked out.

NOTE: The following represents the standard configuration.

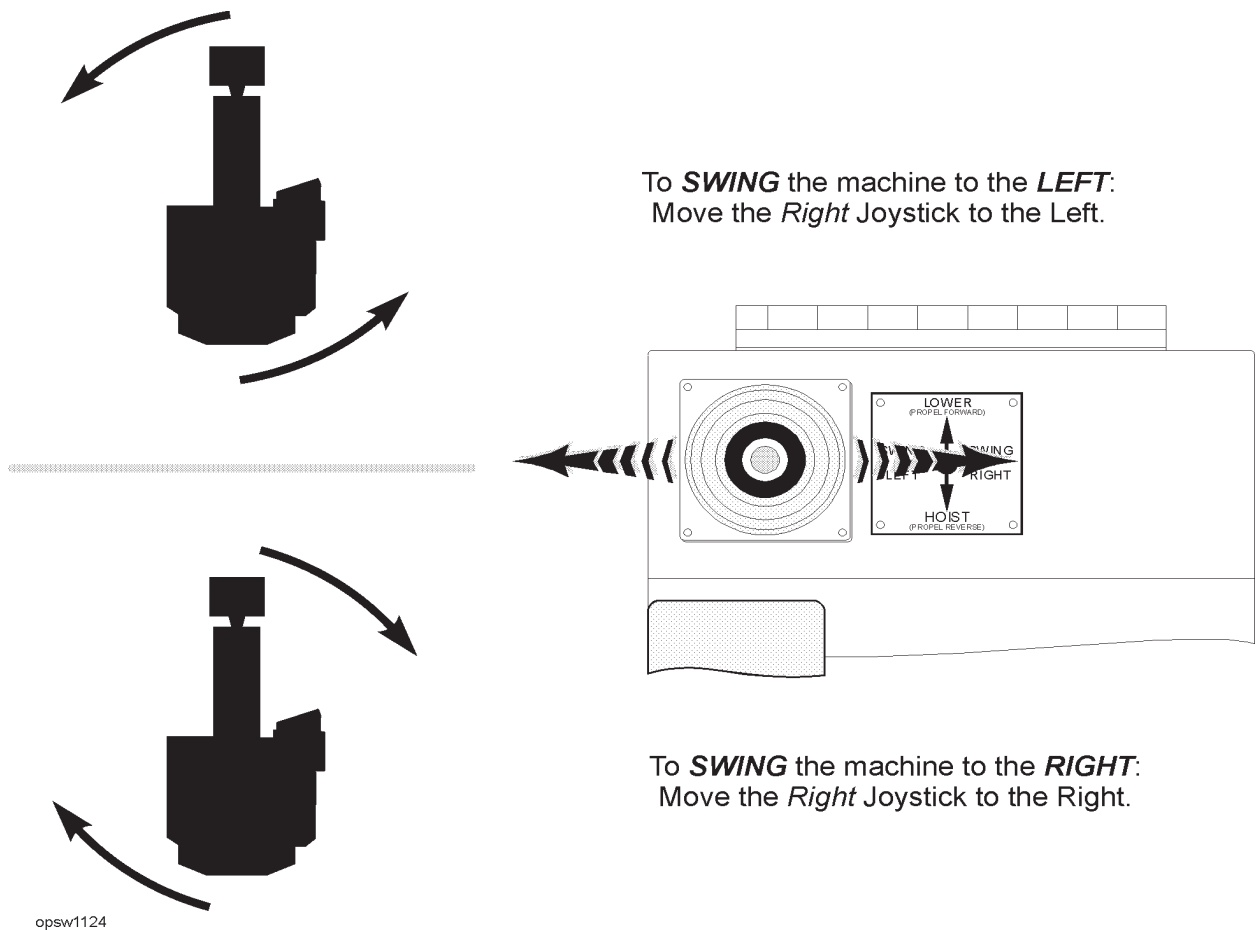

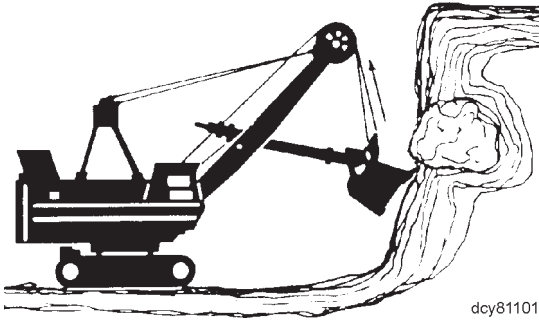

dcy81101

In all types of digging the skilled operator must carefully control the desired depth of cut and control the hoist power requirements. Often, digging situations are encountered which require hoist and crowd motions to maneuver around oversize or lodged obstructions in the bank, rather than attempting to lift the entire bank.



DANGER: MAINTAIN A DIGGING FACE WHICH AVOIDS ANY MAJOR SLIDES WHICH COULD CAUSE AN ACCIDENT. Examine the digging face for large boulders, large rocks, or frozen material which could slide and cause an accident. Avoid overhanging material.

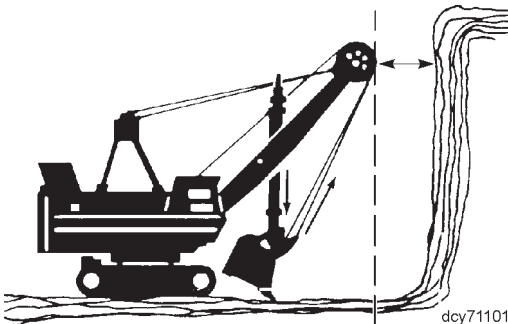

dcy71101

Do not repeatedly stall the dipper in the bank, nor maintain a stall condition. The life expectancy of the hoist machinery and hoist ropes is directly related to the operator's skill in avoiding stalling. Whenever stall conditions are encountered, back off on the hoist motion, retract the dipper, or do both. Avoid stall conditions at all times.



DANGER: DO NOT SUSPEND A LOADED OR EMPTY DIPPER IN THE AIR WITH THE BRAKES SET FOR LONG TIME PERIODS. Lower the dipper to the ground if the machine is to be idle or unattended for any length of time. Failure to comply can result in personal injury or death of anyone beneath the dipper.

For most efficient production, the dipper should be loaded from the most remote point while waiting for a truck. When the truck is positioned, excavating should begin close to the haulage unit, progressively working away from the unit.

This technique saves time by allowing smooth, short dig cycles and eliminates excessive swing, crowd and retract motions.

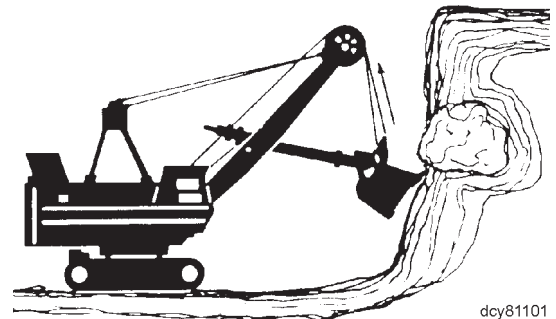

dcy81101

CLICK HERE TO **DOWNLOAD** THE COMPLETE MANUAL

- Thank you very much for reading the preview of the manual.
- You can download the complete manual from: www.heydownloads.com by clicking the link below



- Please note: If there is no response to CLICKING the link, please download this PDF first and then click on it.

CLICK HERE TO **DOWNLOAD** THE COMPLETE MANUAL