

49HR BLAST HOLE DRILL OPERATOR'S MANUAL

Manual No.
11201
SN: 141368
2C70X20

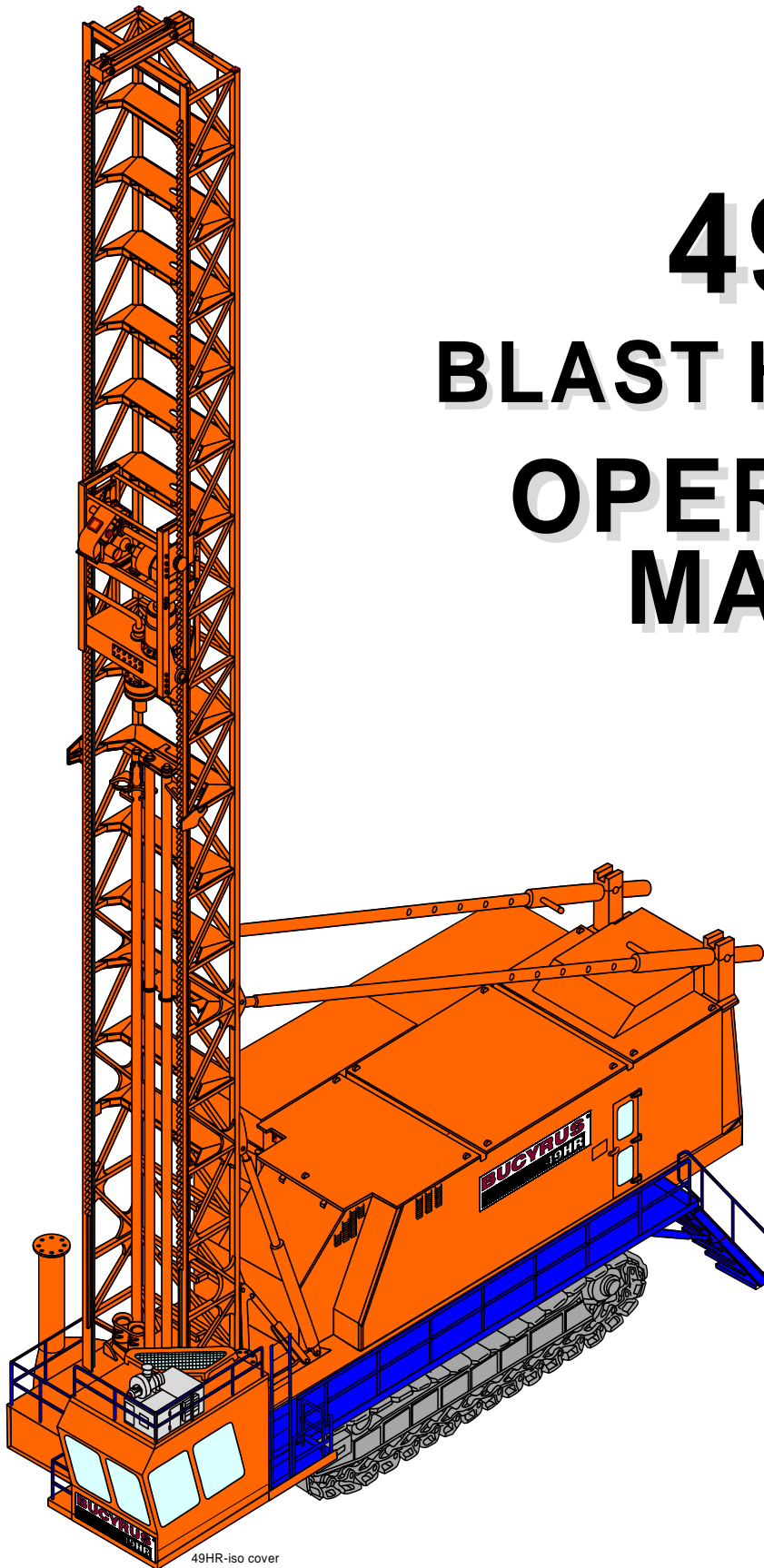

141368_mnc Pg. 2

49HR-iso cover

Bucyrus International, Inc.

1100 Milwaukee Ave. • P.O.Box 500 • South Milwaukee, Wisconsin 53172-0500 USA

CLICK HERE TO **DOWNLOAD** THE COMPLETE MANUAL

- Thank you very much for reading the preview of the manual.
- You can download the complete manual from: www.heydownloads.com by clicking the link below



- Please note: If there is no response to CLICKING the link, please download this PDF first and then click on it.

CLICK HERE TO **DOWNLOAD** THE COMPLETE MANUAL



SAFETY PRECAUTIONS

General Precautions:

- The employment of qualified maintenance personnel, through a scheduled maintenance program, is the best way to minimize machine downtime and maximize productivity of equipment.
- Keep hands, feet, and clothing away from rotating parts.
- Wear a hard hat, safety shoes and protective lenses at all times.
- Replace any and all safety and warning placards if they are defaced or removed from the machine.
- Think before you act. Carelessness is one luxury the service man cannot afford.
- Excessive or repeated skin contact with sealants or solvents may cause skin irritation. In case of skin contact refer to the Material Safety Data Sheet (MSDS) for that material and the suggested method of cleanup.
- Inspect safety catches (keepers) on all hoist hooks. Do not take a chance, the load could slip off of the hook if they are not functioning properly.
- If a heavy item begins to fall, let it fall, don't try to catch it.
- Keep your work area organized and clean. Wipe up oil or spills of any kind immediately. Keep tools and parts off of the ground. Eliminate the possibility of a fall, slipping or tripping.
- Floors, walkways and stairways must be clean and dry. After fluid draining operations be sure all spillage is cleaned up.
- Electrical cords and wet metal floors make a dangerous combination.
- Regularly inspect for any loose bolts or locking devices and properly secure them.
- Use extreme caution while working near any electrical lines or equipment whether it be high or low voltage. Never attempt electrical repairs unless you are qualified.
- Check limit switches for proper operation.
- After servicing, be sure all tools, parts or servicing equipment are removed from the machine and secured in an appropriate storage area.
- Mechanical Brakes are designed for use as static holding brakes only. Use as a motion (dynamic) brake in emergency situations only.
- Use proper interior and exterior lighting.
- Install and maintain proper grounding and ground fault protection systems.
- Perform functional tests of all safety circuits.
- Allow electrical inspection and maintenance to be performed only by a qualified electrician.
- Use extreme caution when working around drilled holes.



PROPEL MACHINERY

The propel system of this machine is a chainless hydraulic drive system which will allow the separate tracks to counter-rotate. This capability provides the machine with the capacity to turn completely around within its own length. Each track is driven by a hydraulic motor and a planetary gearbox equipped with a hydraulically released, spring activated brake. The machine is capable of 2 different propel speed ranges. The lower speed range is used for maneuvering in close spaces while the high speed range is used for tramping in open areas, over long distances.

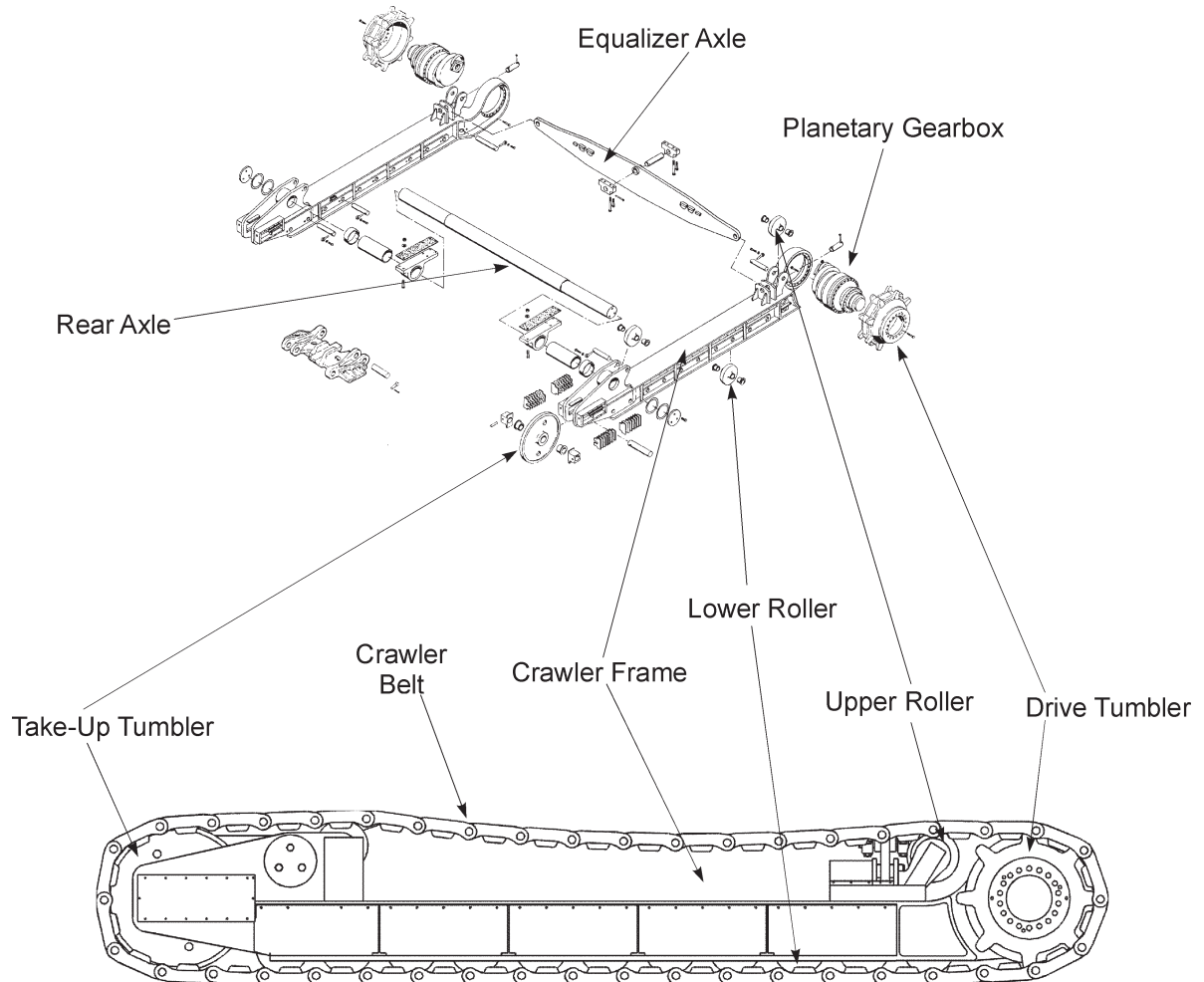

S1_0012



BREAKOUT WRENCH

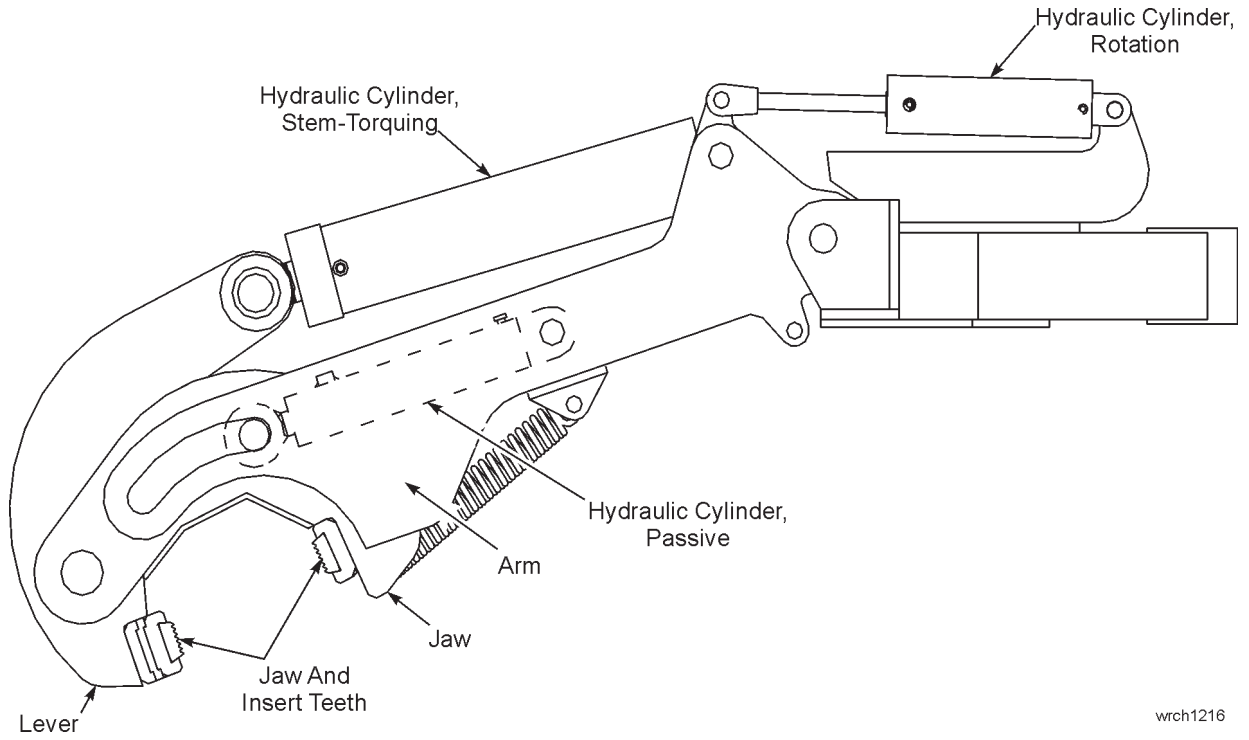

wrch1216

CABLE REEL

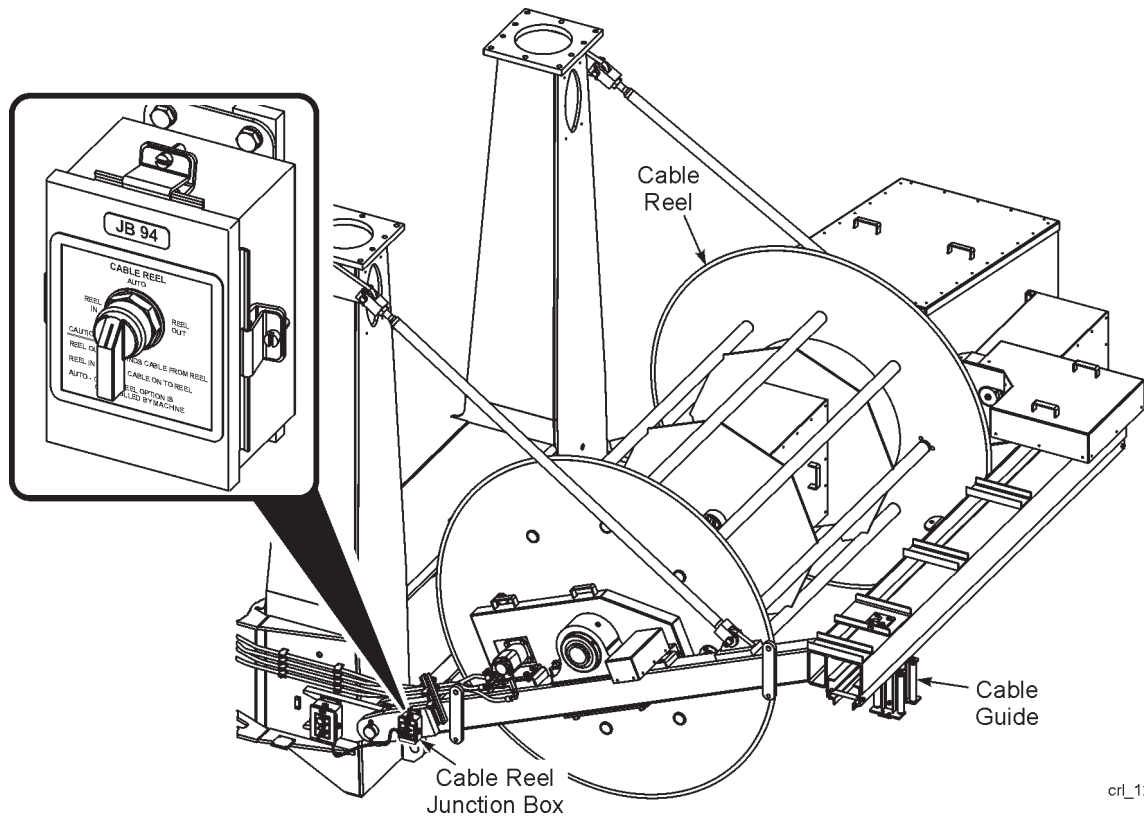

cr_1295



RIGHT CONTROL CONSOLE

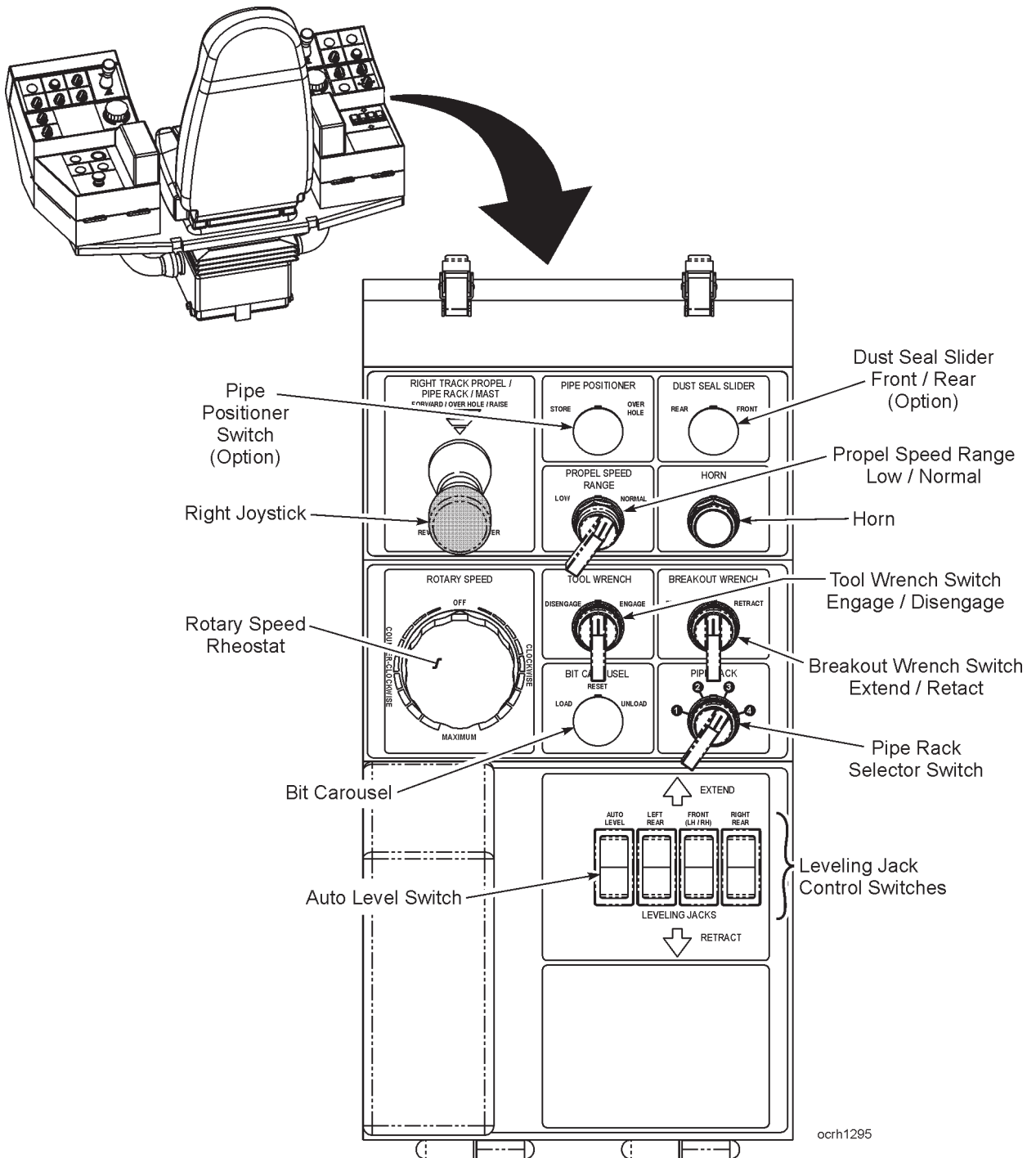

RIGHT CONTROL CONSOLE - OVERVIEW



49HR Blast Hole Drill

ACTIVE ALARMS				
...	Date	Time	Code	Message Text
1	02/11/10	12:47:00 PM	ANW016	TIP WARNING (DECK ANGLE GREATER THAN 7.5 DEG)
2	02/11/10	12:47:00 PM	ANF099	PIW294 (FRLM) INPUT OUT OF RANGE
3	02/11/10	12:47:00 PM	ANF098	PIW292 (SSLM) INPUT OUT OF RANGE
4	02/11/10	12:47:00 PM	ANF090	PIW276 (ACATT) INPUT OUT OF RANGE
5	02/11/10	12:47:00 PM	ANF089	PIW274 (ACOTT) INPUT OUT OF RANGE
6	02/11/10	12:47:00 PM	ANF088	PIW272 (ACPT) INPUT OUT OF RANGE
7	02/11/10	12:46:59 PM	ANW024	UPS BATTERY LOW
8	02/11/10	12:46:59 PM	ANW023	UPS ALARM
9	02/11/10	12:46:59 PM	ANW022	HMI RUNNING ON UPS
10	02/11/10	12:46:59 PM	ANW009	PROPEL BRAKES RELEASED FOR TOWING
11	02/11/10	12:46:59 PM	ANW008	HYDRAULIC TANK VALVE CLOSED
12	02/11/10	12:46:59 PM	ANF048	HEAD OVERSPEED FAULT
13	02/11/10	12:46:56 PM	ANF065	MASTER SWITCHES NOT IN NEUTRAL
14	02/11/10	12:46:56 PM	ANF058	24VDC UTILITY POWER FAULT
15	02/11/10	12:46:56 PM	ANF053	24VDC INPUT POWER FAULT
16	02/11/10	12:46:56 PM	ANF052	24VDC CONTROL POWER FAULT
17	02/11/10	12:46:56 PM	ANF010	PHASE SEQUENCE LINE FAULT
18	02/11/10	12:46:56 PM	ANF000	EMERGENCY STOP ACTIVE

aas_1295

ACTIVE ALARM

The Active Alarm screen will provide a list of all active alarms and faults that have been initiated on the machine and have not been RESET. Once an alarm or fault has been sensed, these messages will remain visible and WILL NOT be removed from this screen until it is RESET.

ANW016 TIP WARNING (DECK ANGLE GREATER THAN 7.5 DEG)

LIMITS	ROTARY CURRENT 0.0 Amps	HOIST/DPD CURRENT 0.0 Amps	HOIST Enable	ROTARY Enable
	ROTARY SPEED 0.0 rpm	HOIST/DPD SPEED 0.0 rpm	Joint	
	BAILING AIR PRESSURE 0.0 psi	TOTAL PD FORCE 0.0 kLbs	STATUS	
CONTROL ENABLE OFF	LEVEL Coarse		Masterswitch Neutral	
OPERATING MODE MAIN MOTOR OFF	DRILLING DATA		Jacks Retracted	
TORQUE CONTROL ENABLE	Hole Depth: 0.0 ft		Lube System Fault	
BRAKE RELEASED	Bit Position: 0.0 ft		Bearding Stairs Down	
	Head Position: 0.0 ft		PDC Limit	
	Water Flow: 0.0 gpm		Hole Clogged	
			Low Water	
			Remote Transmitter On	
			Remote Propel Active	

sswp1295

STATUS SCREEN with Pop-up Ribbon

Any new alarms will pop-up automatically any time that a machine sensor detects a newly occurring fault or warning message.

CLICK HERE TO **DOWNLOAD** THE COMPLETE MANUAL

- Thank you very much for reading the preview of the manual.
- You can download the complete manual from: www.heydownloads.com by clicking the link below



- Please note: If there is no response to CLICKING the link, please download this PDF first and then click on it.

CLICK HERE TO **DOWNLOAD** THE COMPLETE MANUAL



14. Check the safety restraint cables on the mast. Be certain that the cables and supports are in good repair with no cracks, missing or loose hardware or any damage that could affect their effectiveness.
15. Every 160 hours inspect the upper auxiliary winch sheaves. All pins, keepers and hardware should be secured.
16. Check the machinery house air filtering fan duct to see that it is clear of obstructions.
17. Inspect dust collector hoses for integrity.

ONBOARD INSPECTION

1. Inspect the air compressor lubrication lines for leaks. Correct any leaks found immediately.
2. Check the condition of the air compressor intake filter. Replace the filter cartridge if the red flag is visible in the service indicator. Empty the dust hopper and clean the pre-cleaner element. Inspect the housing and ductwork for damage or leaks. Repair or replace leaking components.
3. Check the oil level in the hydraulic tank. Fill the tank to the proper level as described on the instruction plate on the tank.
4. Check hydraulic system for leaks. Correct all leaks immediately and clean up all oil spills immediately.
5. If the machine is equipped with a bit lubricator for the main air system, check that the lubricator is full.

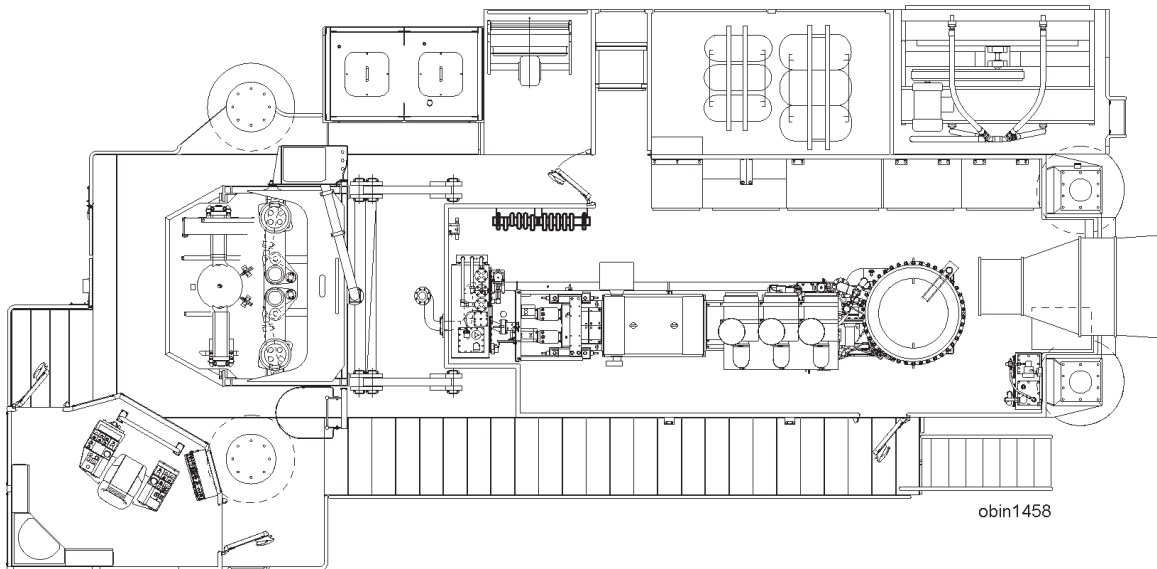

6. Inspect the automatic lubrication central pumping stations for proper operation. Check the supply of lubricant; refill tank as necessary.



6. Rotate the pulldown force rheostat in the pulldown direction to lower the rotary/pulldown unit. The farther the rheostat is turned to the left the faster the unit will be lowered.
7. When the hoist/pulldown operations are complete, set the hoist/pulldown speed rheostat to the OFF position and then turn the hoist brake switch to the SET position.



CAUTION: Whenever the hoist/pulldown speed rheostat is in the OFF position, the hoist brake switch must be in the SET position to prevent the rotary/pulldown unit from creeping downward due to the weight of the unit.

AUXILIARY WINCH OPERATION

To operate the auxiliary winch proceed as follows:

1. Place the operation mode selector switch in the MAST/WINCH position.
2. To hoist the auxiliary winch line, lift and move the winch joystick, located on the right console, forward. To stop the line, return the joystick to the NEUTRAL position.
3. To lower the winch line, lift and move the joystick rearward. To stop the line, return the joystick to the NEUTRAL position.

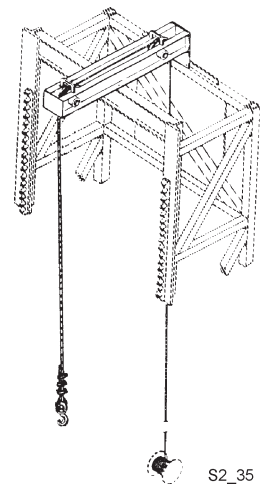



13. When the stabilizer begins to turn with the drill pipe, check the joint between the stabilizer and the pipe. The shoulders on the pipe and stabilizer must be together. If there is clearance between the shoulders, it will be necessary to tighten the joint some more before the stabilizer is released. If the shoulders of the pipe and stabilizer are contacting, the joint is made up.

Installation of the drill bit is the last step in preparing the tool string.

To install the bit, proceed as follows:

1. Hoist the completed drill pipe/stabilizer assembly 2 to 3 ft (0.6 to 0.9 m) off the drill deck. Place the bit basket (furnished with machine) into the hole left by the guide bushing in the drill deck. Remove all personnel from the drilling deck and the immediate area. Turn on the main air stream to blow any contaminants from the drill pipe and stabilizer.
2. Place the bit into the bit basket. Coat the threads and shoulders of the bit and stabilizer with drill pipe thread compound.
3. Turn the rotary rheostat clockwise until the tool string begins to turn at approximately 5 RPM as shown on operator's display terminal operator's display screen. Release the hoist brake and slowly lower the rotary/pulldown unit and tool string onto the bit. Lower the drive unit in small increments until the threads catch and the stabilizer starts to thread itself onto the bit. As soon as the threads start to catch, set the hoist brake and let the stabilizer screw itself onto the bit.
4. When the joint is tight the rotary unit will slow down and the rotary load meter will show an increased load. At this point return the rotary rheostat to the neutral position.
5. After making the bit to stabilizer joint, hoist the rotary drive unit to allow the bit basket to be removed. Remove the bit basket and store it in a safe place.
6. Lower the completed tool string so that the guide bushing is seated in the hole in the drill deck. Set the hoist brake and press the control ENABLE button. The tool string is now complete for single pass drilling or for the first pass of multiple pass drilling.

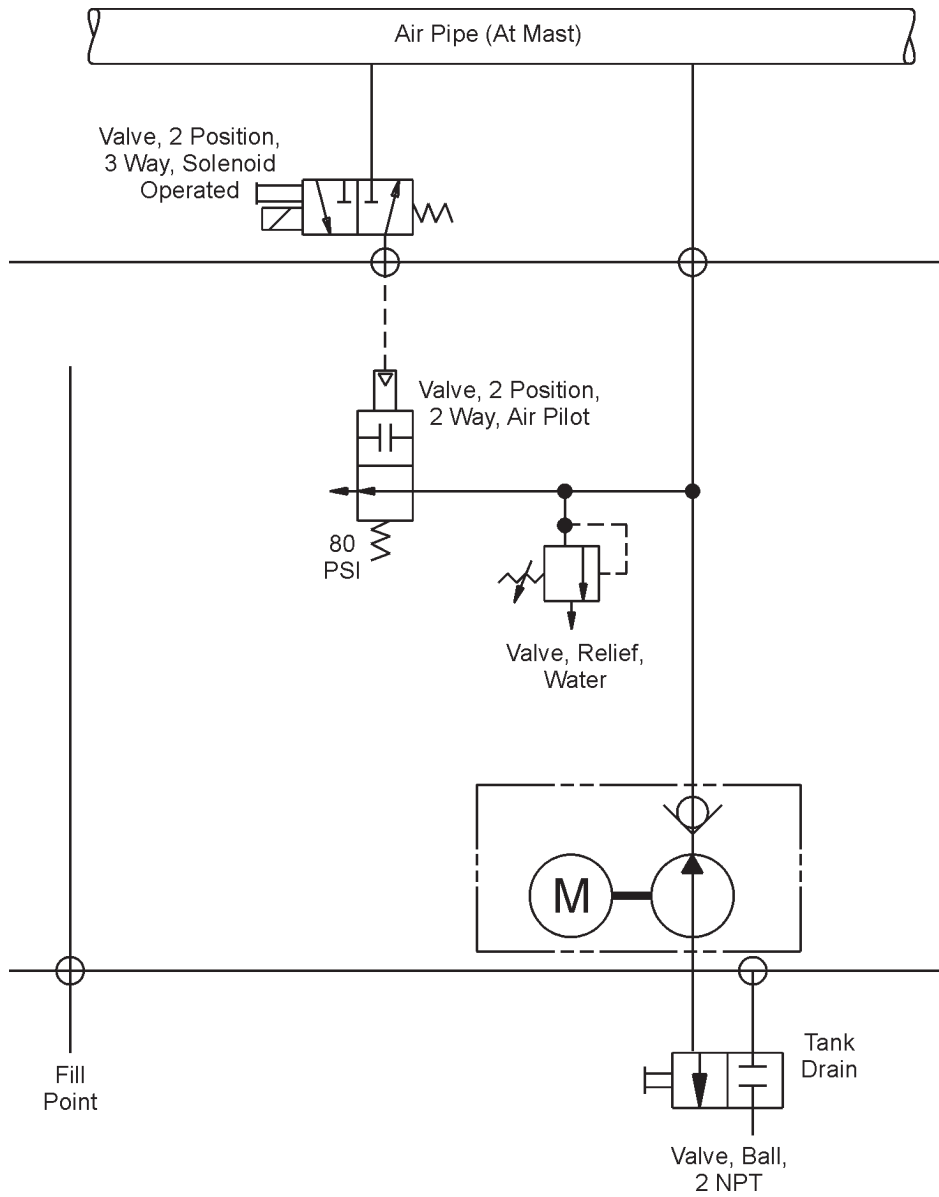

WMS 1175

WATER INJECTION SYSTEM



In the case where the material is conglomerating into large pieces, these pieces fall back down to the bottom of the hole and are recycled through the bit to be broken up. If the amount of recycled material is too great it will accumulate at the bottom of the hole and restrict the main air stream. To keep this material at a minimum, clean the hole periodically. When hoisting the tool string, allow the material to be ground by the bit and fall to the bottom of the hole before cleaning the hole.

In the case where the material is caving from the sides of the hole, treat the formation as unconsolidated and drill according to the procedure detailed in this manual for unconsolidated material.

It is important when drilling through difficult formations to constantly monitor the machine and tool string. Allowing the tool string to become stuck is an expensive mistake and can be avoided by cautious drilling practices. Reaming and cleaning the hole may only take a few moments, but it could be the difference between an abandoned hole and tool string and a successfully completed hole.

ANGLE DRILLING

NOTE: When moving the mast for angle hole drilling on machines with mast lengths of 65 ft. or more, the drill pipe must be stored in the racks and the rotary head lowered to its lowest position.

Angle drilling follows the same general drilling procedures as vertical drilling. The main difference in the drilling procedures, besides the fact that the hole is at an angle, is the need to monitor the condition of the different systems more closely while angle drilling. The differences in the operating procedures for the different systems on the machine are limited to handling the tool string and raising and lowering the mast to the proper drilling angle.

When drilling an angle hole, monitoring of the system indicators such as the drilling air pressure, the rotary load and the machine vibration, becomes more critical than when drilling a vertical hole. The reason these monitors become more important is the fact that an angle hole will tend to wander downward as the hole is being drilled. This wandering is due to the drill steel assuming a natural camber as it is being extended past the guide bushing. This camber is unavoidable and becomes worse as the angle of the hole approaches 25 degrees.

The force of gravity continually acts upon the tool string causing it to bend downward. This downward bending is known as the camber of the drill pipe. This camber causes the hole to be drilled with a gradual bend in it. This causes the drill pipe to contact the side of the hole, increasing the load on the rotary motor. This also tends to inhibit the bailing of the hole since the cuttings are not flowing vertically. The flow of the bailing air (and suspended cuttings) must be diverted around the points that the drill pipe is resting on the side of the hole. This contributes to the increased air pressures needed to drill an angle hole. The vibration of the tool string will be increased while drilling at an angle, due to the tool string resting on the side of the hole, rather than on the bottom.

CLICK HERE TO **DOWNLOAD** THE COMPLETE MANUAL

- Thank you very much for reading the preview of the manual.
- You can download the complete manual from: www.heydownloads.com by clicking the link below



- Please note: If there is no response to CLICKING the link, please download this PDF first and then click on it.

CLICK HERE TO **DOWNLOAD** THE COMPLETE MANUAL