

Magnum 255 Series Tractors After P.I.N. Number Z8RZ06001

Operator's Manual

84163221
Issued August, 2008
1st Printing

CASE IH
AGRICULTURE

CLICK HERE TO **DOWNLOAD** THE COMPLETE MANUAL

- Thank you very much for reading the preview of the manual.
- You can download the complete manual from: www.heydownloads.com by clicking the link below



- Please note: If there is no response to CLICKING the link, please download this PDF first and then click on it.

CLICK HERE TO **DOWNLOAD** THE COMPLETE MANUAL

Product identification

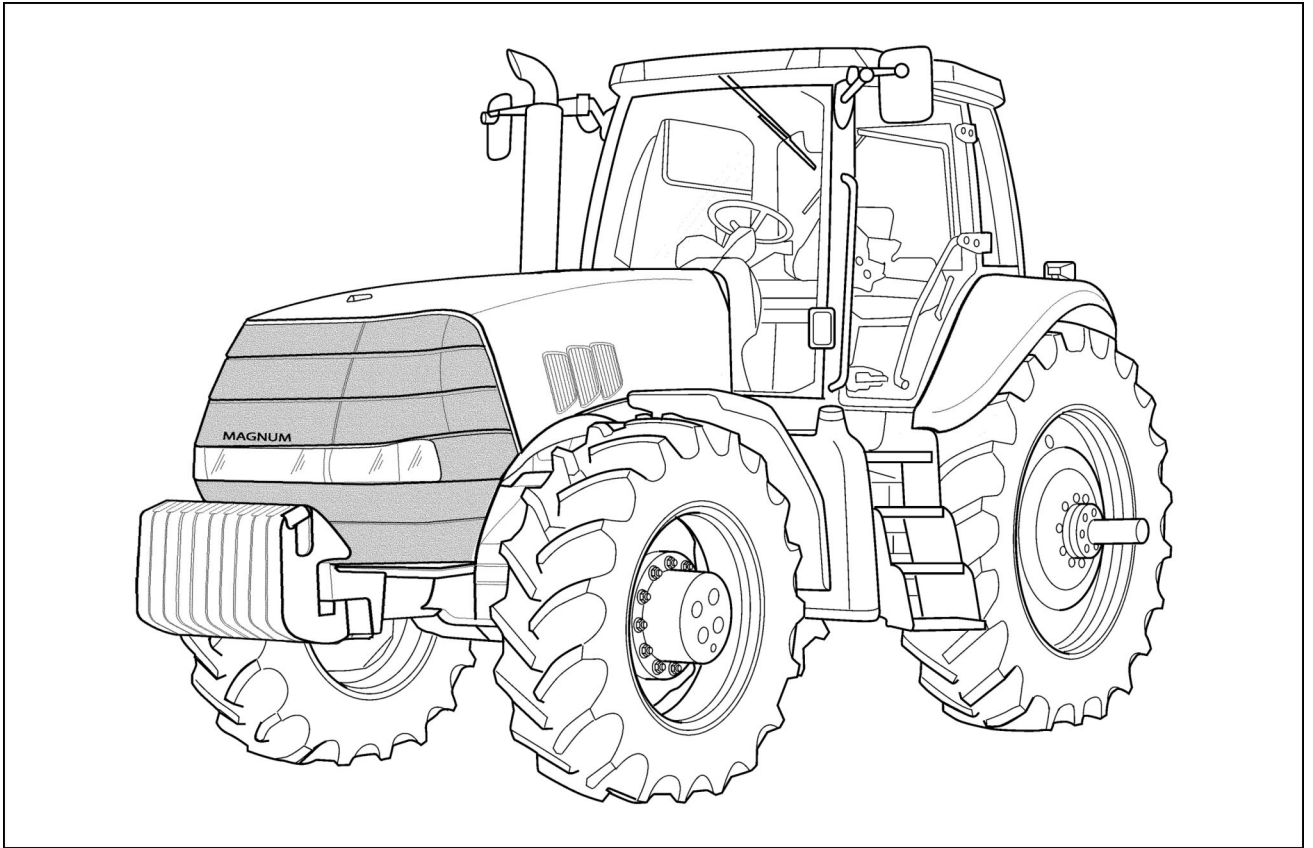

RCPH07CCH014FAB 1

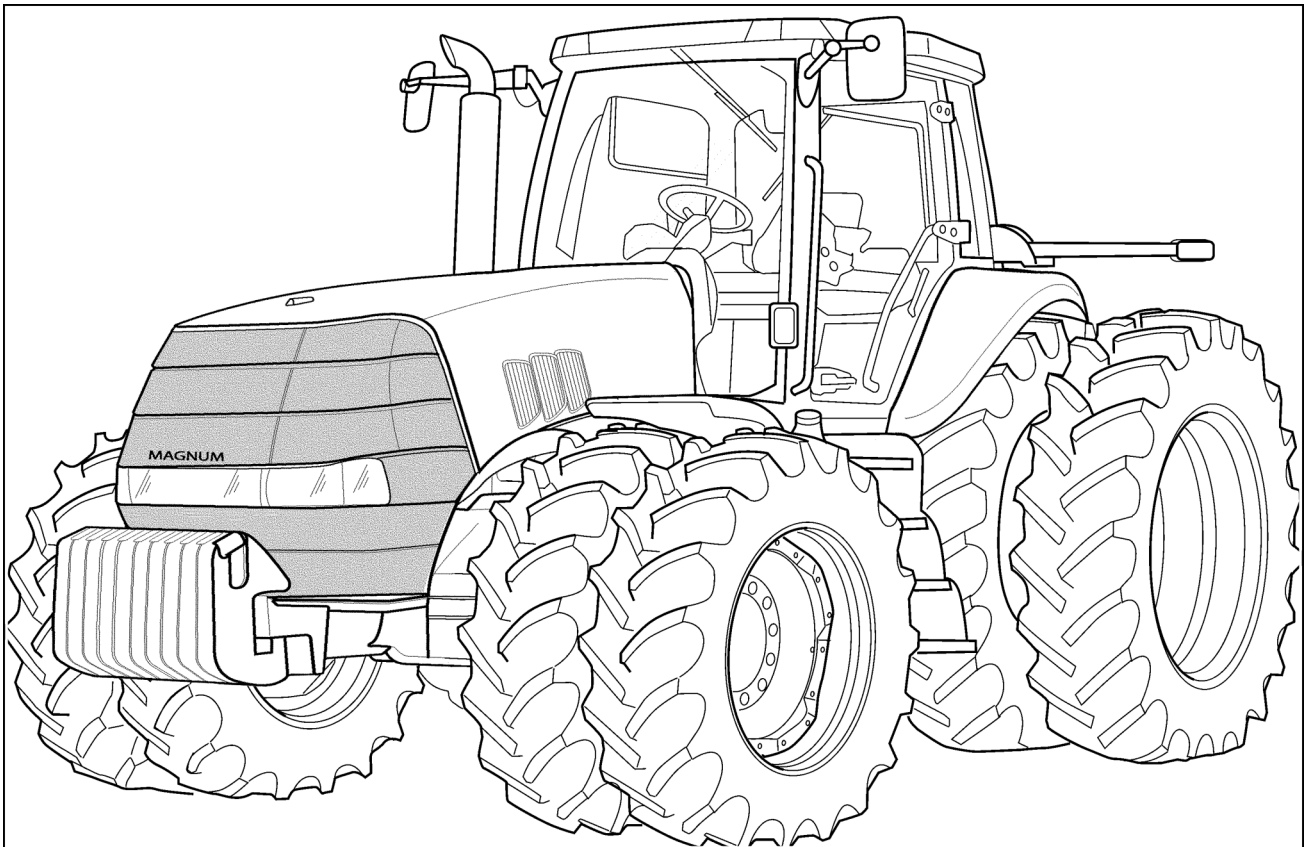

RCPH08CCH004FAB 2

INSTRUCTIONAL SEAT SAFETY

- Extra riders, especially children, are not permitted to ride on the machine.
- The Instructional Seat is used only when training a new operator or when a service technician is diagnosing a mechanical problem.
- A frequent cause of personal injury or death is persons falling off and being run over. DO NOT permit others to ride, except in designated instructional seat.
- When the Instructional Seat is occupied, the following precautions must be taken:
 - A. Machine should be driven at a slower speed and on level ground.
 - B. Avoid driving on highways or public roads.
 - C. Avoid quick starts or stops.
 - D. Avoid sharp turns.
 - E. Always wear seat belts.
 - F. Cab door must be closed at all times.

**WARNING**

Before starting the engine make sure seat belts are securely fastened. The seat belt can help insure your safety if it is used and properly maintained. Never wear a seat belt loosely or with slack in the belt system. Never wear the belt in a twisted condition or pinched between the seat structural members.

M422B

**WARNING**

A frequent cause of death or serious injury is persons falling off machinery and being run over. Keep cab door closed. Instructional seat is used only for instructing or service diagnosing only. DO NOT permit others to ride, especially children. Seat belt must be worn at all times.

M488C

FIRE SAFETY

- Fire risks can be minimized by frequent removal of accumulated crop material, trash or debris from the machine.
- Remove all crop material, trash or debris from the machine each day. Especially check the engine area and exhaust system.
- Engine fuel can cause an explosion or fire. DO NOT fill the fuel tank with the engine running; if you are near an open fire; or if you are welding, smoking, etc.
- Refer to Fire Prevention in the Maintenance Section of this manual for additional information.

**CAUTION**

It is good practice to carry a fire extinguisher on the machine. Be sure that the extinguisher is properly maintained and be familiar with its proper use.

M102B

MAINTENANCE SAFETY

- Always keep safety and informational decals clean and visible. Replace decals that are damaged, lost, painted over or can not be read.
- When assembling, operating or servicing the machine, wear protective clothing and personal safety devices that are necessary for the particular procedure. Some personal safety devices that may be necessary are protective shoes, face and/or eye protection, hard hat, heavy gloves, filter mask and hearing protection.
- DO NOT wear jewelry or loose fitting clothing that may get caught in moving parts. Always wear close fitting clothing. Keep hands, feet, clothing and hair away from moving parts.
- Never attempt to clear obstructions or objects from the machine while the engine is running.
- Always stop the engine and remove the key from the key switch when leaving the operator's seat or the machine.
- When servicing the machine, always have the machine on a firm level surface.
- If shields or guards are removed or opened for service, always replace them before operating the machine.

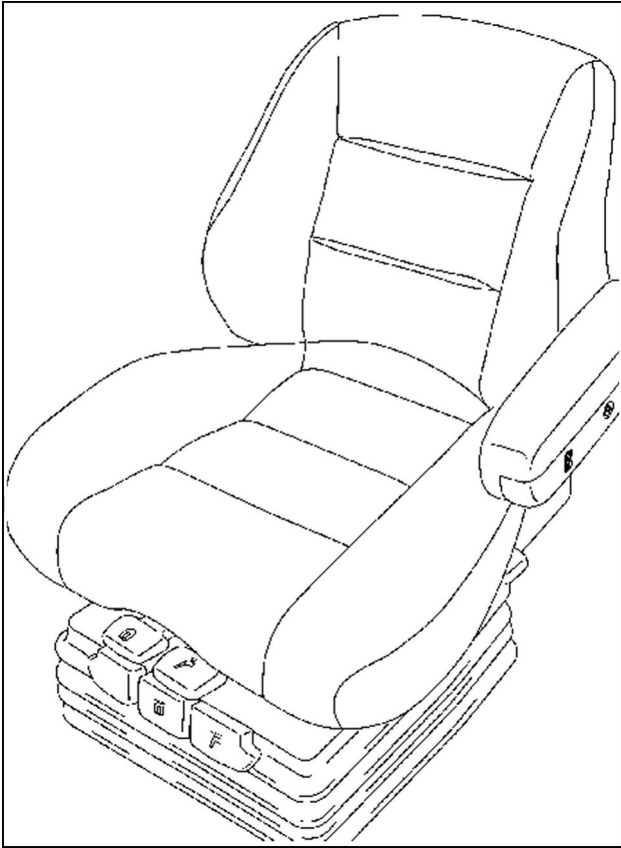

RCPH08CCH868BAC 3

Luxury seat

PEDAL CONTROLS

Inching pedal

When the inching pedal is pushed down, the transmission is disconnected. Use the inching pedal when moving the tractor in a small area or when connecting implements.

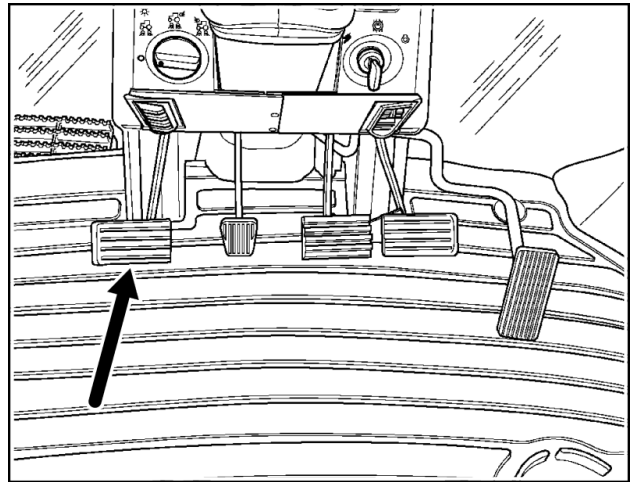

RCPH08CCH085AAC 1

Steering column tilt/telescopic pedal

The steering column tilts to 13 different positions. To tilt or telescope the steering wheel, push the tilt/telescopic pedal down and move the steering column to the desired position. Release the tilt/telescopic pedal to keep the column in the selected position. Move the column to the most forward position for ease of entry and exiting.

NOTE: To tilt the column, partially depress the pedal. To telescope the column, fully depress the pedal.

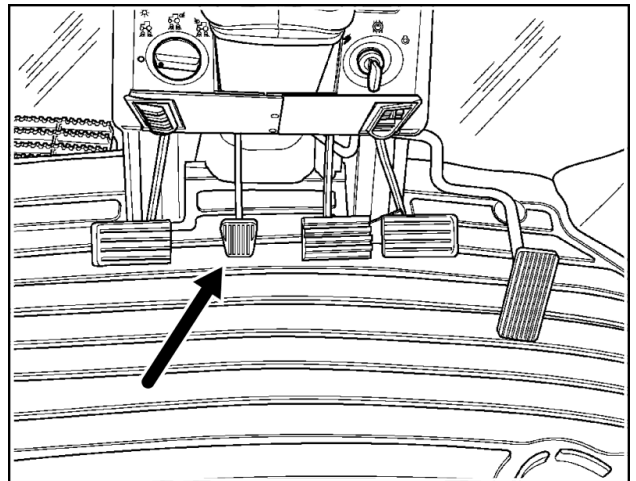

RCPH08CCH085AAC 2

Remote auto mode switch (if equipped)

1
0
3

This switch engages/disengages auto mode for remote valves 1 and/or 3. Auto mode is used with implements which control the remote valves by themselves. The forward position engages/disengages the first remote valve, the rear position the third remote valve. Both valves can be simultaneously or independently engaged or disengaged.

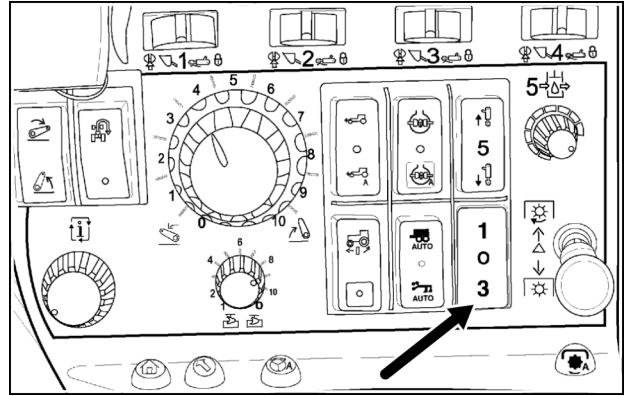

RCPH08CCH857AAC 19

PTO control switch

The PTO switch knob is colored yellow for easy identification.

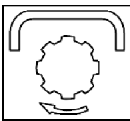

To engage the power take off, lift the knob while moving it forward. The knob remains in a raised position. The PTO icon on the tractor instrumentation displays when the PTO is engaged, and PTO RPM is shown.

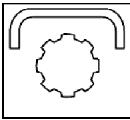

To disengage the power take off, move the control knob rearward.

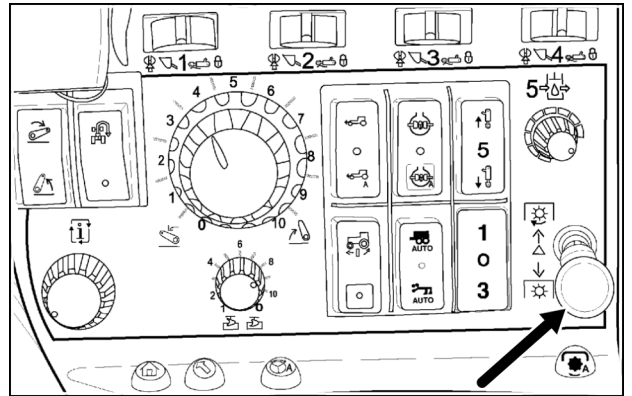

RCPH08CCH857AAC 20

FENDER CONSOLE

Front wiper/washer control



Turn the control clockwise to Low (I) or High (II) and counterclockwise to turn the wiper Off. Push the control to activate the windshield washer (if equipped).

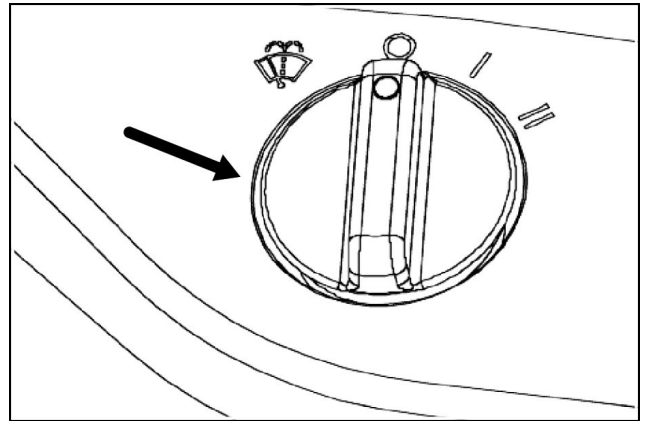

RCPH08CCH850AAC 1

Front wiper/washer control with variable delay



Turn the control clockwise to the Variable delay range, or the Low (I) or High (II) position. Turn the control counterclockwise to turn the wiper Off. Push the control to activate the windshield washer (if equipped).

The control decal indicates the range for wiper variable delay. Turn the control clockwise within the range to vary the delay.

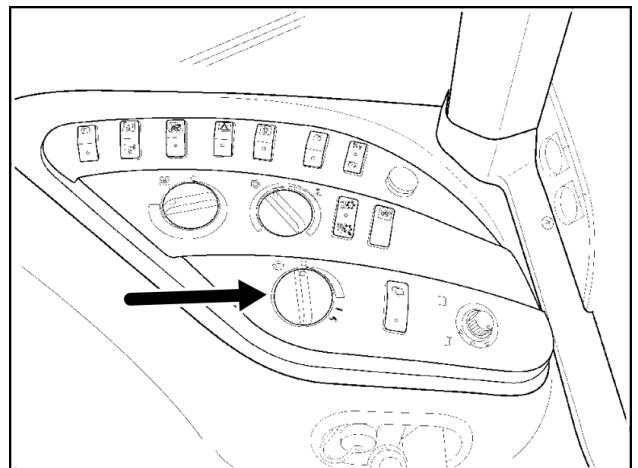

RCPH08CCH107AAC 2

Rear and side wiper switch (if equipped)

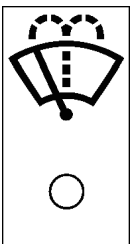

Press the switch top to turn the rear and side wiper On; press and hold the switch top to activate the rear and side window washer. The bottom switch position is Off.

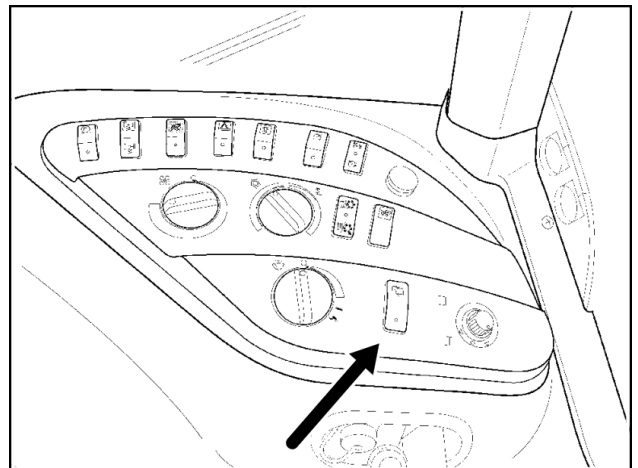

RCPH08CCH107AAC 3

OVERHEAD CONTROLS

LAMPS

Dome lamp

The switch position for the dome lamp determines lamp operation:

- Left position – Dome lamp illuminates continuously until the switch is turned Off. Move the switch to the center position to turn the lamp Off.
- Center position – Dome lamp Off.
- Right position – Dome lamp illuminates when the cab door is opened and turns Off when the cab door is closed.

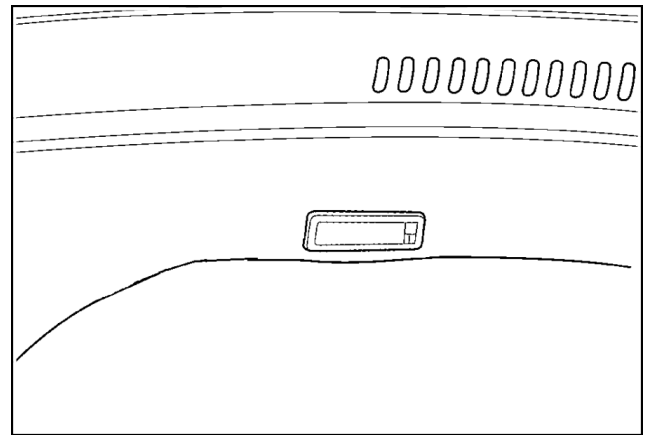

RCPH08CCH031AAC 1

Map lamp (if equipped)

The map lamp is located in the upper right head liner. Toggle the lamp On and Off by pressing the switch. Direct the light beam by grasping the lens and rotating it to the desired position.

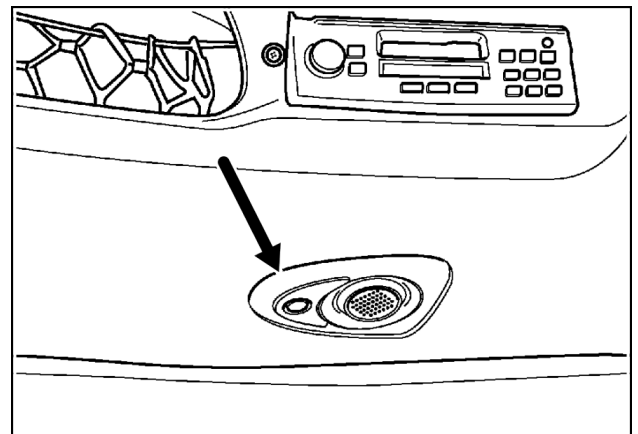

RCPH08CCH096AAC 2

STATUS AND WARNING ICONS

A panel for status and warning icons is part of the tractor instrumentation. The icons illuminate to tell the operator that tractor operation should stop or that a function is operating. On tractor startup, all icon lamps illuminate briefly during a self-test.

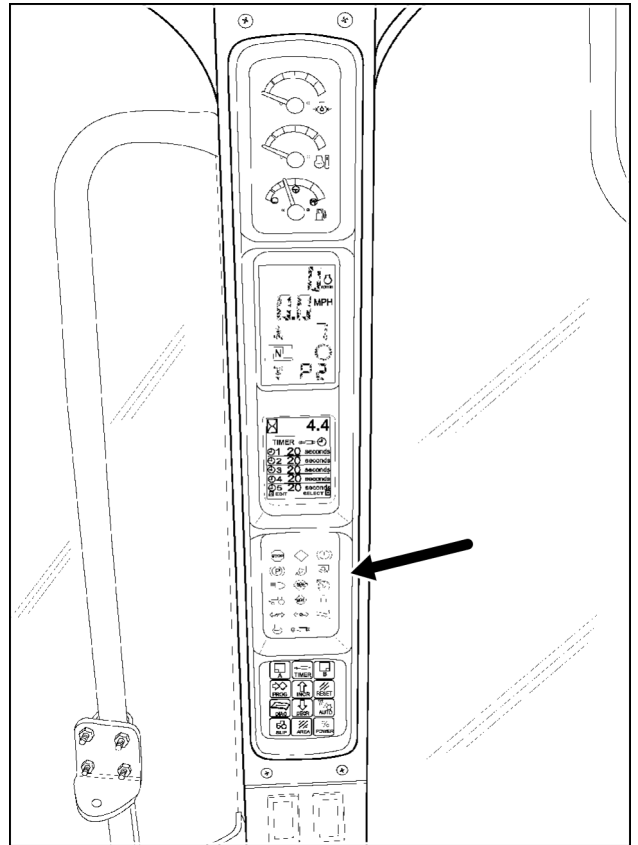

RCPH08CCH189BAC 1

Fuel usage

This screen displays fuel remaining and the fuel usage rate at this instant.

Press the INCR or DECR key until the fuel remaining screen is displayed. This screen shows the amount of remaining fuel in liters (gallons), and the rate of consumption per hour on electronically controlled engines only.

The fuel information function is active at all times. The fuel remaining is based on current fuel tank levels. The fuel consumption per hour is based on electronic governor data and is only displayed when that data is available.

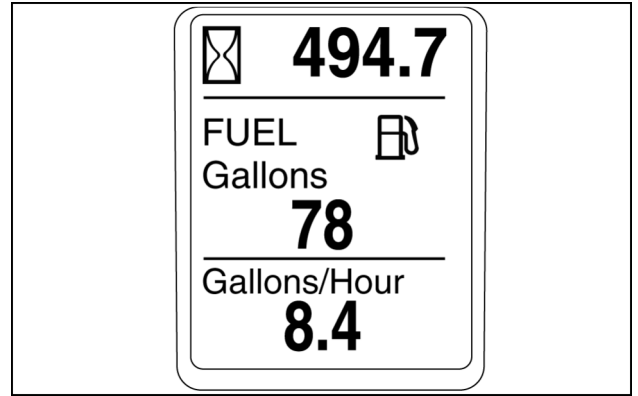

RCIL08CCH116AAA 11

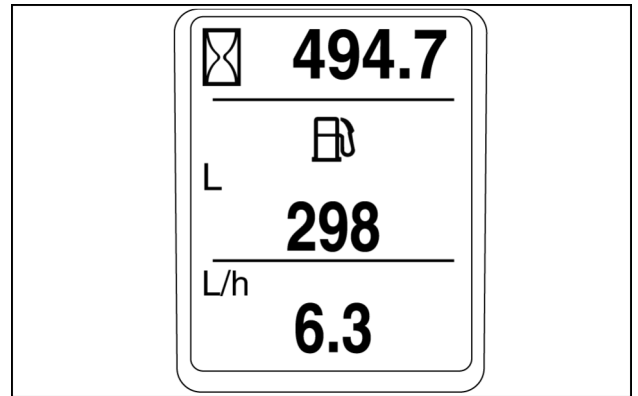

RCIL08CCH117AAA 12

To edit a timer value:

- Press the "A" key to highlight Timer 1 retract.
- Use the INCR or DECR key to increase to decrease the timer value for retract.

NOTE: Pressing the INCR or DECR key changes the value by 1 second each time the key is pressed. Pressing and holding the INCR or DECR key scrolls through the numbers at a faster rate

NOTE: When a value reaches 30 seconds and the INCR key is pressed, the value changes to "C" for continuous operation.

NOTE: When the function switch for a remote valve is in the hydraulic motor position, the timer value for that valve is "C" for continuous operation and cannot be edited.

- Press the "B" key (when Timer 1 retract is highlighted) to highlight the next value – Timer 1 extend.
- Use the INCR or DECR key to increase to decrease the timer value for extend.
- Press the "B" key to move through the retract and extend values for all remote valves. Use the INCR or DECR key to increase to decrease the timer value for retract/extend as required.

Press the "A" key to exit timer value editing at any time and save the edited values

NOTE: If the "A," "B," INCR, or DECR keys are not pressed for 1 minute, the edit mode exits and all values return to normal display

Timer

This screen displays elapsed time anytime the key switch is On.

Press the INCR or DECR key until the timer screen is displayed. In hours and minutes, the screen shows elapsed time from when the timer is started. Maximum elapsed time is 999 hours and 59 minutes before the timer automatically resets to zero.

While the timer screen displays, press the "B" key to toggle the timer On and Off. Current status is highlighted at the bottom of the screen.

To reset the timer to 0 (zero), while the timer screen displays, press the "A" key to highlight the current time value. Press and hold the "A" key for two seconds to reset the value to 0 (zero).

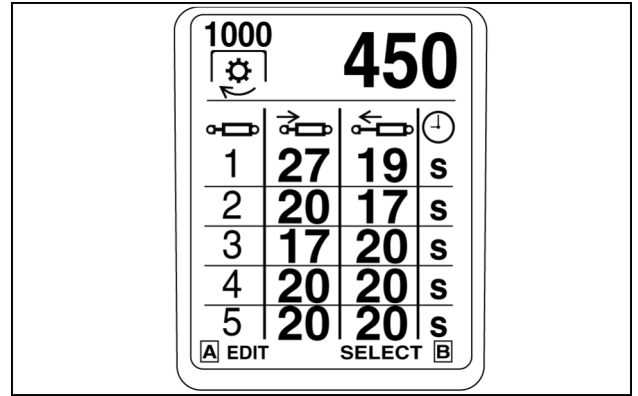

RCPH08CCH012AAA 36

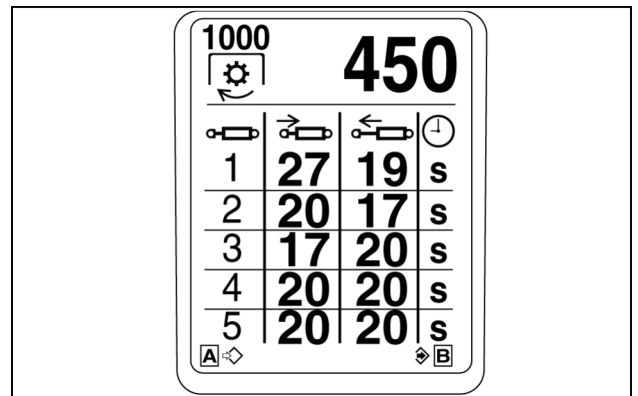

RCPH08CCH013AAA 37

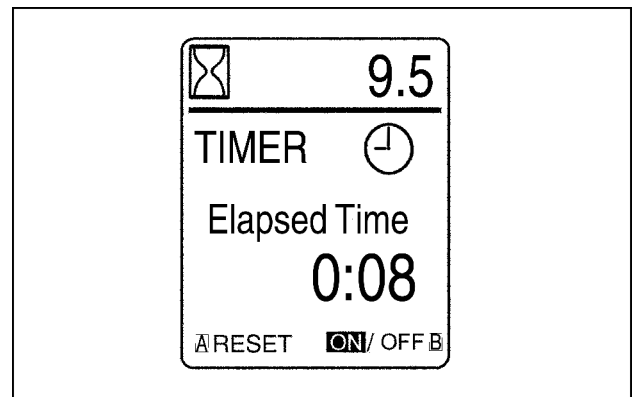

RCPH08CCH163AAC 38

For manual calibration:

5. Press the PROG key to display the default calibration number – 27.47.
6. Use the INCR or DECR key to increase or decrease the default value. Increase the value in small increment to decrease the speed reported on the instrumentation. Decrease the value in small increments to increase the ground speed reported on the instrumentation.

NOTE: Pressing the INCR or DECR key increments the value in 100ths.

7. Press the PROG key to save the new value and return to CONFIG screen.
8. Start the tractor and test the displayed speed against the GPS speed, and repeat the procedure if necessary.

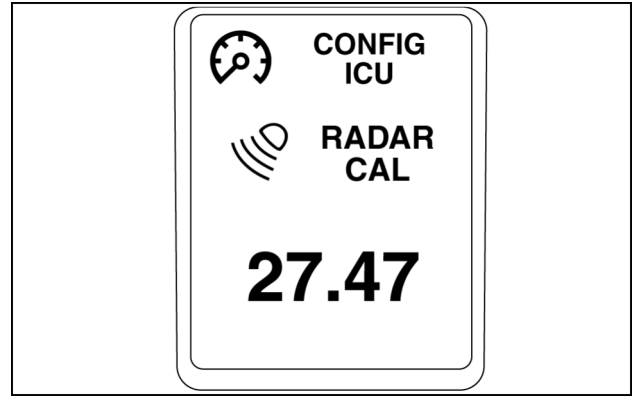

RCIL08CCH048AAA 25

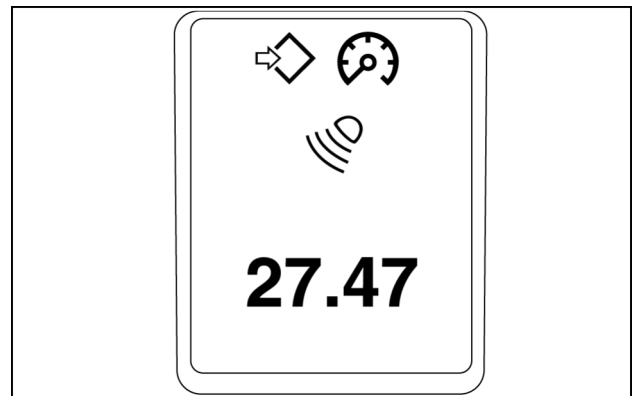

RCIL08CCH049AAA 26

For automatic calibration:

9. Lay out a level, straight-line course of **60 m (197 ft)** with a clearly marked start and finish line.
10. Park the tractor an adequate distance from the start line to achieve the speed necessary and allow time to press the correct keys.
11. Press the PROG key to display "READY."

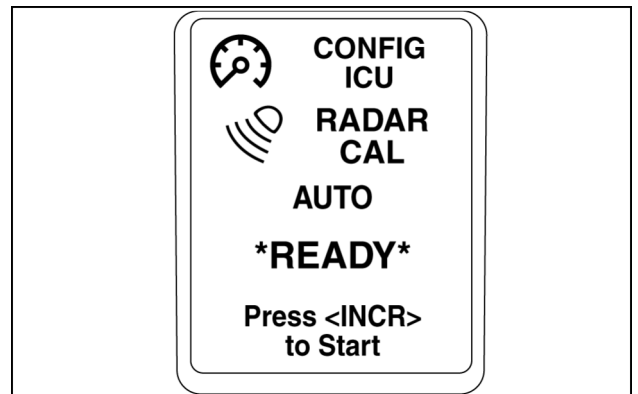

RCIL08CCH050AAA 27



RCIL08CCH051AAA 28

- The time of day automatically screen displays. Highlight "Night" and then press the PROG key to enable the egress lighting feature for night operation only.

NOTE: Night is detected as whenever the light switch is turned On before the key switch is turned Off in the current work session.

- Highlight "Always" and then press the PROG key enable the egress lighting feature whenever the vehicle is operating.

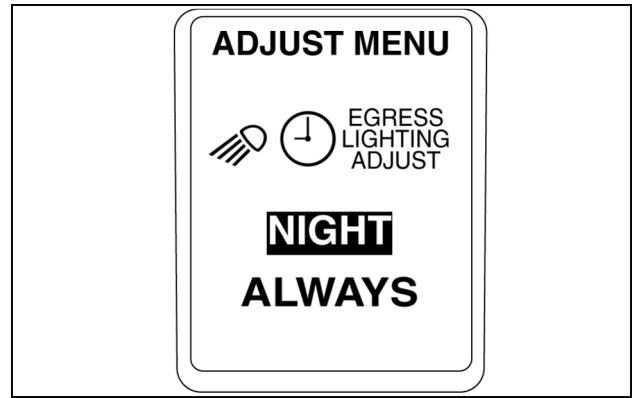

RCIL08CCH095AAA 27

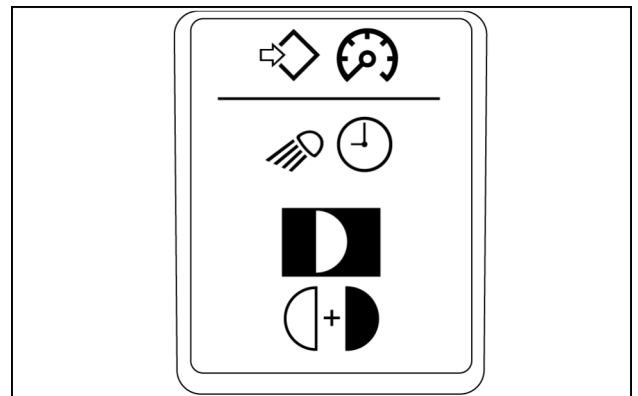

RCIL08CCH096AAA 28

- Use the INCR or DECR key to highlight "Timer," and then press the PROG key to select how long the work lamps should remain illuminated after the key switch is turned Off.

- The time of day also automatically displays when "Timer" is selected; press the PROG key to accept the default setting and advance to the Timer screen.

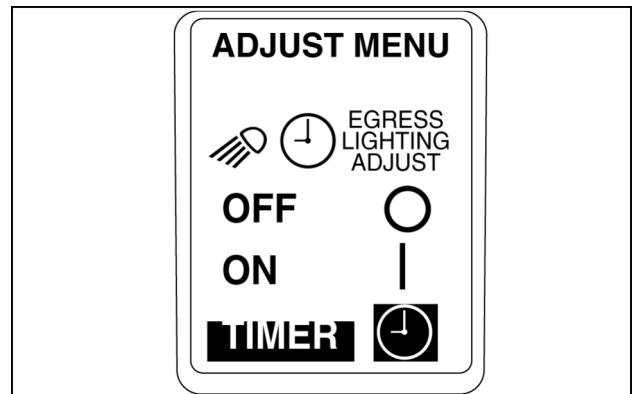

RCIL08CCH091AAA 29

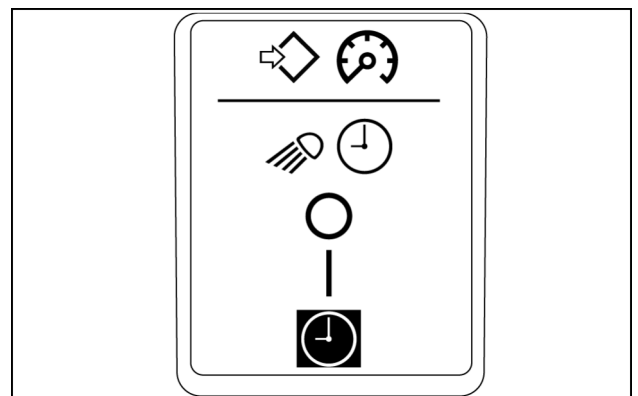

RCIL08CCH094AAA 30

Service indicator lamps and displays

When the key switch is turned to the On position, the tractor instrumentation does a self-check of monitored systems. All indicator lamps and display screens energize for three (3) seconds. Before starting the tractor, make sure all systems are operating. If any system is not operating, see your dealer.

IMPORTANT: Monitor the gauges while operating the tractor to check the performance of all tractor functions.

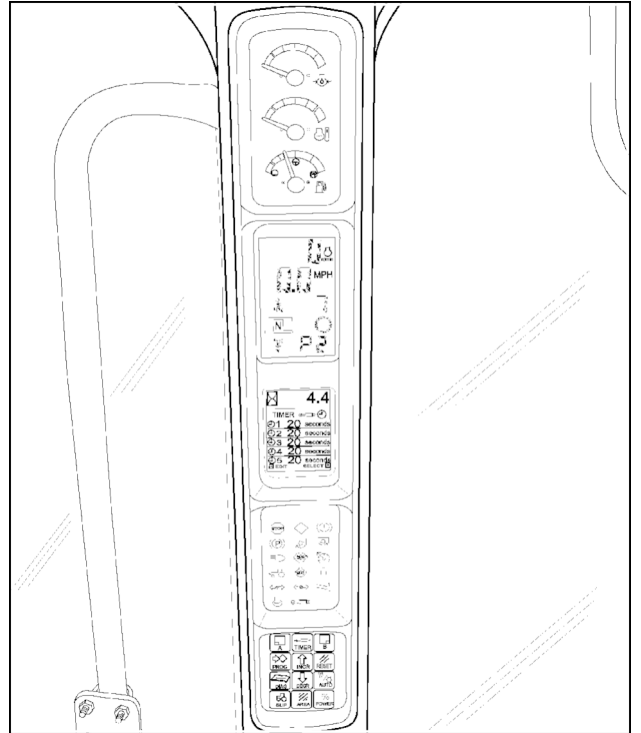

RCPH08CCH189BAC 3

MOVING THE UNIT

Powershift transmission

Your tractor is equipped with a full power shift transmission. The full power shift design permits shifting the transmission without using the inching pedal, except the first time the transmission is engaged on startup and when the operator leaves the seat for more than 2 seconds. This includes changing gears when the tractor is moving, stationary or changing the direction of travel.

Your tractor may be equipped with one of the following options.

Transmission speed options	
Option 1 – Forward	18 speeds
Option 1 – Reverse	4 Speeds
Option 2 – Forward	19 Speeds
Option 2 – Reverse	4 Speeds
Option 3 – Forward	23 Speeds (Includes Creeper)
Option 3 – Reverse	6 Speeds

IMPORTANT: As a safety feature on tractor startup, the inching pedal must be depressed before moving the transmission from Park to either Forward or Reverse. If the inching pedal is not depressed, an alarm sounds; the message “CP” (for clutch pedal) displays on the instrument cluster, and the transmission does not engage. Once the tractor is started and the transmission is first engaged with the inching pedal, shifting without using the inching pedal is available anytime as long as the operator does not leave the seat.

Transmission controller software prevents the power shift transmission from shifting up beyond a certain gear depending on transmission oil temperature. This is done to eliminate the possibility of excessive clutch wear by shifting into higher gears at lower temperatures. The limits are as follows:

Oil temperature less than or equal to	Limits power shift to
-40 °C (-40 °F)	10th Gear
-10 °C (14 °F)	11th Gear
-5 °C (23 °F)	12th Gear
0 °C (32 °F)	13th Gear
2 °C (35.6 °F)	14th Gear
4 °C (39.2 °F)	15th Gear
6 °C (42.8 °F)	16th Gear
8 °C (46.4 °F)	17th Gear



WARNING



Travel speed should be such that complete control and machine stability is maintained at all times. Where possible, avoid operating near ditches, embankments and holes. Reduce speed when turning, crossing slopes, and on rough, slick, or muddy surfaces. Failure to comply could result in death or serious injury.

M109B



WARNING



Do not exceed implement transport speed or the speed rating on the implement tires. Review the implements Operator’s Manual for specifications. Failure to comply could result in death or serious injury.

M1219

When towing heavy loads and descending hills, the engine can reach an overspeed condition of **3000 RPM**. The fuel flow to the engine during this condition is slowed until engine rpm reaches **2600 RPM** to help protect the engine.

Automatic productivity management (APM)

Overview

In standard operation, engine RPMs are set by the throttle lever. Transmission gears are selected by up or down shift buttons. To maintain a desired ground speed, the operator adjusts both the gear setting and the throttle lever position.

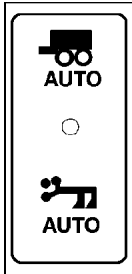

Automatic productivity management (APM) offers automatic continuous ground speed operation with the Powershift transmission. APM operates in two modes: APM field and APM road.

The operator uses this three position switch on the armrest console to select a mode of operation.

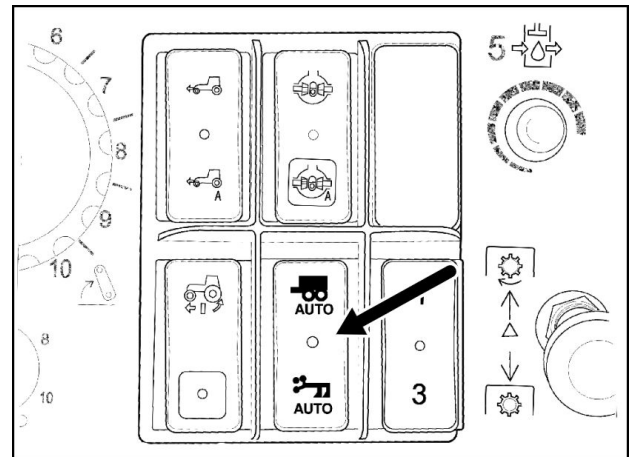

RCPH08CCH016AAC 1

Press the top of the switch (trailer icon) to select APM road.

Press the bottom of the switch (plow icon) to select APM field.

NOTE: This switch was formerly used for the autoshift feature which has been replaced by automatic productivity management.

In automatic productivity management (APM), the hand throttle is used to select the desired ground speed. The APM system then uses engine speed (RPMs) and transmission gears to attain and maintain the selected ground speed.

The minimum throttle lever position is the minimum possible vehicle speed. The maximum throttle lever position is the maximum possible vehicle speed. The speed range differs between APM Field and APM Road.

Once the operator picks the desired ground speed, the control system picks the gear and engine RPM for the vehicle.

If the vehicle is operating under a heavy load,

- the system selects a lower gear, and
- engine RPMs are increased to produce more horsepower.
- If vehicle load increases, the system selects lower gears and increases engine RPMs to maintain the desired ground speed and accommodate the vehicle load, until maximum power is reached.

Manual mode

To manually engage MFD, press and release the switch top. The MFD icon displays on the tractor instrumentation.

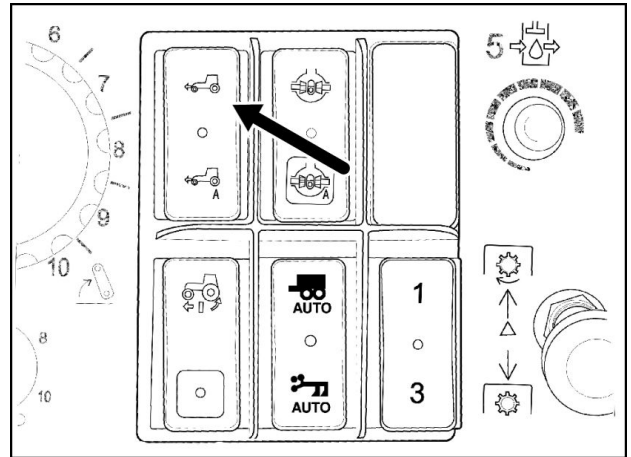

RCPH08CCH605AAC 3

To disengage MFD, move the switch to the center Off (0) position. The icon no longer displays.

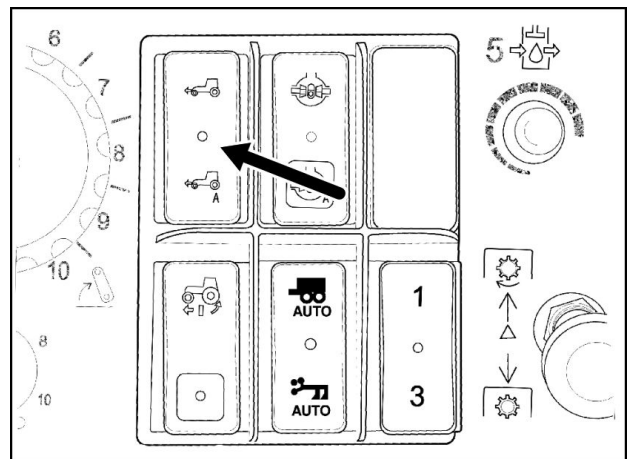

RCPH08CCH605AAC 4

Automatic mode

To engage Automatic mode, move the switch to the bottom position.

Automatic MFD engagement or disengagement is determined by hitch position, brake application, travel speed, tractor steering angle (when equipped with steering based traction control/Terra lock) and wheel slip (when equipped with radar/true ground speed sensor only).

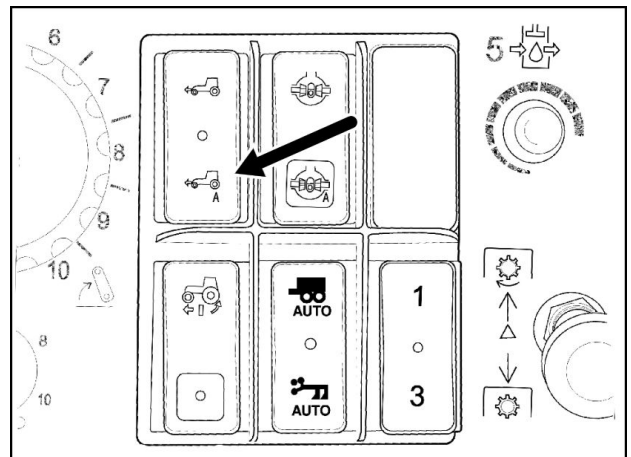

RCPH08CCH605AAC 5

Calibrating the suspended axle

If the message “Suspended Axle Cal Required” displays on the instrumentation, or when an operator suspects the suspended axle is not operating properly, perform the following calibration procedure. The tractor must be running for this procedure.



WARNING



Move the vehicle to an open area, free of obstacles and away from personnel. Transmission clutches are engaged during controller calibration, and the vehicle may move during calibration. The operator must be ready to take control of the vehicle at any time. Failure to comply may result in death or serious injury.

M588

NOTE: See “Entering the suspended axle screens” at the beginning of this section for instructions on navigating to the “TRANS F SUS” screen.



Press the INCR or DECR key from the “TRANS F SUS” screen until the “F SUS CAL” displays, and then press the PROG key.

Calibration runs automatically and the front suspension moves up and down through its complete mechanical range. When the procedure is complete, a screen similar to this displays. The * Pos (asterisk positive) indicates that calibration was successful. If a “Cal Failed” screen displays, the procedure must be performed again.

When calibration is successful, press the PROG key to exit the calibration screen.

Press the INCR or DECR key until the “F SUS Exit” screen displays, and then press PROG key to return to the normal operating screens.

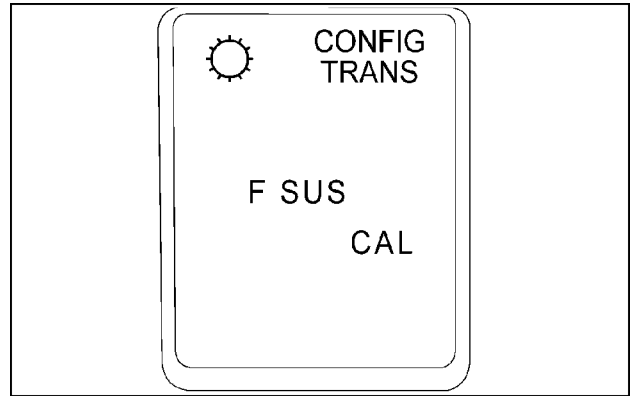

RCPH08CCH203AAC 9

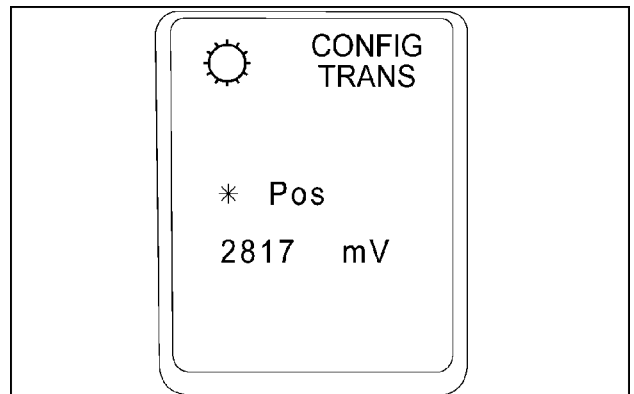

RCPH08CCH202AAC 10

Viewing pressures on the suspended axle

An operator may view various system pressures when they suspect the system is not correcting or calibrating properly. The piston pressure values will vary based on weight, load and distribution on the rod side versus the piston side. With no load on the tractor these values should be close to each other. If the cylinder pressures ever exceed the pressures of the associated accumulator, this is an indication that the suspension is not working.

6. Press the Record end of the switch momentarily to save the recorded sequence.

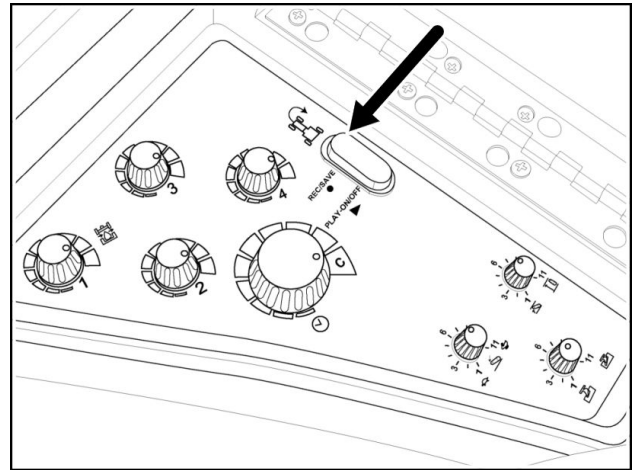

RCPH08CCH025AAA 3

As a sequence is recorded, the icons for the various functions display on the instrumentation as they are performed. Each new icon moves the previous icon downward on the display.

The table on the following page shows the icons used for the various functions.

When recording is complete, the instrumentation displays the previous performance screen.

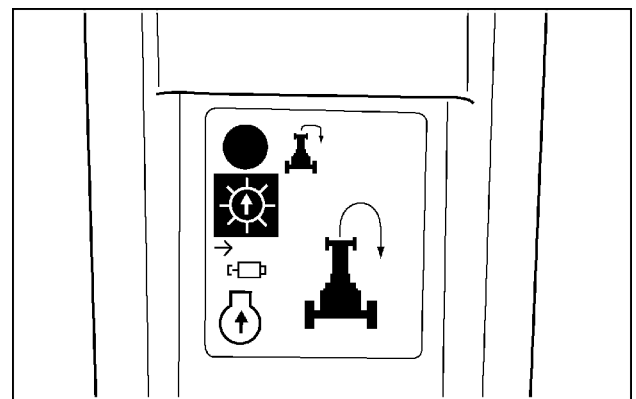

RCPH08CCH027AAA 4

Safety chain

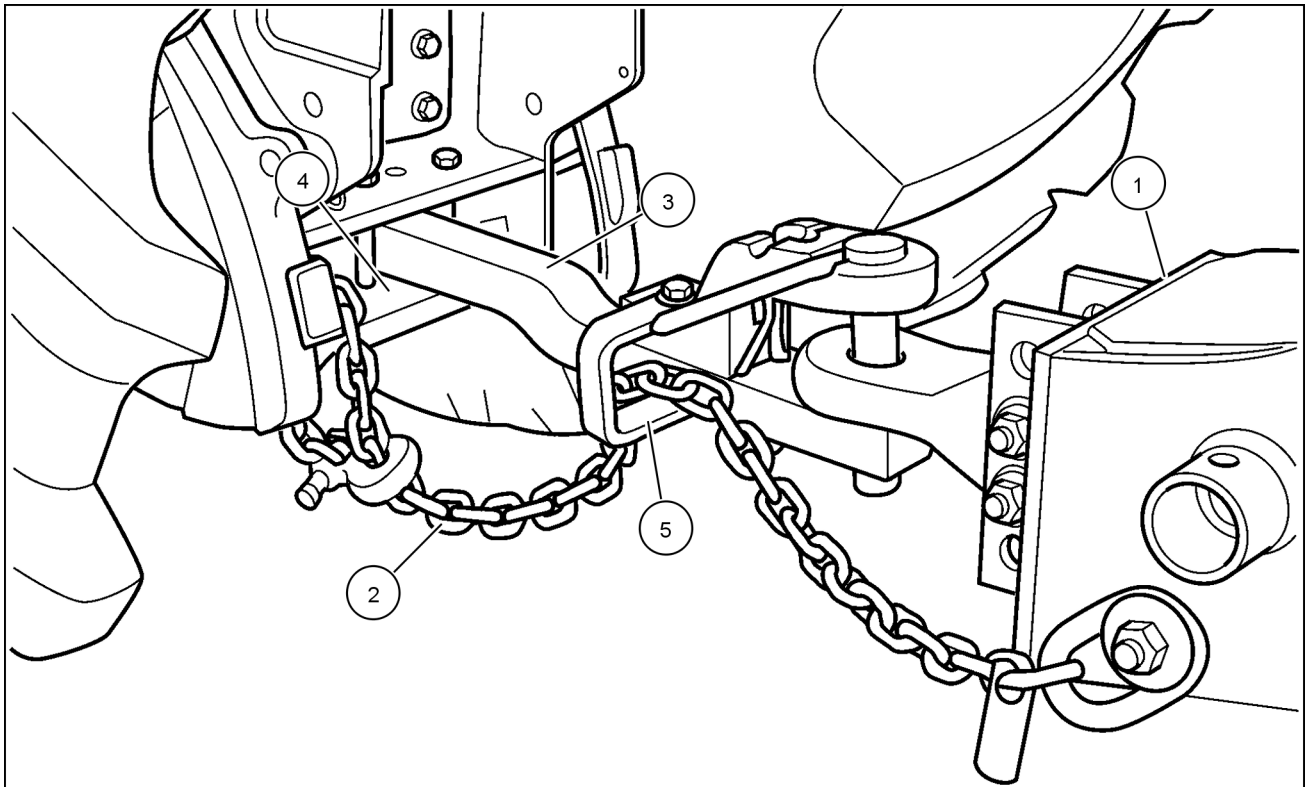

RCPH08CCH013FAB 1

- | | |
|--------------------|--------------------------|
| 1. Towed equipment | 4. Drawbar support |
| 2. Safety chain | 5. Chain support |
| 3. Drawbar | 6. Drawbar position bolt |

When towing equipment on a highway, use a safety chain as an auxiliary connection between the tractor and the towed equipment. The safety chain must have a rating greater than the gross load of the towed equipment. Connect the chain to the tractor drawbar support and the towed equipment as shown in the illustration. Check the adjustment of the safety chain by turning the tractor completely to the right and left. Adjust the chain as necessary.

The chain (2) must pass through the chain support (5), loop around and attach to the drawbar support (4). Do NOT fasten the chain to the chain support.

With the optional high capacity (heavy duty wide) drawbar, remove the drawbar retainer bolts (6) to gain sufficient clearance to install the safety chain. Install the chain and then reinstall the retainer bolts.

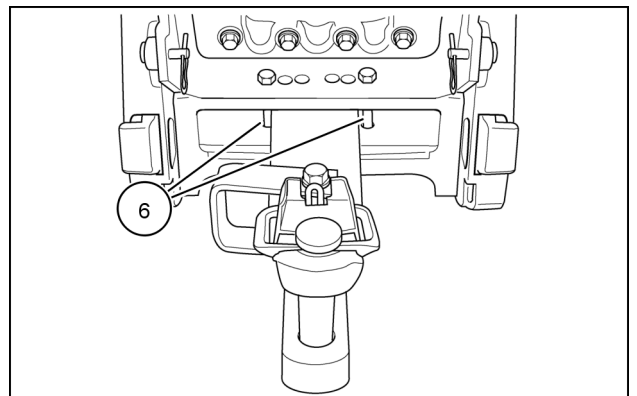

RCPH08CCH491AAB 2

Connecting the PTO

Some three point hitch mounted equipment such as mowers and snow blowers are driven with a direct drive shaft from the implement to the tractor PTO.

In all PTO applications the drawbar must be fastened in the center position on the drawbar support **(1)**.

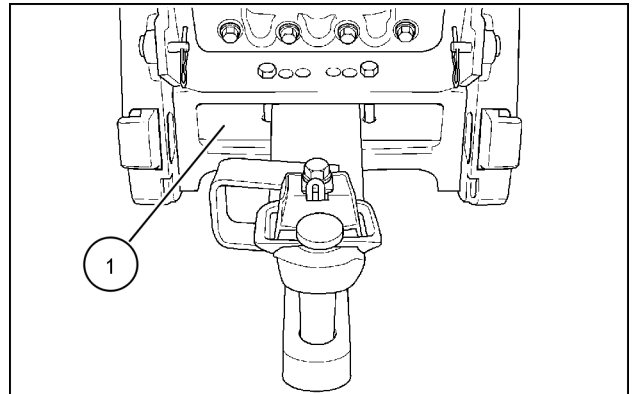

RCPH08CCH349AAC 1

Connect the implement to the tractor in the following sequence.

1. Connect the implement to the tractor first. Shut down the engine and remove the switch key.
2. Raise the PTO safety guard **(2)** for access to the PTO stub shaft **(3)**.
3. Rotate the PTO output shaft by hand to align the splines. Connect the implement drive shaft to the tractor PTO stub shaft **(3)**. Make sure the drive shaft yoke is locked securely to the PTO stub shaft. Lower the PTO safety guard.
4. Check the implement drive shaft for the correct length and for free telescopic movement. The correct length is important to prevent the PTO drive shaft from hitting bottom or separating in any tractor or implement operating position.
5. Check the drive shaft integral shields for free rotation without any interference. If the PTO shield is damaged or does not rotate, repair or replace the shield before operating the PTO.
6. Make sure all shields are in position and in good condition. Never operate the PTO unless the PTO safety guard is down and correctly positioned.
7. Keep the drive line as straight as possible.

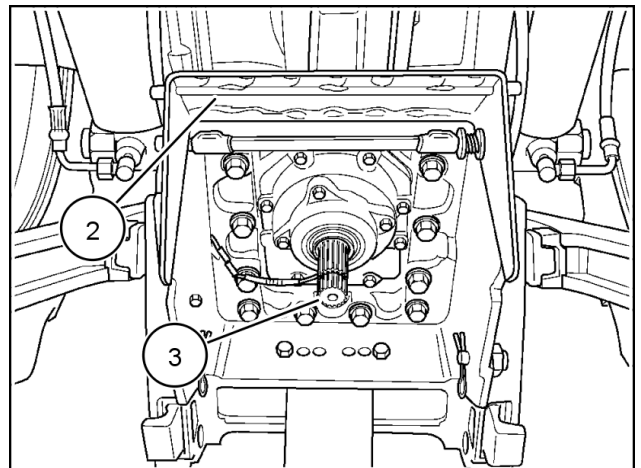

RCPH08CCH350AAC 2

- When the PTO is engaged, engine hours are replaced with PTO information. The PTO screen displays for 3 seconds on engagement showing the PTO type (1), 540 RPM or 1000 RPM as equipped, current PTO speed (2), and engagement rate (3): auto or heavy.
- If necessary, adjust the Throttle lever position slowly until the correct PTO speed is indicated on the display

NOTE: The PTO clutch disengages automatically to avoid damage to clutch components if the clutch slips for more than 5 seconds. Reduce PTO load and reset the PTO by turning the PTO switch Off and then On.

NOTE: If the PTO speed sensor detects PTO shaft speed above 1171 RPM (for the 1000 RPM shaft), or 632 RPM (for the 540 RPM shaft), an alarm sounds. 1000 PTO RPM or 540 PTO RPM is reached at 1800 RPM engine speed.

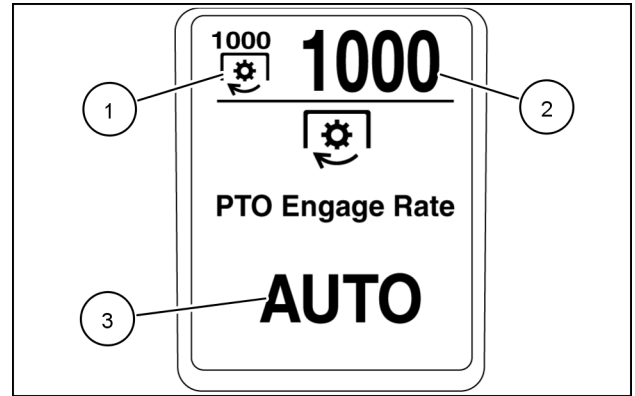

RCIL08CCH020AAA 4

PTO controller software monitors the PTO load during engagement and displays messages to the operator based on the sensed PTO load. The software now distinguishes between normal and heavy loads for engagement. The heavy load setting is intended for grinder/mixers, large balers, and other implements which can be started when loaded.

If the software detects a heavy PTO load when the switch is engaged, the engagement process stops and a message "PTO Load Heavy? Confirm Engage Rate" displays for 10 seconds on the tractor instrumentation.

NOTE: The number on the screen is the count down timer for the 10 seconds.

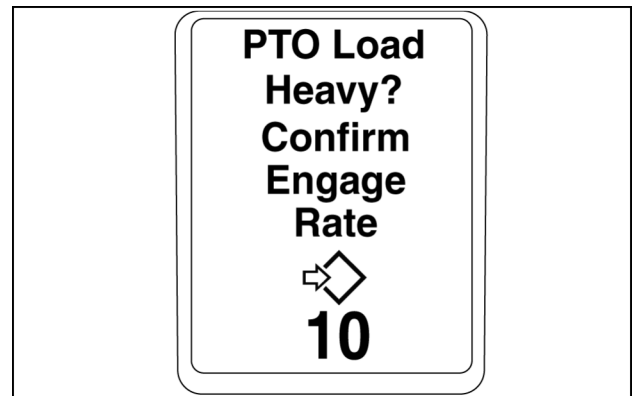

RCIL08CCH021AAA 5



Press the PROG key or wait the 10 seconds for the next screen to display. The PTO will not engage until the operator provides a response.

The next screen displays with "Heavy" highlighted. The PTO controller changed the engagement rate to "Heavy" and is asking the operator to confirm the setting.



Press the PROG key on the key pad to accept the "Heavy" setting.



Press the RESET key on the key pad to reject the setting.

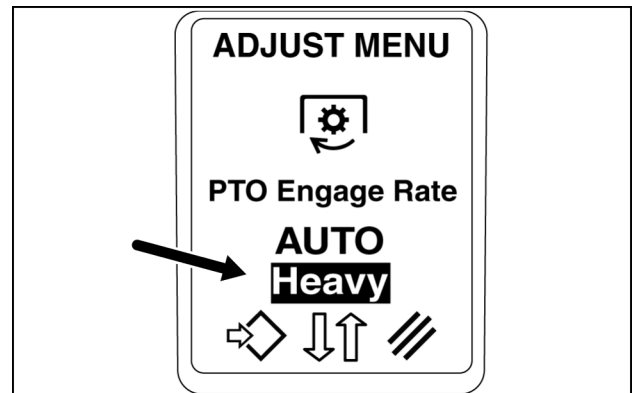

RCIL08CCH022AAA 6

4. After adjusting lower link height, return the locking collar to its lowered locked (4) position.

NOTE: The locking collars must be returned to their locked position after adjusting the lower links.

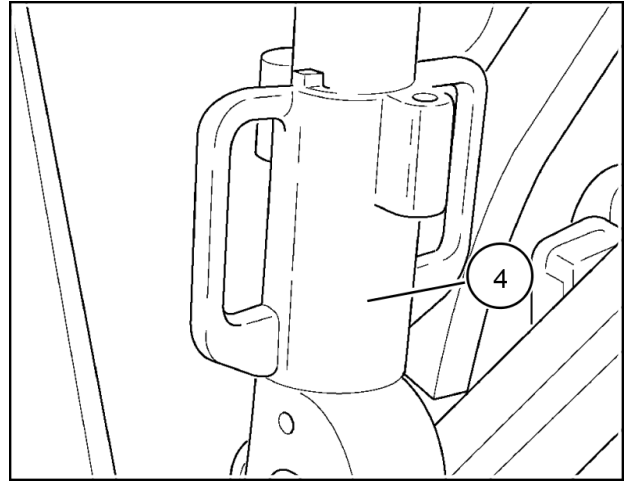

RCPH08CCH343AAC 4

5. Move the PTO safety guard (7) to the lower detent position to avoid damage when hitch is lowered.

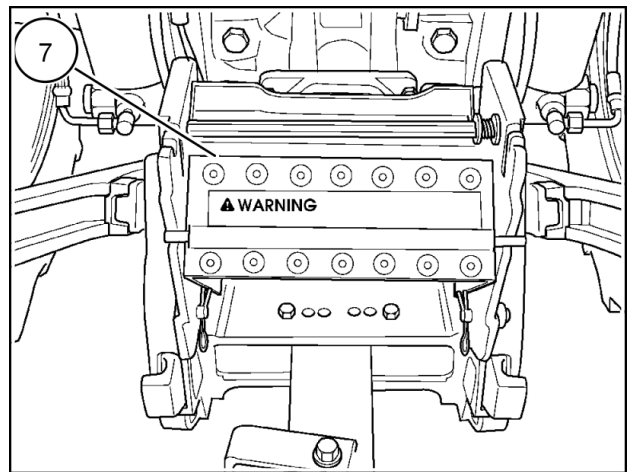

RCPH08CCH351AAC 5

6. Install the upper link (5) in the proper hole of the upper link bracket (6) for the application:

- A. Lower hole – tillage, increase kick, best load transfer, best angle of attack for quick soil penetration.
- B. Middle hole – PTO driven equipment or as required for level operation.
- C. Top hole (three hole only if equipped) – high clearance required.

IMPORTANT: Restriction bolts (if equipped) must be installed in the lift links if the upper link is in the lower (A) or middle (B) holes. Restriction bolts must be installed in the upper link if the upper link is installed in the top (C) hole. Damage to hitch components will occur if restriction bolts are not installed.

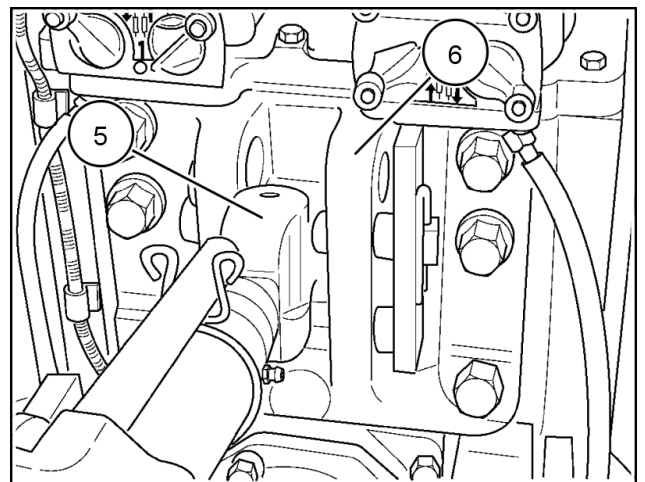

RCPH08CCH335AAC 6

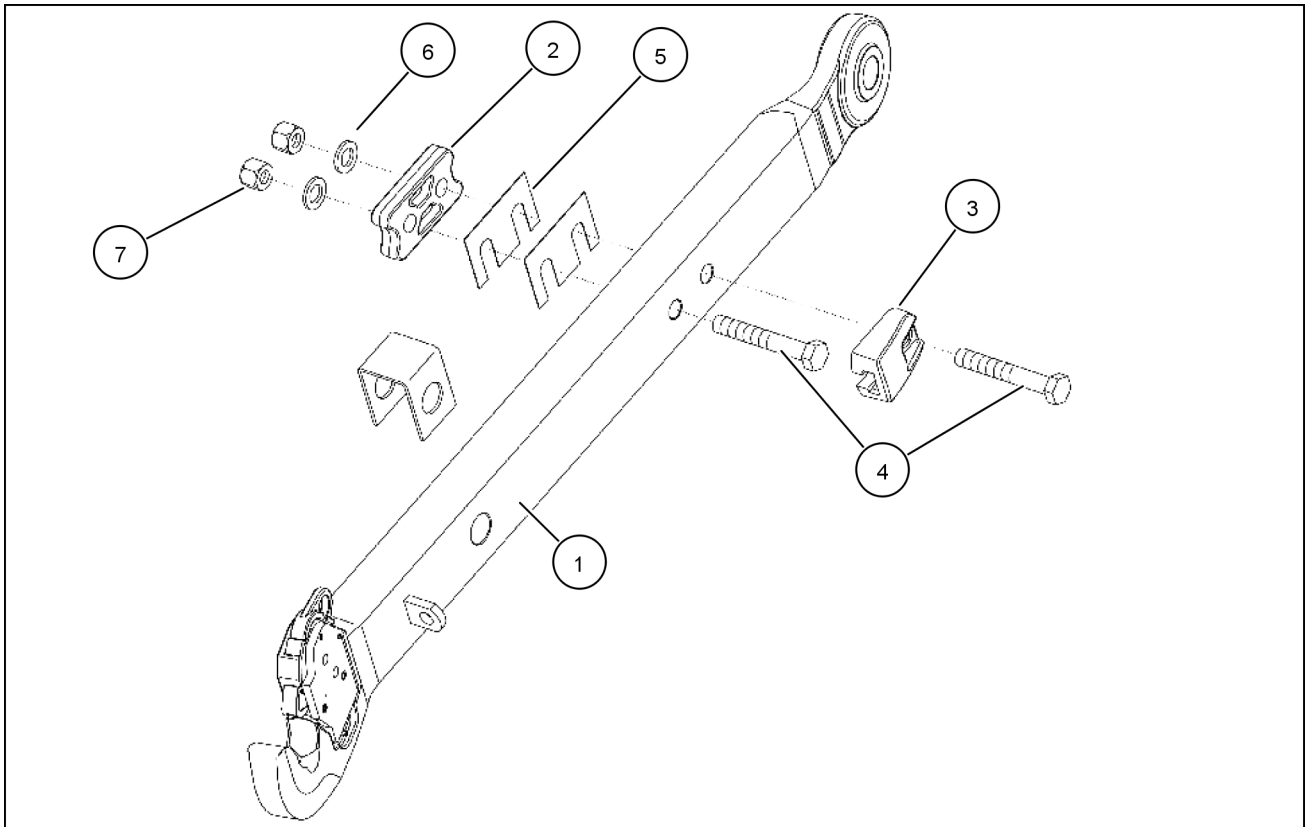

RCPH08CCH283AAC 2

- | | | | |
|------------------------|---------------------------------------|--|--------------------------|
| 1. Lower link assembly | 5. Shim (in stored position) | 3. Sway bumper cam | 7. Nut prevailing torque |
| 2. Spacer | 6. Washer 22 mm x 37 mm x 4 mm | 4. Bolt hex head 20 mm x 130 mm | |

When operating Category IIIN equipment, install the bumper (3) on the lower links as shown. Install spacer (2) and shims (5) on the outside of the lower links (1).

Shims are available to let the operator adjust the amount of lateral free-play between the hitch and tractor when the hitch is in either the Rigid (No Sway) position or Transport.

When adjusting the free play, an equal number of shims must be used on each lower link. The adjustment must be made with the sway blocks in the rigid position and the hitch raised to transport position.

The lower links must be able to move freely without binding against the sway blocks throughout the full stroke of the hitch when an implement is attached.

Add shims between the spacer and sway bumper as needed.

IMPORTANT: Be certain that the hitch category setting is proper for the implement in use. Damage to the hitch linkage can occur if a Category II implement is attached to the tractor with the hitch in Category III setting.

Converting to III implements without standard quick coupler hole

To convert to the Cat III position for implements without a standard quick coupler hole,

1. Remove the two IVN spacers from the inside lower links.
2. Install the III top hook in the upper set of holes with two **20 mm x 140 mm** bolts for the upper holes and two **20 mm x 90 mm** socket head screws in the lower holes.
3. Torque the bolts to **675 Nm (498 lb ft)**.

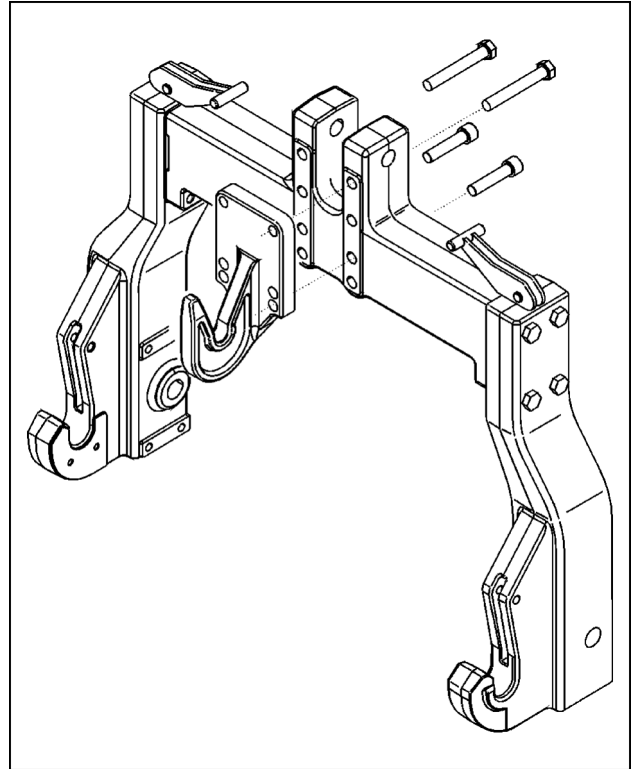

RCPH08CCH461BAC 9

CLICK HERE TO **DOWNLOAD** THE COMPLETE MANUAL

- Thank you very much for reading the preview of the manual.
- You can download the complete manual from: www.heydownloads.com by clicking the link below



- Please note: If there is no response to CLICKING the link, please download this PDF first and then click on it.

CLICK HERE TO **DOWNLOAD** THE COMPLETE MANUAL

Load control operation

The load control knob sets the depth of the implement relative to load on the tractor. Turn the knob clockwise to increase tractor load and implement depth. Turn the knob counterclockwise to decrease tractor load and implement depth.

Settings 1-4 are used for negative/draft load conditions, and settings 5-10 for positive/draft load conditions.

With negative load conditions, the implement applies downward weight stress on the hitch lower links and drawing stress on the top link, as with some semi-mounted and lightweight implements.

With positive load conditions, the implement applies drawing stress on the hitch lower links and downward weight stress on the top link, as with most fully-mounted ground engaging implements.

IMPORTANT: Tractor speed must exceed **0.8 km/h (0.5 mph)** for load control to function. Do not adjust the load control knob to a lighter load setting (1-5) while the tractor is stationary. This may cause significant hitch movement when the tractor moves again.

NOTE: At the lighter load settings (1-5), some implements may not lower when operating in load control mode. Move the load control knob clockwise to increase load setting and lower the implement.

NOTE: Slip limit control, if equipped, must be turned Off during hitch setup. Once the hitch is setup, slip limit control can be turned On.

To operate in load control:

1. Depress the top of the hitch up/down switch (1) to lower the hitch. With the hitch position control (2) fully counterclockwise, turn the load control knob (2) counterclockwise to decrease the load setting until the hitch begins to raise.

NOTE: In fields with intermittent hard and soft soil conditions, use the hitch position control to establish the bottom depth for implement penetration – some position other than full down. This prevents the implement from penetrating too deeply in soft or sandy soil areas.

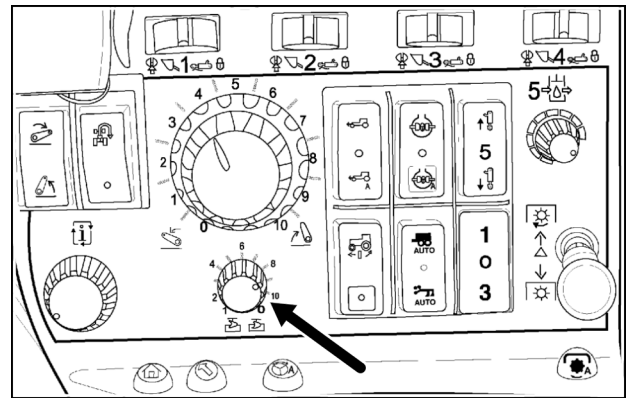

RCPH08CCH857AAC 1

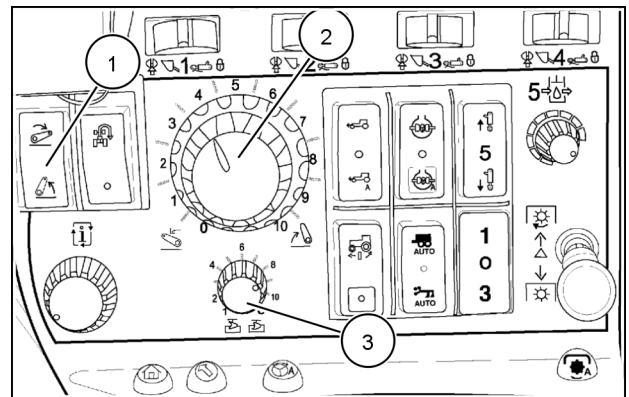

RCPH08CCH857AAC 2

Standard drawbar – Magnum 275 and Magnum 305 and 335 – positions/capacities

PTO shaft diameter	PTO RPM	Drawbar position*					
		"A"	"B"	"C"	"D"	"E"	"F"
35 mm (1.375 in)	540 or 1000	303 mm (11.9 in)	355 mm (14.0 in) 540 PTO	407 mm (16.0 in) 1000 PTO	459 mm (18.1 in)	549 mm (21.6 in)	604 mm (23.8 in)
44 mm (1.75 in)	1000	354 mm (13.9 in)	406 mm (16.0 in)	458 mm (18.0 in)	510 mm (20.1 in) 1000 PTO	600 mm (23.6 in)	655 mm (25.8 in)

* Refer to the implement operator's manual for correct drawbar position.

Maximum static vertical drawbar load		
"A"	4140 lb	1880 kg
"B"	4140 lb	1880 kg
"C"	4140 lb	1880 kg
"D"	4140 lb	1880 kg
"E"	4140 lb	1880 kg
"F"	3890 lb	1760 kg

Hose couplers

The tractor is equipped with ISO 5675 standard female couplings. These couplings will fit standard male hose couplers made to ASAE S366, SAE J1036 or ISO Standard 5675. Your dealer has the following ASAE standard male couplers:

Part number	Thread size	Thread
1272399C2	7/8-14 inch	UNF SAE standard
1272770C2	1/2-14 inch	NPTF
1285718C2	3/4-16 inch	UNF SAE standard

Your dealer can also supply hose fittings or adapters to connect different combinations of implements to the standard male coupler.

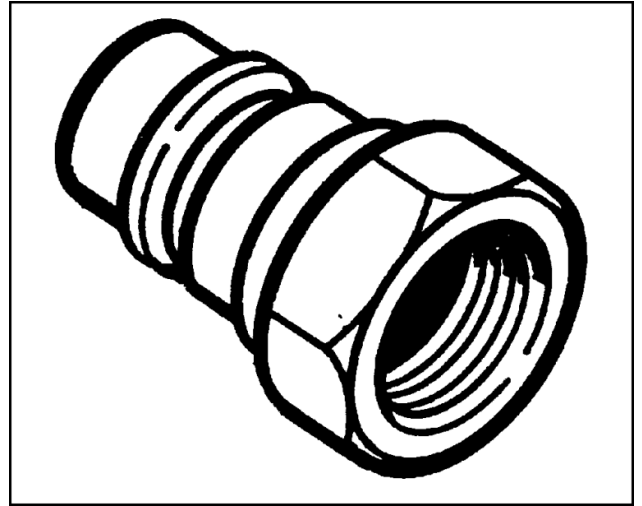

RCPH08CCH289AAC 2

No float position

To operate in a "No float" condition, rotate the function control to the float lockout position. In this position, the control lever cannot be moved into the "float" position.

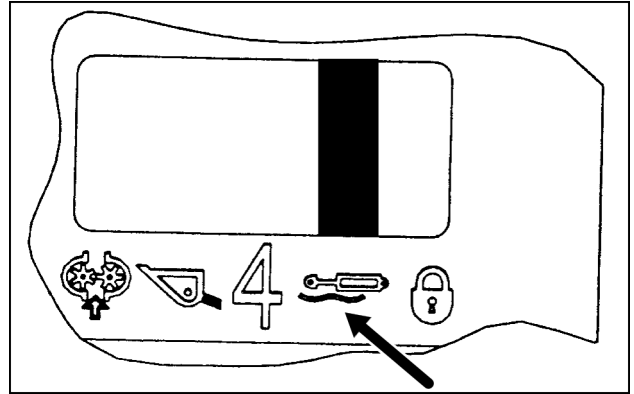

RCPH08CCH878AAC 4

Loader position

NOTE: Turn the Timer control for the remote circuit fully counterclockwise before using the loader function.

When operating a front end loader, the function control must be rotated to the loader position. This prevents the control lever from moving into the raising detent position. Rotate the timer control for the remote fully counterclockwise (minimum time). This prevents the loader from lowering more than desired.

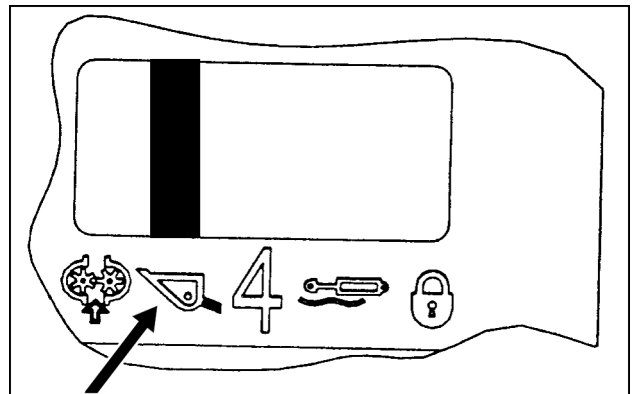

RCPH08CCH880AAC 5



WARNING



When doing a loader operation, the remote function control **MUST** be in the loader position. This will prevent the remote control lever from going into a timed "RAISE" detent. A timed "RAISE" detent during loader operation can cause uncontrolled loader operation which may cause load dumping. Uncontrolled loader operation in a full height raising of the loader can cause load dumping which may result in injury or death.

M586A

Hydraulic motor operation

With tractor running, rotate the flow control counterclockwise to the minimum position on the remote circuit for the connected motor.

NOTE: The remote control lever must be in neutral position on tractor start-up.

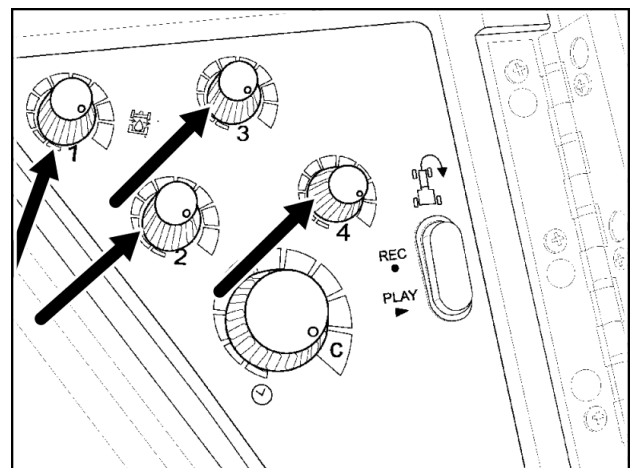

RCPH08CCH301AAC 6

Ballasting guide – standard and suspended MFD (Initial)

Approximate Unballasted Weight with Standard Equipment, No Operator and 75 Percent Fuel				
Model	MFD, Rear Singles		MFD Rear Duals	
	Split, Lbs/HP	Weight (Lbs)	Split, Lbs/HP	Weight (Lbs)
215	39/61, 119	8190 F 12 600 R 20 790 T	36/64, 130	8190 F 14 600 R 22 790 T
245	39/61, 104	8190 F 12 600 R 20 790 T	36/64, 114	8190 F 14 600 R 22 790 T
275	40/60, 95	8660 F 12 780 R 21 440 T	37/63, 104	8660 F 14 730 R 23 390 T
305	40/60, 84	8680 F 12 790 R 21 470 T	37/63, 92	8680 F 14 740 R 23 420 T
335	41/59, 81	9144 F 13 110 R 22 254 T	38/62, 88	9144 F 15 060 R 24 204 T

F = Front Axle Weight, R = Rear Axle Weight, T = Total Tractor Weight

MFD with Towed or semi-mounted Implements (35/65 Split)								
Model	110 Lbs/HP, 5.5 mph +		120 Lbs/HP, 5.0 mph		130 Lbs/HP, 4.5 mph -		135 Lbs/HP, 4.5 mph -	
	Singles	Duals	Singles	Duals	Singles	Duals	Singles	Duals
215	n/a	n/a	n/a	n/a	H	Unballast	H	G
245	n/a	n/a	A, H	Unballast	A, G, H	A, G	n/a	A, C, G, H
275	H	Unballast	A, G, H	A, G	n/a	A, C, G, H	n/a	n/a
305	A, G, H	A, H	n/a	A, D, 2xH	n/a	B, D, G, 2xH	n/a	n/a
335	A, G, H	A, H	n/a	A, D, 2xH	n/a	B, D, G, 2xH	n/a	B, J, 2xG, 2xH

MFD with Fully or High Vertical Load Implements (40/60 Split)								
Model	110 Lbs/HP, 5.5 mph +		120 Lbs/HP, 5.0 mph		130 Lbs/HP, 4.5 mph -		135 Lbs/HP, 4.5 mph -	
	Singles	Duals	Singles	Duals	Singles	Duals	Singles	Duals
215	n/a	n/a	Unballast	n/a	A, G	n/a	n/a	A, C, G, H
245	A	n/a	A, C, G	A, C	A, D, G, H	A, D, G	n/a	n/a
275	A, G	A	A, D, G, H	A, D, G	n/a	B, D, H	n/a	n/a
305	A, D, G, H	A, D, H	n/a	B, D, G, H	n/a	B, E, G, 2xH	n/a	n/a
335	A, D, G, H	A, D, H	n/a	B, D, G, H	n/a	B, E, G, 2xH	n/a	B, J, 2xG, 2xH

Code	Description	Front Wt, +/-	Rear Wt, +/-
A	Small weight frame	+475 Lbs	-135 Lbs
B	Large weight frame	+1135 Lbs	-310 Lbs
C	Front weight - 6 x 100 Lb	+875 Lbs	-280 Lbs
D	Front weight - 10 x 100 Lb	+1460 Lbs	-465 Lbs
E	Front weight - 18 x 100 Lb	+2630 Lbs	-840 Lbs
F	Rear wheel weight - 2 x 200 Lb	0 Lbs	+400 Lbs
G	Rear wheel weight - 2 x 500 Lb	0 Lbs	+1000 Lbs
H	Rear wheel weight - 2 x 1000 Lb	0 Lbs	+2000 Lbs
J	Front weight - 18 x 120 Lb	+3175 Lbs	-1015 Lbs
n/a	Weight split is not achievable		
Unballast	No ballast needed to achieve setting	0 Lbs	0 Lbs

Metric – Rear tires – Used as singles

NOTE: Load and inflation charts are for travel speeds up to **50 km/h (30 mph)**, except as noted. Last value in the chart is the maximum inflation pressure for that particular tire.

Maximum Rear Tractor Weight (kg) At Various Cold Inflation Pressures (kPa)																
40	60	70	80	100	110	120	140	150	160	165	180	190	210	240	280	320
Tire Size - 320/90R54 (149 LI)																
-	2570	2800	3000	3400	3650	3900	4240	4480	4720	4790	5000	5080	5230	5450	6000	6500
Tire Size - 380/90R46 (149 LI)																
-	3000	3300	3500	4000	4300	4600	5000	5300	5600	5650	5800	5980	6240	6500	-	-
Tire Size - 380/90R50 (151 LI)																
-	3200	3400	3700	4240	4480	4720	5300	5550	5800	5890	6150	6230	6450	6900	-	-
Tire Size - 380/90R54 (152 LI)																
-	3300	3600	3900	4360	4680	5000	5450	5730	6000	6080	6300	6500	6800	7100	-	-
Tire Size - 420/80R46 (151 LI)																
-	3200	3500	3700	4240	4550	4860	5300	5550	5800	5890	6150	6330	6600	6900	-	-
Tire Size - 480/80R42 (151 LI)																
-	3700	4000	4360	5000	5300	5600	6300	6600	6900	-	-	-	-	-	-	-
Tire Size - 18.4R46 (3*) - Maximum Speed 40 km/h (25 mph) For R-2 Only																
-	3800	4000	4480	4860	5300	5600	6000	6300	6700	6800	7100	7300	7750	-	-	-
Tire Size - 480/80R46 (158 LI)																
-	3900	4240	4600	5150	5480	5800	6500	6800	7100	7200	7500	7630	7940	8500	-	-
Tire Size - 480/80R50 (159 LI)																
-	4120	4480	4720	5450	5800	6150	6900	7200	7500	7560	7750	8000	8380	8750	-	-
Tire Size - 20.8R42 (2* or 155 LI) - Maximum Speed 40 km/h (25 mph) For R-2 Only																
-	4360	4600	5150	5600	6150	6500	6900	7300	7550	--	-	-	-	-	-	-
Tire Size - 520/85R42 (157 LI)																
-	4480	4860	5150	6000	6350	6700	7500	7880	8250	-	-	-	-	-	-	-
Tire Size - 520/85R46 (158 LI) - Maximum Speed 40 km/h (25 mph) For R-2 Only																
-	4600	5000	5450	6150	6530	6900	7750	8130	8500	-	-	-	-	-	-	-
Tire Size - 620/70R42 (160 LI)																
-	4860	5300	5800	6500	6900	7300	8250	8630	9000	-	-	-	-	-	-	-
Tire Size - 620/70R46 (162 LI)																
-	5150	5600	6000	6900	7330	7750	8500	9000	9500	-	-	-	-	-	-	-
Tire Size - IF650/85R38 (179 LI)																
-	-	-	8500	9700	10300	10900	12150	12780	13400	13550	14000	14300	14820	15500	-	-
Tire Size - 710/70R38 (166 LI)																
-	5800	6300	6700	7750	8250	8750	9750	10180	10600	-	-	-	-	-	-	-
Tire Size - 710/70R42 (168 LI)																
-	6000	6500	7100	8000	8500	9000	10000	10600	11200	-	-	-	-	-	-	-
Tire Size - 710/70R42 (173 LI)																
-	6000	6500	7100	8000	8500	9000	10000	10600	11200	11340	11750	12030	12480	13000	-	-
Tire Size - 800/70R38 (173 LI)																
-	6900	7500	8250	9250	9930	10600	11600	12300	13000	-	-	-	-	-	-	-

Wheel slip and power hop performance

Once the ballast is added and tire pressures are adjusted for the load, operate the tractor in the field and observe the performance. The following information will help adjust the “Initial Setup” for peak performance.

Ideal wheel slip for an MFD tractor equipped with radial tires is **7 - 9 %**.

To reduce wheel slip

- Increase travel speed.
- Reduce load.
- Increase ballast.

To increase wheel slip:

- Decrease ballast
- Increase load.
- Decrease travel speed.

Wheel slip

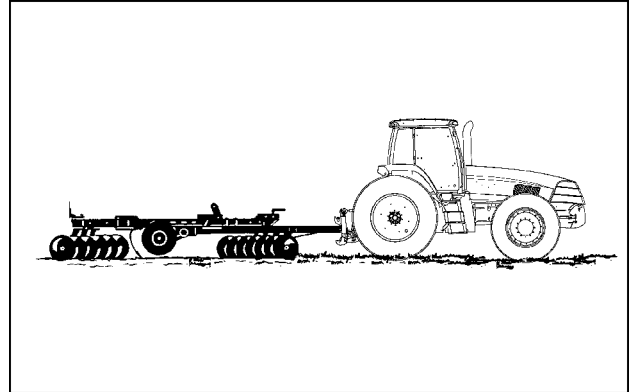

RCIL08CCH016AAB 1

Measuring wheel slip with the instrumentation

Tractors must be equipped with radar/true ground speed sensor and performance instrumentation to calculate and display wheel slip. The amount of wheel slip is indicated numerically in the center of the display. Wheel slip is displayed anytime the % Slip key is pressed on the key pad.

NOTE: The correct rolling radius for the tires must be programmed into the tractor instrumentation for tire slip read-out to be accurate. See changing tire radius in Chapter 3.

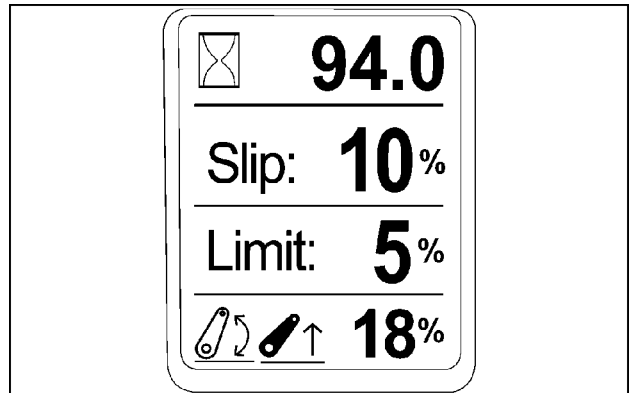

RCIL08CCH018AAB 2

The radar/true ground speed sensor must be adjusted properly for the slip measurement to be accurate. Refer to radar sensor calibration in Chapter 3.

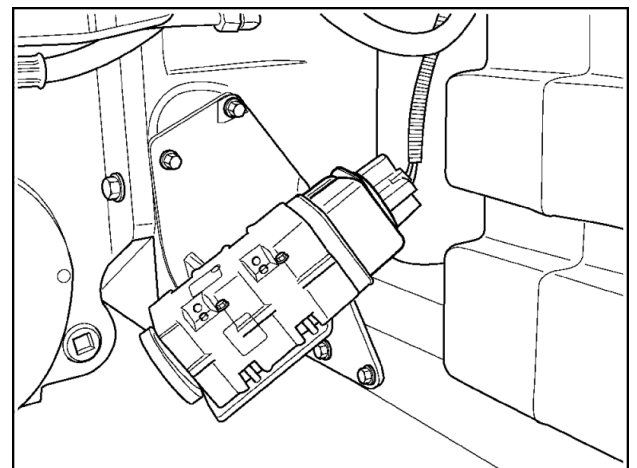

RCPH08CCH487AAC 3

Steering and oscillation stops

Tractors with mechanical front drive (MFD) are equipped with steering and oscillation stops. The steering and oscillation stops are used to give the required steering clearance between the front tires and tractor frame. The front tire size and tread width in use determines the required steering and oscillation angles.

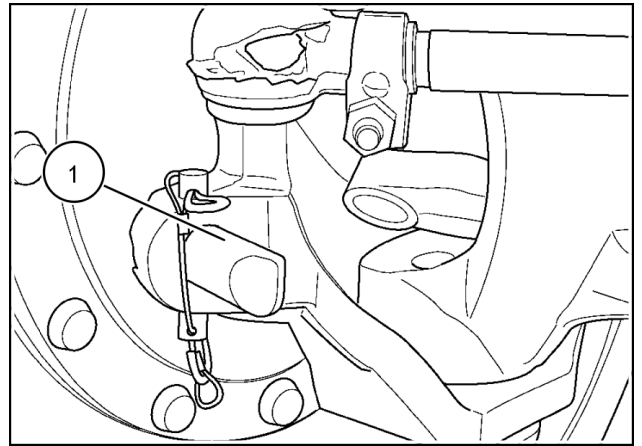

RCPH08CCH504AAC 1

Steering stop

Each adjustment hole in the steering stop is identified with an arrow and a number. With the arrow pointing toward the wheel, the number indicates the turn angle when the mounting pin is installed in that hole.

With the pin installed in the desired hole, the angle number will be visible outside the steering knuckle casting. The steering stop can be installed in either direction depending on the tire size and tread width being used.

The standard stop **(A)** offers six steer stop settings: 34, 39, 44, 46, 50 and 55. An optional long stop **(B)** offers six steer stop settings: 17, 20, 25, 28, 32 and 33. See your dealer to purchase the optional steer stops.

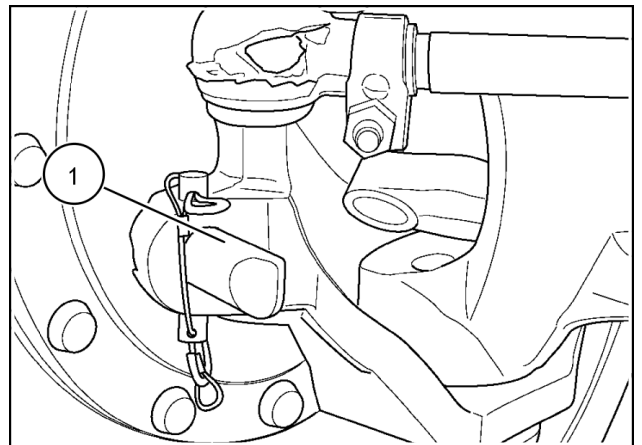

RCPH08CCH504AAC 2

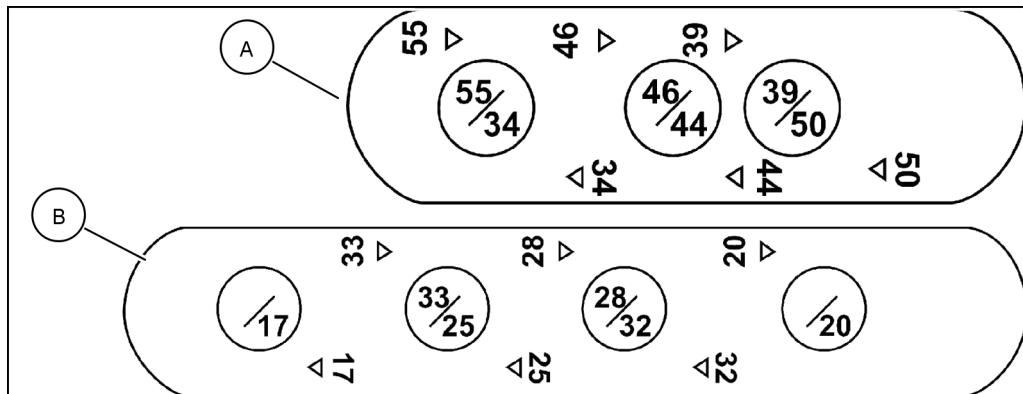

RCPH08CCH917EAC 3

Dual wheel installation

Duals may be desirable when factors such as stability, flotation, or additional traction or load carrying capacity are important.

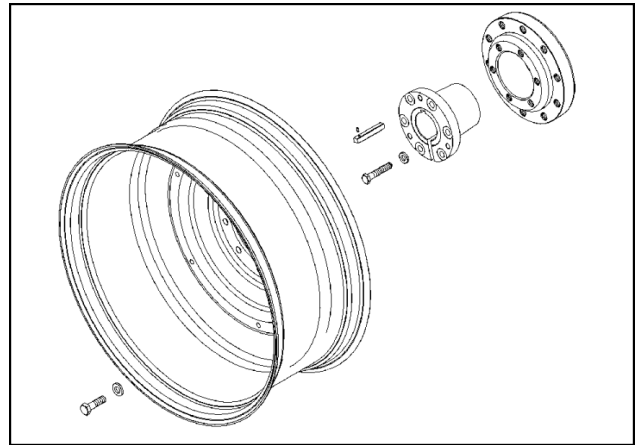

RCPH08CCH589AAC 5

A special tool kit **380040134** is available from your dealer to torque wheel hardware when the clearance is minimized due to inner and dual tire settings. The kit contains these components, which may be ordered separately:

Bushing bolt tool	CAS 2725 30 mm
Wheel bolt tool	CAS 2726 34 mm
Wheel bolt tool	280000518 32 mm

- Check bolt torque after the first 30 minutes of field use, every 10 hours until torques stabilize and every 300 hours thereafter.

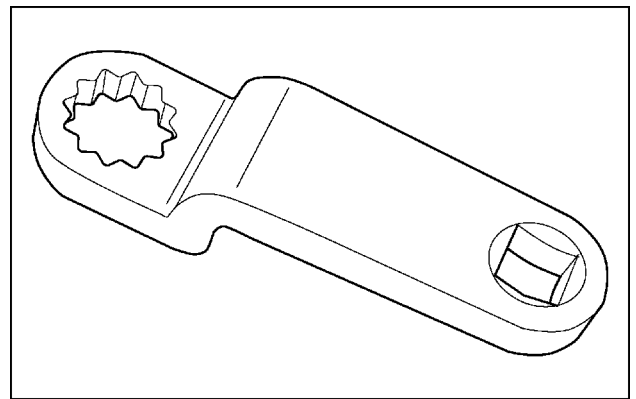

RCPH08CCH469AAC 6

IMPORTANT: Once the inner hub wheel and bushing bolts are properly torqued, drive forward and in reverse while turning and braking. This will further seat the wheel joints. Stop the tractor and torque to proper values. Install outer wheel and repeat driving, turning, braking and torque procedure.

Location	Torque
1. 6 bushing bolts	300 - 350 Nm (220 - 260 lb ft)
2. 10 hub bolts	530 - 570 Nm (390 - 420 lb ft)

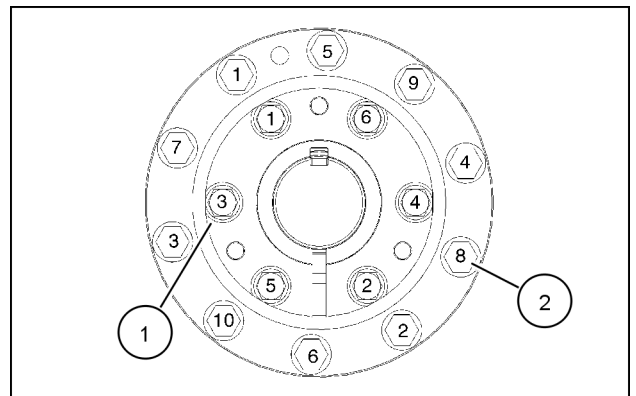

RCPH08CCH608AAC 7

Dual rear wheels spacer requirement – inner row set

Use the tables on the following pages to determine if a dual spacer is required for a specific row spacing with dual tires. Spacers are available in **127 mm (5.0 in)**, **254 mm (10.0 in)**, **330 mm (13.0 in)** or **381 mm (15.0 in)** lengths. A **38 mm (1.5 in)** spacer extension is also available for use between the spacer and the wheel disc only.

Inside wheel turned in, dual wheel turned out

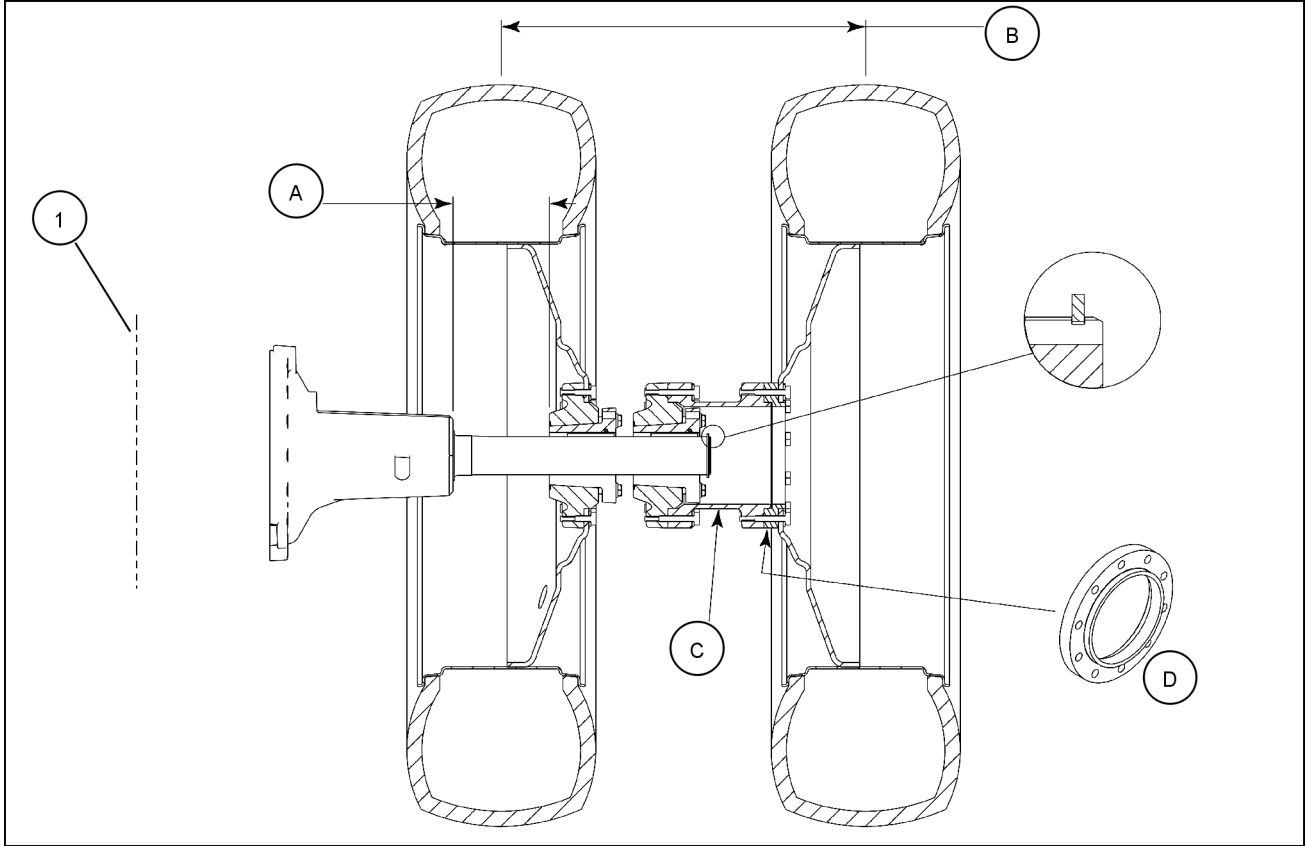

RCPH08CCH599AAC 5

1. Tractor centerline

Minimum clearance, axle housing to hub

Axle length	Axle diameter	A Minimum clearance, axle housing to hub
3050 mm (120 in)	102 mm (4.0 in)	52 mm (2.06 in)
3050 mm (120 in)	115 mm (4.4 in)	57 mm (2.25 in)

- B. Maintain minimum dual spacing between tires
- C. Dual spacer, **254 mm (10.0 in)** shown
- D. Spacer extension, **38 mm (1.5 in)**

Tire and rim service

Tire and rim repair



WARNING



DO NOT weld to a wheel or rim until the tire is completely removed. Inflated tires can generate a gas mixture with the air that can be ignited by high temperatures from welding procedures performed on the wheel or rim. This condition can exist whether tires are inflated or deflated. Removing the air or loosening the tire on the rim (breaking the bead) will **NOT** eliminate the hazard. The tire **MUST** be completely removed from the wheel or rim prior to welding the wheel or rim.

SC134



WARNING



Do not remove, install or make repairs to a tire on a rim. Take the tire and rim to a tire shop where persons with special training and special safety tools are available. If the tire is not in correct position on the rim, or if too full of air, the tire bead can loosen on one side and cause air to leak at high speed and with large force. Because the air leak can thrust the tire in any direction, and with much force, you will be in danger of injury.

M169B

Always have a qualified tire mechanic service the tires and rims on this machine. If the tire has lost all air pressure, take the tire and rim to a tire shop for service. The use of correct equipment and correct procedures will prevent accidents. Explosive separation of the tire can cause serious injury.

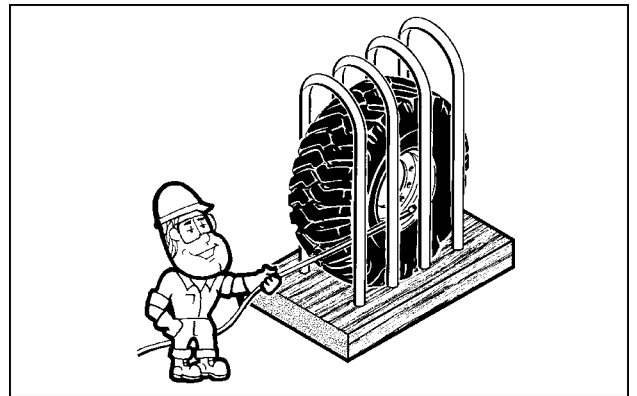

RCIL08CCH014AAB 1

Tire installation

To get the traction and cleaning action of the lugs, the tires must be installed on the wheels so the tread is turning as shown. Do not try to remove, repair or install a tractor tire on a rim.

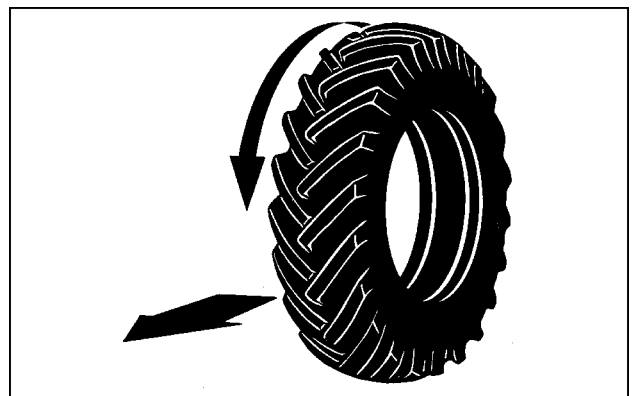

RCIL08CCH015AAB 2

Electrical component location

Cab fuse and relay location

Fuses (1) and relays (2) are located to the rear of the operators seat, under the floor cover mat and metal cover.

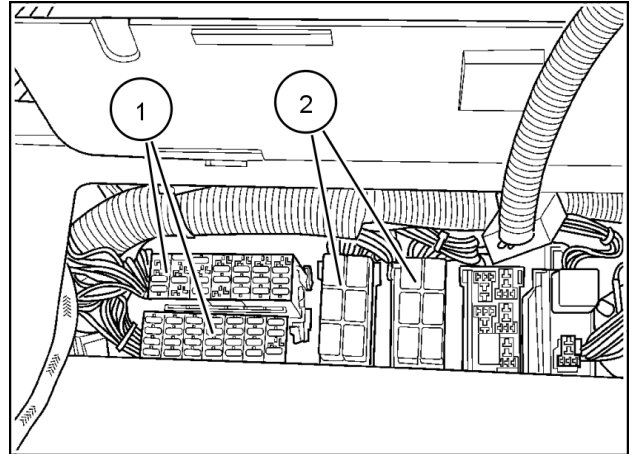

RCPH08CCH787AAC 1

Cab fuse identification

50		51	FRT 15A	52	REAR 20A	53	30A	54		55		56	5A
43	TRCU 15A	44	TRCU 15A	45		46	30A	47	30A	48	20A	49	30A
36	15A	37	5A	38	15A	39	15A	40	ECU 10A	41	20A	42	10A
29	10A	30	10A	31	ISO 11783 10A	32	TRCU 10A	33	10A	34	5A	35	5A
22	10A	23	15A	24	10A	25		26	10A	27	20A	28	20A
15	GOV 25A	16	ICU 5A	17	5A	18	10A	19	10A	20	20A	21	10A
8	+	9	15A	10	15A	11	20A	12	30A	13	30A	14	5A
1	ELE GOV 5A	2	5A	3	25A	4	10A	5		6	10A	7	10A

RCIL08CCH002EAA 2

Fuse no.	Circuit	Fuse amp
1	Electronic governor	5
2	Constant engine speed	5
3	Rear fender work lights	25
4	Belt line work lights	10
5	Blank	
6	Work light/head light interlock	10
7	Battery power to key switch	10
8	Headliner shelf auxiliary power/3-pin/cigar outlets (1)	20
9	Seat power & operator presence	15
10	Cab pressurizer blower	15
11	Cigar lighter/right hand fender console	20
12	Exterior 7-pin connector (2)	30
13	Right hand front post/right hand fender 3-pin auxiliary connectors (1)	30
14	Virtual terminal	5
15	Governor	25
16	Instrument cluster (2)	5
17	Horn	5
18	Battery power to headlight switch	10
19	Dome light/map light/radio (1)	10
20	Amber flashes	20
21	Tail lights	10

Weight bolt torque

1. After the first 30 minutes of operation and again each 10 hours of operation until the bolt torque stabilize, check the front weight and rear wheel weight bolts. Tighten all bolts to the specified torque in this manual.

Engine coolant level - deaeration tank



WARNING



Check and service cooling system according to maintenance instructions. Hot coolant can spray out if deaeration tank cap or radiator cap is removed while system is hot. **DO NOT Remove Radiator cap.** To remove deaeration tank cap, let system cool, turn to first notch, then wait until all pressure is released. Scalding can result from fast removal of the deaeration tank cap.

M513

IMPORTANT: The pressure cap on a pressure cooling system has a control valve that operates as a safety relief valve to keep the pressure within the system operating range. Operating the engine without a pressure cap or with a pressure cap that has a control valve that is not set to operate at the correct pressure can cause damage.

1. Checking the deaeration tank level:
 - A. After cooling system has cooled, turn cap to first notch and wait for all pressure to be released.
 - B. After all pressure is released, remove cap and check the coolant level in the deaeration tank. If level is below the neck of the tank, fill the tank with a mixture of **50 %** antifreeze and **50 %** water.
2. Inspect the pressure cooling system:
 - Check the seals at the deaeration tank pressure cap, hoses and hose connection.
 - Check for leaks: stop leaks of any size as soon as the leaks are found; a small leak can become a large flow when pressure is increased in the cooling system.
 - Check all hoses and hose connections with frequency.

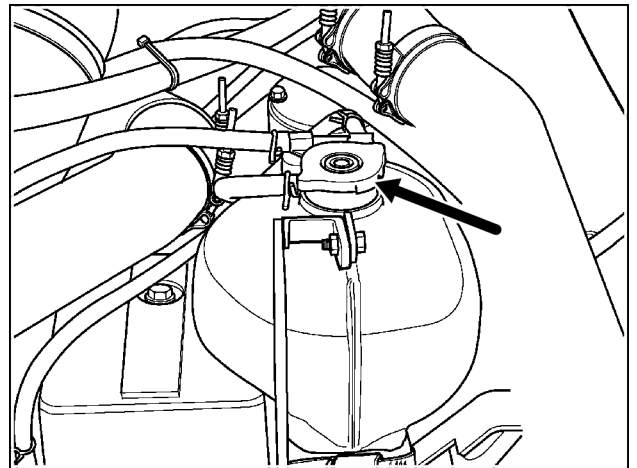

RCPH08CCH692AAC 1

16. Axle pivot pin (2 fittings).

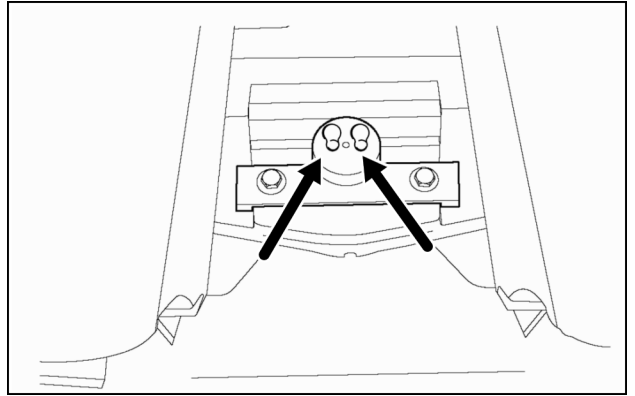

RCPH08CCH419AAB 16

Saddle suspended MFD axle

NOTE: Use **CASE AKCELA 251H EP MULTI-PURPOSE GREASE**

17. Axle pivot pin (2 fittings).

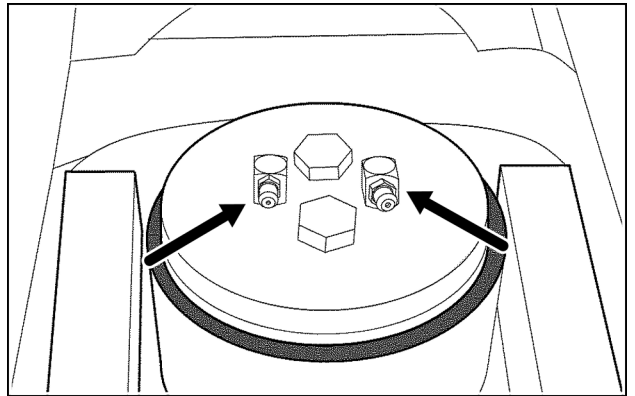

RCPH08CCH406AAB 17

18. Lift cylinder lower ball mount (1 each side).

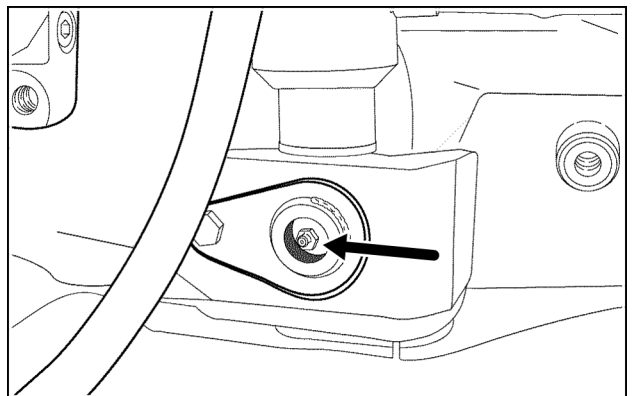

RCPH08CCH400AAB 18

19. Lift cylinder upper ball mount (1 each side).

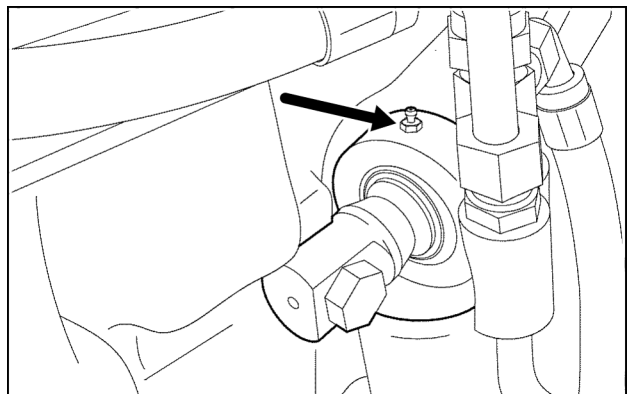

RCPH08CCH404AAB 19

Every 600 hours

Engine coolant antifreeze protection

1. Check the antifreeze protection level of the coolant system; it must exceed anticipated ambient operating temperatures.

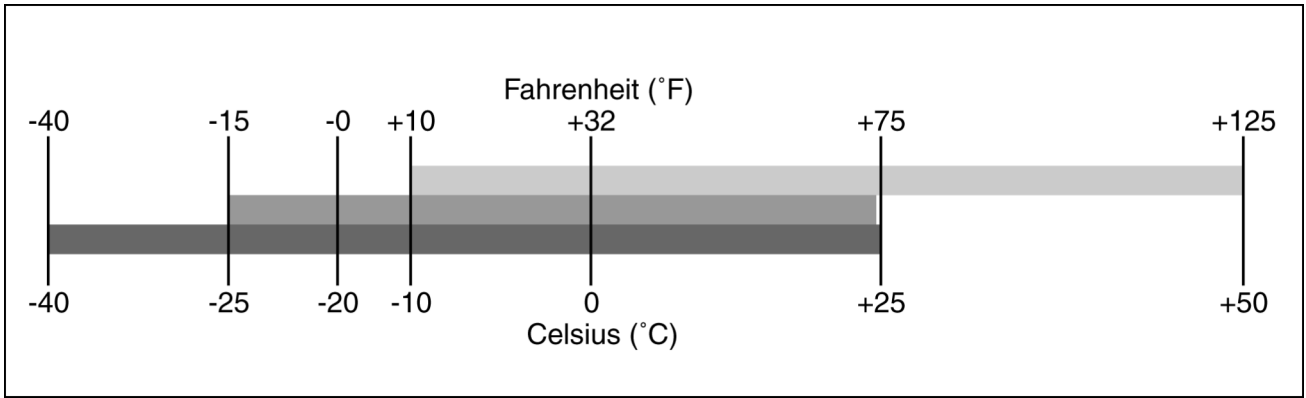

Axle oil viscosity/temperature usage recommendation

- CASE AKCELA 135H EP GEAR LUBE SAE 85W-140
- CASE AKCELA 135H EP GEAR LUBE SAE 80W-90
- CASE AKCELA GEAR LUBE SSL (75W-90)

Planetary oil change

NOTE: Change the oil after the first 10-50 hours of operation then use the regular change interval.

NOTE: If machine has been working hard in the field or roading, let it cool until the axle housing is warm to the touch.

3. To change the planetary oil, put the tractor on level ground. Turn the wheel hub until the oil level arrow (1) points down. Loosen the drain/fill plug (2), but do not remove it. Allow axle pressure to equalize with atmospheric pressure.

NOTE: Do not drain a cold planetary, oil should be warm, but not uncomfortable to the touch.

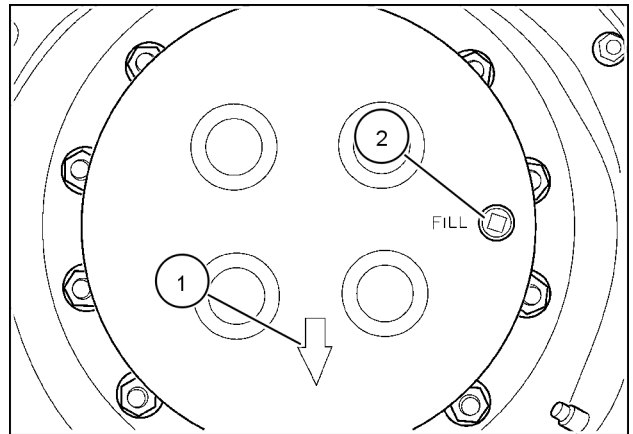

RCPH08CCH726AAC 10

4. Turn the wheel hub until the oil level arrow (1) is pointing horizontally to the left, and the plug is at the bottom of the hub. Slowly remove the drain plug (2). Clean the drain plug of any metal shavings that may have accumulated on the magnet.

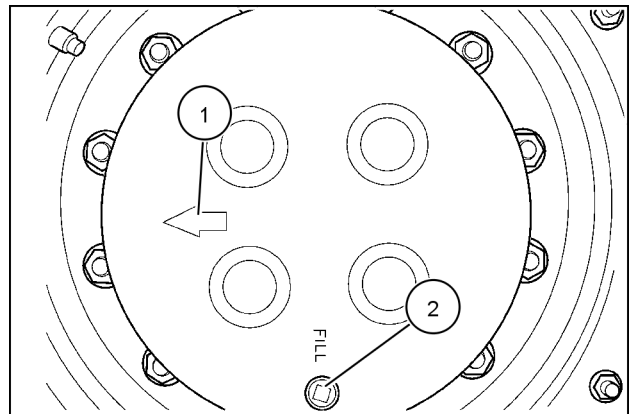

RCPH08CCH725AAC 11

Regulated transmission filter

NOTE: Change the oil filter at the recommended time interval or when indicated by the service monitor. Your dealer has approved filters. Do not use other type filters.

NOTE: Change the oil filter at the recommended time interval or when indicated by the service monitor. Your dealer has approved filters. Do not use other type filters.

IMPORTANT: If service monitor displays transmission filter restriction, replace both the regulated and main filters. To replace main filter, refer to page 7-74.

1. Use the following procedure to change the regulated filter:

- Remove the regulated filter (1) with a strap wrench or a 1/2-inch drive ratchet on the bottom of the filter. Turn counterclockwise to remove.
- Apply clean oil to the gasket on a new filter.
- Install the new filter. Turn filter clockwise until gasket makes contact with the filter head. Tighten filter another 1/3 turn.
- Start engine and check for leaks. Shut engine off.
- Check oil level in the transmission. Add **CASE AKCELA HY-TRAN ULTRA** as needed.

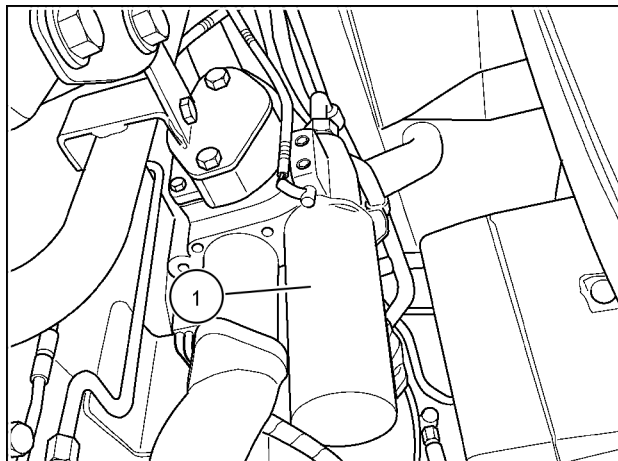

RCPH08CCH695AAC 1

IMPORTANT: Do not use a filter wrench to install the filter. Overtightening can cause damage to the gasket and filter.

Engine primary air filter

IMPORTANT: The primary air filter can be cleaned (with compressed air) a maximum of 4 times between filter changes. The secondary filter cannot be cleaned. Do not remove the secondary filter unless it is being replaced.

IMPORTANT: Do not wash either filter.

1. Open the tractor hood.

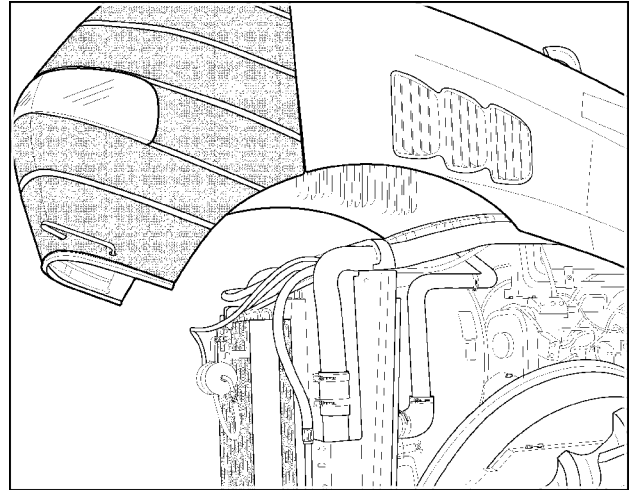

RCPH08CCH630AAC 1

2. Unsnap the four fasteners and remove the cover.

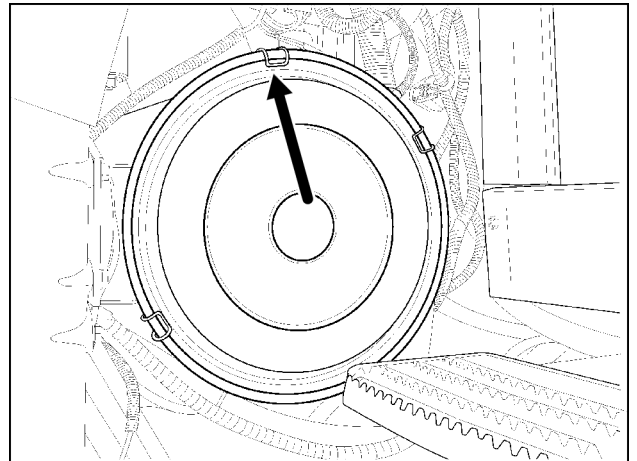

RCPH08CCH643AAC 2

3. Remove the primary filter by grasping on each side and pulling straight out

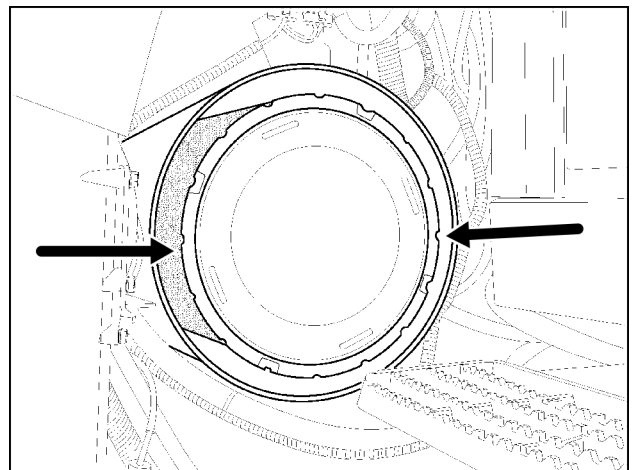

RCPH08CCH645AAC 3

3. Remove the frame (1) from the filter bowl. Remove the filter (2) and properly discard. Install a new filter, and reinstall the frame.

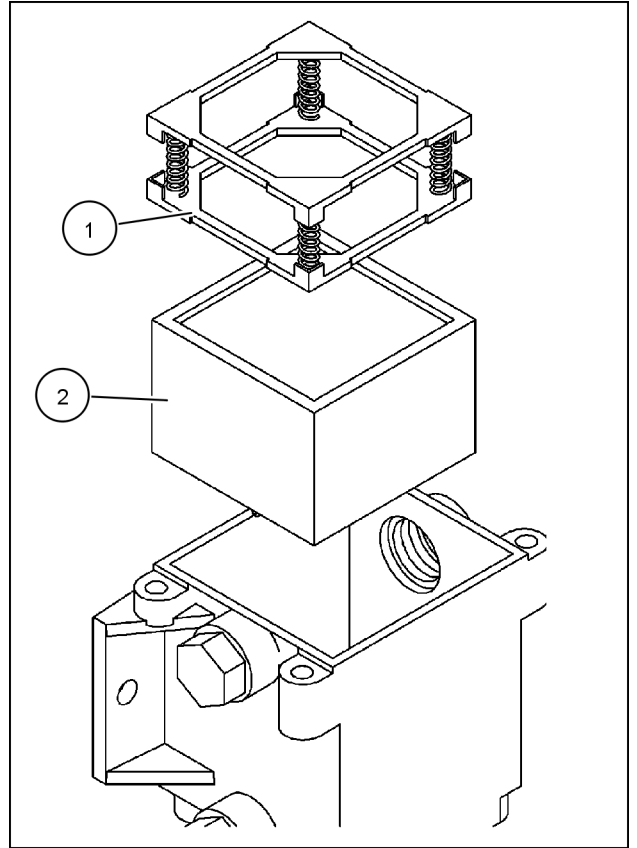

RCPH08CCH621BAC 3

4. Install the four wing bolts. Start the tractor and check for leaks. If the cover leaks, retighten the wing bolts. Do not over tighten. If leak continues, it may be necessary to replace seal in cover.

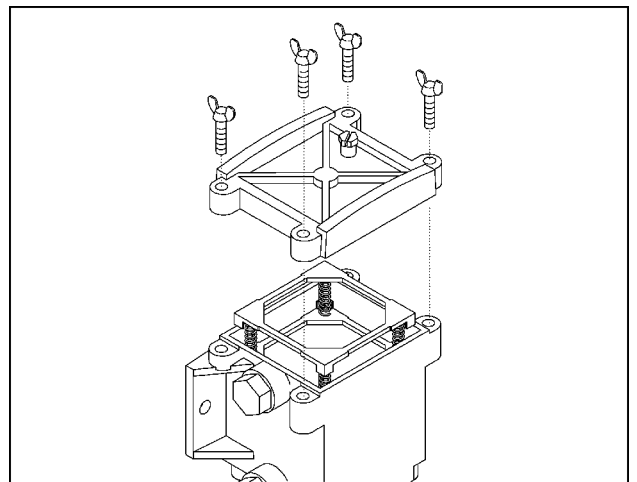

RCPH08CCH620AAC 4

7. Align the three tabs on the new bulb with the housing and install the bulb.

NOTE: Do not touch the glass bulb with bare hands.

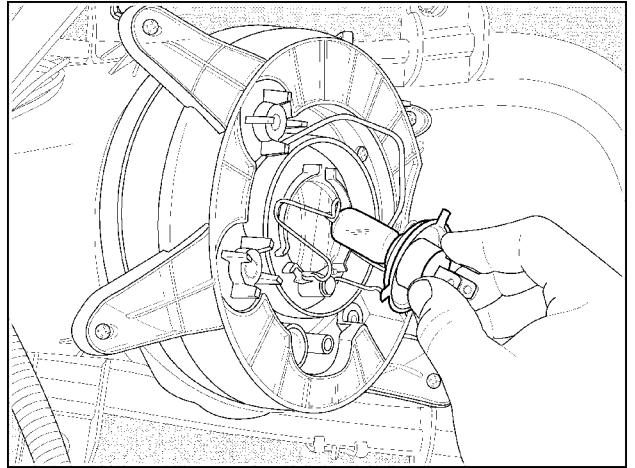

RCPH08CCH810AAC 7

8. Position the bulb retaining clip over the base of the bulb.

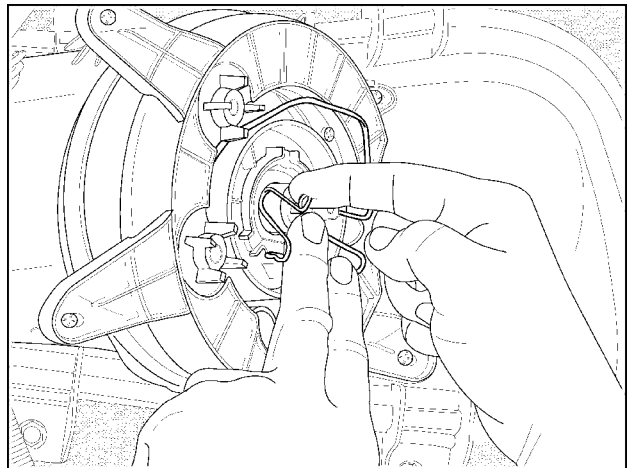

RCPH08CCH811AAC 8

9. Connect the bulb cover connector onto the bulb end.

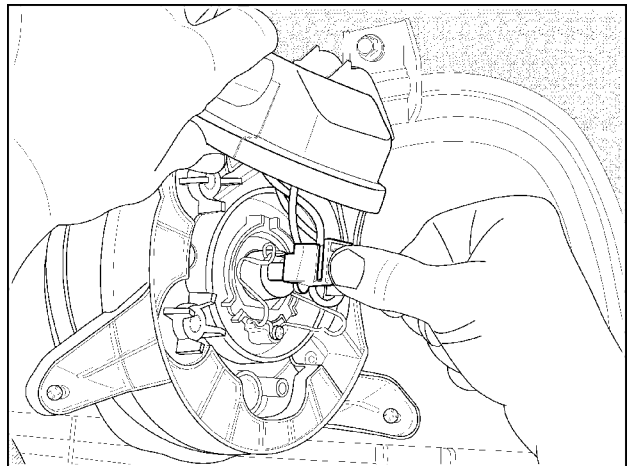

RCPH08CCH812AAC 9

9. Connect the harness to the lamp.

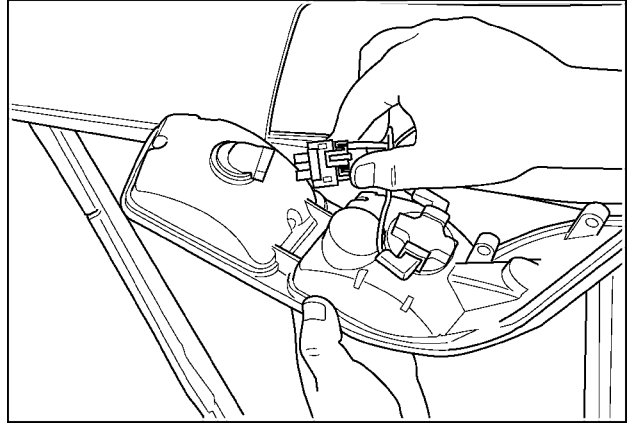

RCPH08CCH782AAC 7

10. Install the lamp assembly and secure with three retaining screws.

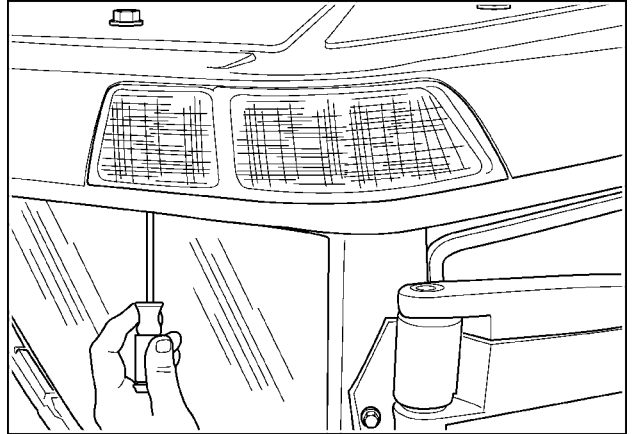

RCPH08CCH779AAC 8

8 - TROUBLESHOOTING

ALARM(S)

Display warnings

The programmable display notifies the operator when there is a problem with the engine, transmission, hydraulics or other operational systems that require corrective action. The warnings include an audible alarm, one or more indicator lights and a text message in the programmable display. The warnings are divided into 4 levels of importance and a descending order of priority within each level. In the case of multiple faults or warnings, the higher level or higher priority within a level will be the warning displayed.





Critical warning displays (Level 1)

Level 1 critical warnings require immediate attention, or there will be serious damage to the tractor. When a critical fault occurs, the red stop light, the amber warning light and the audible alarm flash continuously and a text message appears in the lower display. For very high engine coolant temp and very low engine oil pressure, the light near the gauge also flashes.

Shut down the engine immediately.

NOTE: On tractors with the performance instrumentation, the engine shuts down in 30 seconds after the fault is detected. The programmable display shows the 30 second count down timer.

IMPORTANT: Level 1 warnings cannot be turned off by pressing the "RESET" button. If the tractor must be moved, cycle the key switch to get an additional 30 seconds of running time to move the tractor. This can be done as many times as necessary to reach a desired location. However, damage to the tractor can occur.

Display	Fault description	Corrective action
 Engine intake air temp very high	Very high air to air temperature.	Shut the tractor engine Off immediately and check the heat exchanger for blockage.
 Engine oil pressure very low	Very low engine oil pressure.	Shut the tractor engine Off immediately and check oil level or other cause.
 Engine coolant temp very high	Very high engine coolant temperature.	Shut the tractor engine Off immediately and check coolant level or radiator for blockage or other cause.
 Transmission oil temp very high	Very high transmission oil temperature.	Shut the tractor engine Off immediately and check for blocked cooler or other cause.

TRAVELLING - Speeds

NOTE: Travel speeds are approximate at rated engine speed. No allowance is made for wheel slip.

Magnum 255

18 speed or 23 speed creep transmission

	Ground speed km/h			Ground speed mph		
	Group 48	Group 47	Group 46	Group 48	Group 47	Group 46
	710/70R42	480/80R46 18.4-R46	420/80R46 16.9-R46	710/70R42	480/80R46 18.4-R46	420/80R46 16.9-R46
	983	930	883	983	930	883
Creep 1	0.97	0.92	0.87	0.60	0.57	0.54
Creep 2	1.29	1.22	1.16	0.80	0.76	0.72
Creep 3	1.69	1.60	1.52	1.05	1.00	0.95
Creep 4	2.27	2.14	2.04	1.41	1.33	1.27
Creep 5	3.00	2.84	2.69	1.86	1.76	1.67
Forward 1	3.34	3.16	3.00	2.08	1.97	1.87
Forward 2	3.84	3.63	3.45	2.38	2.26	2.14
Forward 3	4.42	4.19	3.97	2.75	2.60	2.47
Forward 4	5.07	4.80	4.56	3.15	2.98	2.83
Forward 5	5.82	5.51	5.23	3.62	3.42	3.25
Forward 6	6.68	6.32	6.00	4.15	3.92	3.73
Forward 7	7.79	7.37	7.00	4.84	4.58	4.35
Forward 8	8.93	8.45	8.02	5.55	5.25	4.99
Forward 9	10.30	9.75	9.25	6.40	6.06	5.75
Forward 10	11.82	11.18	10.61	7.34	6.95	6.60
Forward 11	13.55	12.82	12.17	8.42	7.97	7.56
Forward 12	15.55	14.71	13.97	9.66	9.14	8.68
Forward 13	19.37	18.33	17.40	12.04	11.39	10.81
Forward 14	22.22	21.02	19.96	13.81	13.06	12.40
Forward 15	25.62	24.24	23.02	15.92	15.06	14.30
Forward 16	29.39	27.81	26.40	18.26	17.28	16.41
Forward 17	33.72	31.90	30.29	20.95	19.82	18.82
Forward 18	38.67	36.59	34.74	24.03	22.73	21.59
Creep Rev 1	1.40	1.33	1.26	0.87	0.82	0.78
Creep Rev 2	3.26	3.09	2.93	2.03	1.92	1.82
Reverse 1	4.81	4.55	4.32	2.99	2.83	2.69
Reverse 2	5.52	5.22	4.96	3.43	3.25	3.08
Reverse 3	11.21	10.61	10.07	6.97	6.59	6.26
Reverse 4	12.86	12.17	11.55	7.99	7.56	7.18

**1930 mm (76 Inch) Narrow
2030 mm (80 Inch) Wide**

Install the mounting bracket (1) in the last set of holes with the support mounting brace mounting surface (2) facing the tire. Install the fender support brace (3) on the tractor side of the mounting brace.

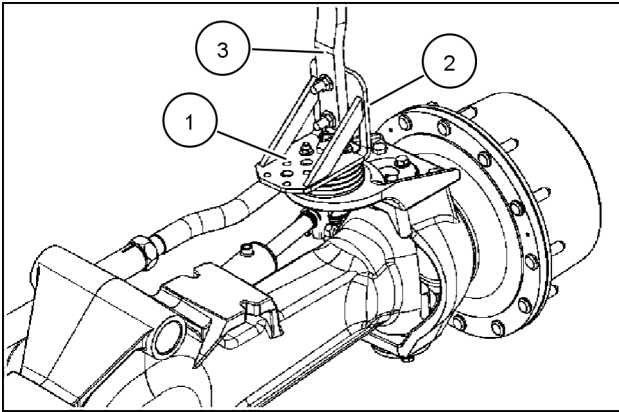

RCPH08CCH478AAC 12

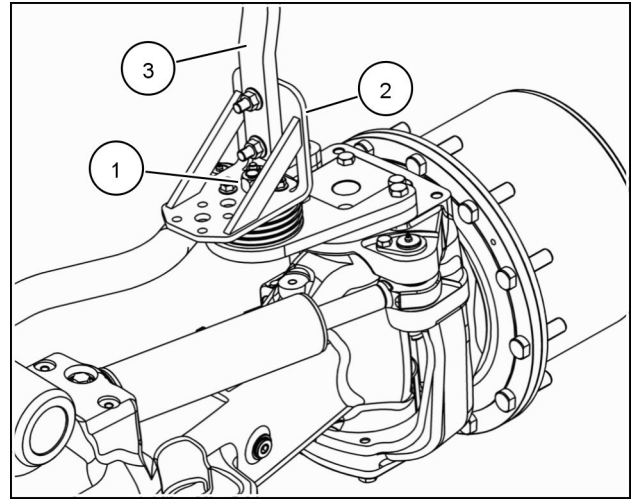

RCIL08CCH004BAB 13

Standard and suspended

Class V MFD and suspended MFD

**2030 mm (80 Inch) Narrow
2135 mm (84 Inch) Wide**

Install the mounting bracket (1) in the middle set of holes with the support mounting brace mounting surface (2) facing the tire. Install the fender support brace (3) on the tractor side of the mounting brace.

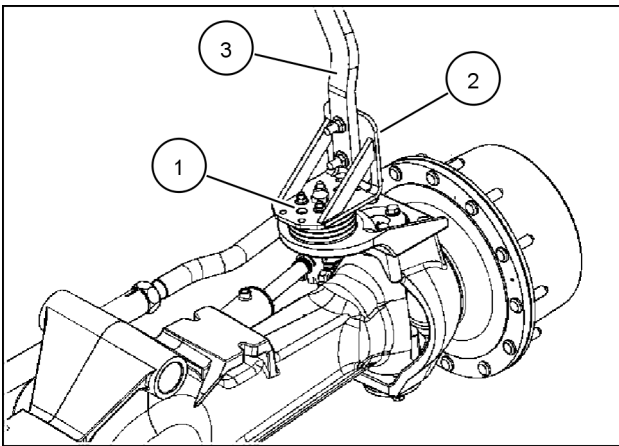

RCPH08CCH479AAC 14

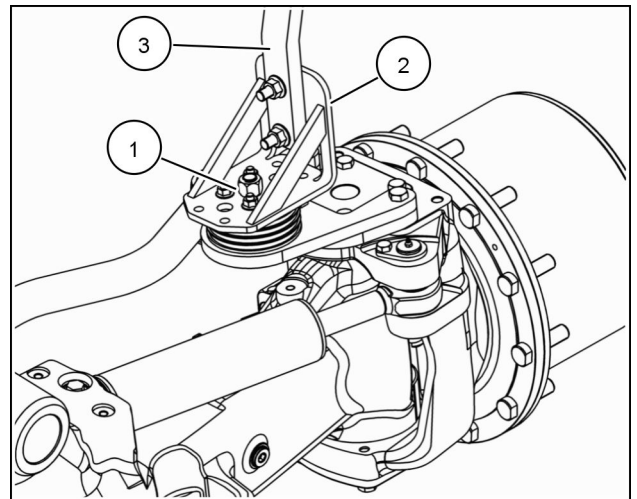

RCIL08CCH005BAB 15

Standard and suspended

Class V MFD and suspended MFD

Three pneumatic connections are located at the tractor rear: feed line (1), reservoir line (2) and brake line (3).

A maximum of 2.5 times the tractor weight can be towed if this pneumatic trailer brake system is used.

NOTE: Water should be removed from the air reservoir daily at the drain valve.

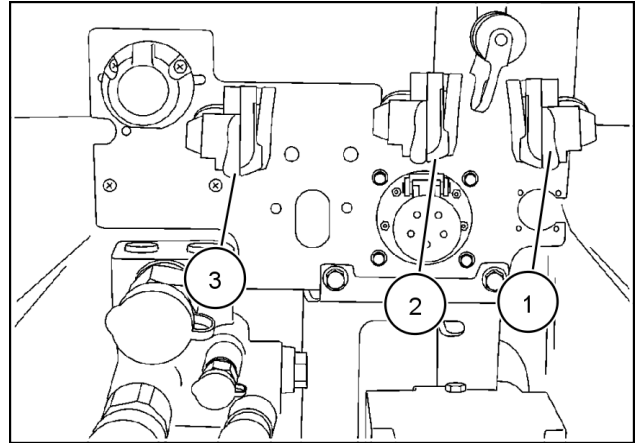

RCPH08CCH465AAC 3



WARNING



Make sure the system is at working pressure before operating the brakes fitted with a trailer. Failure to do this can result in injury or death.

M534



WARNING



DO NOT park an unattended tractor/trailer combination using air pressure to apply the brakes (Dual Line Pneumatic Braking System). The mechanical park brakes on both tractor and trailer(s) MUST be applied.

M689



WARNING



Brake pedals must be locked together for road travel. This will insure uniform brake application and maximum stopping ability. Failure to comply could result in death or serious injury.

R112A



WARNING



Extra weight and bad traction conditions such as mud or ice increase your stopping distance. Remember that liquid in the tires, weights on the machine or wheels, tanks filled with fertilizer, herbicides or insecticides -all these add weight and increase the distance you need in which to stop.

M113B



WARNING



For speeds up to 16 km/h (10 MPH), make sure that the weight of a trailed vehicle that is not equipped with brakes does NOT EXCEED 1.5 times the Tractor weight. For speeds up to 40km/h (25 MPH), make sure that the weight of the trailed vehicle that is not equipped with brakes, does NOT EXCEED the weight of the Tractor. Stopping distance increases with increasing speed as the weight of the towed load increases, especially on hills and slopes.

M814A

CLICK HERE TO **DOWNLOAD** THE COMPLETE MANUAL

- Thank you very much for reading the preview of the manual.
- You can download the complete manual from: www.heydownloads.com by clicking the link below



- Please note: If there is no response to CLICKING the link, please download this PDF first and then click on it.

CLICK HERE TO **DOWNLOAD** THE COMPLETE MANUAL