

ORIGINAL INSTRUCTIONS

CX350C-8
CX380C-8
Crawler Excavator

OPERATOR'S MANUAL

Part number 51508167
1st edition English
July 2018



CLICK HERE TO **DOWNLOAD** THE COMPLETE MANUAL

- Thank you very much for reading the preview of the manual.
- You can download the complete manual from: www.heydownloads.com by clicking the link below



- Please note: If there is no response to CLICKING the link, please download this PDF first and then click on it.

CLICK HERE TO **DOWNLOAD** THE COMPLETE MANUAL

Product identification

The CX350C-8 — CX380C-8 is a crawler hydraulic excavator. It consists of an undercarriage fitted with tracks and a turntable bearing which supports the upperstructure frame. The upperstructure frame supports the attachment, at the front end of the machine, plus the engine, hydraulics and cab. When the operator works the controls, the engine-driven pump delivers hydraulic fluid to the control valves. The control valves distribute the hydraulic fluid to the various cylinders and hydraulic motors employed. A cooling system maintains the hydraulic fluid at normal operating temperature.

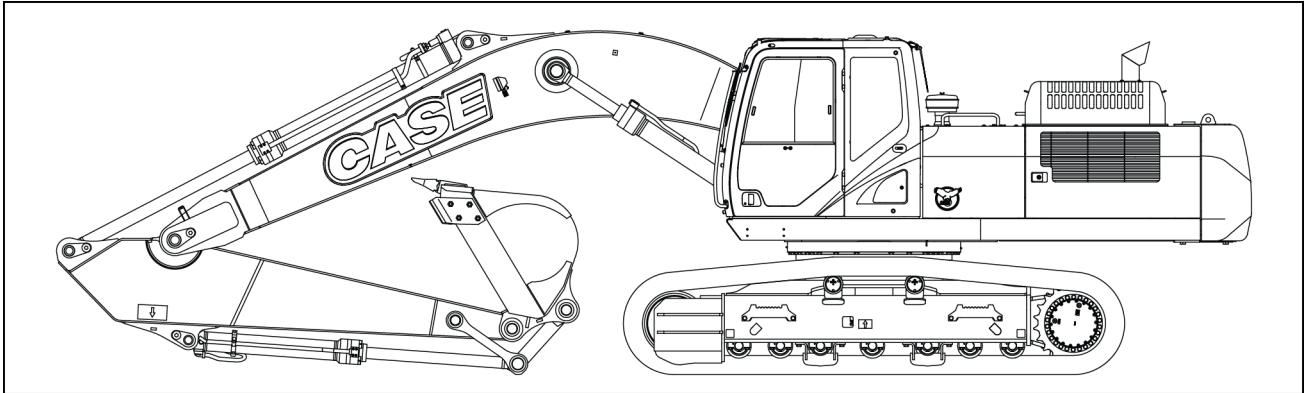

SMIL18CEX0787EA 1

CX350C-8 — CX380C-8

When ordering parts, obtaining information or assistance, always supply your CASE CONSTRUCTION Dealer with the type and serial number of your machine or accessories. Write the following in the spaces below: the type, serial number and year of manufacture of your machine, accessories and the serial numbers of the various hydraulic and mechanical components.

Machine

(1) Type/Model

Hydraulic Excavator CX350C-8 — CX380C-8

(2) Product Identification Number (PIN)



SMIL18CEX0806AA 2

- When alighting from or getting into the operator's compartment, always face the machine and use the steps and access handles.
- Be sure you know the position and function of each control. Incorrect operation of the controls can cause serious injuries.
- Check all controls and safety devices in a safe, open area before starting work.
- Keep away from dangerous areas such as ditches, overhangs, rocky areas, etc. Make a survey of the work-site and determine the possible dangers before using the machine.
- Before parking the machine, make sure that the ground is stable. Plan the worksite so that the ground is flat, hard and level.
- Before moving the machine to work in a new area, walk around to determine all possible causes of accidents there. Holes, obstacles, debris and other danger risks in the working area can cause serious injury.
- Be ready to meet emergencies. Always carry a first aid kit and if possible, fire extinguisher (not supplied) within easy reach on board. Make sure the fire extinguisher is regularly serviced in conformance with the manufacturer's instructions.
- Check the fastening of the main components: counterweight, turntable bearing and operator's compartment. In the event of problems, consult your CASE CONSTRUCTION Dealer.
- Make sure you understand the symbols used on the machine safety decals. Keep the decals clean so that they are perfectly legible at all times.
- Work out a means of convenient escape from the machine (emergency exit via the windshield or the rear window glass) in the event of the machine turning over or tipping over or the cab door being jammed.
- Make sure you are perfectly familiar with traffic regulations and special safety equipment requirements before transporting this machine on a public highway.
- When loading trucks, never swing the load over the truck cab.
- Before undertaking any travel on the job site, make sure the itinerary to be followed is completely safe. If bridges are to be crossed, make sure they are perfectly capable of supporting the weight of the machine.
- Always steer round large obstacles such as boulders, big trees, etc.

Quick coupler (optional)

- Every day, check that the locking bar functions correctly and that it is not fouled by foreign matter. Clean the locking system if necessary.
- If you are obliged to use the quick coupler with buckets not manufactured by CASE CONSTRUCTION, make sure the diameter of the pins and the width between the bucket lugs meet the dimensions needed to fit the quick coupler (pins, washers, bushings, etc.). Consult your CASE CONSTRUCTION Dealer.

Operating the machine

- When working on a public highway, use standard traffic signs and take into consideration the working range of the upperstructure and its attachments. Local or national regulations stipulate the number, type and location of reflector strips.
- Avoid running the engine in a confined space. If there is no alternative, proper ventilation must be provided at all times.
- Do not allow anyone else on the machine. The passenger could fall or cause an accident.
- Never operate the working or travel controls unless you are properly seated in the operator's seat with the seat belt correctly fastened.
- Before starting the engine, check the direction of travel (in forward drive, the reduction gears should be to the rear of the machine).
- Do not work near overhead high-voltage electric lines without checking beforehand that all necessary measures have been taken to respect the minimum distances:
Less than 57000 volts: **3 m (9.8 ft)**.
More than 57000 volts: **5 m (16.4 ft)**.
- Study the position of any existing pipelines or conduits before starting work. Electrical cables, gas and water pipes and other underground installations can cause serious injury.
- Always make allowance for working conditions (sloping or rough ground), the site and weather conditions when driving the machine.
- Do not allow anyone to stand in the machine working area. Accidental operation of the upperstructure swing control or of an attachment control could cause an accident. Stop all operations until everyone has moved away.
- Before operating the dozer blade (if equipped) make sure that there is no one in the working area of the latter.
- Operate all controls gradually to ensure smooth machine operation.
- Whenever load handling operations are to be carried out, it is imperative to adhere strictly to the instructions given in this manual and local legislation.
- It is forbidden to use the machine to carry out tasks other than those for which it is intended. Never use the equipment for sweeping the ground to level out rubble or push objects (transversal stress on the attachment).
- Stop the engine and remove the ignition key when the machine is not in use, even for short periods of time.

Decal positions

When replacing a decal, make sure it is located as shown below.

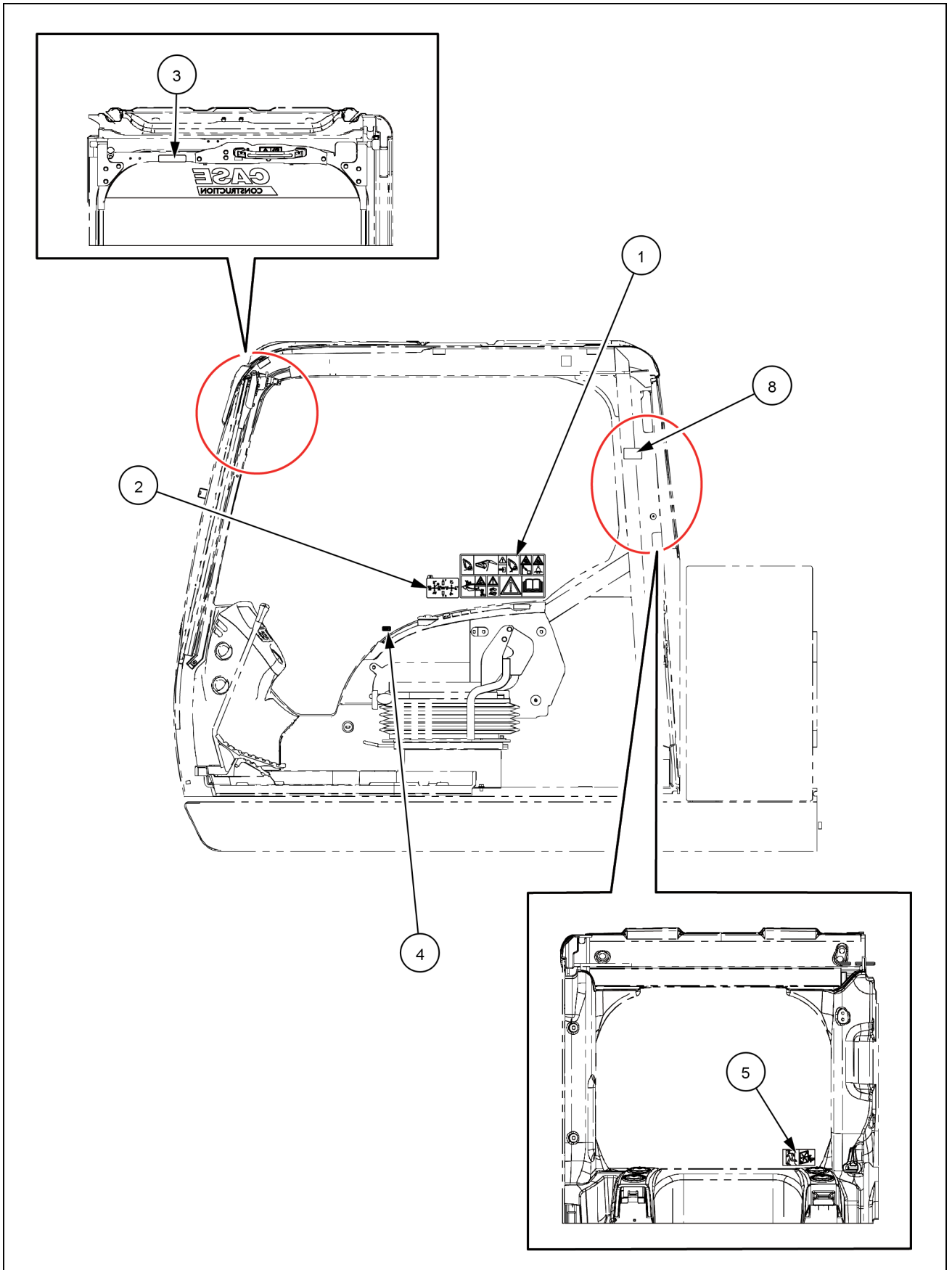

(25) Common rail high pressure decal

Part number: KHP13170

Common rail injection system contains fuel under extreme pressure that can cause fatal injuries. Do not open the common rail pump, or loosen the common rail high pressure lines, or touch any other component of the common rail injection system. Consult the CASE CONSTRUCTION dealer for service.

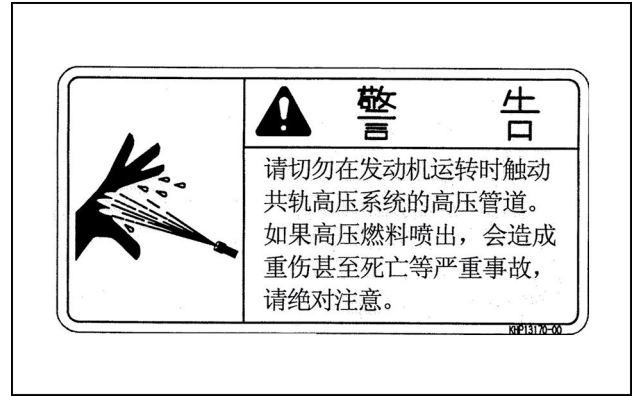

KHP13170 34

(26) Engine operation

Part number: KHP22400

Always stop and cool down the engine before making any maintenance operation in the engine compartment.

Do not step on the engine as this can cause serious damages to the engine components and serious injuries to the operator.

Make sure to read operator's manual to understand proper procedures for the engine maintenance.



KHP22400 35

(27) Fuel Line Valve

Part number: KHP29601

Thoroughly read and understand the operator's manual before starting inspection and service of the fuel system.

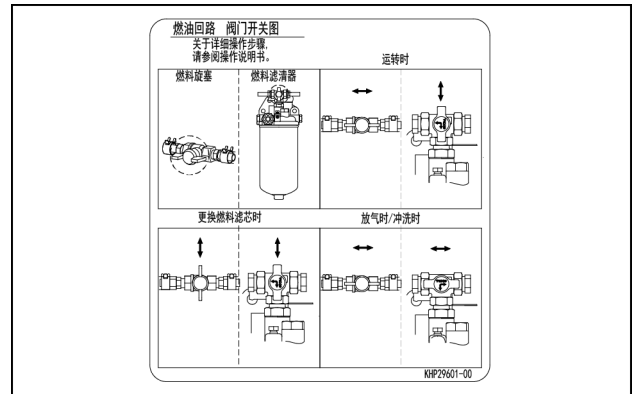

KHP29601 36

(28) Starting the engine

Part number: KHP1336

Do not try to start the engine by auxiliary tools. Machine may start to move suddenly and unintendedly causing serious injuries to the operator and to the bystanders.

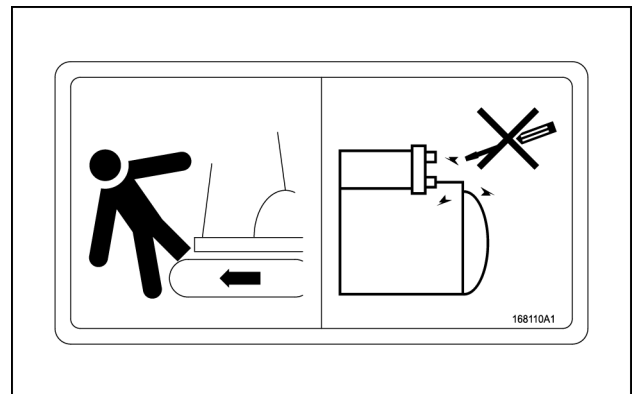

KHP1336 37

Right-hand control lever:

- 5. The boom lowers.
- 6. The boom raises.
- 7. The bucket retracts (filling).
- 8. The bucket extends (dumping).

NOTE: The speed of movement of the boom or the bucket depends on the control lever tilt angle. In the intermediate position two movements can be obtained simultaneously.

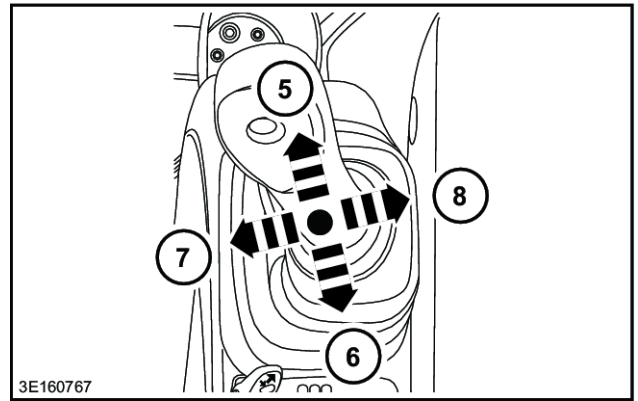

3E160767

3E160767 3

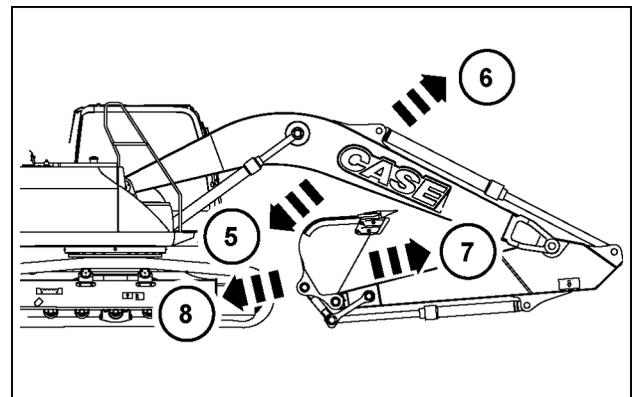

SMIL16CEX1595AB 4

Cab internal lighting

The room lamp allows to have internal lighting near to the operator's station. The room lamp has a control switch with three operating positions:

- OFF
- DOOR
- ON

When the switch is set in DOOR position, the room lamp turns on automatically when the door is opened, and turns off automatically when the door is closed.

NOTE: If the door is left open for more than 30 s, the lamp is forcedly turned off in order to prevent drain of the battery charge.

The ON position of the switch allows to turn on the room lamp only if the starter key is set in ACC or ON position.

NOTICE: Never leave the room lamp switch in ON position. The battery charge may be drained out. As the need for lighting ends, set the switch to OFF or DOOR position.

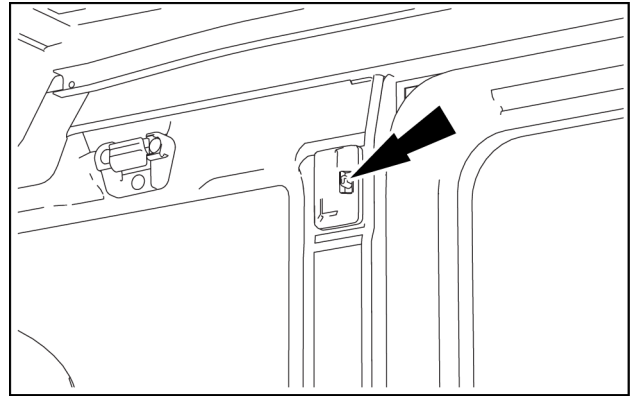

SMIL14CEX2568AA 1

Emergency exit hammer

Located on the left-hand cab, use the hammer (1) to break the rear window, and then push the window strongly and escape outside.

Consult your CASE CONSTRUCTION dealer for window installation.

NOTICE: Do not break the rear window except when it is absolutely necessary, such as to escape in an emergency.

NOTICE: Do not place anything in front of the window. Doing so may obstruct an emergency escape.

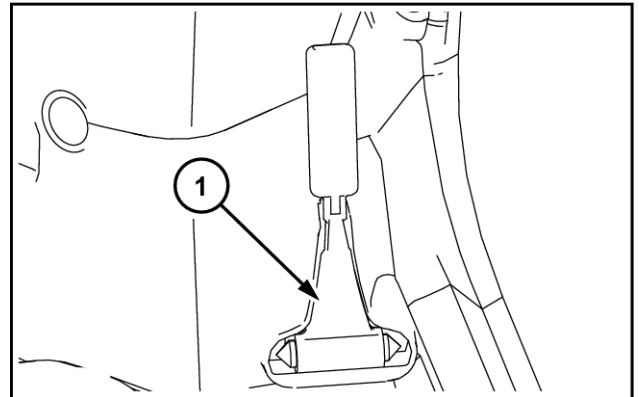

SMIL13CEX2621AB 1

Sliding windows on door

The two windows on the cab door can be opened singularly or simultaneously. Release the lock and slide each window in order to open it.

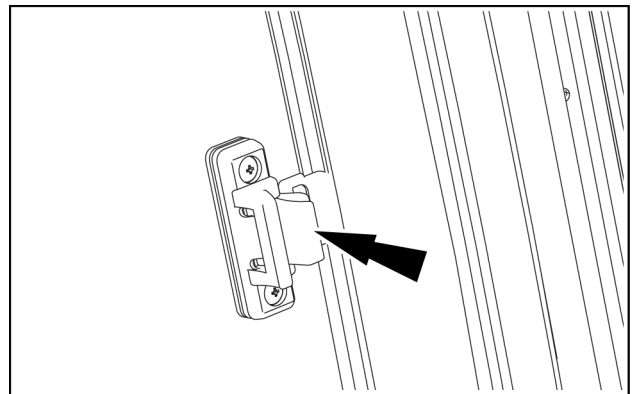

SMIL14CEX2569AA 1

Control buttons

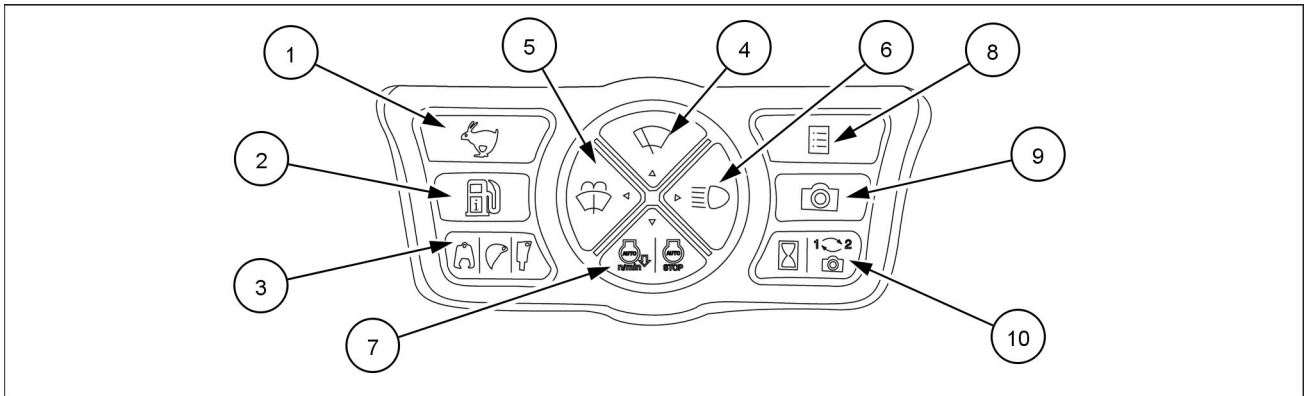

SMIL18CEX0535EB 6

1. Travel mode select button

The selection toggles between slow speed mode ("Turtle") and fast speed mode ("Rabbit") every time the travel mode selector switch is pressed.

NOTICE: perform all changes to the travel mode while the machine is stopped.

Use the "Turtle" mode to travel on slope, off-road or soft ground.

Use the "Rabbit" mode to travel on a hard, flat, maintained road.

NOTE: the slow speed mode is automatically selected when the engine is started.

NOTE: if the fast speed mode is selected on the machine, it automatically switches to slow speed mode when the load increases on uphill road, and automatically returns to fast speed mode as the load decreases.

2. Fuel consumption indicator button

Push to show alternately on the display the cumulative average fuel consumption or the cumulative fuel consumption amount.

- Cumulative average fuel consumption: displayed in L/hr.

- Cumulative fuel consumption: displayed in L.

Push the fuel consumption indicator button for 3 seconds to reset the cumulative average fuel consumption and cumulative fuel consumption amount.

3. Attachment selection button

When using a hydraulic attachment, press the button to set the auxiliary hydraulic circuit to the pattern that properly matches the type of attachment used.

Set the breaker mode for using a single acting hydraulic attachment such as hydraulic breaker. The breaker icon appears on the display.

Set the crusher mode for using a double acting hydraulic attachment such as hydraulic crusher. The crusher icon appears on the display.

NOTICE: before changing the setting of the auxiliary hydraulic circuit, stop operation and set the machine in parking position.

4. Wiper button

The button sets three operating conditions: "Off", "Intermittent" and "Continuous".

When the button is pressed to operate the wiper intermittently, (I) is displayed on the monitor.

When the button is pressed again to operate the wiper continuously, (II) is displayed on the monitor.

When the button is pressed again to stop the wiper, "Off" is displayed on the monitor.

NOTICE: Do not operate the wiper when the front glass is dry. Doing so could damage the wiper.

5. Windshield washer button

Press and hold the windshield washer button to activate the wiper and the washer to clean the windshield. Release the button to stop the cleaning operation.

NOTICE: Do not operate the washer when the reservoir is empty. Doing so could damage the electric pump.

6. Working lights button

Press the working lights button to turn on the working lights on the front of the machine.

Press the button again to turn the working lights off.

7. Idle mode button

Press the button to select the automatic control mode of engine idling or stopping.

If auto idle mode is selected, the engine speed drops automatically to low idle if any lever or pedal is not operated for **5 s**. The auto idle icon appears on the display. To restore the engine speed, operate any control lever, or turn the engine speed throttle.

If auto stop mode is selected, the message IDLE SHUT DOWN is displayed, an alarm sounds, and the engine stops automatically **10 s** thereafter if the engine speed is kept at **1200 RPM** or below and the gate lock lever is kept in lock position for **3 min**. The auto stop icon appears on the display

If the sequence of auto idle and auto stop is selected, auto idle activates as described before, and if the gate lock lever is also set to the lock position, idle shutdown eventually activates after **3 min**. The combined icon appears on the display.

NOTE: To restart the engine, turn the starter key to OFF position and then start the engine.





2. With the band button, select either "AM" or "FM".
3. Select a station with preset buttons or the seek button.
4. Adjust the volume with the volume adjustment buttons.
5. To switch "OFF" the radio, hold down the power button for a few seconds.

Adjust the volume for the connected portable audio device to be the same as for the radio.



The volume also can be adjusted with the volume buttons on the unit.

Do not use a connection cord with the wrong size or wrong shape jack.

Manual tuning

To change the frequency manually, hold down the  or  button for a few seconds, then press the  or  button again within 2 seconds.

Automatic Tuning (Seek)

When the  or  button is pressed, the radio begins to search automatically for receivable stations and stops at the frequency where it finds a station.

Presetting Stations

1. Press the band button to select either "AM" or "FM", then press the seek button to select a station.
2. Hold down the desired preset button for a few seconds to preset a station.
3. Repeat Steps 1 and 2 to preset other stations.
If you hold down the button that already has a station preset to it for a few seconds, the new station is preset replacing the old one.

Auto preset

While you are playing the radio, if you hold down the auto preset button for a few seconds, the radio searches automatically for receivable stations in that band and registers them to preset buttons (1) through (6).

NOTE: If you use the auto preset function, the presets for any stations registered before are erased. If a station is not registered in the button you want, register it with the preset function.

External input

During radio reception, you can connect a commercially-available audio portable unit and listen to music, etc.

Connect from the headphone terminal of your portable audio device using a commercially available cord (without resistance).

Use any commercially-available stereo mini-plug cord (D3.5) for external input (AUX).

Pressing the external input switch button again returns input to the radio.

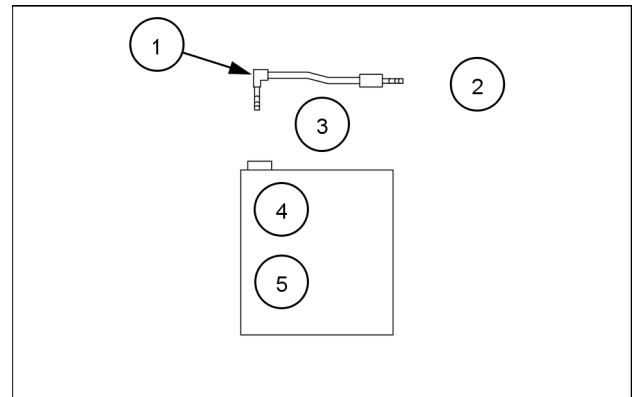

SMIL18CEX0537AB 2

1	Stereo mini plug
2	Radio AUX IN
3	Check the shape.
4	Headphone terminal
5	Portable audio device

MP3 Player

During radio reception, you can connect a commercially-available audio unit or flash memory to listen to music, etc.

Connect from the headphone terminal of your portable audio device using a commerciallyavailable cord (without resistance).

Use any commercially-available USB cable for external input (USB).

Pressing the external input switch button again returns input to the radio.

Adjust the volume for the connected portable audio device to be the same as for the radio.

Adjust the volume for the connected portable audio device to be the same as for the radio.

The volume also can be adjusted with the volume buttons on the unit.

Do not use a connection cord with the wrong size or wrong shape jack.

Lower panels

⚠ WARNING

Moving parts!
Make sure the lower panels are properly closed before driving the machine.
Failure to comply could result in death or serious injury.

W0910A

Located under the upperstructure frame, these panels provide access to certain machine components.

NOTICE: Do not run the machine with the panels removed.

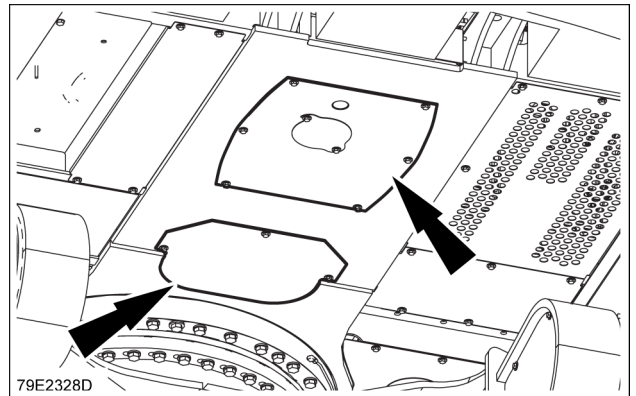

79E2328D 1

Windshield washer reservoir

The windshield washer reservoir is located inside one of the left-hand compartments behind the cab.

Make sure to check the reservoir level each day in order not to let the windshield washing fluid run out completely.

NOTICE: Never operate the windshield washer when the reservoir is empty. This will cause damage to the electric pump.

NOTE: In cold weather, add anti-freeze to the windshield washing fluid.

NOTE: The reservoir can be lifted out of its support in order to ease the maintenance operations.

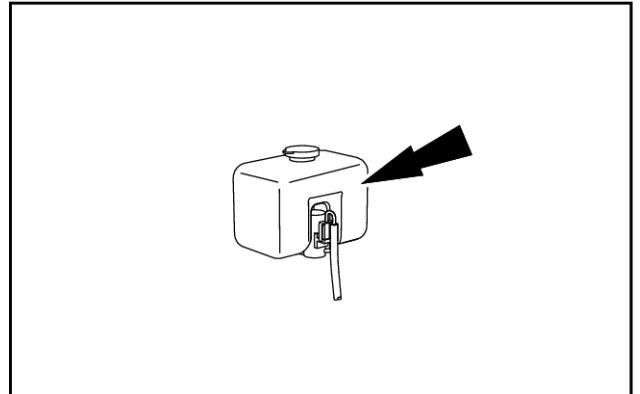

SMIL13CEX2650AB 1

Bringing the machine up to operating temperature

Before starting operation, the main systems of the machine shall be warmed up to their normal operating temperature.

NOTE: The normal operating temperature for the hydraulic fluid is 50 – 80 °C (122 – 176 °F) . This corresponds to four segments lit on the hydraulic temperature gauge.

NOTE: The normal operating temperature for the engine coolant is 75 – 90 °C (167 – 194 °F). This corresponds to four segments lit on the coolant temperature gauge.

A warm-up procedure shall thus be carried out in order to grant a proper and safe usage of the machine, and in order to grant the best machine performance and fuel efficiency.

NOTICE: The warm-up of the machine is mandatory when operating in severe winter climates.

NOTICE: The warm-up of the machine prevents wear and severe damages to the engine, to the fuel system and to the hydraulic system.

NOTICE: The exhaust pipe becomes extremely hot while the engine is idling. Make sure that there is no flammable material such as plants, dried grass, paper waste, oil and old tires close to the exhaust pipe before starting warm-up procedure.

NOTICE: Never cover the grids of the radiators with flammable materials.

Automatic machine warm up

Regardless of the ambient conditions, the machine control system allows to carry out an automatic warm-up procedure that brings the temperature of the main operating fluids to the proper level for machine operation.

Start the engine with the speed throttle in the low idle position and let the machine complete the automatic warm-up procedure. During the automatic warm-up, the engine speed and the engine load are automatically managed in order to match the warm-up cycle to the ambient conditions and to optimize the warm-up cycle in respect to the machine operating parameters.

NOTE: the engine speed and the noise of the hydraulics are supposed to change during the warm-up cycle.

NOTICE: The automatic warm-up procedure is the recommended operating practice. However, the automatic warm-up procedure can be overridden either by changing the engine speed manually or by operating any operation lever.

As the procedure starts up, the message AUTO WARM UP is displayed:



The automatic warm-up procedure takes about **5 – 10 min** depending on the ambient conditions.

After completion of the automatic warm-up procedure, the AUTO WARM UP message disappears, and the engine speed gets back to low idle.

Stopping the unit

Stopping the engine

1. Lower the attachment until it is resting on the ground.
2. Turn the engine throttle (1) to low idle position.
3. Let the engine run for about **5 min.**

NOTICE: If the engine is stopped suddenly, the lubricated section on the turbocharger gets dried from the high heat, leading to a turbocharger failure.

4. Turn the starter key (2) to OFF position.

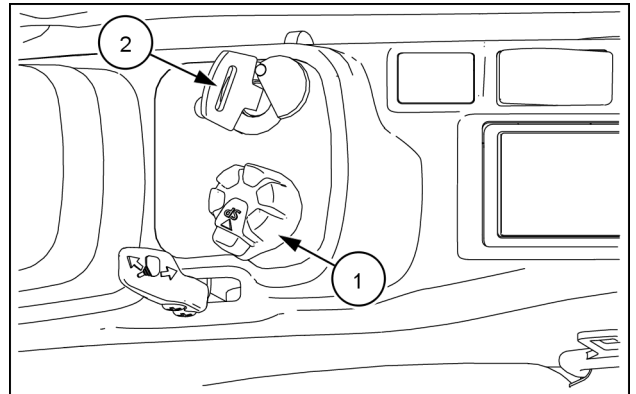

SMIL15CEXY892AB 1

Emergency stop switch

In the event of an emergency or if it is not possible to stop the engine using the starter key, press the emergency stop switch on the left-hand console.

NOTE: This switch should only be used in case of an emergency. Do not use it on a day-to-day basis to stop the engine.

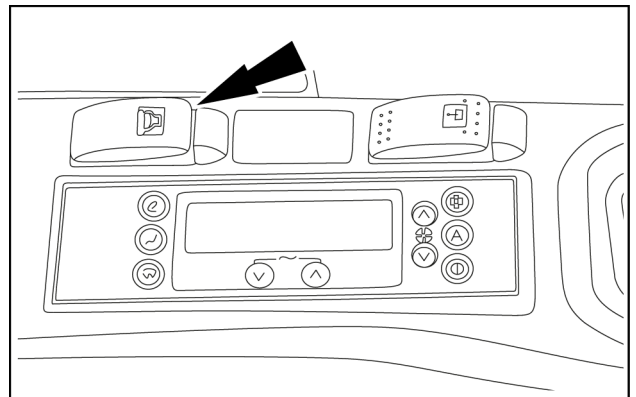

SMIL14CEX2520AA 2

CLICK HERE TO **DOWNLOAD** THE COMPLETE MANUAL

- Thank you very much for reading the preview of the manual.
- You can download the complete manual from: www.heydownloads.com by clicking the link below



- Please note: If there is no response to CLICKING the link, please download this PDF first and then click on it.

CLICK HERE TO **DOWNLOAD** THE COMPLETE MANUAL

Loading the machine on a rear loading type trailer (without front equipment installed)

⚠ WARNING

Tip-over hazard!

The counterweight **MUST** be removed before transporting the machine without an attachment. Consult your dealer.

Failure to comply could result in death or serious injury.

W0260A

⚠ WARNING

Pressurized system!

Before removing the attachment from the machine, make sure the air pressure and hydraulic oil pressure are at zero.

Failure to comply could result in death or serious injury.

W0284A

If the machine has to be transported without the complete front equipment (boom and arm), the counterweight shall be removed from the base machine. Loading the base machine on the trailer with the counterweight installed affects the stability of the base machine itself, and definitely compromises its climbing ability.

NOTICE: *the use of lifting systems is necessary for removal and installation of the machine front attachment and of the counterweight. Refer to your CASE CONSTRUCTION dealer for proper removal and installation procedure.*

Select the H work mode.

Align the machine to the trailer, so as the travel motors face the trailer ramps.

NOTICE: *In this position, traveling and steering control become opposite to each other.*

Slowly climb the trailer ramps. Slowly travel on the trailer bed to reach the resting position.

Slowly turn the upper structure **180°**.

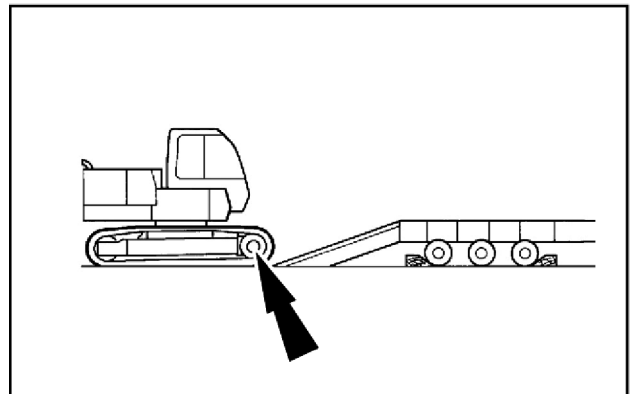

SMIL13CEX2721AB 5

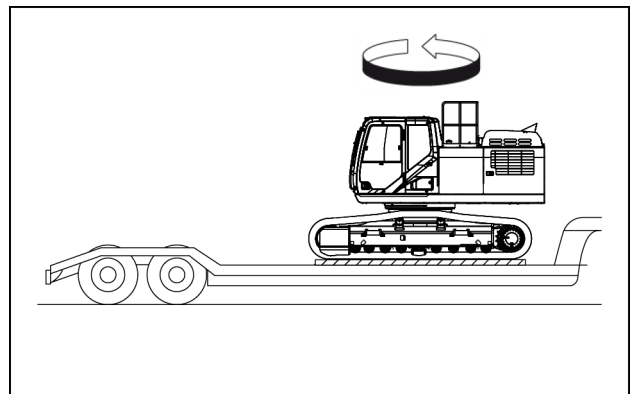

SMIL15CEXZZ46AA 6

- Check the cylinders are not leaking oil.
- Check the condition of all lines.
- Check the condition of the bucket and its tools.

After starting the engine

- Did the engine start correctly? Are the exhaust fumes normal? Any strange noises?
- Check for abnormal noise on the hydraulic components.
- Check the components for signs of leaking oil or water.
- Check the audible alarm devices, working lights and windshield wipers.
- Check that all circuits (travel, swing and tool) are functioning correctly.

NOTICE: *if the slightest defect is found, repair it immediately before using the machine or consult your CASE CONSTRUCTION Dealer.*

Maintenance planning

Maintenance chart

Maintenance action	Change fluid				Drain fluid				Page no.
	Grease	Replace	Check	Adjust	Clean	Adjust	Clean	Adjust	
		Check							
		Replace							
Break-in period									
Grease points (Bucket)	x								6-15
Cab protection system		x							6-15
Tightening torques		x							6-15
Track shoe bolt torque		x							6-15
Hydraulic oil return filter			x						6-15
Pilot line filter			x						6-15
Swing reduction unit oil				x					6-15
Travel reduction units oil				x					6-15
Every 10 hours									
Engine oil level		x							6-16
Engine coolant level		x							6-17
Hydraulic oil level		x							6-18
Fuel tank drain					x				6-19
Fuel pre-filters					x				6-20
Fan and alternator drive belt		x							6-20
Every 50 hours									
Air conditioner filters						x			6-21
Grease points (Bucket)	x								6-23
Every 250 hours									
Swing reduction unit oil		x							6-24
Travel reduction units oil		x							6-25
Engine primary air filter					x				6-26
Fuel pre-filters			x						6-29
Battery electrolyte level		x							6-31
Fan and alternator drive belt						x			6-34
Hydraulic oil tank					x				6-35
Tightening torques		x							6-36
Track shoe bolt torque		x							6-37
Track rollers and idler wheels		x							6-38
Cab protection system		x							6-38
Every 500 hours									
Turntable bearing	x								6-39
Engine oil and filter				x					6-41
Fuel filter			x						6-43
Radiator and coolers					x				6-44
Every 1000 hours									
Grease points (Boom and arm)	x								6-45
Hydraulic tank breather			x						6-48
Engine air filters			x						6-49
Hydraulic fluid analysis		x							6-52
Engine valve rocker clearance adjustment		x							6-52
Swing reduction unit oil				x					6-53
Alternator		x							6-54
Starter motor		x							6-54
Every 2000 hours									
Travel reduction units oil		x							6-55

Grease points (Bucket)

Grease the bucket linkage every 50 h.

Lubricant: **CASE AKCELA 251H EP MULTI-PURPOSE GREASE.**

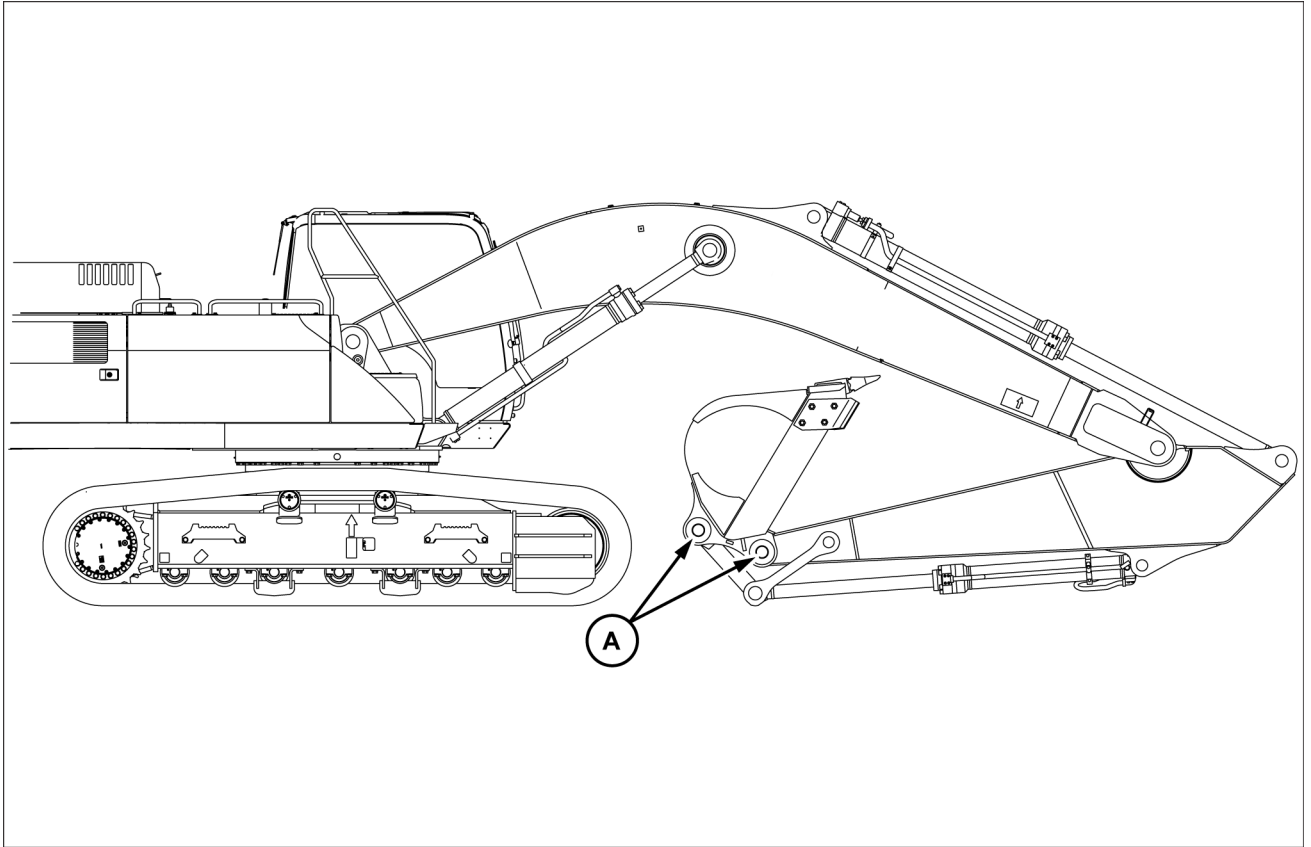

SMIL16CEX2146FB 1

NOTE: the bucket linkage shall be lubricated every 10 h if non-genuine grease is used.

Bucket linkage: two grease fittings.

NOTICE: the bucket linkage shall be lubricated every 10 h if the machine is operated in water or mud.

NOTICE: the bucket linkage shall be lubricated every 10 h if any attachment other than a bucket is used.

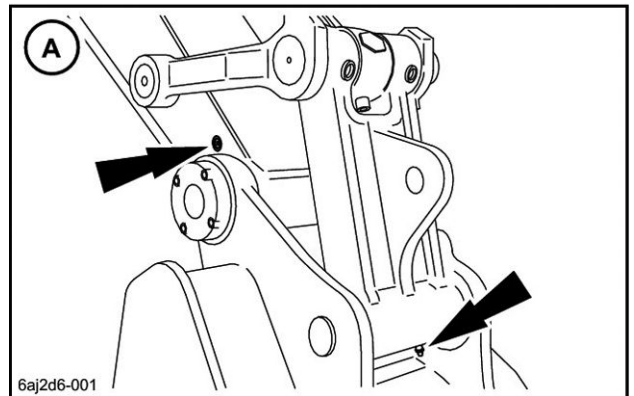

6AJ2D6-001 2

Starting the engine with booster batteries

⚠ WARNING

Improper operation or service of this machine can result in an accident.

An error connecting auxiliary starting cables or short-circuiting battery terminals can cause an accident. Connect auxiliary starting cables as instructed in this manual.

Failure to comply could result in death or serious injury.

W0263A

Make sure that the booster battery voltage corresponds to the voltage system of the machine **24 V**.

Make sure that the starter key is in OFF position and the gate lock lever in inward position.

Make sure to use supply cables of appropriate dimensions (at least **50 mm² (0.1 in²)**).

1. Connect one terminal of the positive jumper cable (**P**) to the positive (+) pole of the machine batteries.
2. Connect the other terminal of the positive jumper cable (**P**) to the positive (+) pole of the booster batteries.
3. Connect one terminal of the negative jumper cable (**N**) to the negative (-) pole of the booster batteries.
4. Connect the other terminal of negative jumper cable (**N**) to the upper frame of the machine (ground).

Turn the starter key to ON position and start the engine. After the engine has started proceed as follows:

1. Disconnect the terminal of negative jumper cable (**N**) from the upper frame of the machine (ground).
2. Disconnect the other terminal of the negative jumper cable (**N**) from the negative (-) pole of the booster batteries.
3. Disconnect the terminal of the positive jumper cable (**P**) from the positive (+) pole of the booster batteries.
4. Disconnect the other terminal of the positive jumper cable (**P**) from the positive (+) pole of machine batteries.

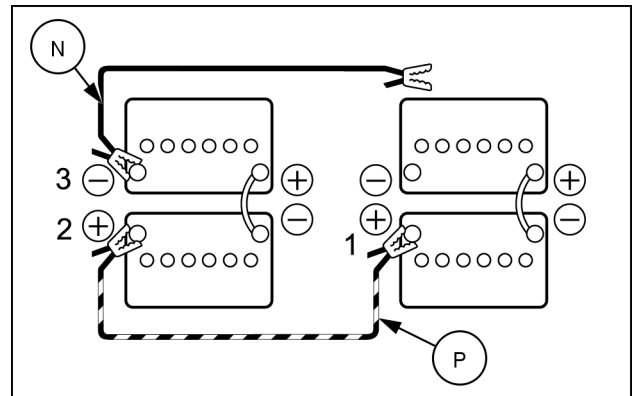

SMIL15CEX5131AA 5

Fuel filter

⚠ WARNING

Fire hazard!

When handling diesel fuel, observe the following precautions:

1. Do not smoke.
2. Never fill the tank when the engine is running.
3. Wipe up spilled fuel immediately.

Failure to comply could result in death or serious injury.

W0099A

Replace the fuel filter element every **500 h**

NOTICE: Do not work in any environment in which anything other than fuel will get into fuel lines. (Sites with strong wind, blowing dust, etc.). Wash hands before operations. Do not use gloves. Do not open the packaging for the filter kit until you start the installation work. Do not reuse any fuel remaining within the cover. For persistent dirt within the cover, wipe it off with a clean rag, then clean with clean diesel fuel. Do not use parts cleaner because it could affect the case cover. Do not touch the inside of the element. Completely wipe off any spilled fuel after changing the filter element.

NOTE: If using a fuel filter other than the CASE CONSTRUCTION genuine filter, you will no longer be guaranteed against the trouble caused by use of the wrong filter.

Take the same procedure as that for the pre-filter.

NOTE: the tightening torque of the filter cartridge must be **23 – 27 N·m (17.0 – 19.9 lb ft)**

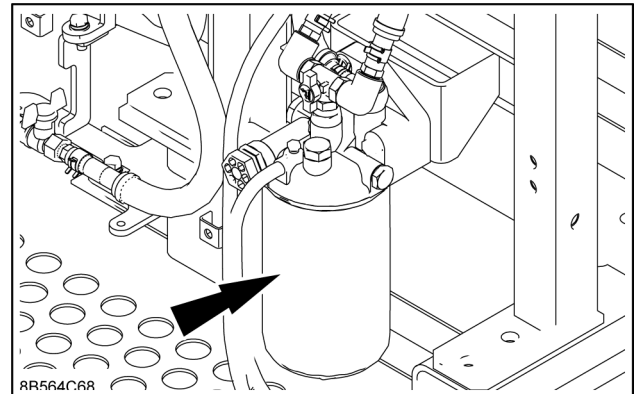

8B564C68 1

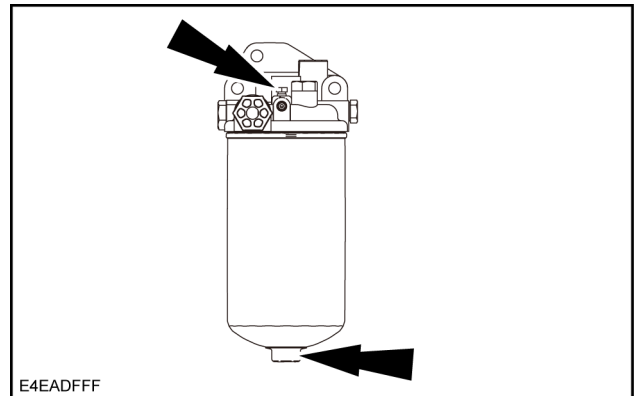

E4EADFFF 2

Bleed the fuel system. Refer to page **6-9**.

Swing reduction unit oil

⚠ WARNING

Hot surface possible!
Wait for all components to cool before performing any operation.
Failure to comply could result in death or serious injury.

W0251A

Replace the swing reduction unit oil every **1000 h** (After **250 h** of operation in run-in period).

Lubricant: **CASE AKCELA GEAR LUBE 135 H EP 80W-90.**

Quantity: **5 L (1.3 US gal).**

1. Park the machine on a flat and level place. Stop the engine, and remove the starter key.
2. Remove the oil gauge (1). Clean it with a neat cloth.

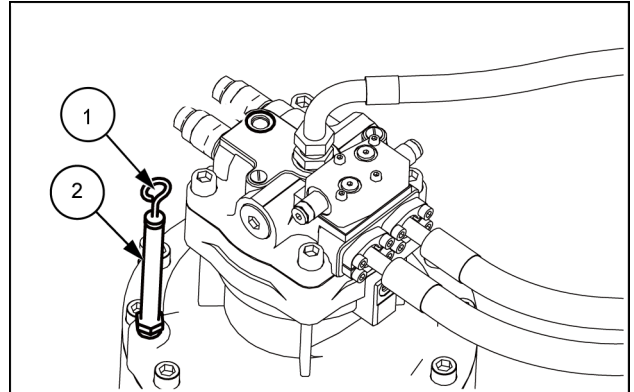

SMIL15CEX0219AB 1

3. Place a container with an appropriate capacity under the upper structure frame, remove the oil drain plug (3) to drain oil.

NOTE: Draining oil requires a comparatively long time.

NOTE: Check the condition of the drained oil. If foreign objects, such as metal scrapings, are included, consult the CASE CONSTRUCTION dealer.

4. Attach the drain plug (3).
5. Supply oil via the filler neck (2).
6. Attach the oil gauge (1) and check that the oil level is in the hatched area.
7. Wait for **10 min** and check the oil level again.
 If necessary, supply additional oil via the filler neck (2).

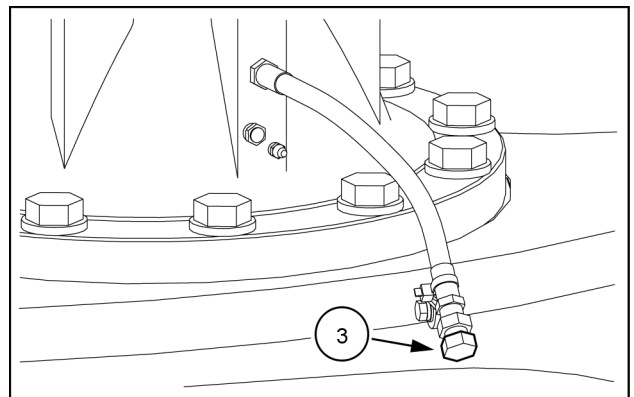

SMIL15CEX0220AB 2

Filling the engine cooling system

17. Close the coolant drain cock of the radiator and close the coolant drain plug on the engine block.
18. Loosen the air bleed plug on the EGR cooler.
19. Slowly supply coolant through the radiator coolant inlet. Add coolant up to the edge of the coolant inlet.

NOTICE: the coolant shall be added slowly in order to prevent the entry of air into the engine cooling system.

NOTE: push and release the radiator hoses while supplying coolant into the radiator to ease the flowing of the engine coolant into the cooling system.

20. Tighten the air bleed plug on the EGR cooler when coolant overflows from it.

Tightening torque: **20.0 – 24.0 N·m (14.8 – 17.7 lb ft)**

21. Close the radiator cap.
22. Fill the reserve tank with coolant up to the FULL mark. Close the cap of the reserve tank.
23. Start the engine and let it run at low idle speed for **3 – 5 min**, and then stop the engine.
24. Wait until the engine has cooled down. Slowly open the radiator cap and check for coolant level. If needed, add coolant up to the edge of the coolant inlet of the radiator.
25. Close the radiator cap.

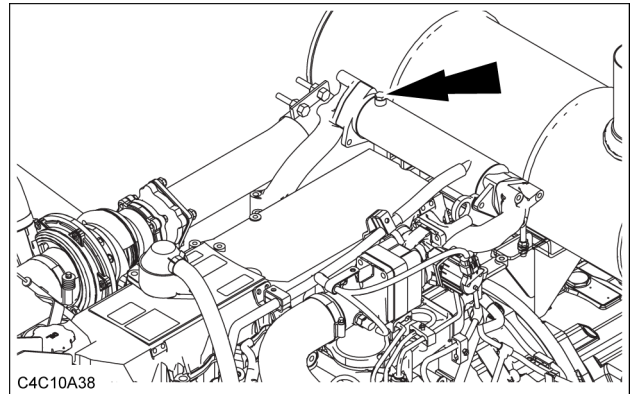

C4C10A38 8

Gas spring inspection

⚠ WARNING

Explosive gas!

Gas struts contain high-pressure nitrogen gas. If handled improperly, they could explode.

- Do not disassemble.
 - Do not expose to flame or fire.
 - Do not puncture, weld, or melt.
 - Do not expose to shock by striking or turning.
 - The fill gas must be removed before disposal. Consult your dealer.
- Failure to comply could result in death or serious injury.

W0914A

Check the gas springs periodically

The cab sunroof and the front storage box are supported by gas springs. In the following cases, request inspection, service, and replacement from the CASE CONSTRUCTION dealer:

- The cab sunroof or the front storage box does not open without force.
- The cab sunroof or the front storage box does not remain open.
- Oil or gas leak is found in the gas spring.

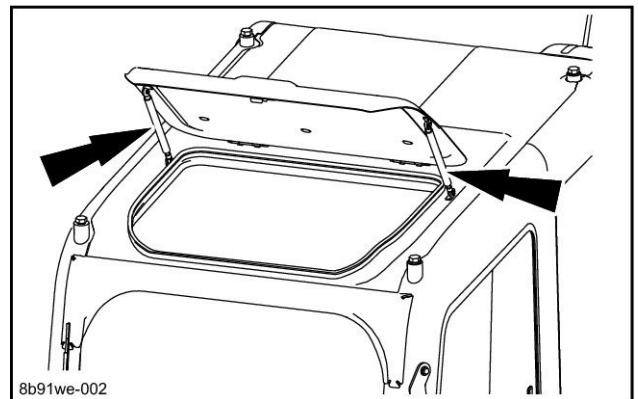

8B91WE-002 1

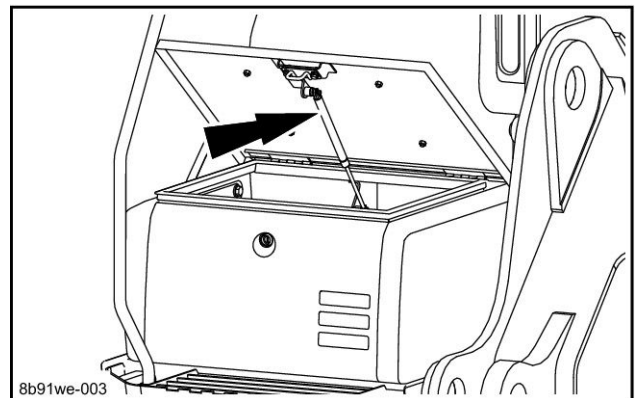

8B91WE-003 2

Fuse functions

- (1) Key switch: **15 A**
- (2) Engine computer: **20 A**
- (3) GPS computer: **10 A**
- (4) Back-up (radio, room lamp): **10 A**
- (5) Function cancellation lever: **10 A**
- (6) Solenoid: **10 A**
- (7) Horn: **10 A**
- (8) Cab top light: **15 A**
- (9) Boom, house light: **15 A**
- (10) Option power supply **15 A**
- (11) Wiper, washer: **15 A**
- (12) Rotary light: **10 A**
- (13) Cigar lighter, seat suspension: **10 A**
- (14) DC converter: **10 A**
- (15) Air conditioner unit: **5 A**
- (16) Air conditioner blower motor: **15 A**
- (17) Air conditioner compressor: **5 A**
- (18) Option power supply: **10 A**
- (19) Feed pump: **15 A**
- (20) Option line solenoid: **10 A**

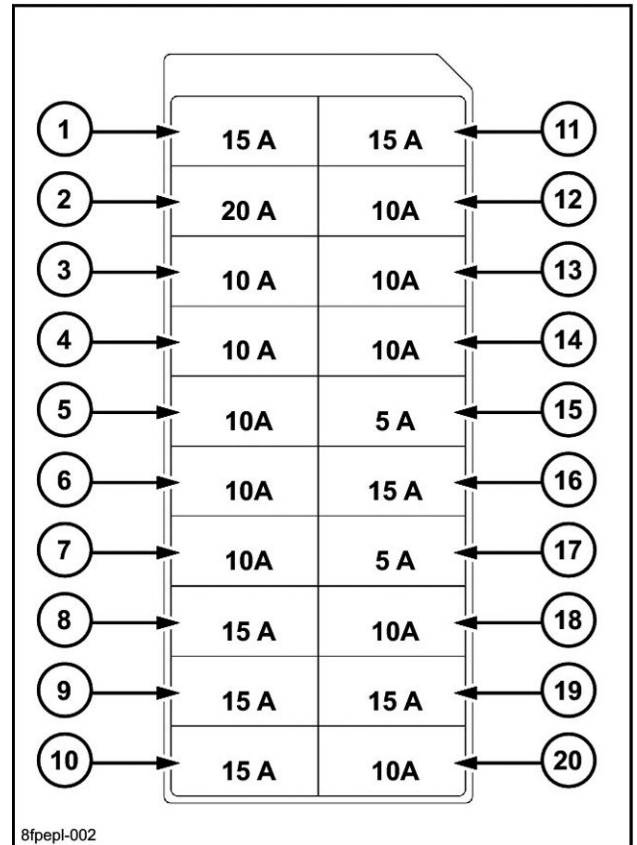

8FPEPL-002 3

NOTE: The roof lamp and the radio have an additional external fuse location. A fuse (21) of 10 A is located under the right rear of the operator's seat.

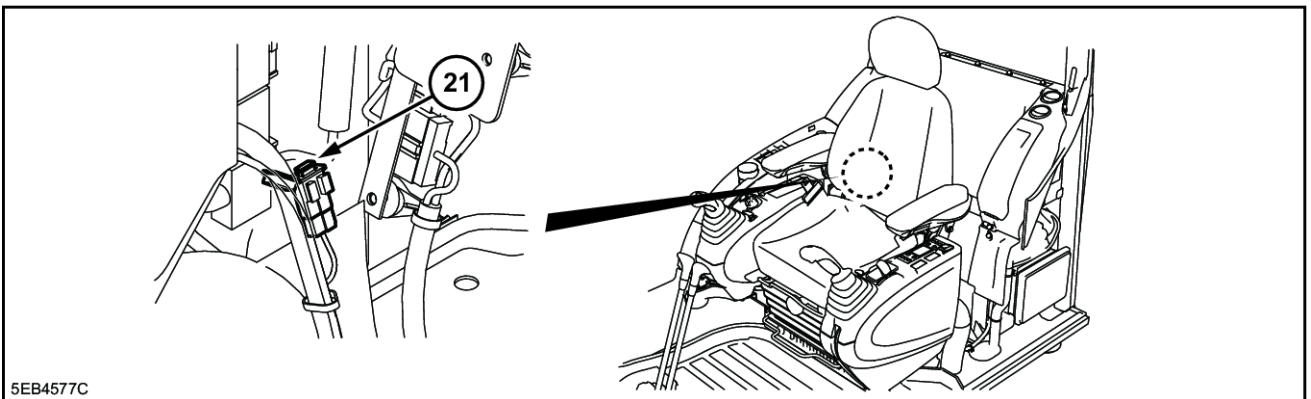

5EB4577C

5EB4577C 4

Fuel

Use only Low Sulphur Diesel fuel that meets GB 252:2011 specifications.

NOTICE: *Never use Diesel fuel having a sulphur content higher than 350 ppm.*

Using other types of fuel may lead to stalled engine output or deterioration in fuel economy.

NOTICE: *The warranty shall be invalid if any serious defect is caused by usage of any other fuel. Using any fuel other than the prescribed type will cause damages to the fuel supply system, to the fuel injection system, and to the engine block. CASE CONSTRUCTION will not be responsible to any of such damages.*

If the temperature drops below the fuel cloud point, output deficiency or engine start problems may occur due to wax crystals.

NOTICE: *If operating in severe winter climate, consult the fuel supplier or the CASE CONSTRUCTION dealer for specific diesel fuel to be used.*

The diesel fuel to be used on the machine shall:

- be free from dust particles, even minute ones.
- have the proper viscosity.
- have a high cetane number.
- present great fluidity at low temperatures.
- have low sulphur content.
- have very little residual carbon.

NOTICE: *Never use a mix of diesel fuel and old engine oil. The fuel injection system and the exhaust after treatment system will be severely damaged.*

NOTICE: *consult the fuel supplier or the CASE CONSTRUCTION Dealer regarding appropriate use of fuel additives.*

NOTICE: *in order to prevent condensation during cold weather, fill the fuel tank to full after completing the day's work.*

Fuel storage:

Long storage can lead to the accumulation of impurities and condensation in the fuel. Engine trouble can often be traced to the presence of water in the fuel. The storage tank must be placed outside and the temperature of the fuel should be kept as low as possible. Drain off water and impurities regularly.

Disposal of fluids, lubricants, and spare parts

Fluids, lubricants and spare parts used on the machine are not fully compatible with the environment. Make sure to carry out all maintenance operations using appropriate tools, in order to avoid any risk of damaging the environment.

NOTE: *for example, make sure that the receptacle for collecting oil to be replaced is not leaking.*

Never spread fluids or lubricants on the ground or into water. Consult the CASE CONSTRUCTION Dealer or the Local Environmental Agency in order to obtain information on the correct method of disposing fluids and lubricants used on the machine.

Never throw away spare parts as filters or batteries. Consult the CASE CONSTRUCTION Dealer or the Local Environmental Agency in order to obtain information on the correct method of disposing filters, batteries or other spare parts used on the machine.

8. Place the locking pin of the right-hand auxiliary pedal in outward position.

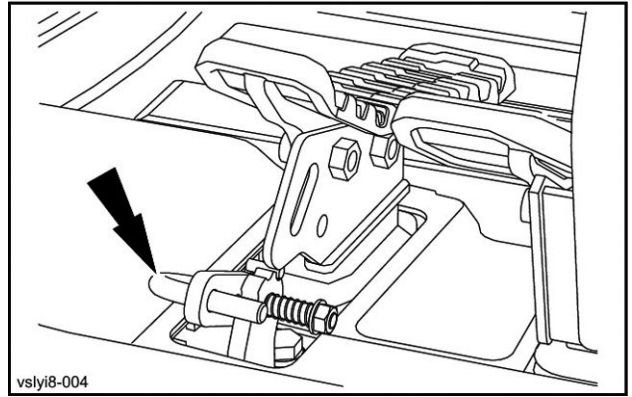

VSLY18-004 12

9. Press one side of the right-hand pedal to close the crusher jaws, and press the other side of the pedal to open the crusher jaws. The crushing force increases with the pressing on the pedal in the closing direction. Release the pedal to hold the crusher jaws in position.

NOTICE: in bucket mode, do not carry out operation using auxiliary line. If you do that, the warning message "Auxiliary set-up required" will be displayed with intermittent whistle sound. Stop operation immediately and carry out auxiliary set-up.

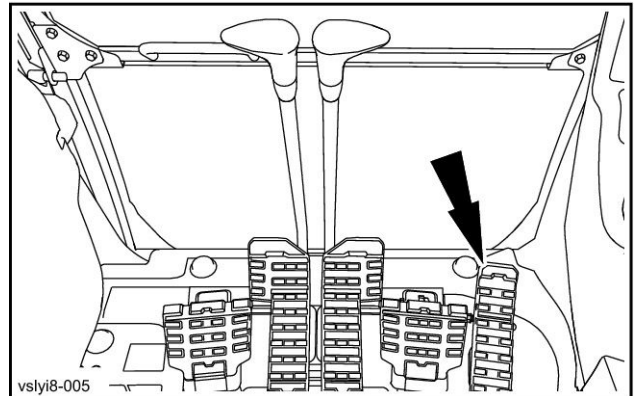

VSLY18-005A 13

NOTICE: the auxiliary pedal shall always be locked when not in use.

To lock the auxiliary pedal, engage the locking pin (1) in the locking hole (2).

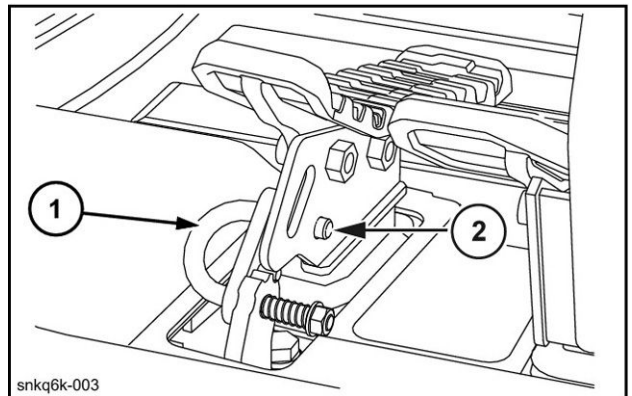

SNKQ6K-003A 14

CLICK HERE TO **DOWNLOAD** THE COMPLETE MANUAL

- Thank you very much for reading the preview of the manual.
- You can download the complete manual from: www.heydownloads.com by clicking the link below



- Please note: If there is no response to CLICKING the link, please download this PDF first and then click on it.

CLICK HERE TO **DOWNLOAD** THE COMPLETE MANUAL