

# **CX290B** **Crawler excavator**

## Operator's Manual

**Print No. Lep 47462337**

3<sup>rd</sup> edition

English 12/2012 - Original Instructions

Replaces Lep 84403127



CLICK HERE TO **DOWNLOAD** THE COMPLETE MANUAL

- Thank you very much for reading the preview of the manual.
- You can download the complete manual from: [www.heydownloads.com](http://www.heydownloads.com) by clicking the link below



- Please note: If there is no response to CLICKING the link, please download this PDF first and then click on it.

CLICK HERE TO **DOWNLOAD** THE COMPLETE MANUAL

## TABLE OF CONTENTS

---

### Specifications (continued)

Monobloc boom .....	11-4
Dippers .....	11-4
Backhoe buckets .....	11-5
Machine overall dimensions .....	11-6
Working range .....	11-8
Quick coupler .....	11-9
<b>SECTION 12 - ALPHABETICAL INDEX .....</b>	<b>12-1</b>

**DESCRIPTION OF THE MAIN COMPONENTS**

The **CX290B** is a totally hydraulic excavator. It consists of an undercarriage fitted with tracks and a turntable bearing which supports the upperstructure frame. The upperstructure frame supports the attachment, at the front end of the machine, plus the engine, hydraulics and cab. When the operator works the controls, the engine-driven pump delivers hydraulic fluid to the control valves. The control valves distribute the hydraulic fluid to the various cylinders and hydraulic motors employed. A cooling system maintains the hydraulic fluid at normal operating temperature.

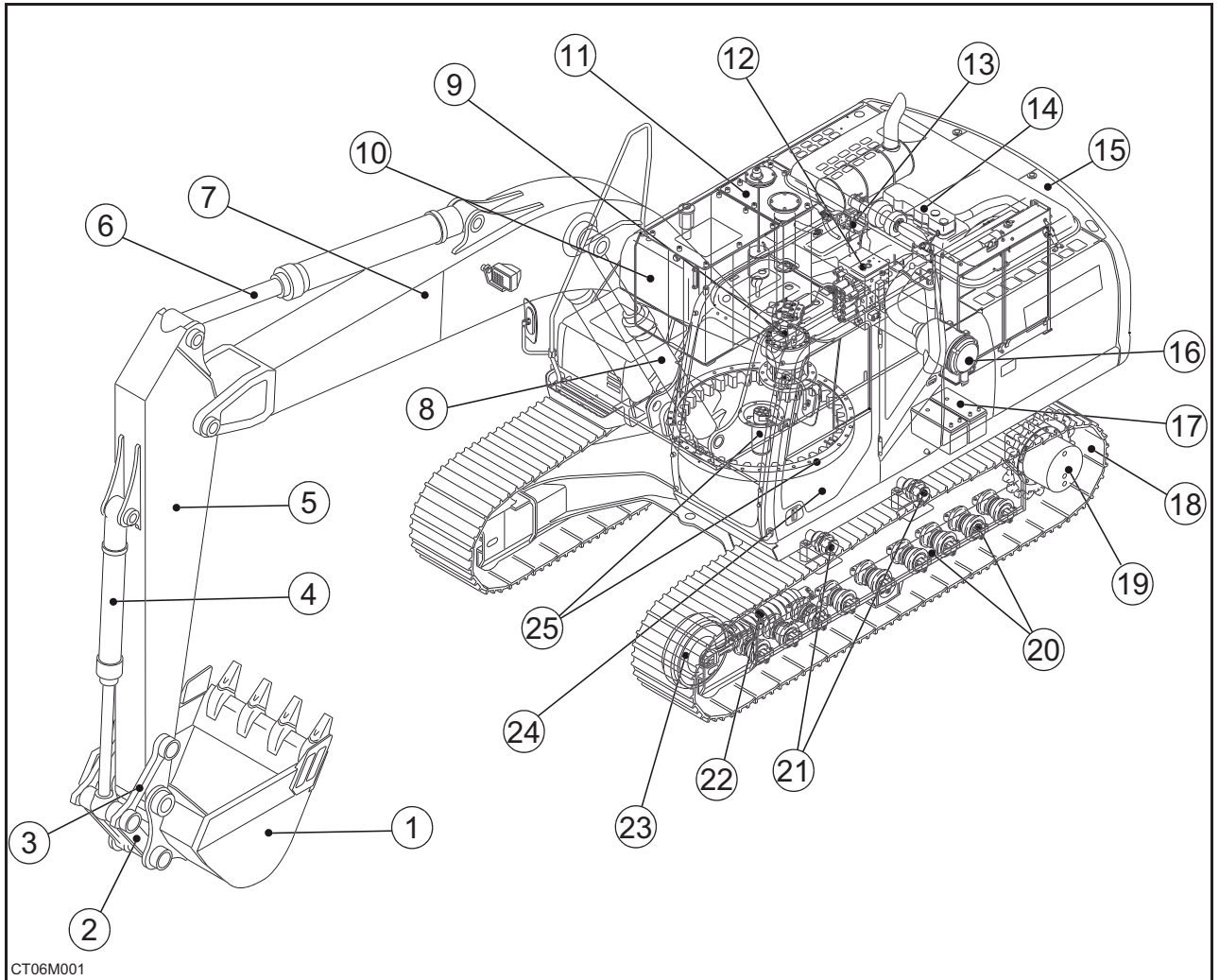

CT06M001

- |  |   |
|--|---|
| <ul style="list-style-type: none"> <li>6. Backhoe bucket</li> <li>7. Connecting rod</li> <li>8. Yokes</li> <li>9. Backhoe bucket cylinder</li> <li>10. Dipper</li> <li>11. Dipper cylinder</li> <li>12. Boom</li> <li>13. Boom cylinders</li> <li>14. Swing reduction gear</li> <li>15. Fuel tank</li> <li>16. Hydraulic reservoir</li> <li>17. Control valve</li> <li>18. Hydraulic pump</li> </ul> | <ul style="list-style-type: none"> <li>19. Engine compartment</li> <li>20. Counterweight</li> <li>21. Air filter</li> <li>22. Batteries</li> <li>23. Tracks</li> <li>24. Travel reduction gears</li> <li>25. Lower rollers</li> <li>26. Upper rollers</li> <li>27. Tension shock absorbers</li> <li>28. Idler wheels</li> <li>29. Cab/Operator's compartment</li> <li>30. Swing components</li> </ul> |
|--|---|

**DECALS**



An illegible or missing decal can have far-reaching consequences. Inspect decals daily.



Make sure that the decals are perfectly legible, clean them regularly and replace decals that are destroyed, lost, painted over or no longer legible, with new ones. When parts bearing decals are replaced, be sure to put new decals on each new part.

**NOTE:** When you clean the decals, use only a cloth, water and soap. Do not use solvents, gasoline, etc.

**NOTE:** This chapter only covers decals relating to safety and machine operation and servicing. For information on all decals on the machine, consult the spare parts catalogue.

**POSITION OF DECALS**

See the "Illustration of decals" for the functions of decals.

When replacing a decal, make sure it is located as shown below.

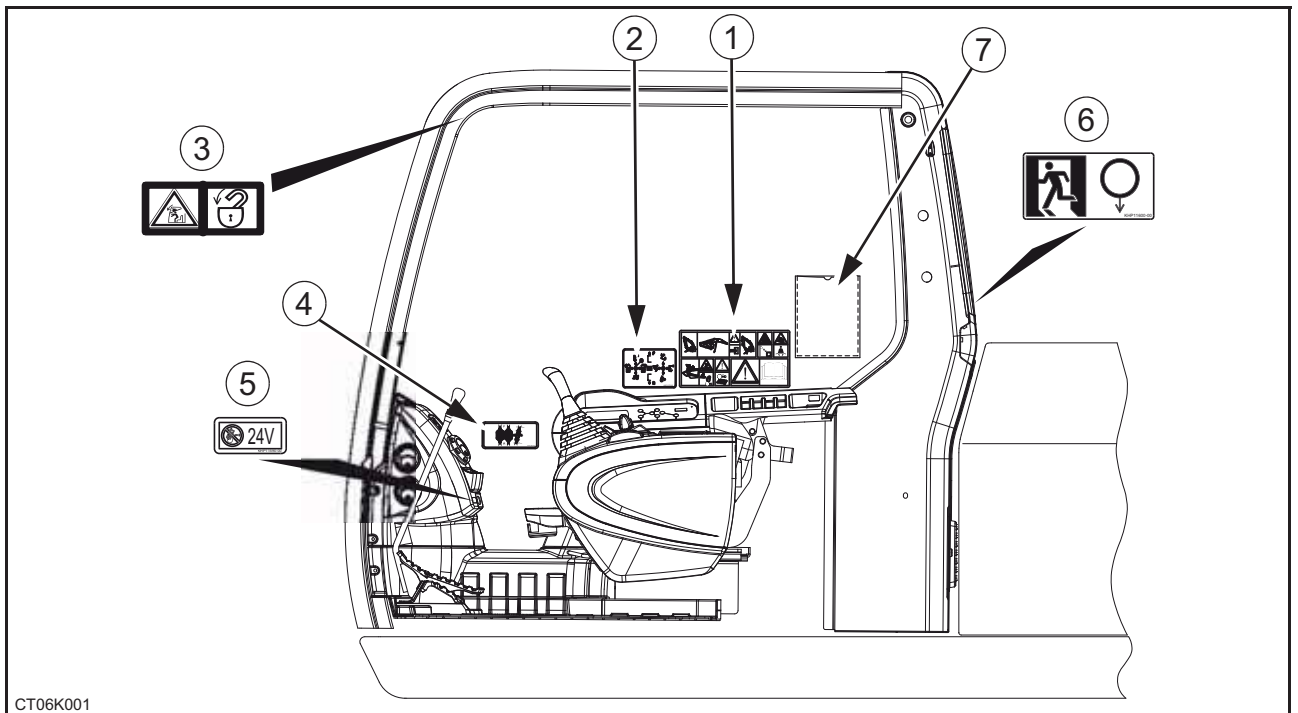

CT06K001

**BATTERIES**

This decal is on the batteries and draws attention to the risks and precautions to be taken when handling batteries.

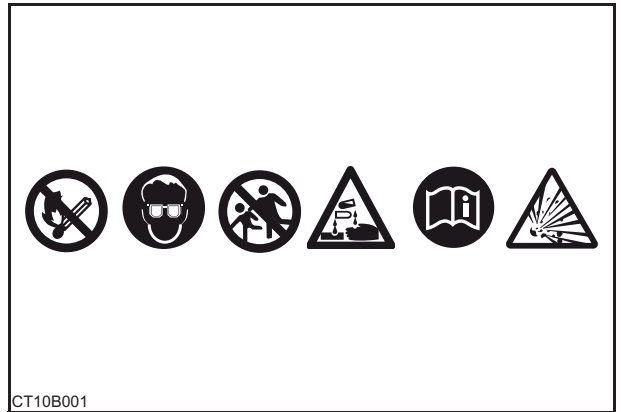

35

**QUICK COUPLER (optional)**

Part number: 84236228

This decal shows the precautions to be taken to ensure that the implement is correctly installed on the quick coupler.

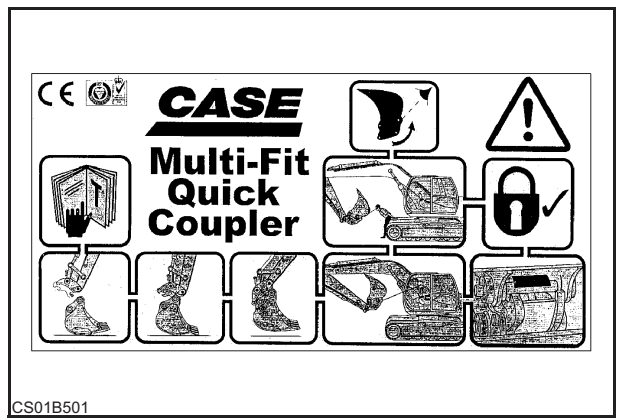

36

## SECTION 4 - CONTROLS/INSTRUMENTS/ACCESSORIES

---

### 6. OVERLOAD INDICATOR SWITCH

This control is to be used during load handling. Place the switch in the "ON" position. If the load to be lifted exceeds the authorized limit, the audible alarm will sound. In the "OFF" position the switch is non-operational. See "Load handling" in section 5.

***IMPORTANT:*** Before undertaking any load handling operations, place the switch in the "ON" position.

### 7. OPTION CONTROL (if equipped)

### 8. CAB RADIO COMPARTMENT

This pre-equipped compartment is provided for installing a 12 volts car radio (optional).

To operate the cab radio, consult the instruction manual supplied.

HEATING AND VENTILATION OR AIR CONDITIONING CONTROLS

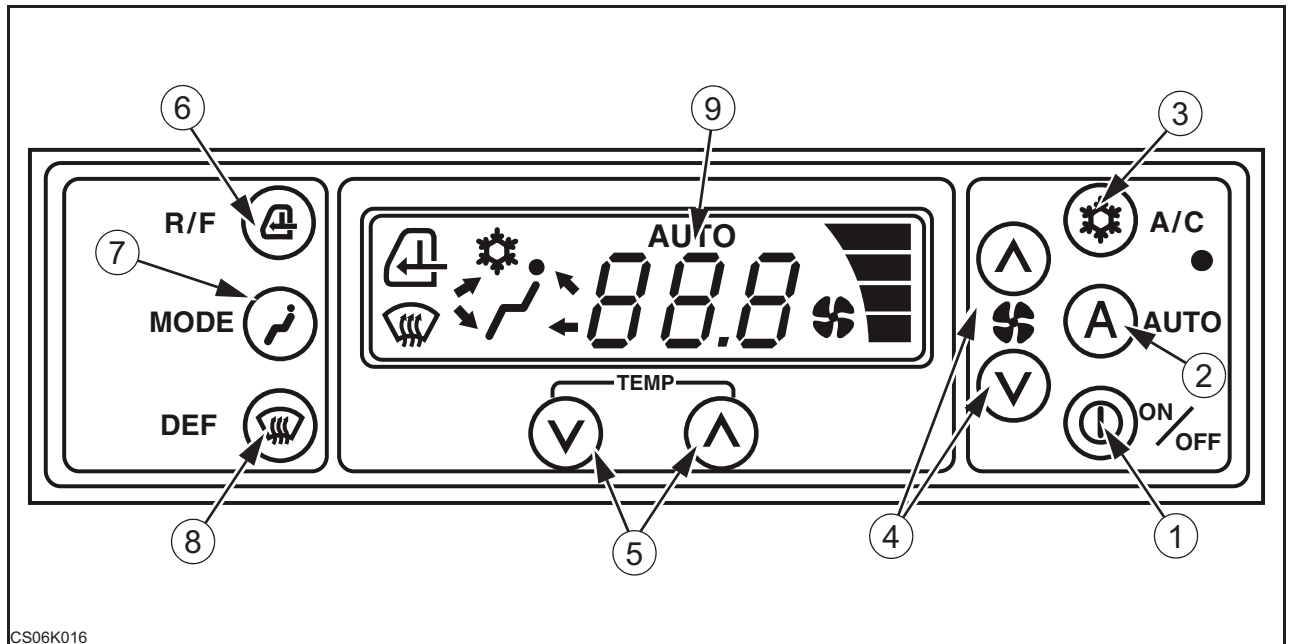

CS06K016

16

- 1. ON/OFF
- 2. Automatic
- 3. Air conditioning
- 4. Ventilation
- 5. Temperature
- 6. Air recycling
- 7. Air flow direction
- 8. Windshield defroster
- 9. Display screen

**ON/OFF**

This push-button (1) is for turning the system on or off.

**NOTE:** When the system is turned on it will operate at the same setting as the one selected previously.

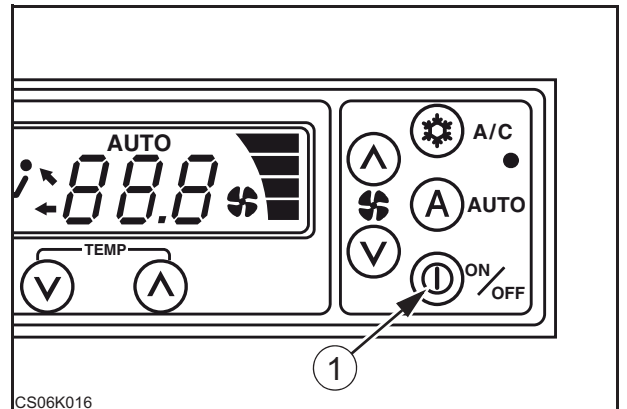

CS06K016

17

### CAB DOOR SLIDING WINDOWS

When the locks are released, the windows can be opened and closed to the left or right as required.



46

### SUN SHIELD

The sun shield is fixed to the windshield and can easily be positioned as required.

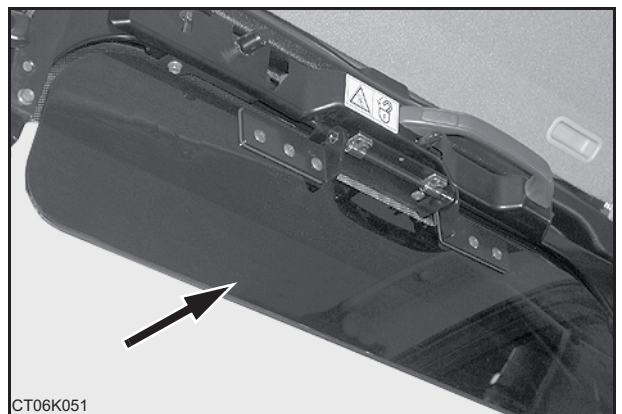

47

### MAGAZINE RACK

Located on the right-hand side, behind the operator's seat.



48

### REFRIGERATED COMPARTMENT

Located on the right-hand side, behind the operator's seat. This compartment, associated with the air conditioning system, is designed to store different cold or hot products, drinks, etc.



49

## SIDE DOORS

Use the outside handle to open the doors. To hold the doors, open, remove the struts from their storage position and install them in the holes provided. When closing, put the struts back into their storage housing.

Use the starter switch key to lock the side doors.

### RIGHT-HAND DOOR

The right-hand door gives access to certain hydraulic components (pump, filter, etc.) and also to the engine fuel and oil filters.

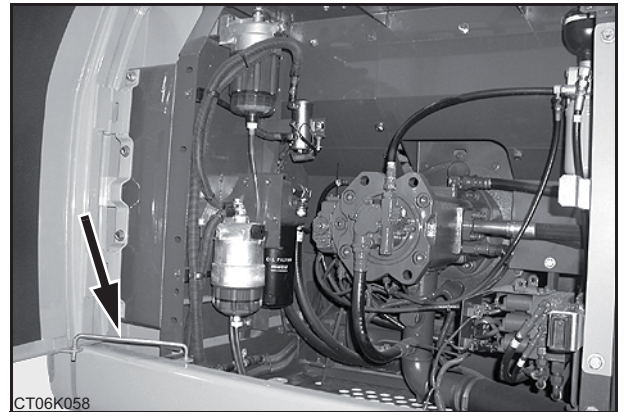

73

### LEFT-HAND DOORS

The left-hand door is mainly for obtaining access to the batteries, battery master switch, windshield washer tank, air filter, radiator, oil cooler, etc.

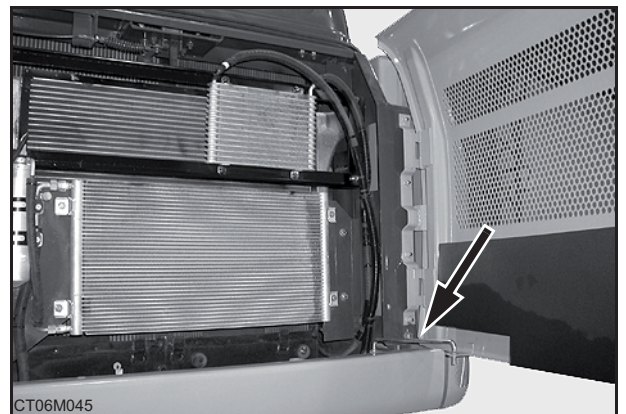

74

————  **WARNING**  ————

Always install the struts when the doors are open.

————  **WARNING**  ————

Never leave tools or other objects behind the side doors.

————  **WARNING**  ————

Before undertaking any travel, make sure the side doors are properly closed.

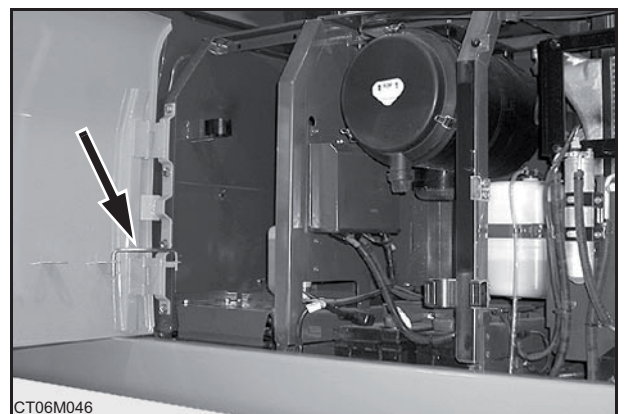

75

## SECTION 5

### OPERATING INSTRUCTIONS

#### BEFORE USING THE MACHINE



Do not attempt to operate this machine unless you have first read and perfectly understood the safety messages and instructions appearing in this manual.

---

Before operating this machine, be sure to do the following:

1. Check the level of all fluids (engine oil, hydraulic fluid and coolant) and make sure that the fluids and lubricants are suitable for prevailing conditions. See "Fluids and lubricants" in section 7 and "Operating the machine in cold weather".
2. Carry out the daily maintenance operations. See section 6.
3. Inspect the machine, look for any signs of possible leakage and check the hoses. Tighten or replace as necessary. See section 8.
4. See "Run-in period" if the machine is new or if the engine has been reconditioned.
5. Check the track assemblies. See "Tracks" in section 8.
6. Clean the steps and access handles. Grease, oil, mud or ice (in winter) on the steps and access handles can cause accidents. Make sure they are kept clean at all times.
7. Clean or replace any decals which are illegible. See "Decals" in section 3.
8. Make sure that the engine hood and the side doors are properly closed and latched.
9. Secure the cab door in either fully closed or fully opened position. See "Cab door" in section 4.
10. Remove any obstructions which hinder visibility. Clean the windshield, the windows and the rear view mirrors.
11. Check that no tools or other items have been left on the machine (be it on the undercarriage or the upperstructure) or in the operator's compartment.
12. Make sure nobody is on or under the machine. The operator must be alone on the machine.
13. Make sure nobody is standing in the machine working area.
14. Find out about current safety measures in use on the work site.
15. Work out a convenient means of escape from the machine (emergency exit via the windshield, the rear window glass) in the event of the machine turning over or tipping over or the cab door being jammed. See "Windshield" and "Rear window (emergency exit)" in section 4.
16. Before undertaking any travel or working operations during hours of darkness, make sure the lighting and signalling equipment is fully operative.

## STOPPING THE ENGINE

1. Lower the attachment until it is resting on the ground.
2. Turn the engine throttle button (1) to low idle position and let the engine run for a minute or so.

**IMPORTANT:** In cold weather, let the engine run for about five minutes at idle speed.

**IMPORTANT:** Always let the engine run at idle before switching off completely, except in emergency situations.

3. Turn the starter switch key (2) to the "OFF" position.
4. Place the key of the battery master switch in "O" (Off) position.

**NOTE:** To activate the anti-theft device when stopping the engine, see "Anti-theft device".

**IMPORTANT:** When the engine is to be shut down for a considerable length of time, see "Parking the machine".

## IN THE EVENT OF AN EMERGENCY

In the event of an emergency or if it is not possible to stop the engine using the contact switch key, press the emergency shut-down switch on the LH control arm. See "LH control arm" (item 9) in section 4

**IMPORTANT:** This switch should only be used in case of an emergency. Do not use it on a day-to-day basis to stop the engine.

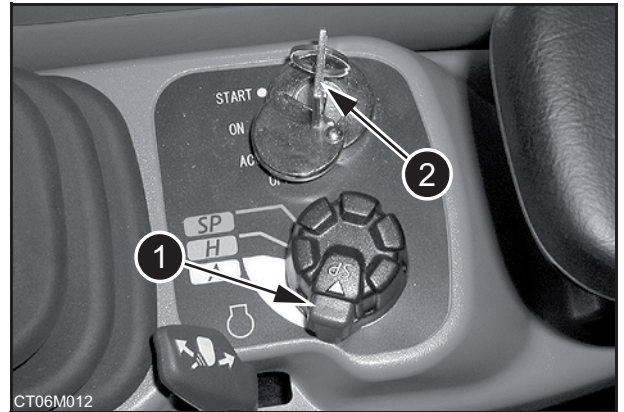

11



12

## OPERATING THE MACHINE ON SLOPING GROUND



Hillside operations can be dangerous. Rain, snow, ice, loose gravel, soft ground, etc. modify terrain conditions. It is up to you to decide if the machine can be used in perfect safety.

---



Before parking the machine, make sure that the ground is stable. Plan the worksite so that the ground is flat, hard and level.

---

- During hillside operations, be extra careful.
- Make sure that the low speed travel is selected.
- When digging on a slope, avoid swinging the upper-structure towards the bottom of the slope with the backhoe bucket full. Always keep the travel reduction gears pointing down towards the bottom of the slope.
- Always travel in the same direction as the slope, to prevent the machine from turning over.

CLICK HERE TO **DOWNLOAD** THE COMPLETE MANUAL

- Thank you very much for reading the preview of the manual.
- You can download the complete manual from: [www.heydownloads.com](http://www.heydownloads.com) by clicking the link below



- Please note: If there is no response to CLICKING the link, please download this PDF first and then click on it.

CLICK HERE TO **DOWNLOAD** THE COMPLETE MANUAL

## SECTION 5 - OPERATING INSTRUCTIONS

---

### TOWING A LOAD

To tow a load of up to 10 tons, use the towing hole provided for this purpose. See "Towing holes" in section 4.

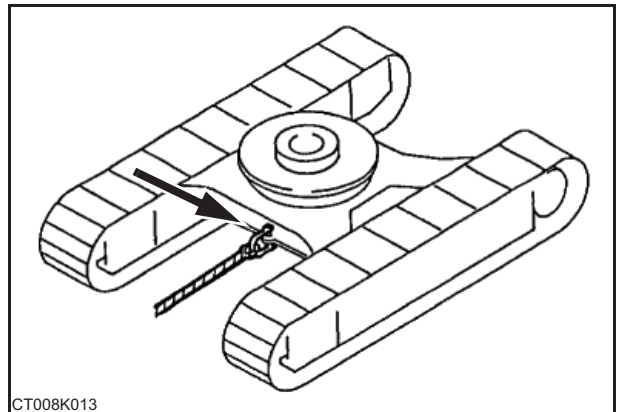

CT008K013

## SECTION 5 - OPERATING INSTRUCTIONS

3. Select low travel speed, indicator lamp off.

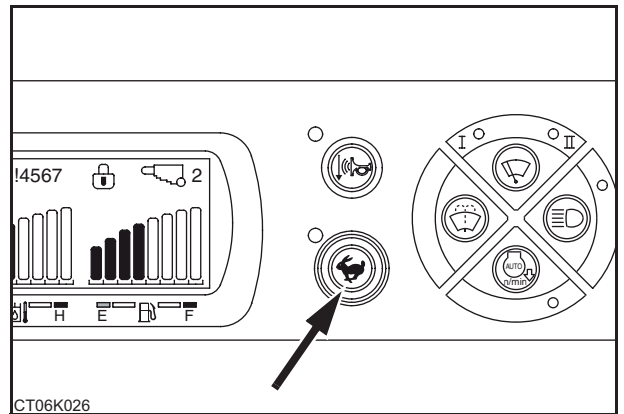

71

### 4. (Machine with attachment)

Place the machine in line with the trailer, with the travel reduction gears towards the access ramps. Raise the attachment and bring it to about twenty centimetres above the bed of the trailer.

**IMPORTANT:** In this position, the travel and steering controls are reversed.

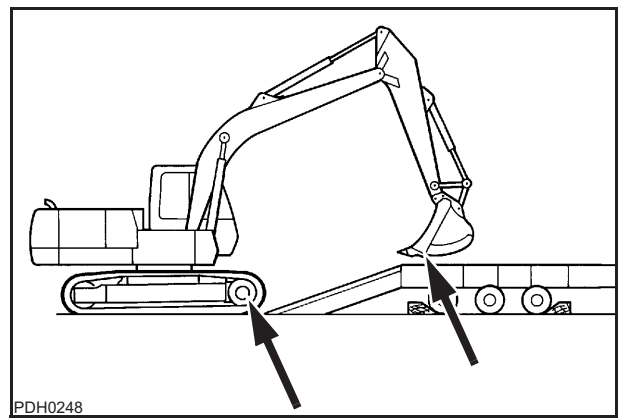

72

### 5. (Machine without attachment)

Place the machine in line with the trailer, with the travel reduction gears towards the access ramps.

**IMPORTANT:** In this position, the travel and steering controls are reversed.

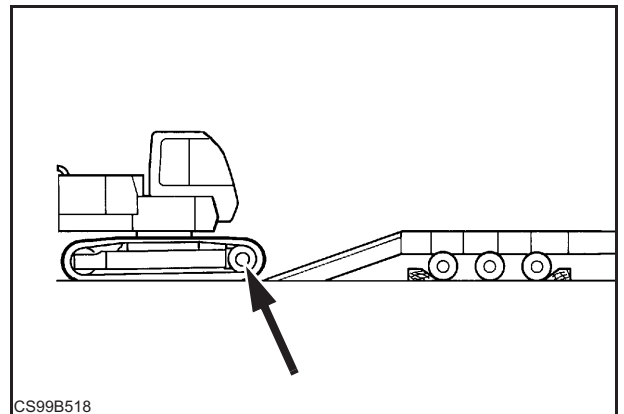

73

## SECTION 6 - SERVICING INTERVALS

---

- (Q) Replace after the first 250 hours during the run-in period.
- (R) If biodegradable fluid is used, it is imperative for the servicing interval to be reduced to 1000 hours.
- (S) Or every 2 years, whichever comes first.
- (T) If biodegradable fluid is used, it is imperative for the servicing interval to be reduced to 2000 hours.
- (U) Have this checked every 6 months by your CASE Dealer.
- (V) Periodically.
- (W) Check once a month and have it checked every 6 months by a specialist.

**NOTE:** *Once the machine has completed 500 hours (then 1000 hours, 1500 hours, etc.) the message "SERVICE DUE" will appear on the screen (see "Message display in section 4) by way of a reminder that service work is due. (It is possible to increase this lapse of time. Consult your CASE Dealer).*

**(\* IMPORTANT:** *If the machine is equipped with a hydraulic breaker, it is imperative that the servicing intervals are reduced, see "Replacing the hydraulic filters and fluid when a hydraulic breaker is used" in section 7.*

SECTION 7 - LUBRICATION/FILTERS/FLUIDS

Dipper cylinder top pin ..... (1)

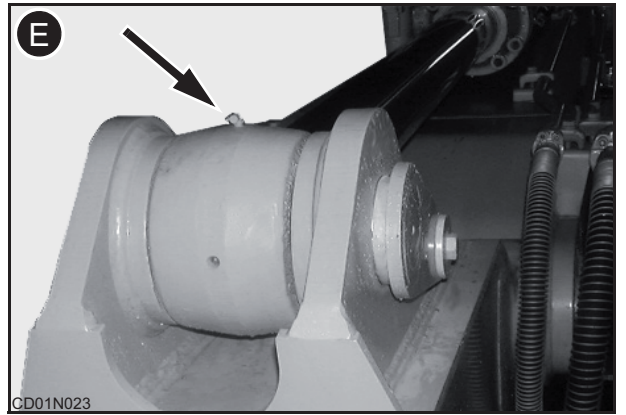

12

Bucket cylinder bottom pin ..... (1)

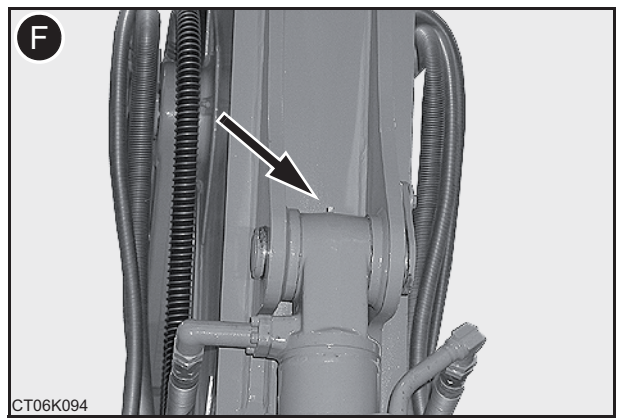

13

Yoke/connecting rod linkages ..... (4)

**IMPORTANT:** If an accessory other than the bucket is installed, (hydraulic hammer, etc.) these points must be lubricated every 10 hours.

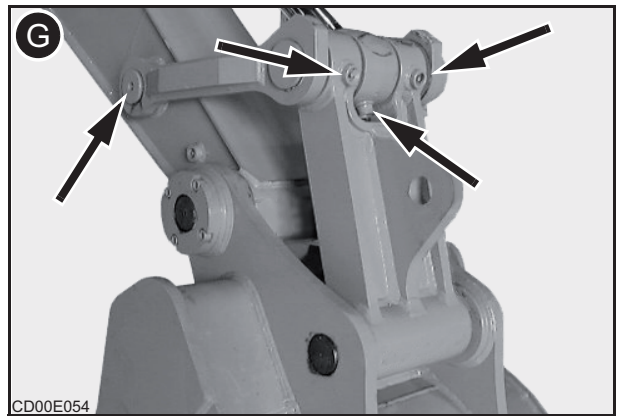

14

**LEVEL**

The level of coolant solution should be checked when the engine is cold.

On flat, level ground, before using the machine (while the engine is still cold), the level in the expansion reservoir should be between the "Full" (1) and "Low" (2) marks. If not, see "Filling".

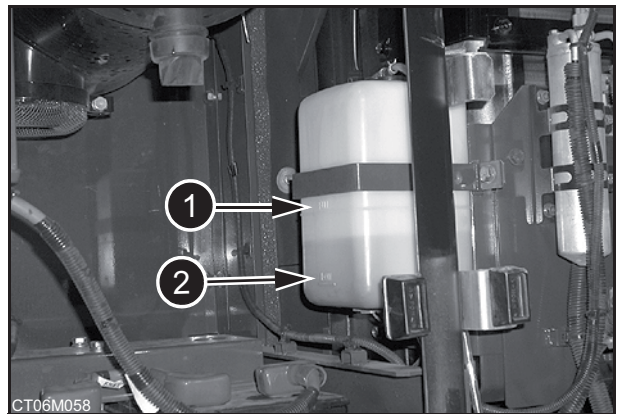

37

**DRAINING**

1. Remove the radiator plug.



Do not remove the radiator cap when the engine is hot. The system is still under pressure and you could be scalded.

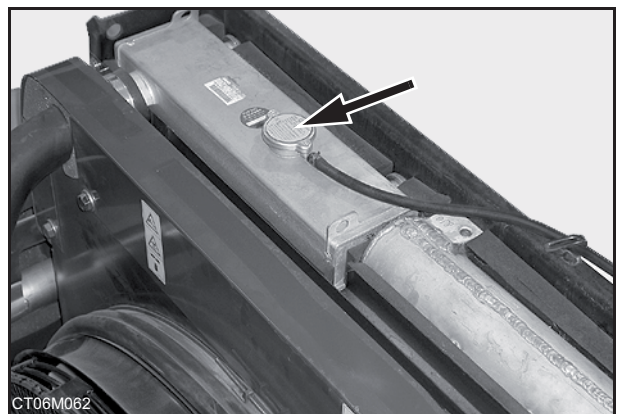

38

2. Open the radiator drain valve.

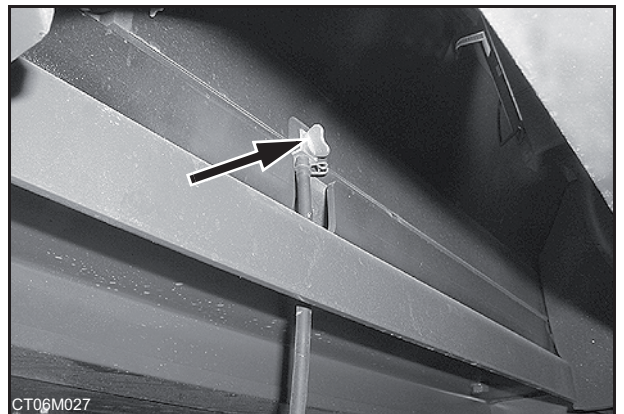

39

3. Open the drain plug located on the engine block.

**NOTE:** Have a receptacle of a suitable capacity ready.

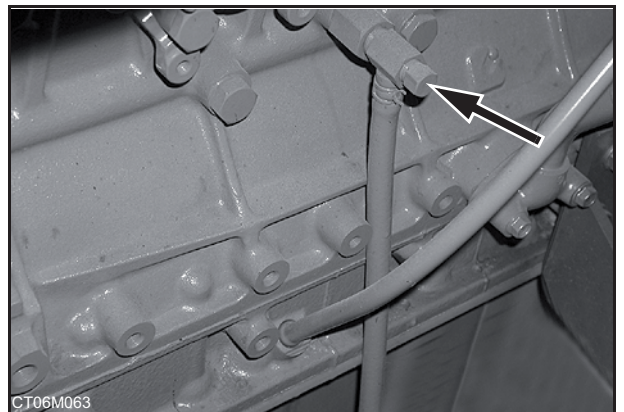

40

**HYDRAULIC SYSTEM**

**SERVICE SPECIFICATIONS**

Check the hydraulic reservoir fluid level .....	Every 10 hours or each day
Check the lines .....	Every 50 hours
Draining water and sediment from the hydraulic reservoir .....	Every 250 hours
Check the condition of the hydraulic fluid.....	Every 1000 hours
Change the reservoir breather filter element .....	Every 1000 hours
Clean the inlet filter .....	Every 2000 hours
Change the return filter.....	Every 2000 hours (after the first 250 hours during the run-in period)
Change the pilot filter.....	Every 2000 hours (after the first 250 hours during the run-in period)
Change the main pump outlet hoses.....	Every 2 years or every 4000 hours (whichever comes first)
Change the boom, dipper and bucket cylinder hoses .....	Every 2 years or every 4000 hours (whichever comes first)
Change the inlet filter.....	Every 5000 hours
Change the hydraulic fluid.....	Every 5000 hours
Reservoir capacity .....	147 litres
Total system capacity .....	300 litres
Oil type .....	See "Fluids and lubricants"

**IMPORTANT:** If biodegradable fluid is used, it is essential to reduce the following servicing intervals to the number of hours shown:

Change the return filter.....	Every 1000 hours (after the first 50 hours during the run-in period)
Change the hydraulic fluid.....	Every 2000 hours

**NOTE:** If the machine is new or if a major component has been overhauled or changed in the hydraulic system, change the pilot filter and return filter after 50 hours of operation. After that, change these filters at the stipulated interval.

**IMPORTANT:** Every 1000 operating hours, it is necessary to have the hydraulic fluid analysed. Consult your CASE Dealer.

**IMPORTANT:** After changing the hydraulic fluid, it is necessary to bleed all air from the hydraulic components. See "Bleeding air from the hydraulic components".

**IMPORTANT:** If metal particles are found in the old filters, consult your CASE Dealer.



Hydraulic fluid or grease injected into your skin can cause severe injury or death. Keep your hands and body away from any pressurized leak. Use cardboard or paper to check for a leak. If fluid is injected into your skin, see a doctor immediately and have the fluid removed.



Before carrying out any operation on the hydraulic filters or the hydraulic system, the pressure must be released from the system. Failure to observe this instruction can cause injury. See "Releasing pressure in the hydraulic system".



Before carrying out any service work on the hydraulic system it is necessary to allow it to cool down (the temperature should not be more than 40°C).

3. Remove the secondary element if it needs changing.

**IMPORTANT:** The secondary element must be changed, not cleaned.

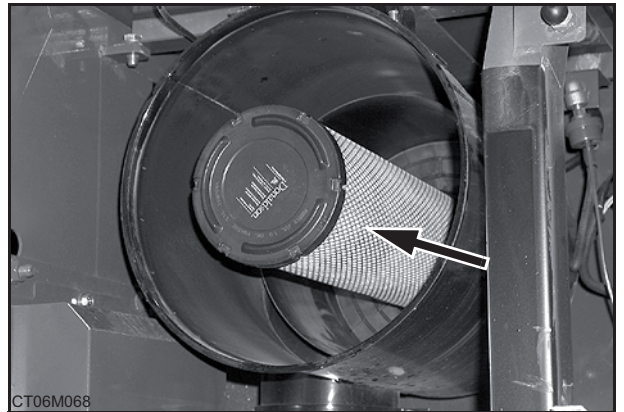

77

### CLEANING THE PRIMARY ELEMENT

**IMPORTANT:** Always protect your face before using compressed air.

If the primary element is dry:

Blow compressed air from the inside towards the outside at very low pressure. The compressed air nozzle should be held at least 3 cm from the inside wall of the element. Cleaning is completed once no more dust comes out of the primary element.

**IMPORTANT:** Compressed air pressure should not exceed 7 bar.

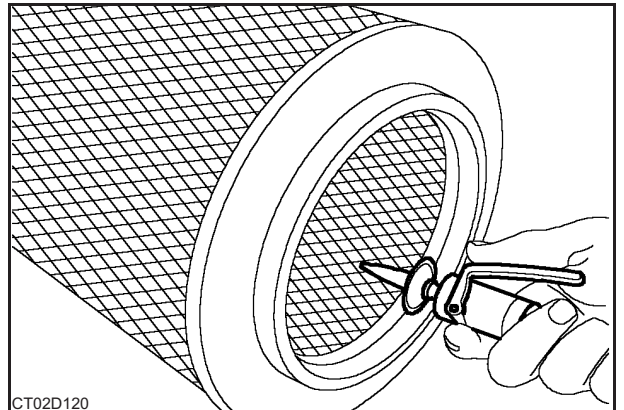

78

**NOTE:** Do not use compressed air if there is oil or soot in the element.

If the cartridge is greasy:

Clean it in water with a suitable detergent (consult your CASE Dealer). Instructions for using the detergent are printed on the packaging.

**IMPORTANT:** Allow the element to dry completely before installing it. It is advisable to keep a spare, clean element ready for installation on the air filter while the cleaned element is drying.

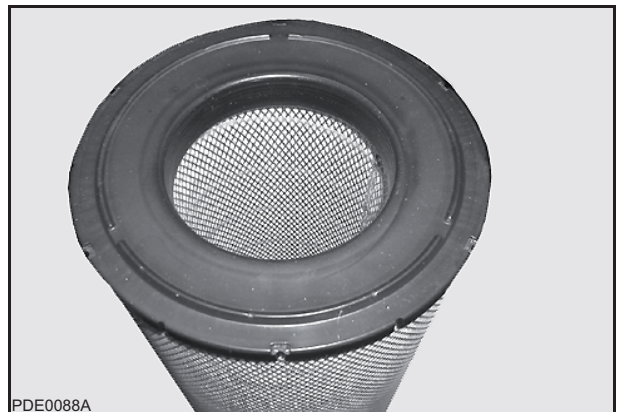

79

### ADJUSTING THE TENSION

**NOTE:** This operation is to be carried out after the tension has been checked.

#### To increase tension

1. Clean the grease fitting adaptor and the grease fitting.
2. Connect the grease pump. Inject grease to obtain the right amount of track sag.  
The value must be between: 330 mm and 360 mm.
3. Remove the grease pump and clean the grease fitting.
4. Repeat Steps 1 to 3 for the other track.

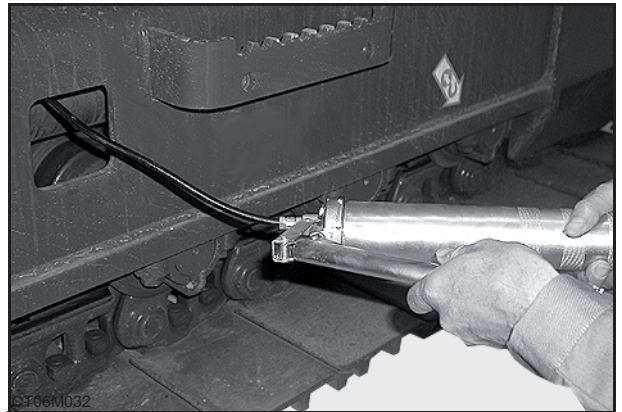

6

#### To reduce tension

1. Slowly loosen the grease fitting adaptor by about three turns to allow grease to flow out of the cylinder.



**WARNING**

Never unscrew the grease fitting adaptor completely to speed up the flow of grease. The grease in the cylinder is under high pressure.

2. As soon as the right track sag is obtained, tighten the adaptor.  
The value must be between: 330 mm and 360 mm.
3. Clean the grease adaptor and fitting and then lower the raised track to the ground.
4. Repeat Steps 1 to 3 for the other track.

**IMPORTANT:** If the grease fitting adaptor is damaged, grease may leak out. Check the condition of the grease fitting adaptor regularly and replace it if necessary.



7

## REPLACING A BACKHOE BUCKET

### REMOVAL

1. Place the bucket flat on flat, horizontal ground. Operate the attachment controls so that the dipper/bucket linkage pin is not gripped by the weight of the dipper.
2. Stop the engine and remove the starter switch key.
3. Remove the pins hardware.

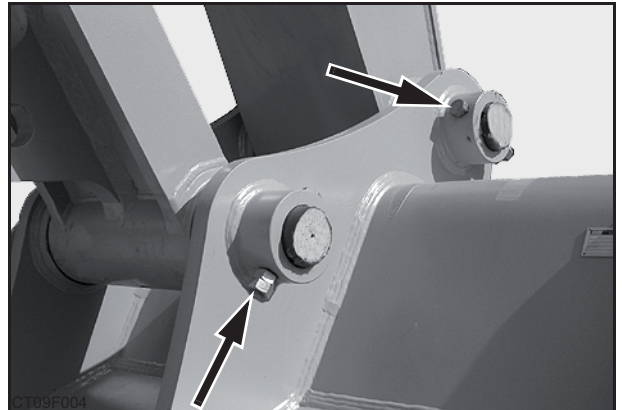

25

4. Remove the bucket pins.
5. Start the engine, disengage the attachment from the bucket and save the linkage seals for re-use.

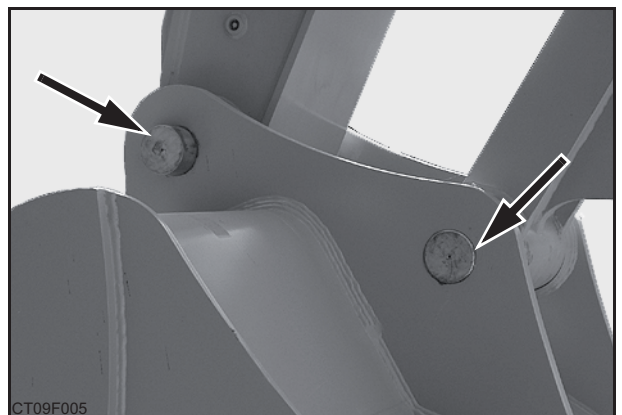

26

### INSTALLATION

1. Make sure the bucket is in a stable position.
2. Start the engine. Bring the dipper into its housing. Stop the engine and remove the starter switch key.
3. Install the linkage seals between the dipper and the bucket. Change them if necessary.

## SECTION 8 - MAINTENANCE/ADJUSTMENTS

### HARDWARE TORQUE INSPECTION

#### MAINTENANCE SPECIFICATION

Check ..... Every 250 hours  
(after the first 50 hours during the run-in period)

At the end of each working day, check all mounting nuts and screws for tightness and tighten if necessary. Make sure no hardware items are missing. Replace them, if necessary.

#### TORQUE SPECIFICATIONS PER COMPONENT

Component	Screw (Ø)	Wrench (mm)	Torque setting (Nm)
Travel reduction gear (*)	M24	36	900-1051
Drive sprocket (*)	M20	30	521-608
Idler wheel (*)	M16	24	267-312
Upper roller (*)	M20	30	521-608
Lower roller (*)	M20	30	521-608
Chain guide (*)	M20	30	521-608
Track pad	M20	30	813-911
Counterweight	M33	50	1548-1764
Turntable (undercarriage)	M24	36	784-914
Turntable (upperstructure)	M24	36	784-914
Swing reduction gear (*)	M24	36	784-914
Engine (*)	M20	30	289-337
Engine mounts (*)	M10/M12	17/19	64-74/109-127
Radiator	M16	24	147-177
Hydraulic pump (*)	M10 M20	17 hexagonal	64-73 367-496
Hydraulic reservoir (*)	M16	24	232-276
Fuel tank (*)	M16	24	232-276
Control valve	M16	24	267-312
Hydraulic swivel (*)	M12/M16	19/24	109-127/267-312
Cab	M16	24	157
Batteries	M10	17	16-20

**NOTE:** Use Loctite 262, or the equivalent, on screws marked (\*).

## SECTION 9 - ELECTRICAL SYSTEM

3. Pull the clip outwards, remove the bulb and install a bulb of the same wattage (70 W).

**IMPORTANT:** Never put your fingers on a tungsten iodide bulb.

4. Install the clip and reconnect the plug.
5. Put the working light back into position and install the mounting screws.

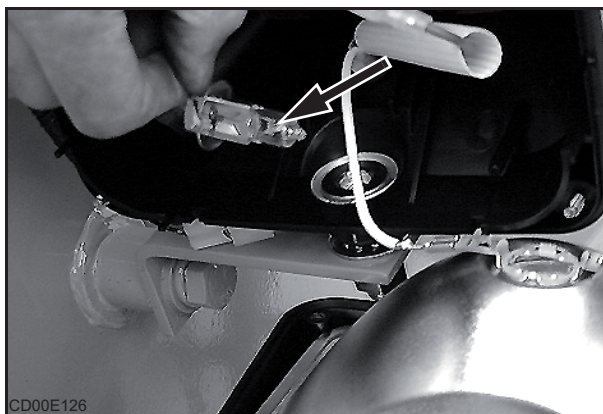

14

### UPPERSTRUCTURE AND CAB HEADLIGHT

1. Open the front box.



15

2. Remove the switch bracket to access the head-lamp.

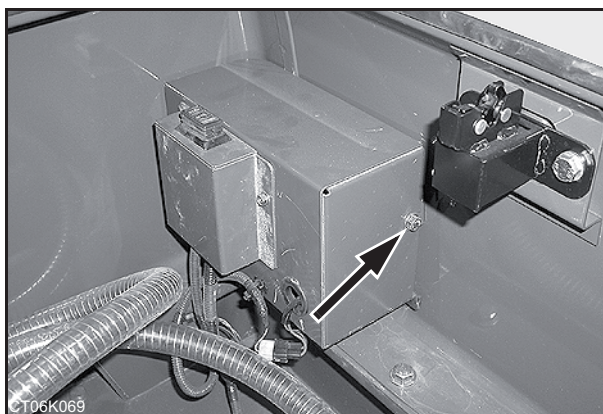

16

SECTION 11 - SPECIFICATIONS

(NLC type)

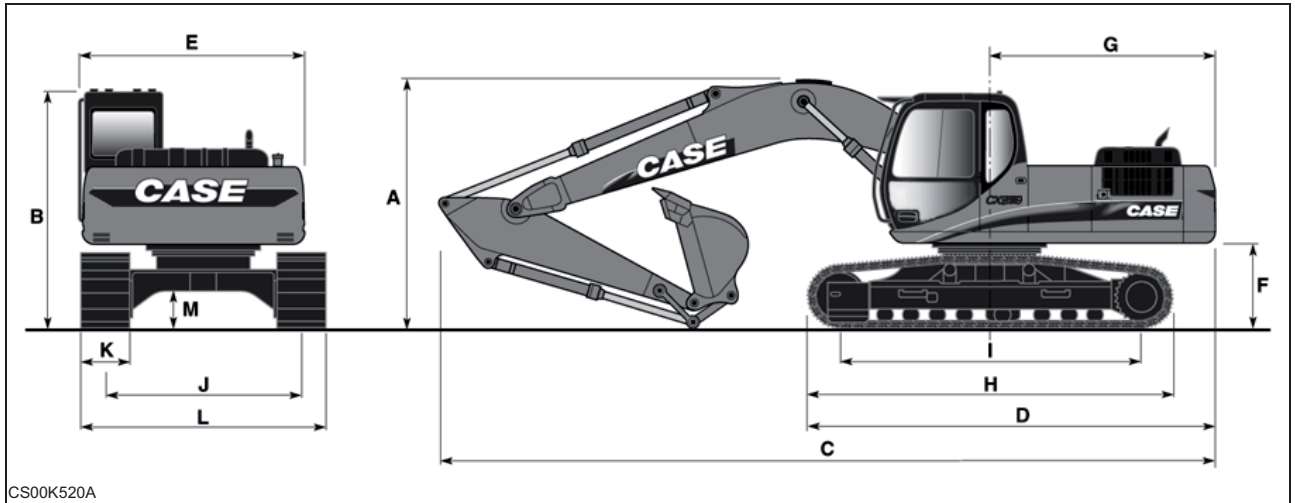

CS00K520A

	2		
Dippers	2.65 m	3.20 m	3.60 m
(A).....	3.34 m	3.26 m	3.46 m
(B).....	3.08 m	3.08 m	3.08 m
(C).....	10.48 m	10.45 m	10.47 m
(D).....	5.58 m	5.58 m	5.58 m
(E).....	2.87 m	2.87 m	2.87 m
(F).....	1.19 m	1.19 m	1.19 m
(G).....	3.15 m	3.15 m	3.15 m
(H).....	4.85 m	4.85 m	4.85 m
(I).....	3.98 m	3.98 m	3.98 m
(J).....	2.39 m	2.39 m	2.39 m
(K) (standard track pads).....	0.60 m	0.60 m	0.60 m
(L) (with 600 mm track pads).....	2.99 m	2.99 m	2.99 m
(L) (with 700 mm track pads).....	3.09 m	3.09 m	3.09 m
(M).....	0.47 m	0.47 m	0.47 m
(N).....	3.11 m	3.11 m	3.11 m

CLICK HERE TO **DOWNLOAD** THE COMPLETE MANUAL

- Thank you very much for reading the preview of the manual.
- You can download the complete manual from: [www.heydownloads.com](http://www.heydownloads.com) by clicking the link below



- Please note: If there is no response to CLICKING the link, please download this PDF first and then click on it.

CLICK HERE TO **DOWNLOAD** THE COMPLETE MANUAL