

ORIGINAL INSTRUCTIONS

CX240C-8
CX260C-8
CX260C-8 Long Reach
Crawler Excavator

OPERATOR'S MANUAL

Part number 51548740
1st edition English
October 2018



CLICK HERE TO **DOWNLOAD** THE COMPLETE MANUAL

- Thank you very much for reading the preview of the manual.
- You can download the complete manual from: www.heydownloads.com by clicking the link below



- Please note: If there is no response to CLICKING the link, please download this PDF first and then click on it.

CLICK HERE TO **DOWNLOAD** THE COMPLETE MANUAL

Product identification

The CX240C-8 — CX260C-8 is a crawler hydraulic excavator. It consists of an undercarriage fitted with tracks and a turntable bearing which supports the upperstructure frame. The upperstructure frame supports the attachment, at the front end of the machine, plus the engine, hydraulics and cab. When the operator works the controls, the engine-driven pump delivers hydraulic fluid to the control valves. The control valves distribute the hydraulic fluid to the various cylinders and hydraulic motors employed. A cooling system maintains the hydraulic fluid at normal operating temperature.

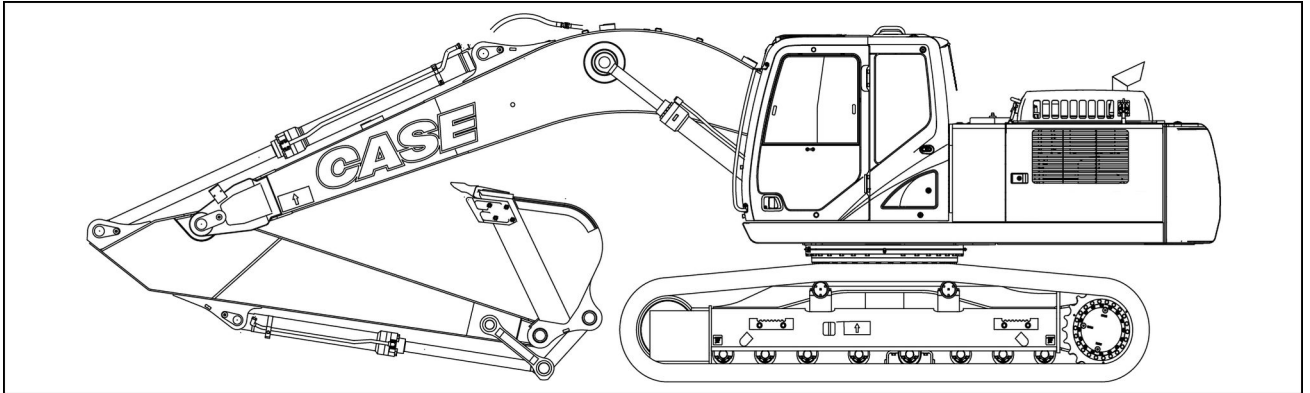

SMIL18CEX1669EA 1

CX240C-8 — CX260C-8

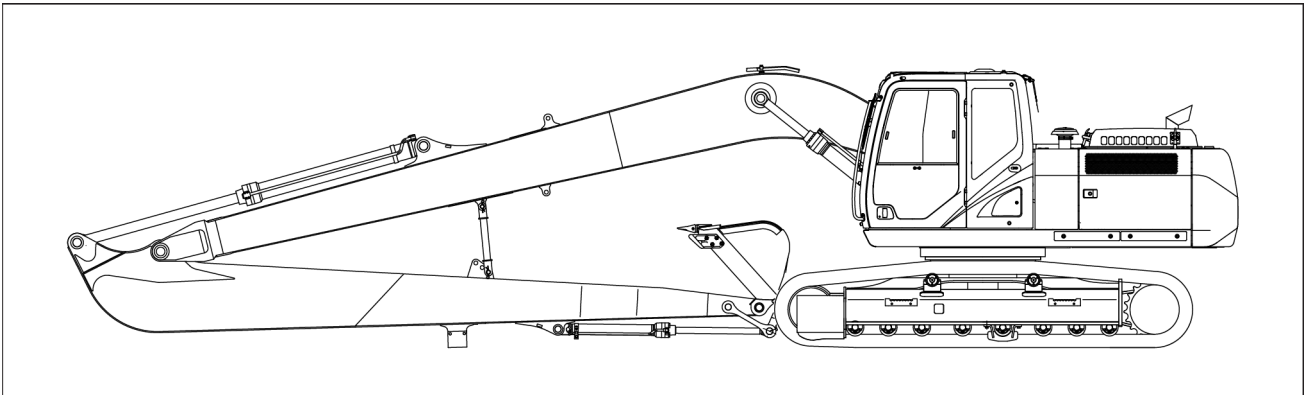

SMIL18CEX0555EA 2

CX260C-8 LR (Long Reach)

When ordering parts, obtaining information or assistance, always supply your CASE CONSTRUCTION Dealer with the type and serial number of your machine or accessories. Write the following in the spaces below: the type, serial number and year of manufacture of your machine, accessories and the serial numbers of the various hydraulic and mechanical components.

Machine

(1) Designation/Model

Hydraulic Excavator CX240C-8 — CX260C-8

(2) Product Identification Number (PIN)



SMIL18CEX0806AA 3

- When alighting from or getting into the operator's compartment, always face the machine and use the steps and access handles.
- Be sure you know the position and function of each control. Incorrect operation of the controls can cause serious injuries.
- Check all controls and safety devices in a safe, open area before starting work.
- Keep away from dangerous areas such as ditches, overhangs, rocky areas, etc. Make a survey of the work-site and determine the possible dangers before using the machine.
- Before parking the machine, make sure that the ground is stable. Plan the worksite so that the ground is flat, hard and level.
- Before moving the machine to work in a new area, walk around to determine all possible causes of accidents there. Holes, obstacles, debris and other danger risks in the working area can cause serious injury.
- Be ready to meet emergencies. Always carry a first aid kit and if possible, fire extinguisher (not supplied) within easy reach on board. Make sure the fire extinguisher is regularly serviced in conformance with the manufacturer's instructions.
- Check the fastening of the main components: counterweight, turntable bearing and operator's compartment. In the event of problems, consult your CASE CONSTRUCTION Dealer.
- Make sure you understand the symbols used on the machine safety decals. Keep the decals clean so that they are perfectly legible at all times.
- Work out a means of convenient escape from the machine (emergency exit via the windshield or the rear window glass) in the event of the machine turning over or tipping over or the cab door being jammed.
- Make sure you are perfectly familiar with traffic regulations and special safety equipment requirements before transporting this machine on a public highway.
- When loading trucks, never swing the load over the truck cab.
- Before undertaking any travel on the job site, make sure the itinerary to be followed is completely safe. If bridges are to be crossed, make sure they are perfectly capable of supporting the weight of the machine.
- Always steer round large obstacles such as boulders, big trees, etc.

Quick coupler (optional)

- Every day, check that the locking bar functions correctly and that it is not fouled by foreign matter. Clean the locking system if necessary.
- If you are obliged to use the quick coupler with buckets not manufactured by CASE CONSTRUCTION, make sure the diameter of the pins and the width between the bucket lugs meet the dimensions needed to fit the quick coupler (pins, washers, bushings, etc.). Consult your CASE CONSTRUCTION Dealer.

Operating the machine

- When working on a public highway, use standard traffic signs and take into consideration the working range of the upperstructure and its attachments. Local or national regulations stipulate the number, type and location of reflector strips.
- Avoid running the engine in a confined space. If there is no alternative, proper ventilation must be provided at all times.
- Do not allow anyone else on the machine. The passenger could fall or cause an accident.
- Never operate the working or travel controls unless you are properly seated in the operator's seat with the seat belt correctly fastened.
- Before starting the engine, check the direction of travel (in forward drive, the reduction gears should be to the rear of the machine).
- Do not work near overhead high-voltage electric lines without checking beforehand that all necessary measures have been taken to respect the minimum distances:
Less than 57000 volts: **3 m (9.8 ft)**.
More than 57000 volts: **5 m (16.4 ft)**.
- Study the position of any existing pipelines or conduits before starting work. Electrical cables, gas and water pipes and other underground installations can cause serious injury.
- Always make allowance for working conditions (sloping or rough ground), the site and weather conditions when driving the machine.
- Do not allow anyone to stand in the machine working area. Accidental operation of the upperstructure swing control or of an attachment control could cause an accident. Stop all operations until everyone has moved away.
- Before operating the dozer blade (if equipped) make sure that there is no one in the working area of the latter.
- Operate all controls gradually to ensure smooth machine operation.
- Whenever load handling operations are to be carried out, it is imperative to adhere strictly to the instructions given in this manual and local legislation.
- It is forbidden to use the machine to carry out tasks other than those for which it is intended. Never use the equipment for sweeping the ground to level out rubble or push objects (transversal stress on the attachment).
- Stop the engine and remove the ignition key when the machine is not in use, even for short periods of time.

Position of decals

When replacing a decal, make sure it is located as shown below.

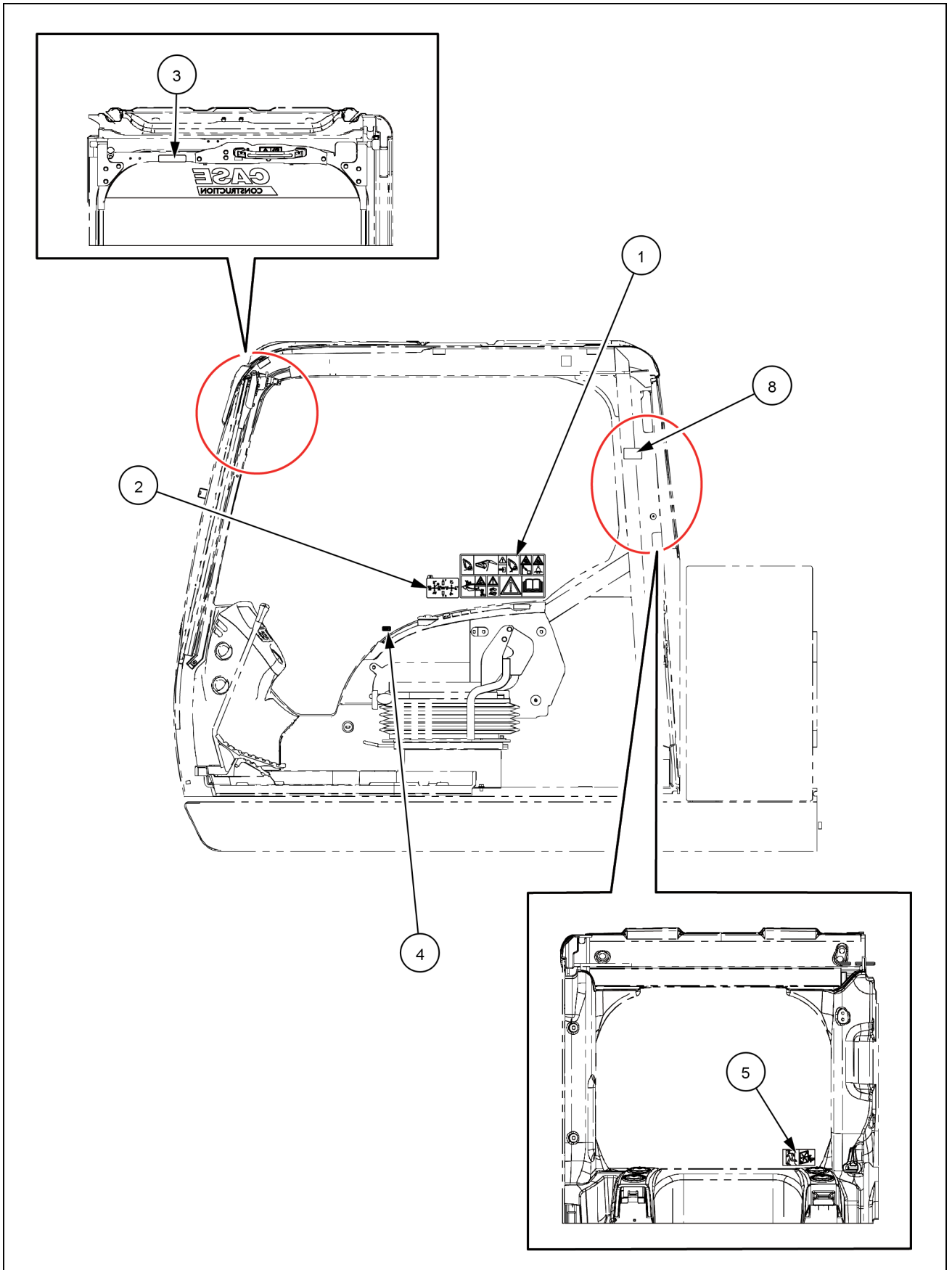

(25) Common rail high pressure decal

Part number: KHP13170

Common rail injection system contains fuel under extreme pressure that can cause fatal injuries. Do not open the common rail pump, or loosen the common rail high pressure lines, or touch any other component of the common rail injection system. Consult the CASE CONSTRUCTION dealer for service.

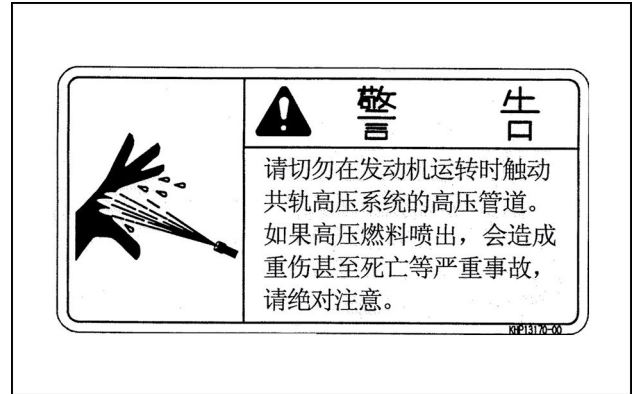

KHP13170 34

(26) Engine operation

Part number: KHP22400

Always stop and cool down the engine before making any maintenance operation in the engine compartment.

Do not step on the engine as this can cause serious damages to the engine components and serious injuries to the operator.

Make sure to read operator's manual to understand proper procedures for the engine maintenance.



KHP22400 35

(27) Fuel Line Valve

Part number: KHP29601

Thoroughly read and understand the operator's manual before starting inspection and service of the fuel system.

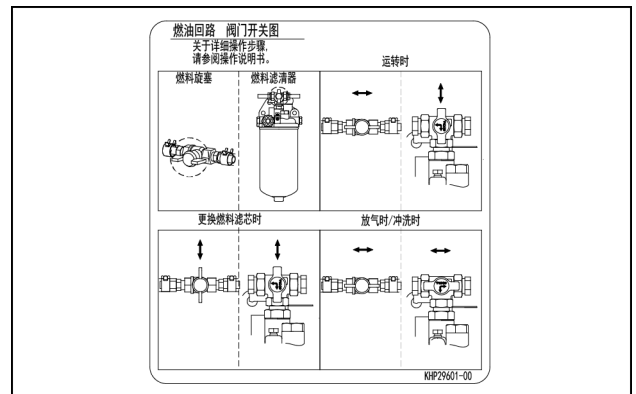

KHP29601 36

(28) Starting the engine

Part number: KHP1336

Do not try to start the engine by auxiliary tools. Machine may start to move suddenly and unintendedly causing serious injuries to the operator and to the bystanders.

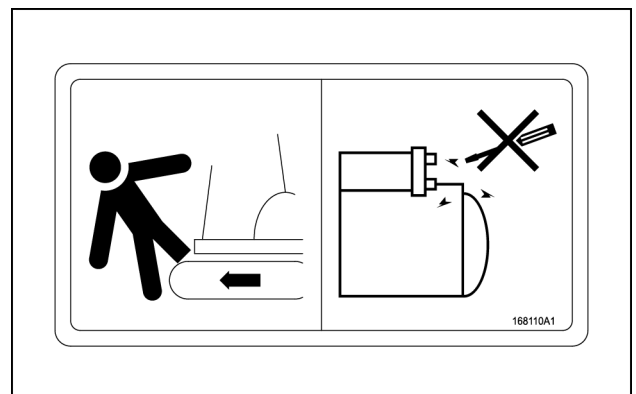

KHP1336 37

Windshield

⚠ CAUTION

Pinch hazard!

Make sure you correctly follow the instructions in this manual when handling the windshield. If you do not handle the windshield correctly, it could slip and injure your fingers or hands.

Failure to comply could result in minor or moderate injury.

C0045A

Opening

1. Fold the sun shield (1) back against the windshield and operate the lever (2). Hold the lower and upper handles (3) and carefully raise the windshield.

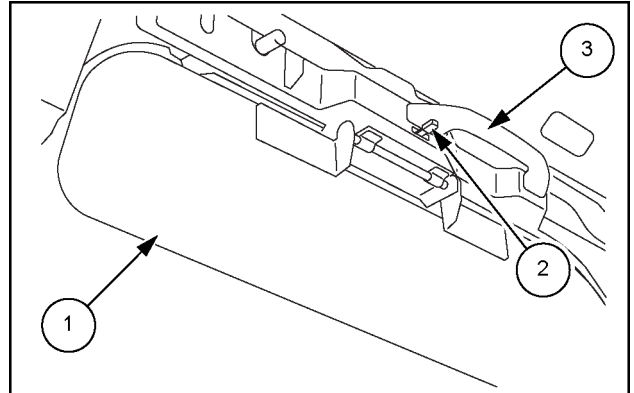

SMIL14CEX1684AB 1

2. Pull the windshield to the rear until it engages perfectly behind the cab.

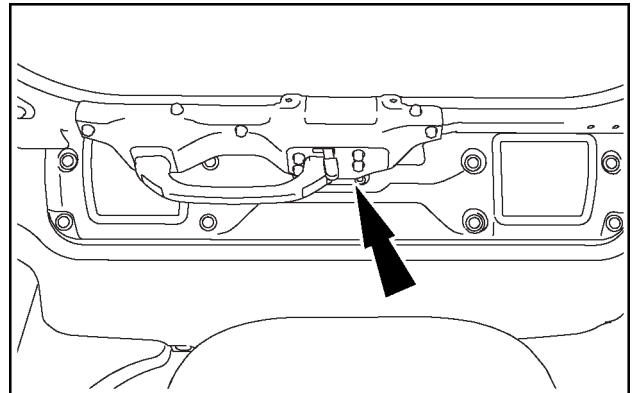

SMIL14CEX1685AA 2

Closing

1. Use the lever (2) to release the windshield.
2. Hold both handles (3) and carefully lower the windshield. Make sure the window is completely down.
3. Make sure the top of the windshield is correctly latched.

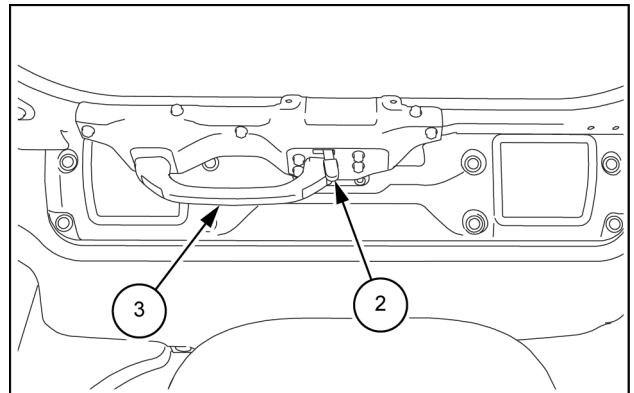

SMIL14CEX1686AB 3

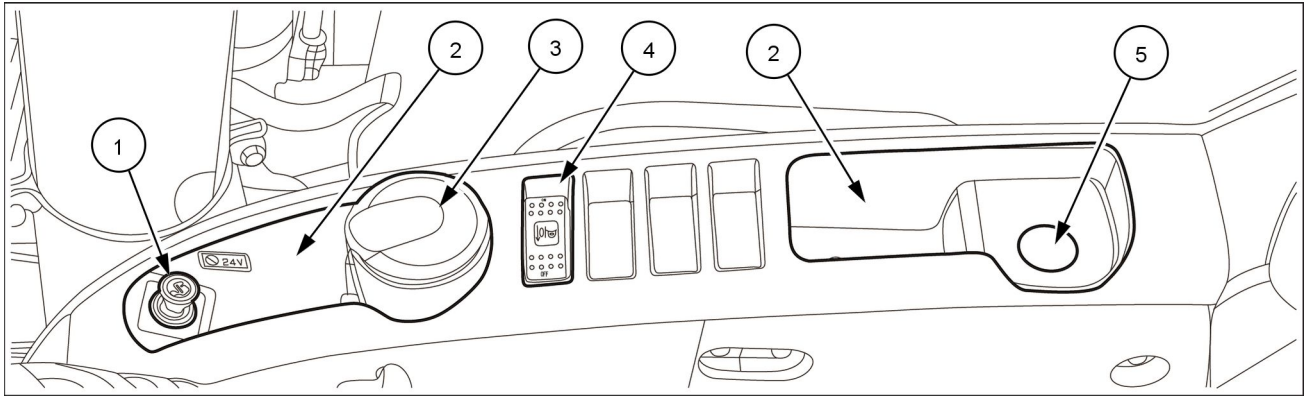

SMIL18CEX0527EA 2

(1) Cigarette lighter and 24 V power supply socket: the device is active with the starter key in ON position, or while the engine is running.

To operate the cigarette lighter, push it down to engage its heating position.

NOTICE: keep pushing the cigarette lighter can cause serious damages to the device and to the machine electrical system.

NOTICE: the electrical system may be damaged if the cigarette lighter does not return to its original position after 30 s. Pull it out manually and consult the CASE CONSTRUCTION dealer.

NOTICE: connect only 24 V devices to the socket. Connecting devices functioning at different voltage can cause damages to the device itself and to the electrical system.

(2) Storage tray.

(3) Ashtray.

(4) Horn volume lowering switch: the horn volume lowering switch allows to change the volume of the horn. Press the ON side of the switch to lower the volume of the horn. Press the OFF side of the switch to resume the normal volume of the horn.

(5) 12 V power supply socket: the device is active with the starter key in ON position, or while the engine is running.

NOTICE: connect only 12 V devices to the socket. Connecting devices functioning at different voltage can cause damages to the device itself and to the electrical system.

User information mode

Press the button **(1)** to access the user information mode of the display.

Press the button **(3)** as indicated into the next pictures in order to scroll down to the intended setting tab.



LANGUAGE setting

The first tab of the user information mode allows to set the language of the messages on the display.

Press the button **(1)** or **(2)** to select the desired language.

If other settings are needed, press the button **(3)** to scroll down to the next tab.

Otherwise, press the button **(4)** to confirm the selection and to reset the operating mode of the display.

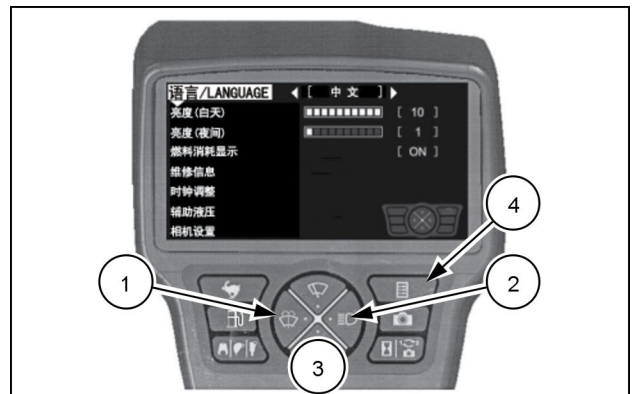

BRIGHTNESS (DAY) setting

The second tab of the user information mode allows to set the brightness of the display in daylight.

Press the button **(2)** to increase the brightness of the display, press the button **(1)** to decrease the brightness of the display.

If other settings are needed, press the button **(3)** to scroll down to the next tab.

Otherwise, press the button **(4)** to confirm the selection and to reset the operating mode of the display.

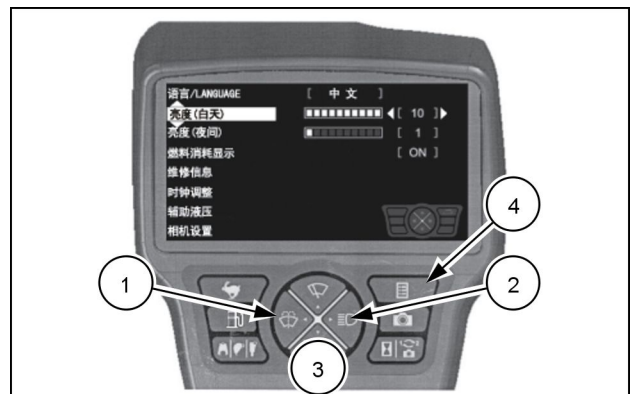

BRIGHTNESS (NIGHT) setting

The third tab of the user information mode allows to set the brightness of the display in low ambient lighting.

Press the button **(1)** or **(2)** to set the brightness of the display as described in the previous tab.

If other settings are needed, press the button **(3)** to scroll down to the next tab.

Otherwise, press the button **(4)** to confirm the selection and to reset the operating mode of the display.

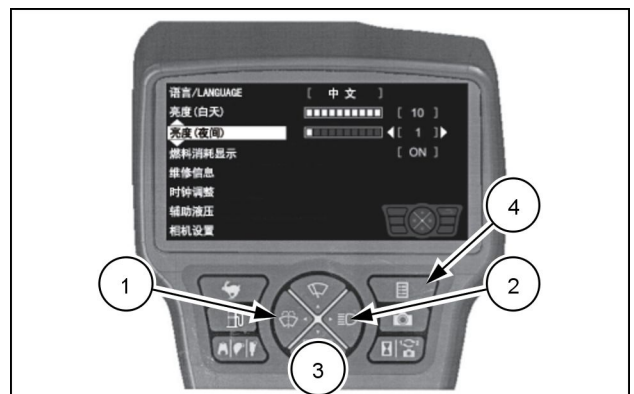

Rearward controls

Fuse box

Located on the left-hand side, behind the operator's seat. The fuse box can be readily accessed by opening the protective cover.

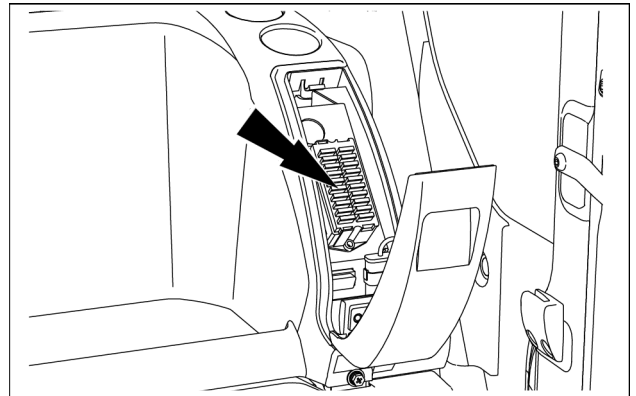

SMIL18CEX0781AA 1

Magazine rack

Located on the right-hand side, behind the operator's seat.

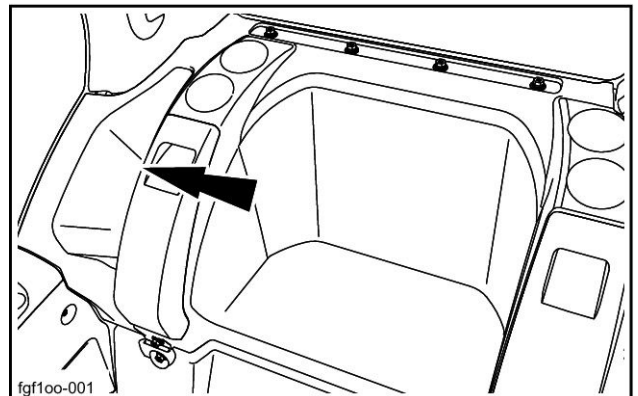

fgf100-001

FGF100-001A 1

Refrigerated/heated compartment

Located on the right-hand side, behind the operator's seat.

This compartment, associated with the air conditioning system, is designed to store different cold or hot products, drinks, etc.

NOTE: This is an insulated compartment. The compartment may not cool or heat depending on the conditions.

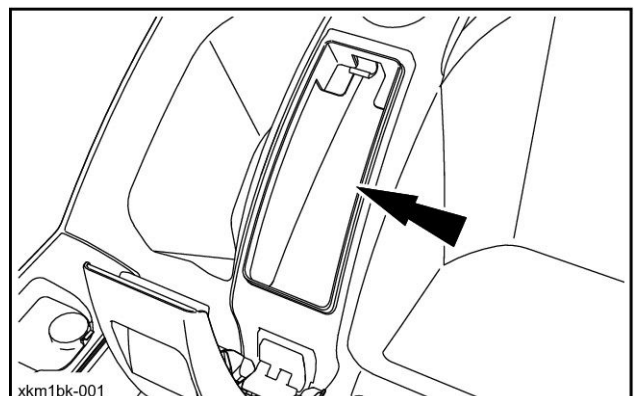

xkm1bk-001

XKM1BK-001A 1

Front storage box

⚠ WARNING

Moving parts!

**Make sure the storage box cover is closed properly before driving the machine.
Failure to comply could result in death or serious injury.**

W0288A

The storage box is located in the right front of the upper-structure. It is intended for storage of emergency tools and of small spare parts. The storage box also gives access to the fuel tank filler pump (if equipped) and to the right-hand working light.

Unlock the pushrod of the box cover with the starter key, and press the pushrod to open the box.

NOTE: The box cover is fitted with a gas strut, and the opening movement shall thus be followed through by hand in order not to damage the machine.

Pull down the cover to close the box, and lock the pushrod of the box cover with the starter key.

NOTICE: Make sure to close and lock the box before starting machine operation. Leaving the box open can cause serious damages to the machine, and may cause serious injuries to the bystanders.

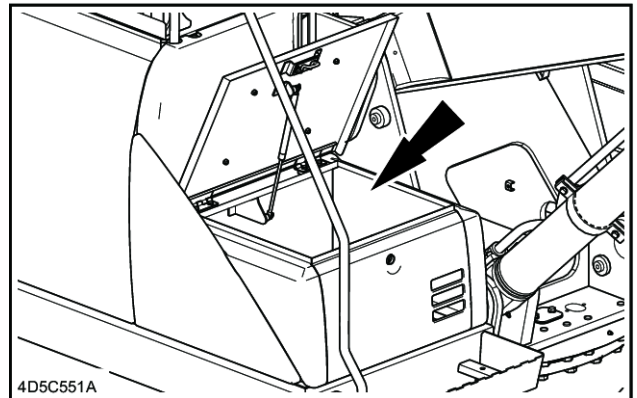

4D5C551A 1

Fire extinguisher

It is strongly recommended to have a fire extinguisher available and to keep it inside the front storage box.

Service specifications:

Every month: examine the fire extinguisher and make sure it is not damaged.

Every six months: have an approved specialist empty and refill the powder in the fire extinguisher.

Every year: have an approved specialist examine the fire extinguisher.

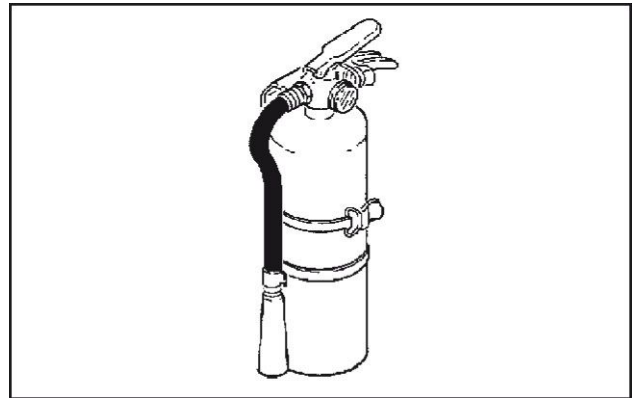

CS98M573TBP1 1

Operating the machine in hot or cold weather

In cold weather

- Make sure to use fluids and lubricants which have specifications suitable for operation at low ambient temperatures.
- Check the batteries for full charge state.
- Fill up the fuel tank after completing the work, and then drain water before starting work on the next day in order to prevent dew condensation and invasion of water to the fuel system.
- Use fuel which is rated to the outside air temperature, or proper anti-freeze in order to prevent crystal generation at **-2 °C (28 °F)**.

NOTICE: Before transporting the machine to a cold region, fill the tank with fuel that has a low freezing temperature.

In hot weather

- Make sure to use fluids and lubricants which have specifications suitable for operation at high ambient temperatures.
- Keep the coolant at the correct level in the coolant reservoir and in the radiator.
- Use the correct solution of ethylene glycol and water in the cooling system.
- Test the radiator cap before hot weather starts. Replace the cap as required.
- Clean all dirt and debris from the radiator, cooler and engine area.
- Check the condition of the fan drive belt.

Operation under dusty and sandy conditions

- Frequently inspect the element of the air cleaner and clean or replace the element and the dust cup regardless of service due.
- Tightly close the breather cap of the hydraulic tank to prevent invasion of sand and dust to the hydraulic circuits.
- Make sure to thoroughly clean the grease fittings before greasing any lubrication point of each pin and bush.
- Make sure to clean the radiator fin and oil cooler fin and the radiator grid.

Operation on seashore

- Inspect tightness of the plugs/cocks/bolts in each point in order to prevent salt corrosion.
- Thoroughly wash the machine after the work, especially take good care of the electrical equipment and hydraulic cylinder to prevent corrosion.

Operation on highly humid land or soft land

- Keep the machine as dry as possible during operation and make sure to carry out regular lubrication. Moisture and mud water cause deterioration and corrosion of paints/wirings/metal components.

Straight line travel (forward travel)

Press the two pedals (or push the two levers) forward at the same time.

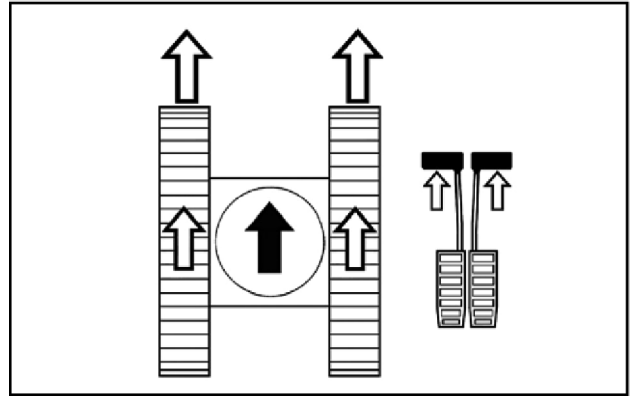

SMIL13CEX2679AB 2

Straight line travel (reverse travel)

Press the two pedals (or pull the two levers) rearwards at the same time.

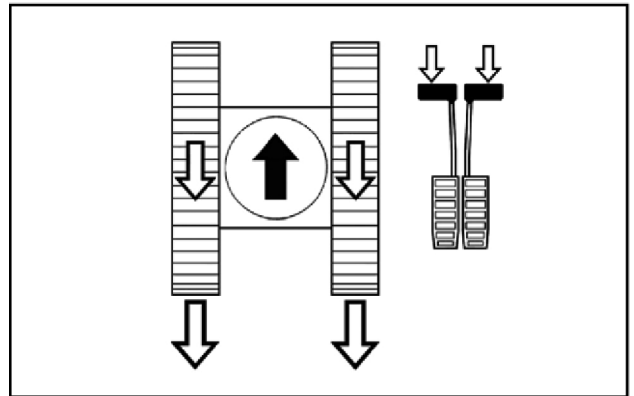

SMIL13CEX2680AB 3

Turning to the left (forward travel)

Simply press the right-hand pedal or push the right-hand lever forwards.

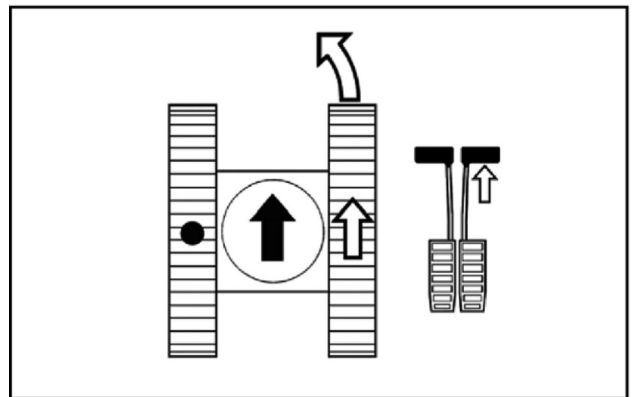

SMIL13CEX2681AB 4

Turning to the right (forward travel)

Simply press the left-hand pedal or push the left-hand lever forwards.

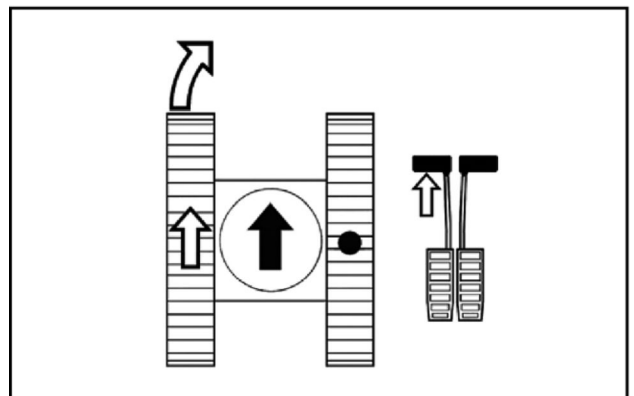

SMIL13CEX2682AB 5

CLICK HERE TO **DOWNLOAD** THE COMPLETE MANUAL

- Thank you very much for reading the preview of the manual.
- You can download the complete manual from: www.heydownloads.com by clicking the link below



- Please note: If there is no response to CLICKING the link, please download this PDF first and then click on it.

CLICK HERE TO **DOWNLOAD** THE COMPLETE MANUAL

Tie downs for shipping

1. Set the machine in the position for transport: fully retract the arm and curl the bucket slowly.
2. Place the block **(B)** on the trailer floor and lower the boom slowly. Adjust the position of the block **(B)** so that the bucket linkage lays on the block **(B)**.
3. Check the overall height between the ground and the highest point of the machine and check the overall width of the machine. Make sure to be within the size limits defined before transport, in order to confirm documents and permissions already got to comply to the local traffic regulations.
4. Place the gate lock lever in central position. Stop the engine and remove the starter key.
5. Get off the machine. Retract the radio antenna. Fold the rear view mirrors.
6. Lock the cab door and the side panels.
7. Check the condition of the tie-down points on the trailer.
8. Secure the machine onto the trailer using chocks **(C)**, chains, wire ropes **(A)** to prevent the machine from swaying (oscillation) during transport.
9. Carry out a final check of the tie-down condition.
10. If a rear loading type trailer is used for road transport, lift or remove the loading ramps.
11. Remove blocks from the tires of the trailer.

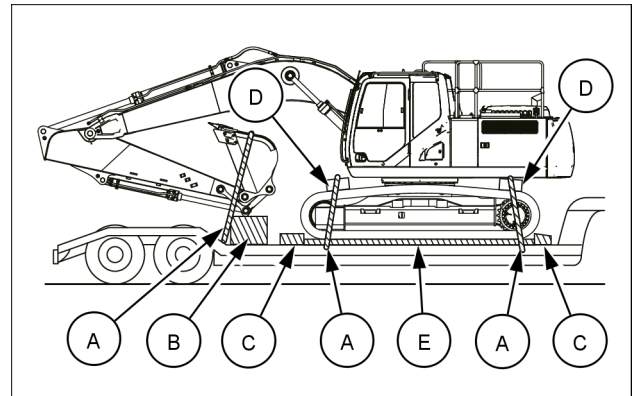

SMIL18CEX0502AA 1

- (A)** Wire rope
- (B)** Block
- (C)** Chock
- (D)** Padding
- (E)** Rubber mat

Engine coolant

CASE AKCELA ACTIFULL™ OT EXTENDED LIFE COOLANT is the reference genuine product for machine service.

NOTICE: *Never add Supplemental Coolant Additives (SCA) when using CASE AKCELA ACTIFULL™ OT EXTENDED LIFE COOLANT.*

CASE AKCELA ACTIFULL™ OT EXTENDED LIFE COOLANT has to be used if refilling of the cooling system is needed. Refer to the dedicated procedure and recommendations described in Chapter 6.

CASE AKCELA ACTIFULL™ OT EXTENDED LIFE COOLANT shall be used for the replacement of engine coolant according to the maintenance program of the machine. The replacement shall also be tackled in case of repair or replacement of components of the cooling system. Refer to the dedicated procedure described in Chapter 6.

The engine cooling system shall always be refilled with coolant solution made by mixture of antifreeze and distilled (deionized) water.

NOTICE: *Never refill the cooling system with only antifreeze. Never refill the cooling system with only water.*

Using **CASE AKCELA ACTIFULL™ OT EXTENDED LIFE COOLANT**, a 50/50 mixture of antifreeze and distilled (deionized) water grants proper performance of the engine cooling system in the above mentioned operating temperature range of the machine.

CASE AKCELA ACTIFULL™ OT EXTENDED LIFE COOLANT is available as:

- 50/50 PREMIXED coolant solution ready for usage.
- CONCENTRATE antifreeze to be mixed 50/50 with distilled (deionized) water.

NOTICE: *If operating in extreme winter climate, a coolant solution made by 60/40 antifreeze/distilled (deionized) water mixture shall be used in order to grant proper performance of the engine cooling system.*

NOTICE: *Never use coolant solution with more than 60% of antifreeze. This affects the cooling capacity of the mixture.*

When the coolant solution is prepared starting from the CONCENTRATE product, the antifreeze concentration in the mixture of antifreeze and distilled (deionized) water can be determined with a refractometer designed to measure ethylene glycol content.

If distilled (deionized) water is not available, use water for dilution with the following properties:

Property	Maximum limit
Total Solids	340 ppm
Total Hardness	170 ppm
Chloride (Cl)	40 ppm
Sulfate (SO ₄)	100 ppm
Acidity pH	5.5 to 9.0

NOTICE: *Never use hard water, sea water and softened sea water that has been conditioned with salt. The minerals and salts present in potable water can cause corrosion and deposits resulting in shortened engine life.*

Break-in period

Grease points (Bucket)

Lubricate the bucket linkage every **10 h** within the first **50 h**: to lubricate the bucket linkage refer to page **6-23**.

Cab protection system

Check the cab protections after **50 h**: To check the cab protections refer to page **6-39**.

Tightening torques

Check the tightening torques after **50 h**: To check the tightening torques refer to table on page **6-37**.

Track shoe bolt torque

Check the tracks shoes bolts torque after **50 h**: To check the tightening torques refer to table on page **6-38**.

Hydraulic oil return filter

Replace the hydraulic return filter after **250 h**: To replace the hydraulic return filter perform the operations described on page **6-60**.

Pilot line filter

Replace the pilot filter after **250 h**: To replace the pilot filter perform the operations described on page **6-61**.

Swing reduction unit oil

Replace the swing reduction gear oil after **250 h**: To replace the swing reduction gear oil perform the operations described on page **6-56**.

Travel reduction units oil

Replace the travel reduction gear oil after **250 h**: To replace the travel reduction gear oil perform the operations described on page **6-57**.

Swing reduction unit oil

⚠ WARNING

Hot surface possible!

Wait for all components to cool before performing any operation.

Failure to comply could result in death or serious injury.

W0251A

Check the swing reduction gear oil level every **250 h**.

Lubricant: **CASE AKCELA GEAR LUBE 135 H EP 80W-90**

1. Park the machine on a flat and level place. Stop the engine, and remove the starter key.
2. Remove the oil gauge **(1)**, clean it with a neat cloth, and check the oil level. Oil needs to reach the hatched area.
If necessary, supply oil via the filler neck **(2)**, and check the oil level again.
3. Attach the oil gauge **(1)**.

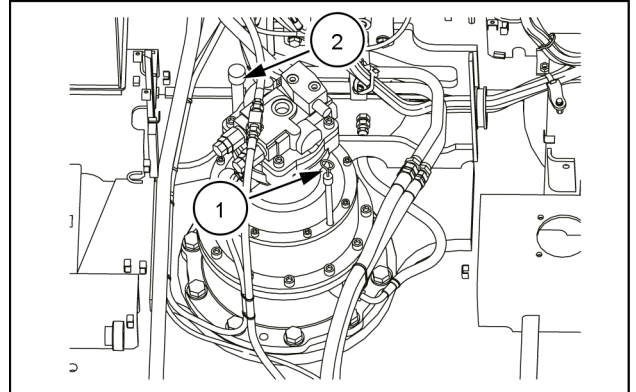

SMIL14CEX2799AB 1

Fan and alternator drive belt

Check the belt tension every **250 h**.

Inspection of tension

NOTICE: Operating the engine with loosened belt may cause over heat of the engine or insufficient charging of the battery due to slipping belt in its housing.

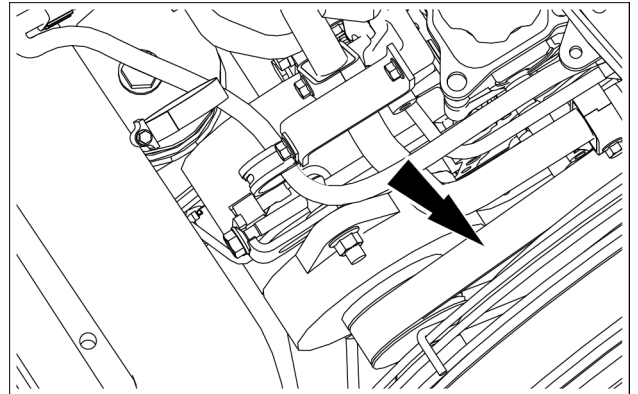

SMIL17CEX4725AA 1

Apply finger pressure of about **10 kg (22.0 lb)** center of the belt while the engine is shut down and the starter key is removed.

Loose of tension should be about **6 – 8 mm (0.236 – 0.315 in)**.

NOTE: Check any indication of damage on the pulley or belt due to wear. Check thoroughly to make sure that the belt is correctly engaged to groove of the pulley. The belt must be replaced if it is elongated, it has cracks or it is worn out.

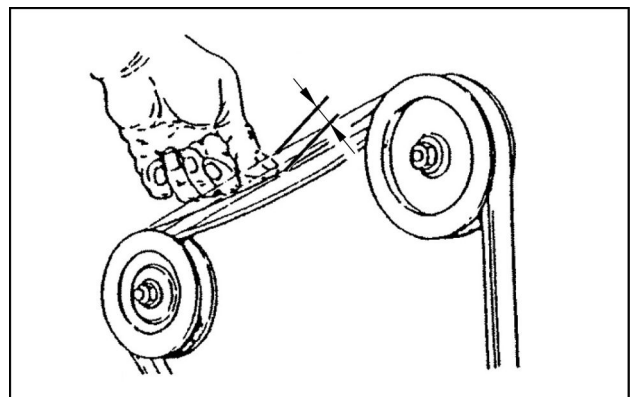

SMIL14CEX2789AA 2

Adjustment of tension

1. Loosen the lock nut **(1)** and the mounting bolt **(2)**.
2. Lightly tighten the lock nut **(1)** until its seating face touches.
3. Rotate the adjust bolt **(3)** to adjust tension of the belt to become standard value.
4. Tighten the lock nut **(1)** and the mounting bolt **(2)** that have been loosened with specified torque.
Tightening torque of the mounting bolt **(2)**:
126.5 N·m (93.302 lb ft)
Tightening torque of the lock nut **(1)**:
75.5 N·m (55.686 lb ft)

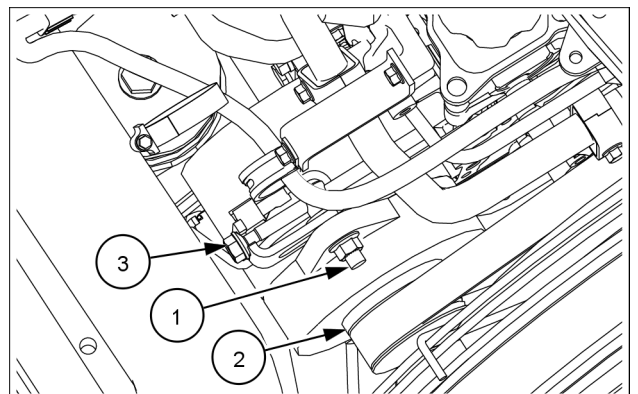

SMIL17CEX4725AA 3

Radiator and coolers

⚠ WARNING

Flying debris!

Compressed air can propel dirt, rust, etc. into the air. Wear eye and face protection when using compressed air.

Failure to comply could result in death or serious injury.

W0307A

Clean the radiator every **500 h**

1. Stop the engine, and remove the starter key.
2. Fully open the rear left-hand door until the door is fixed by the stay.
3. Release the latches and raise the engine hood until the hood is fixed by the stay.

NOTICE: always check that the door and the hood are fixed firmly.

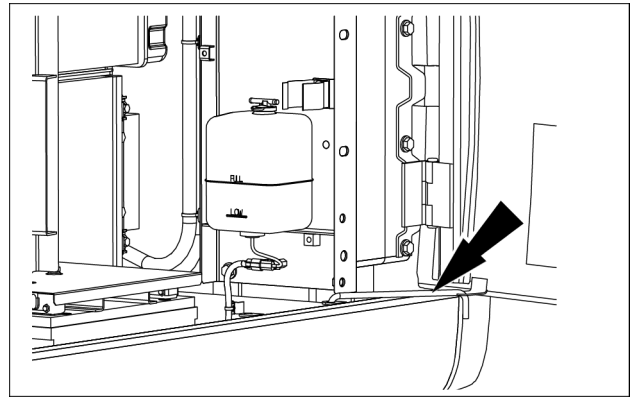

SMIL17CEX4729AA 1

4. Remove the quick-connect clips **(1)**, and pull the anti-dust net while holding its handle.
5. Lower the anti-dust net **(2)** to remove it.
6. The anti-dust nets are split. Remove the upper net first. Next, remove the quick-connect clips **(1)** from the lower anti-dust net, and pull it while holding its handle.
7. Raise the anti-dust net **(2)** to remove it.

NOTICE: *overheat may occur if the protection net, the radiator fin, or the oil cooler fin is clogged.*

8. Use compressed air to blow away mud or dirt that have clogged the net and fin. Steam or compressed water may be used instead of compressed air.

NOTICE: *Apply high-pressure vehicle-wash steam from a sufficient distance away. If the steam outlet is too close, the radiator fin may deform.*

NOTICE: *In presence of greasy or oily dust, use perchlorethylene. Use of trichloroethylene is strictly forbidden.*

9. Attach the lower anti-dust net, and then attach the upper anti-dust net. During attachment, check that the anti-dust nets are firmly fit on the guide rail.
10. Fix the anti-dust nets with the quick-connect clips.

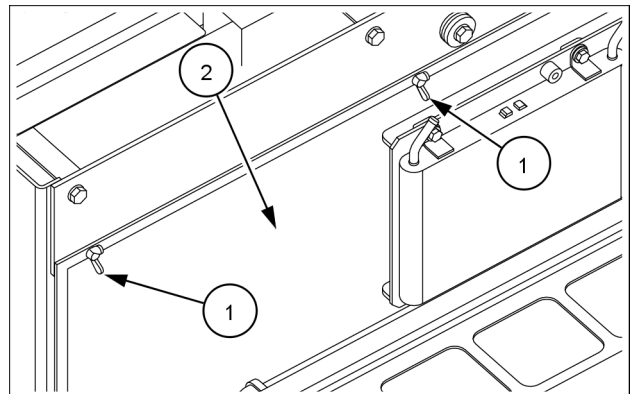

SMIL17CEX4730AA 2

Hydraulic fluid analysis

Check the hydraulic oil condition every **1000 h**

NOTICE: *When using the hydraulic breaker, reduce the interval of the hydraulic oil analysis. Refer to Chapter 9.*

Ask your CASE CONSTRUCTION Dealer to analyze the hydraulic oil condition.

Engine valve rocker clearance adjustment

Check the clearance of the engine valve rocker every **1000 h**

Ask your CASE CONSTRUCTION Dealer to check the engine valve rocker clearance.

Flushing the engine cooling system

9. Inspect and clean the radiator cap. Inspect hoses and clamps of the engine cooling system. Make sure to replace any damaged parts.
10. Fill the radiator with tap water up to the edge of the coolant inlet.
11. Close the radiator cap.

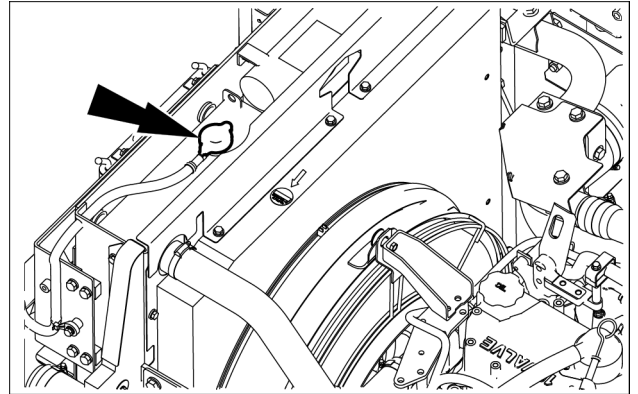

SMIL17CEX4742AA 5

12. Fill the reserve tank with tap water up to the FULL mark. Close the cap of the reserve tank.

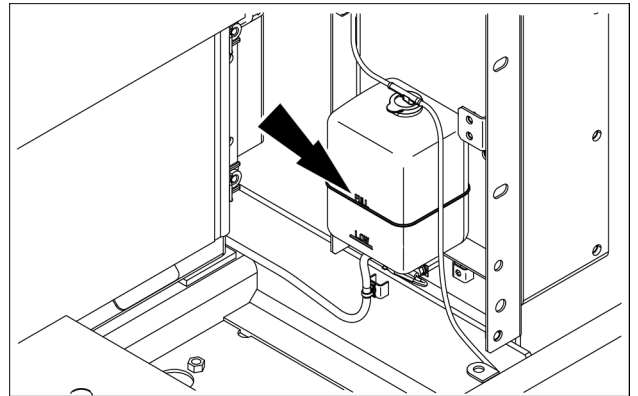

SMIL17CEX4708AA 6

13. Snug tighten the air bleed plug (1) on the EGR cooler when tap water overflows from it.
14. Start the engine and let it run at low idle speed for **20 min**. Turn on the cab heating system, and set the temperature and the fan speed to intermediate level.
15. Stop the engine. Wait until the engine has cooled down. Check for leakages from the hoses of the engine cooling system.
16. Drain water completely from the engine cooling system. Repeat the flushing procedure (steps from 10 to 15) for 2 more times. If drained water is still not clean, further repeat the flushing procedure until clean water is drained from the engine.

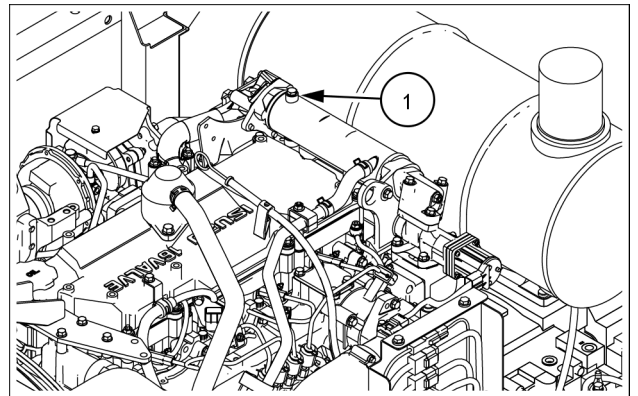

SMIL17CEX4745AA 7

⚠ WARNING

Pressurized fluid can penetrate the skin and cause severe injuries.

The grease in the cylinder is under high pressure. Never loosen the grease fitting adaptor completely in order to speed up the flow of grease.

Failure to comply could result in death or serious injury.

W0261A

To reduce the tension:

1. Turn the grease fitting adaptor about 3 times to loosen it and drain grease from the cylinder.
2. When the track tension is correct, tighten the adaptor.
3. Clean the grease adaptor and fitting, then lower the track to the ground.
4. Repeat the same operations for the other track.

NOTICE: if the grease fitting adaptor is damaged, grease may leak out. Check the condition of the grease fitting adaptor regularly and replace it if necessary.

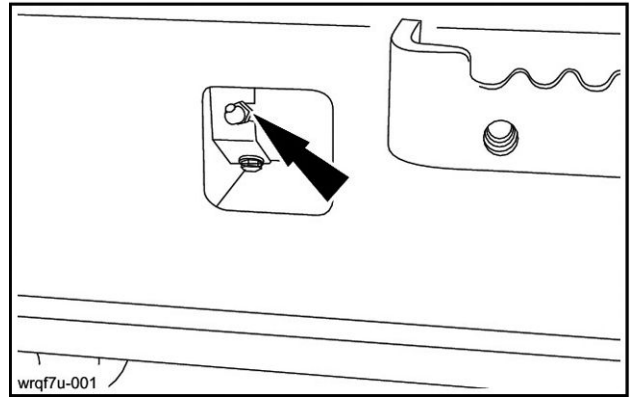

WRQF7U-001 7

Fuel tank strainer

Clean the fuel tank strainer periodically

Remove the fuel tank strainer, inspect it for damage. If damaged, discard and replace. If in good condition, clean it in an environmentally safe manner. Diesel fuel is a preferred cleaning agent. Fuel must not be added to the tank unless the strainer is in place and in good working condition.

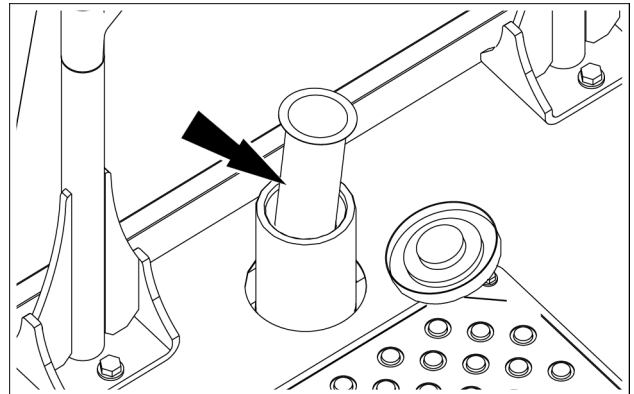

SMIL18CEX0514AA 1

Fuse and relay locations

Fuses

NOTE: Before changing fuses or relays, turn the ignition key to the "Shut down" position, wait one minute minimum and place the key of the battery master switch in "O" (Off) position (if equipped).

NOTICE: never replace a fuse with a fuse of a different amperage.

To access the fuse box, open the cover located behind the operator's seat.

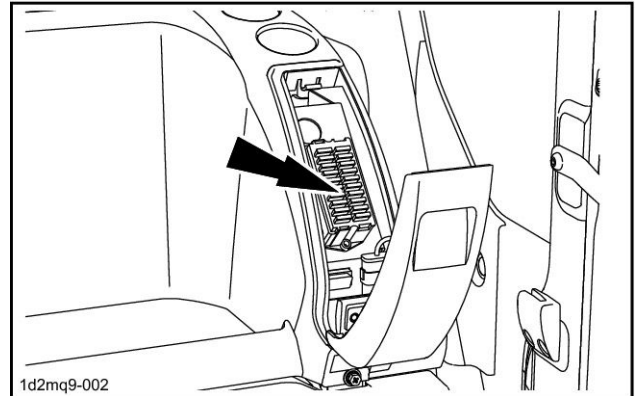

1D2MQ9-002A 1

To access the fuses, remove the cover on the box. A notice on the cover gives the function and amperage of each fuse.

NOTE: To remove or install a fuse, use the notch in the upper right-hand corner of the cover.

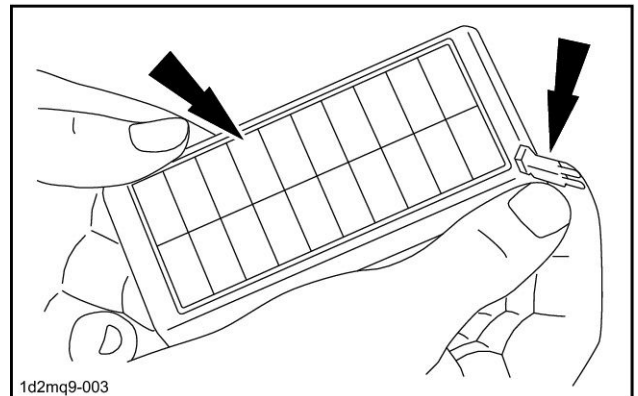

1D2MQ9-003A 2

Fluids and lubricants

By using appropriate fluids and lubricants the excavator can operate in ambient temperatures ranging from **-15 °C (5 °F)** to **45 °C (113 °F)**. Refer to the list of fluids and lubricants contained in this manual.

NOTICE: When operating the machine in ambient temperatures outside the above mentioned range, consult your **CASE CONSTRUCTION Dealer** for specific machine provision and for specific fluids and lubricants to be used.

	Quantity		CASE CON- STRUCTION specification	Reference specification
Fuel tank	410 L (108 US gal)	—	—	GB 252:2011
Engine oil	23.1 L (6.1 US gal)	CASE AKCELA NO. 1™ ENGINE OIL	MS 1121	SAE 15W40 API CI-4
Swing reduction unit	9.7 L (2.6 US gal)	CASE AKCELA GEAR LUBE 135 H EP 80W-90	MS 1316	SAE 80W/90 API GL-5
Travel reduction unit	5 L (1.3 US gal)	CASE AKCELA GEAR LUBE 135 H EP 80W-90	MS 1316	SAE 80W/90 API GL-5
Engine coolant	31 L (8.2 US gal)	CASE AKCELA ACTIFULL™ OT EXTENDED LIFE COOLANT CONCENTRATE (*)	MAT3624 Grade OAT-EG1	ASTM D6210 TYPE I-FF
		CASE AKCELA ACTIFULL™ OT EXTENDED LIFE COOLANT 50/50 PREMIXED	MAT3624 Grade OAT-EG2	ASTM D6210 TYPE III-FF
Hydraulic oil tank (**)	147 L (60.8 US gal)	CASE AKCELA HYDRAULIC LL 46	—	ISO 11158 L-HV46
Grease	—	CASE AKCELA 251H EP MULTI- PURPOSE GREASE	IH B-27 251H EP	NLGI 2

(*) Concentrate antifreeze to be mixed 50/50 with distilled (deionized) water.

(**) The total capacity of the hydraulic system is: **250 L (66.0 US gal)**

Working ranges CX260C-8 LR

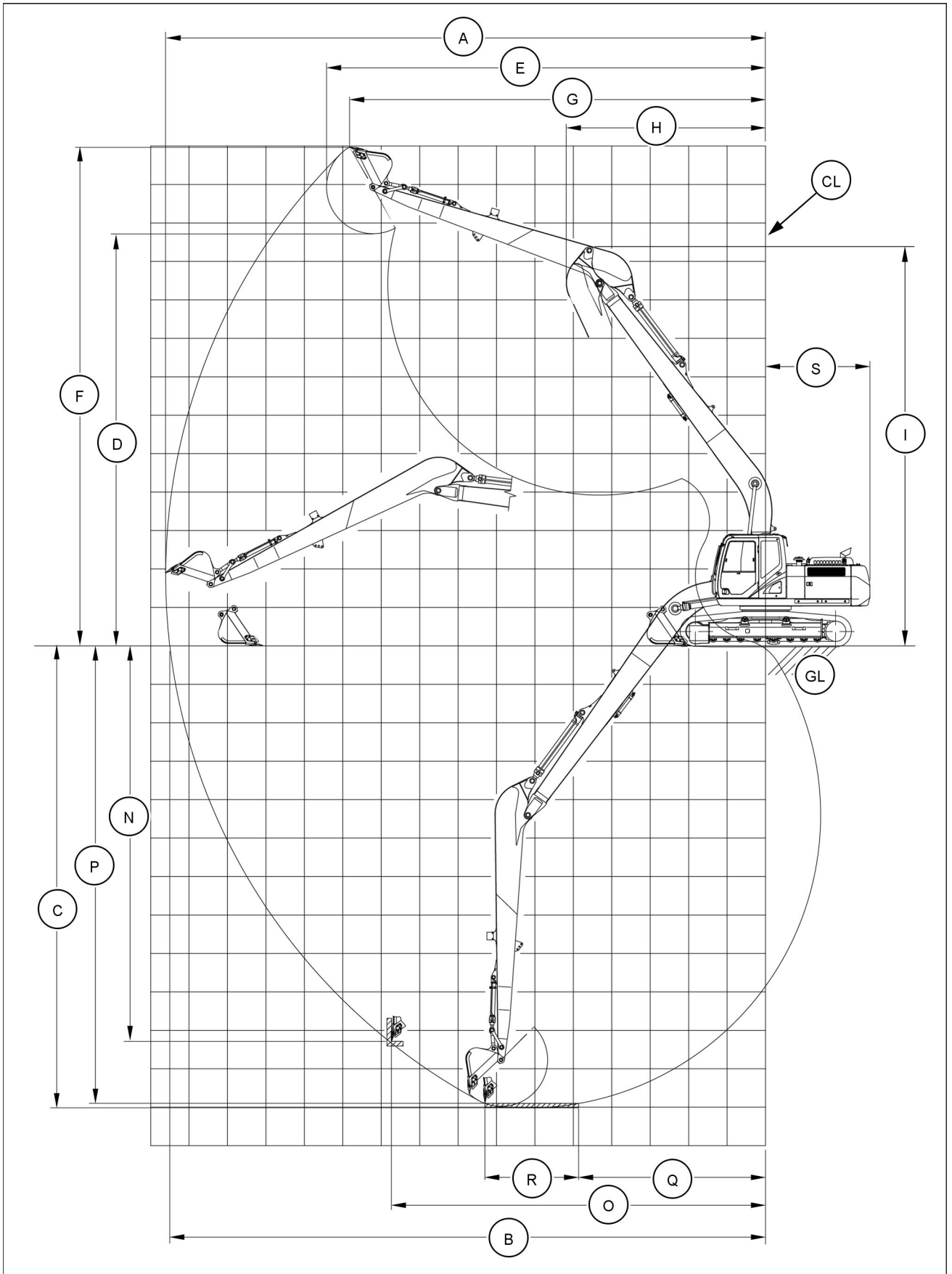

SML18CEX0765HA 6

Auxiliary low-flow hydraulic circuit

The machine can be equipped with an additional low-flow auxiliary hydraulic circuit to operate attachments featuring secondary hydraulic actuation for positioning, such as rotating grabs or tiltable buckets.

NOTE: the maximum flow rate of the auxiliary low-flow hydraulic circuit using the SP work mode is **66 L/min (17.4 US gpm)**. The maximum working pressure of the auxiliary low-flow hydraulic circuit is **20.6 MPa (2988 psi)**.

NOTE: an additional drainage line (**D**) is located on the left side of the arm. The drainage line (**D**) is intended to allow external drainage from an hydraulic motor.

NOTICE: always keep each connecting hose on the same side of the arm. Never cross-over the connecting hoses between the two sides of the arm.

NOTE: The auxiliary low-flow hydraulic circuit is not available for LR version.

Press the left-hand auxiliary pedal to operate the secondary hydraulic actuation for positioning.

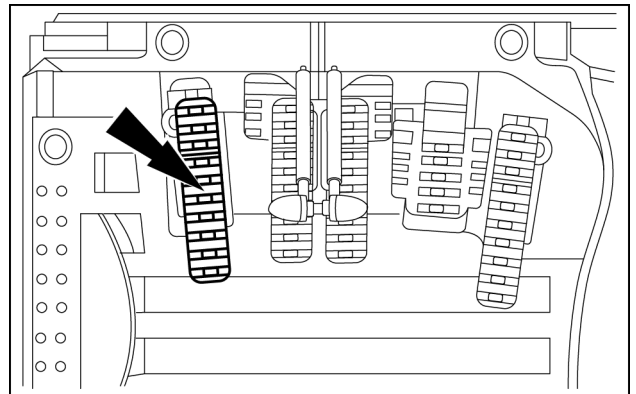

SMIL16CEX0335AA 15

To operate the auxiliary pedal, place the locking pin (**1**) in outward position.

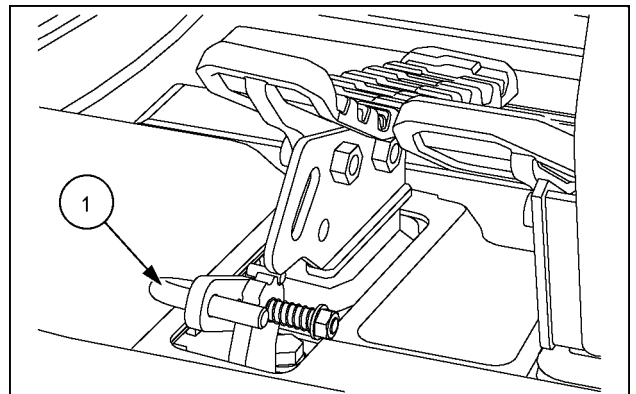

SMIL15CEX5130AA 16

NOTICE: the auxiliary pedal shall always be locked when not in use.

To lock the auxiliary pedal, engage the locking pin (**1**) in the locking hole (**2**).

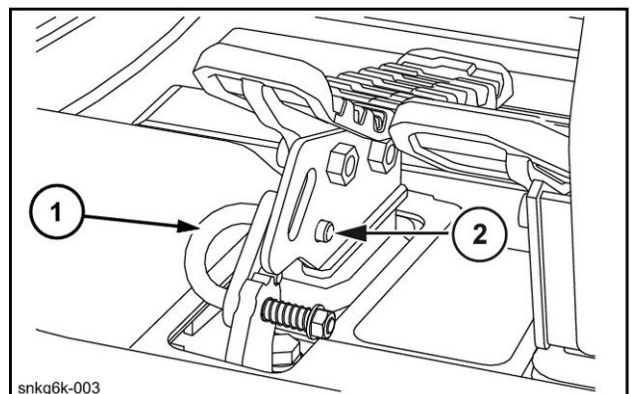

snkq6k-003

SNKQ6K-003A 17

CLICK HERE TO **DOWNLOAD** THE COMPLETE MANUAL

- Thank you very much for reading the preview of the manual.
- You can download the complete manual from: www.heydownloads.com by clicking the link below



- Please note: If there is no response to CLICKING the link, please download this PDF first and then click on it.

CLICK HERE TO **DOWNLOAD** THE COMPLETE MANUAL