

ORIGINAL INSTRUCTIONS

821G
921G
Tier 4B (Final)
Wheel Loader

OPERATOR'S MANUAL

Part number 51417050
1st edition English
November 2017



CLICK HERE TO **DOWNLOAD** THE COMPLETE MANUAL

- Thank you very much for reading the preview of the manual.
- You can download the complete manual from: www.heydownloads.com by clicking the link below



- Please note: If there is no response to CLICKING the link, please download this PDF first and then click on it.

CLICK HERE TO **DOWNLOAD** THE COMPLETE MANUAL

Electro-Magnetic Compatibility (EMC)

Interference may arise as a result of add on equipment which may not necessarily meet the required standards. Such interference can result in serious malfunction of the unit and/or create unsafe situations, you must observe the following:

- The maximum power of emission equipment (radio, telephones, etc.) must not exceed the limits imposed by the national authorities of the country where you use the machine.
- The electromagnetic field generated by the add on system should not exceed **24 V/m** at any time and at any location in the proximity of electronic components.
- The add on equipment must not interfere with the functioning of the on board electronics.

Failure to comply with these rules will render the CASE CONSTRUCTION warranty null and void.

Personal safety

Most accidents involving machine operation and maintenance can be avoided by following basic safety rules and precautions. Read and understand all the safety messages in this manual, the safety manual and the safety signs on the machine before you operate or service the machine. See your dealer if you have any questions.

READ THIS MANUAL COMPLETELY and make sure you understand the controls. All equipment has a limit. Make sure you understand the speed, brakes, steering, stability, and load characteristics of the machine before you start to operate this machine.

DO NOT remove this manual or the safety manual from the machine. See your dealer for additional manuals. Also see the manual information on the Title pages (first and second pages in front of the Table of Contents) of this manual.

The safety information given in this manual does not replace safety codes, insurance needs, federal, state, or local laws. Make sure that your machine has the correct equipment according to these rules or laws.

Additional safety messages are used in the text of the manual to show specific safety hazards.

NOTICE: *the safety messages in this chapter point out conditions which can happen during the normal operation and maintenance of your machine. These safety messages also give possible ways of dealing with these conditions.*

Support strut and service link

⚠ WARNING

Crushing hazard!

If you service the machine with the loader lift arms raised, always use the support strut. Remove the support strut from the storage position and place the strut onto the cylinder rod. Install the retaining bolt entirely into the strut. Lower lift arms onto the support strut.

Failure to comply could result in death or serious injury.

W0140A

If you service the machine with the loader lift arms raised, always use the support strut.

Support strut

1. Empty the loader bucket, park the machine on a level surface, raise the loader lift arm to approximately **2.1 m (7 ft)**, turn the engine off and set the parking brake before exiting the cab. Maintain the bucket in a dumped position. Remove the support strut from the storage position by removing the retaining bolt.

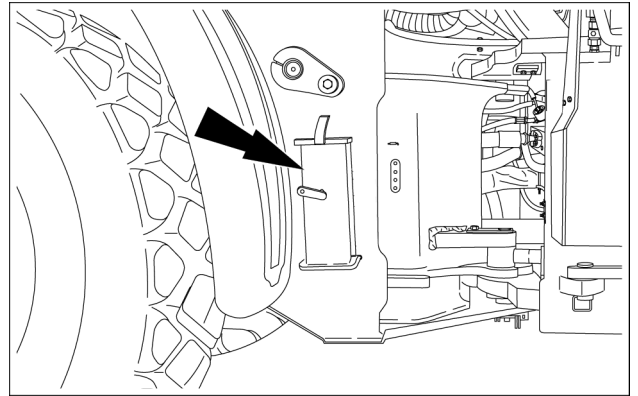

LEIL15WHL1850AA 1

2. Place the support strut onto the cylinder rod with the guide lock tab on the top of the cylinder and pointing toward the bucket. Install the retaining bolt entirely into the support strut using all threads. Slowly lower the lift arms onto the support strut. Maintain the bucket in a dumped position.

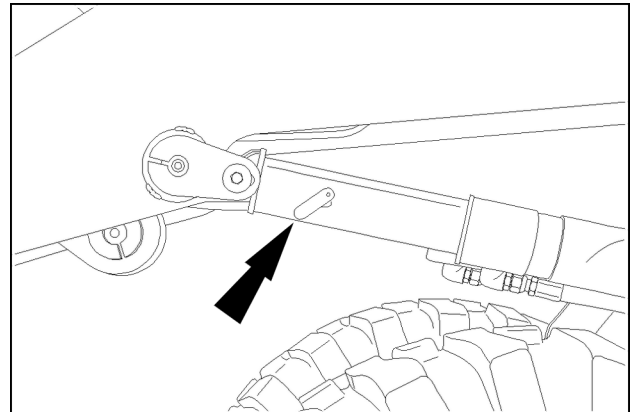

RCPH10WHL061BAL 2

Empty tool

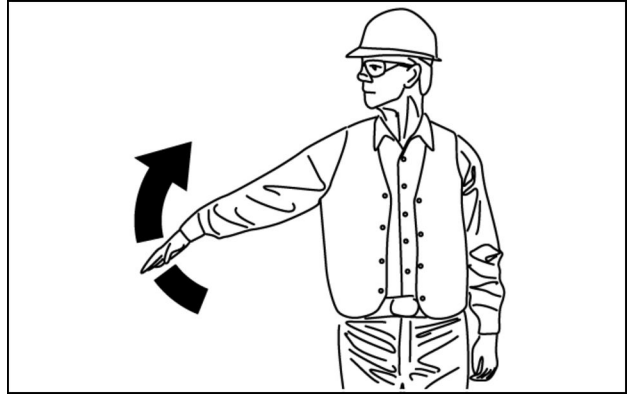

LEEN11T0024AA 20

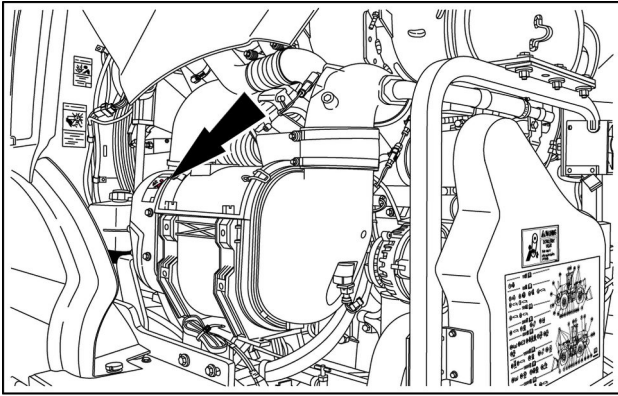

LEIL13WHL0300AA 33

Location: air cleaner housing.

WARNING
Explosion hazard!
Do not use ether.
Failure to comply with this warning could result in death or serious injury.

North American decal number: 47728994
French Canadian decal number: 47728074
Spanish decal number: 8603094



8603092_ 34

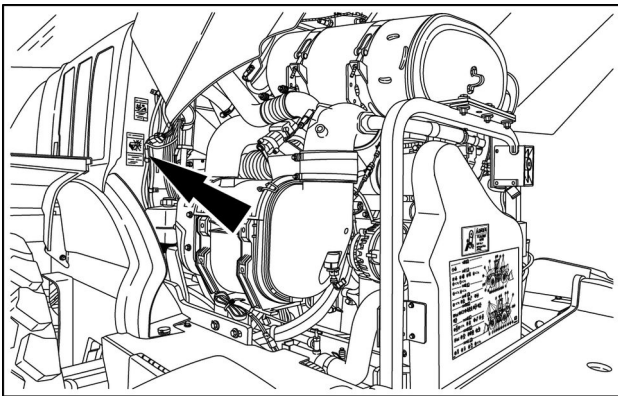

LEIL13WHL0302AA 35

Location: left-hand and right-hand side of the machine, near the fan guard.

WARNING
Entanglement hazard!
Keep clear or stop the engine before servicing.
Failure to comply with this warning could result in death or serious injury.

North American decal number: 87488606
French Canadian decal number: 87488607
Spanish decal number: 87488608



87488606_B 36

Operator's seat

Overview

▲ WARNING

Loss of control hazard!

DO NOT make seat adjustments while the machine is in motion. All seat adjustment should be made with the machine stationary and the parking brake applied. Failure to comply could result in death or serious injury.

W0293A

Standard operator seat – Mechanical suspension

Console Fore/Aft adjustment

Lift up the handle and adjust the control carrier equipment forward or backward as required.

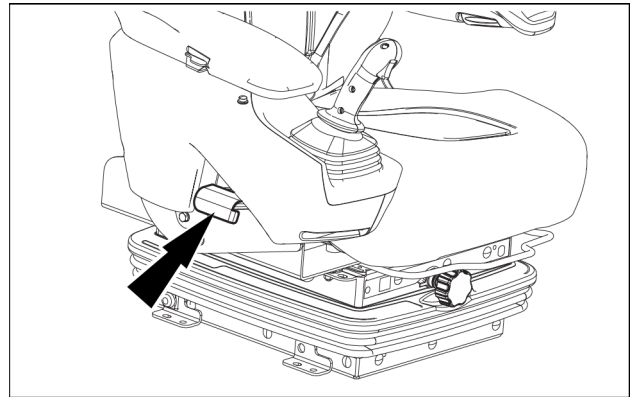

LEIL17WHL1484AB 1

Weight adjustment

Use the knob to increase or decrease the weight resistance. Adjust the seat as operator preference and comfort.

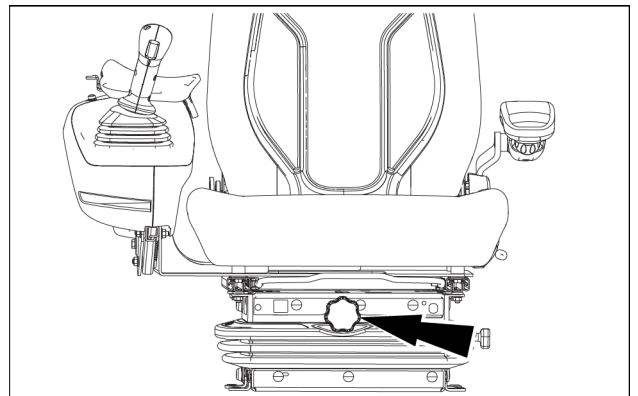

LEIL17WHL1485AB 2

Seat Fore/Aft adjustment

Pull the slide adjustment lever up and adjust the seat forward or backward as required. Release the lever to lock the seat in position. Always make adjustments from the front center of the adjustment bar.

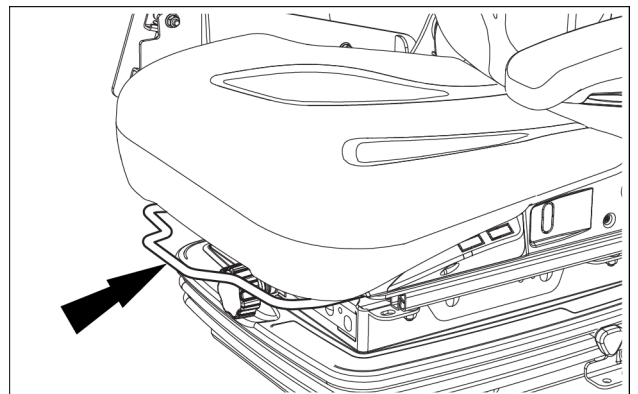

LEIL16WHL1386AB 3

Steering column

⚠ WARNING

Hazard to bystanders!

Always sound the horn before starting the machine. Make sure the work area is clear of other persons, domestic animals, tools, etc. before you operate the machine. Never allow anyone in the work area during machine operation.

Failure to comply could result in death or serious injury.

W0304A

Right-hand multifunction lever



1. Horn
Push the horn button in to actuate the horn.

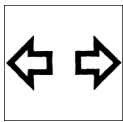

2. Turn signal lever
Push the control lever up to signal a left turn. Pull the lever down to signal a right turn. Move the lever manually to the center position to stop the signals.

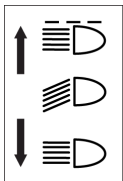

3. High beam headlights and flashing
Pull the multifunction lever to turn on the high beam headlights. Push the multifunction lever for flashing.

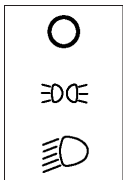

4. Driving light wheel
Rotate the wheel (4) to set one of the three positions:
0 – Lights OFF
1 – Marker/position lights
2 – Low beam headlights

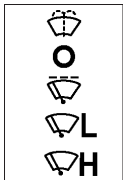

5. Front wiper/washer wheel
Rotate the wheel (5) to set one of the four positions:
0 - OFF position.
I - ON position – Rotate clockwise the wheel (5) to the first position to activate the front wiper.
L - INTERMITTENT - Rotate clockwise the wheel (5) to the second position to activate the front wiper at the intermittent speed.
H - CONTINUOUSLY - Rotate clockwise the wheel (5) to the third position. The front wiper runs continuously.
WASH - Rotate counterclockwise and hold the wheel (5) for washer fluid.

6. Front wiper speed wheel
Rotate the wheel (6) to adjust and set the front wiper intermittent speed. There are six settings for the front wiper intermittent speed.

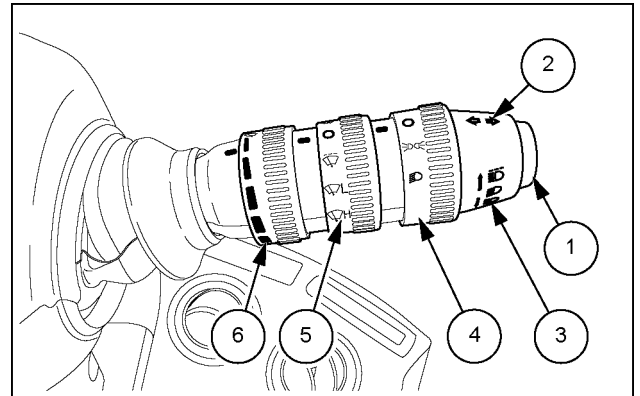

LEIL16WHL0542AB 1

9. Arm pad release

Lift arm pad to raise.
Rotate lever to release and lower.

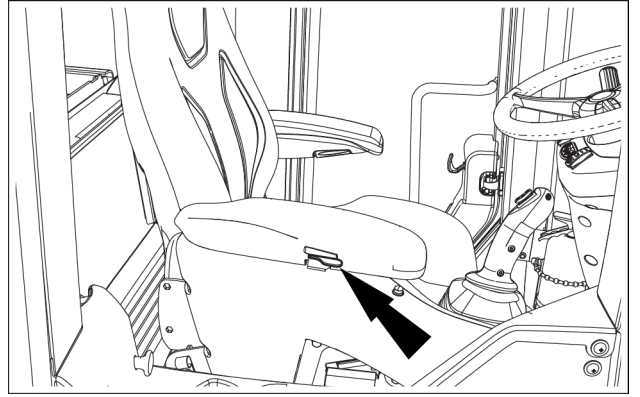

LEIL16WHL1305AB 9

2. Auxiliary F-N-R switch

The F-N-R function of the transmission control lever may be moved to the loader control lever for operating efficiency. The auxiliary F-N-R switch (1) is located on the joystick or next to the control levers.

All the following steps are required to use this transmission shift function:

1. Service brake pressure must be at operating pressure.
2. The transmission control lever on the left-hand side of the steering column must be in NEUTRAL.
3. F-N-R switch (1) on the joystick or next to the control levers must be in NEUTRAL.
4. Machine speed must be zero.
5. Engine must be running.

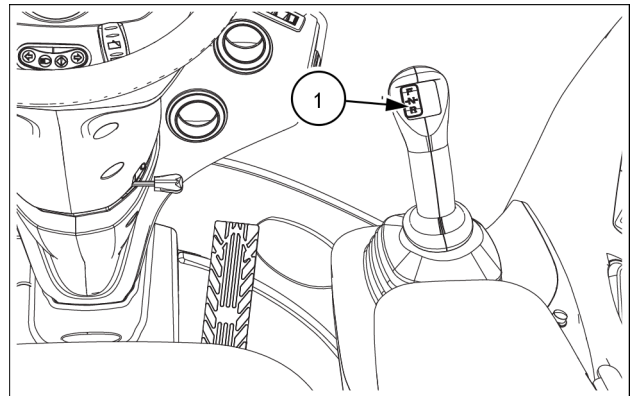

LEIL16WHL1288AB 12

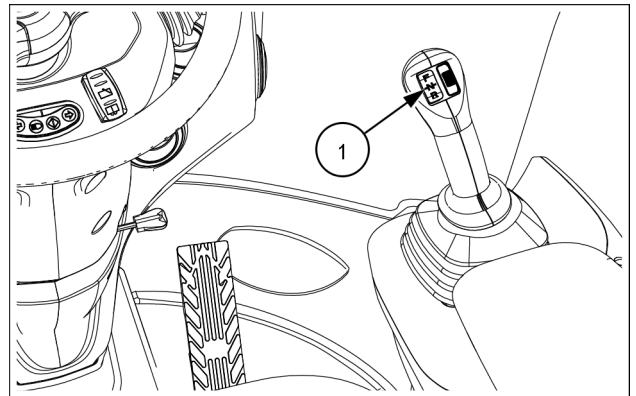

LEIL16WHL1331AA 13

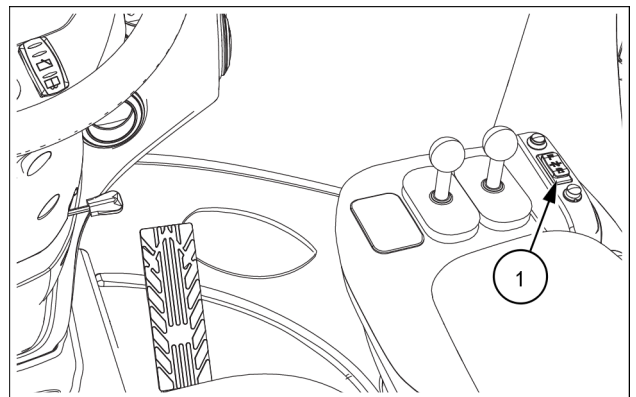

LEIL16WHL1303AA 14

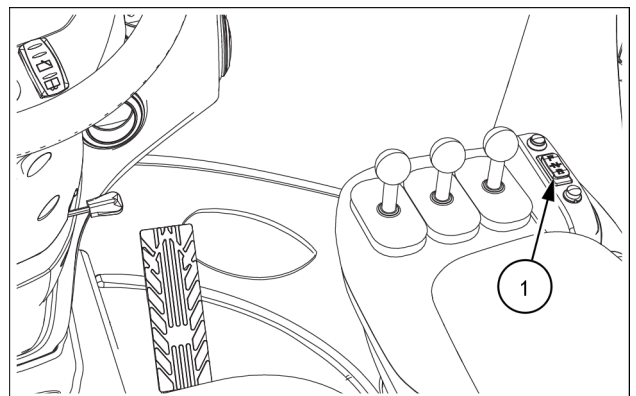

LEIL16WHL1302AA 15

Display

Display description

LCD multifunction display

The Liquid Crystal Display (LCD) multifunction display is located above the multifunction keypad.

Information will be displayed on the LCD as directed by the operator or automatically by machine operations. The screen offers prompts to assist the operator when programming machine functions and/or performing diagnostics.

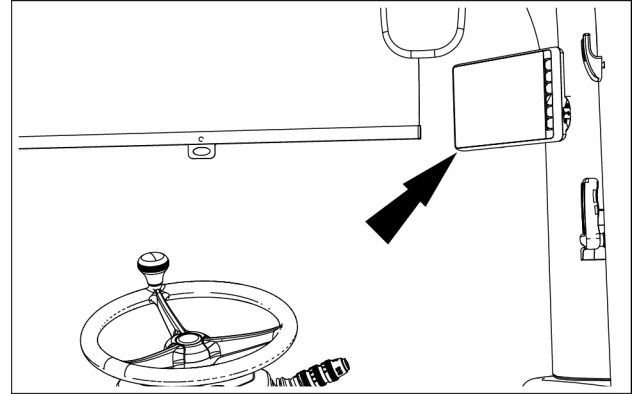

LEIL16WHL0996AB 1

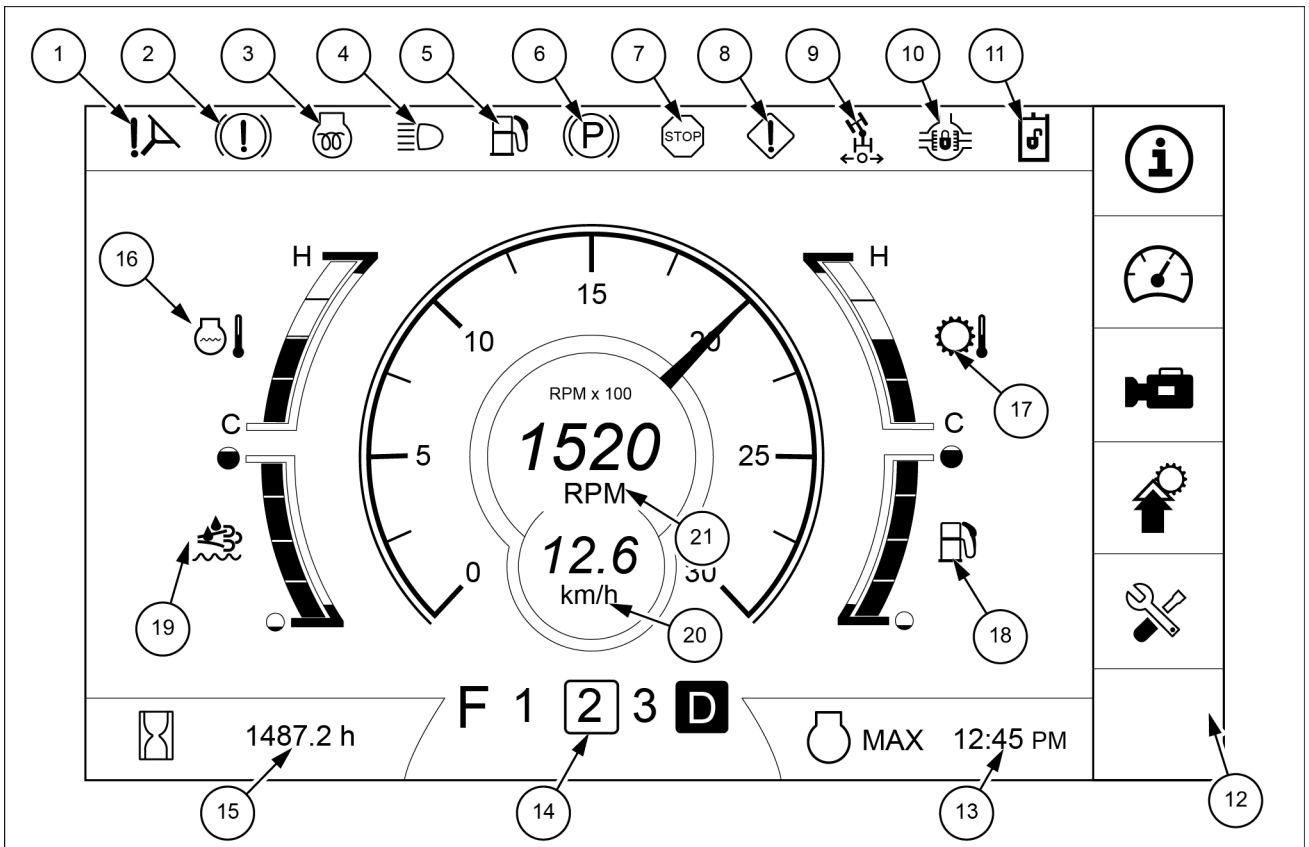

LEIL16WHL1103FB 2

→ Fan selections

- Auto Fan
- Fan Reverser Interval
- Fan Reverser Duration

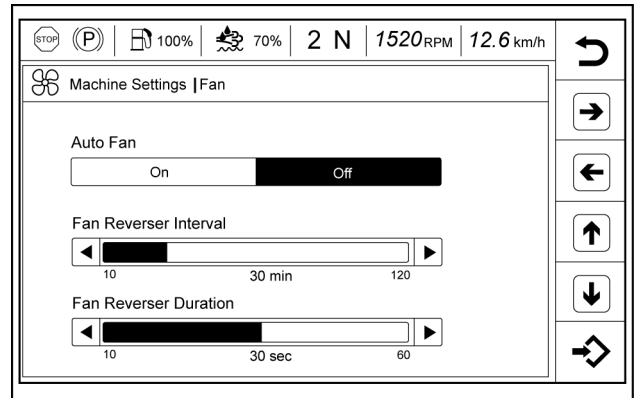

LEIL15WHL0532AA 25

Joystick Steering

Use the keypad on the right-hand of the display to select the key to switch to the “Joystick Steering” settings.

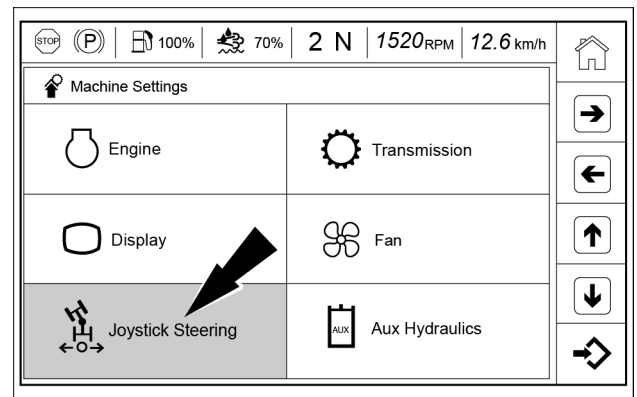

LEIL16WHL0409AB 26

→ Joystick Steering selections

Joystick Steering

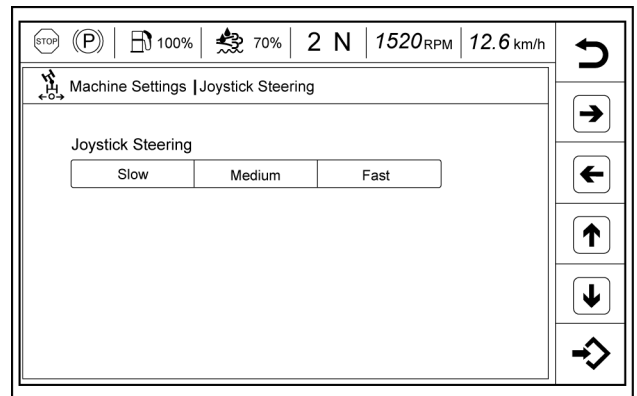

LEIL15WHL0533AA 27

Aux Hydraulics

Use the keypad on the right-hand of the display to select the key to switch to the “Auxiliary Hydraulics” settings.

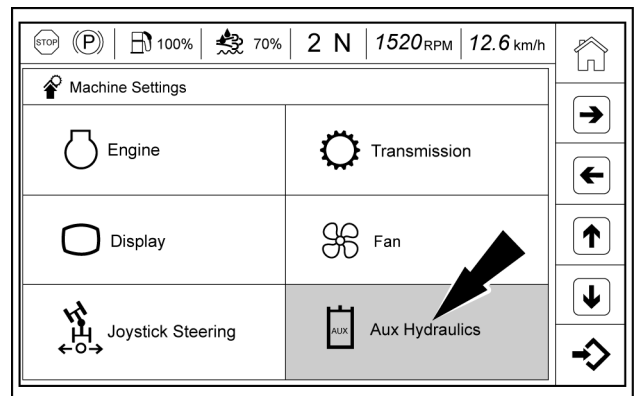

LEIL15WHL0636AA 28

Transmission clutch calibration in progress

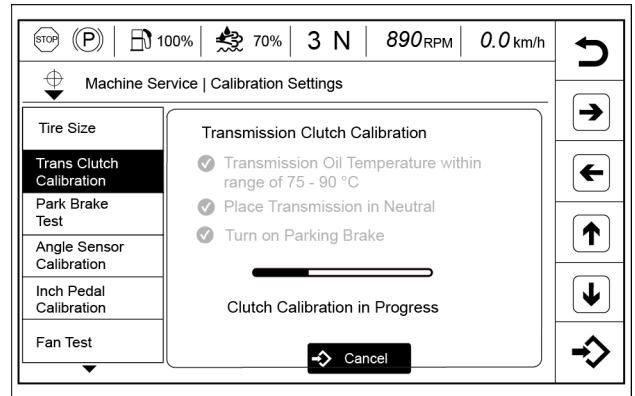

LEIL17WHL0953AA 61

Transmission clutch calibration is successful.

Select "Done" to exit. Restart the machine.

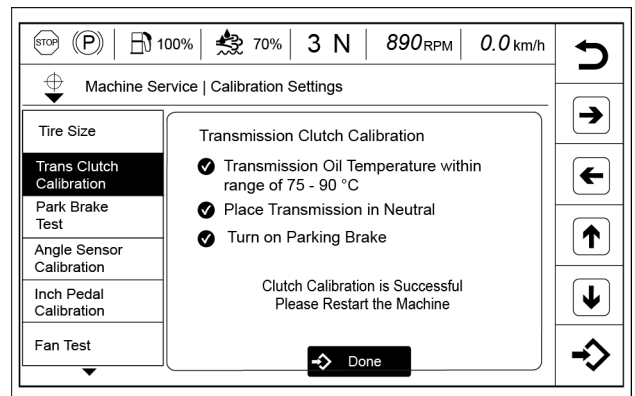

LEIL17WHL0954AA 62

→ Parking Brake Test

Conditions to be satisfied to start the parking brake test:

- Turn On parking brake
- Place Transmission in 3rd Gear Forward

Select "Start" to proceed with the parking brake test.

NOTICE: before starting the test make sure you have room to move forward.

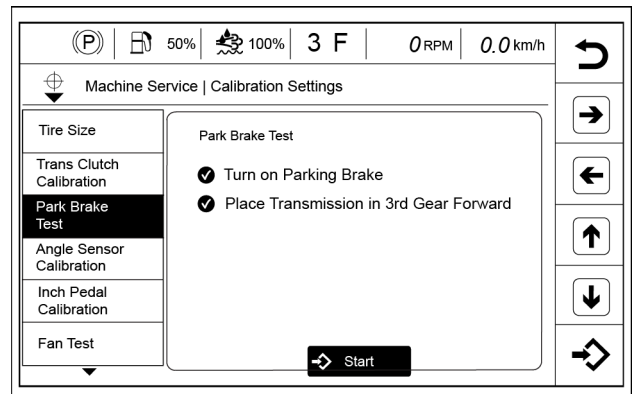

LEIL17WHL1647AA 63

Parking brake test in progress

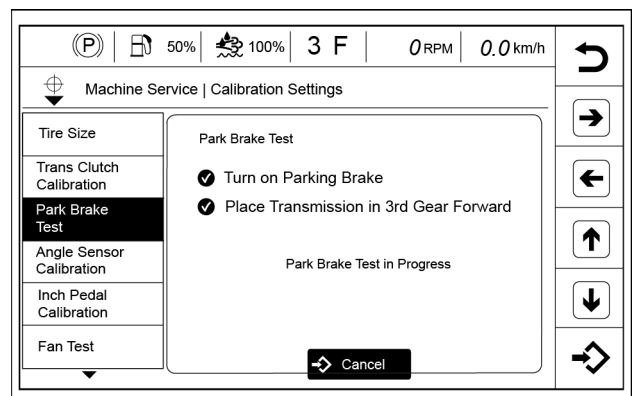

LEIL17WHL1648AA 64

Status and warning icons

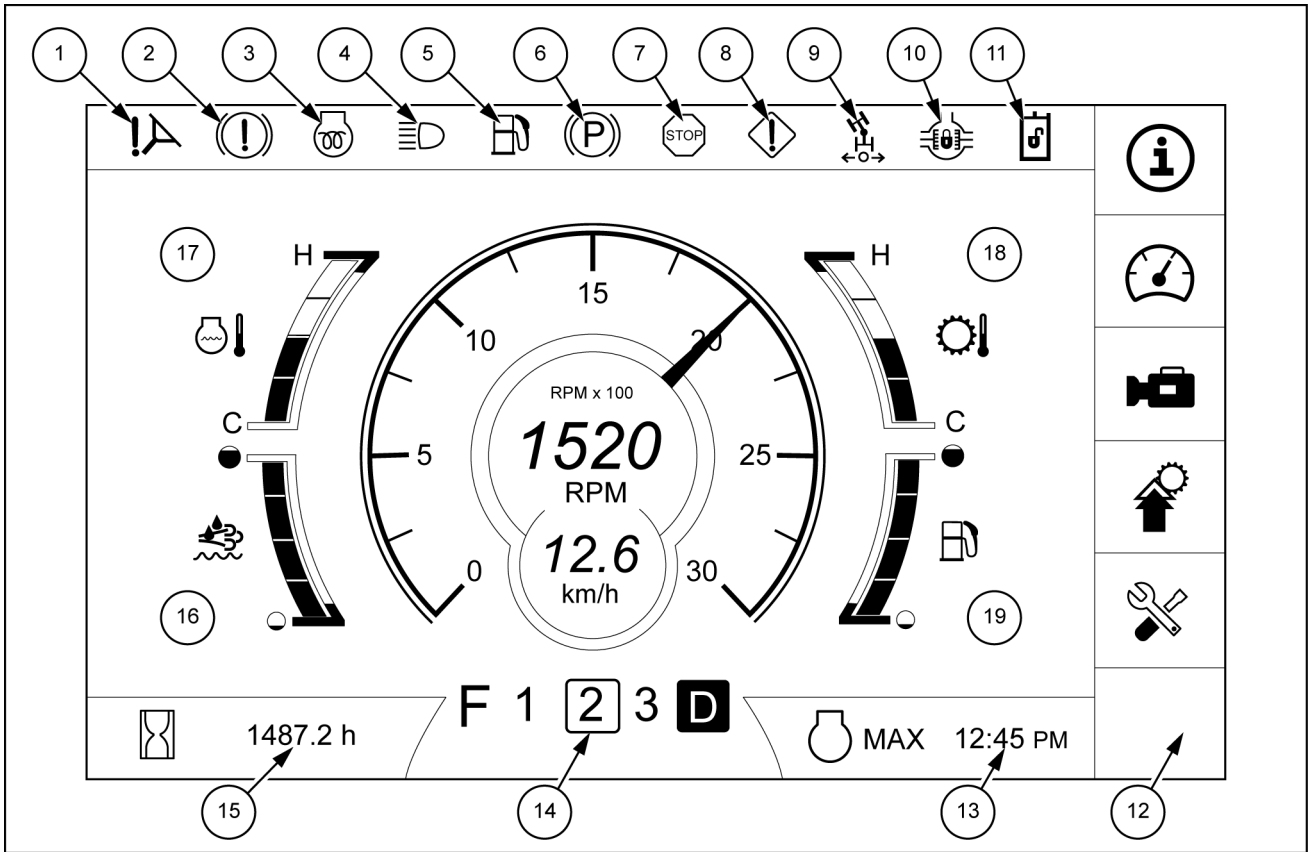

Indicators

The multifunction display will check each monitored system when you turn the key switch to the ON position. All lights will illuminate, and the warning alarm will sound for **3 s**. At the end of this check all monitored systems will return to normal operation. If there is an open circuit between a sensor and the multifunction display on some circuits, the lights will flash and the warning alarm will sound for **5 s**.



1. Secondary steering pressure (if equipped, red)

This indicator illuminates when the primary steering system pressure is too low. The alarm sounds continuously and the stop master indicator turns red. If this situation occurs, stop the machine immediately and contact your dealer.



2. Brake pressure indicator (red)

The indicator illuminates when the brake system pressure is too low. The alarm sounds continuously, and the stop master indicator will be red. Stop the machine, and correct the problem.



3. Engine grid heater lamp indicator (if equipped, orange)

To start the engine, turn the key switch to the ON position. The indicator illuminates when the engine grid heater is operating. Wait until the indicator light goes OFF before moving the key switch to the START position to start the engine. The indicator light may come on again during cranking and shortly after the engine starts for post heating of the air.





4. High beam lamp indicator (blue)

The indicator illuminates when the driving high beam lamps are ON.

DIESEL EXHAUST FLUID (DEF)/AdBLUE® instrumentation warning

Your machine is equipped with a warning system to inform the operator of the **DEF/AdBLUE®** level, system malfunctions and engine power loss that may result from the SCR system for reducing exhaust emissions.

OPERATING CAPACITY	NORMAL	NORMAL	REDUCED (stage 1)	LIMITED* (stage 2)	LIMITED* (final stage)
OPERATION		No engine derate	Gradually derates to LIMITED*	Engine speed and torque gradually derate to low idle but the engine will not shut down	Engine speed and torque are derated to low idle, rendering unit movable but the engine will not shut down
% DEF/AdBLUE® in tank	100% - 10%	10%	5%	0%	0%
DEF/AdBLUE® level	≥ 2 bar	2 bar	1 bar	0 bar	0 bar
Master indicators	No flashes or alarm	 DEF/AdBLUE® gauge flashes	 DEF/AdBLUE® gauge flashes with audible alarm	 DEF/AdBLUE® gauge flashes with audible alarm. Refilling DEF/AdBLUE® fluid will restore machine to full operating capacity.	

* PERFORMANCE REDUCTION ARE GRADUAL

- Approximately **95 min** from stage 1 to final stage
- Time may vary depending on the working condition
- No limit to number of re-starts

Starting the unit

Starting the engine

▲ WARNING

IMPROPER OPERATION OF THIS MACHINE CAN CAUSE DEATH OR SERIOUS INJURY.

MAKE SURE THAT EVERY OPERATOR:

- is instructed in the safe and proper use of this machine.
 - reads and understands the operator's manual for this machine.
 - reads and understands **ALL** safety signs on the machine.
- Failure to comply could result in death or serious injury.

W0188A

Before operating the machine

Before operating this machine, complete the following procedures:

1. Check the level of all fluids (engine oil, fuel, transmission oil, **DEF/AdBLUE®**, hydraulic fluid, and coolant) and make sure that the fluids and lubricants are suitable for prevailing conditions.
2. Carry out the daily maintenance operations.
3. Inspect the machine, look for any signs of possible leakage and check the hoses. Tighten or replace as necessary.
4. See "Run-in period of a new machine" - Chapter 4 in this manual, if the machine is new or if the engine has been reconditioned.
5. Check the tires for any visible damage. Replace or repair as necessary. Check for correct tire air pressure and adjust the pressure if necessary.
6. Clean the steps and hand holds. Grease, oil, mud, or ice in winter on the steps and access handles can cause accidents. Keep the steps and the access handles clean at all times.
7. Clean or replace any decals which are illegible. See "Safety signs" - Chapter 2 in this manual for further information.
8. Make sure that the engine access panels and all doors are properly closed and latched.
9. Secure the cab door in either fully closed or fully opened position.
10. Remove any obstructions which hinder visibility. Clean the windshield, the windows and the rear view mirrors.
11. Check that no tools or other items have been left on the machine or in the operator's compartment.
12. Make sure no one is on or under the machine. The operator must be alone on the machine.
13. Make sure no one is standing in the machine working area.
14. Find out about current safety measures in use on the work site.
15. Work out a convenient means of escape from the machine (emergency exit via the windshield, the rear or side window glass) in the event of the cab door being jammed or the machine turning over.
16. Before undertaking any travel or working operations during hours of darkness, make sure the lighting and signaling equipment are fully operative.
17. Adjust the seat so that you can apply the foot brakes when your back is against the seat backrest.
18. Fasten and adjust the seat belt.
19. With the engine running and at operating temperature, check the instrument panel for correct indications.
20. Check the loader controls for correct operation.

Moving the unit

Enabling the Auxiliary F-N-R switch

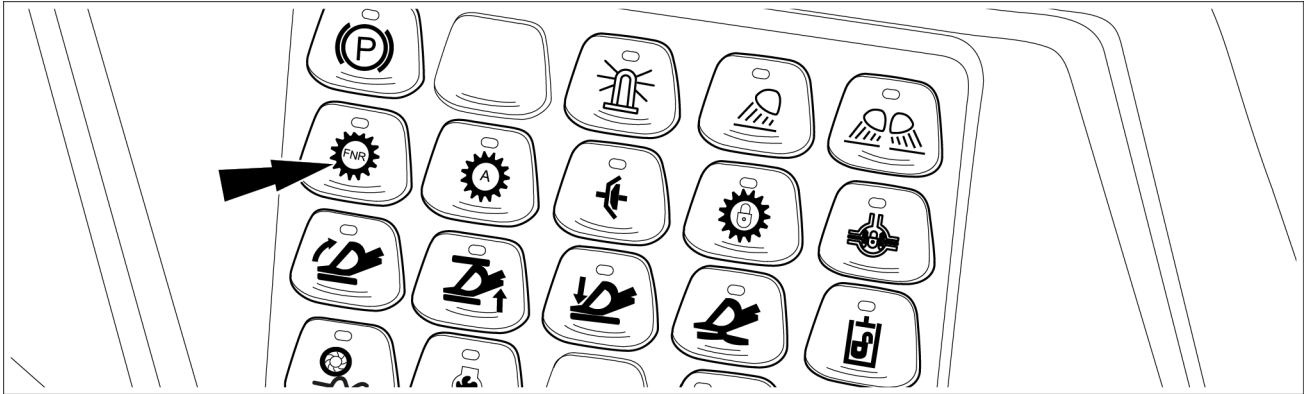

LEIL16WHL1127EA 1

You can enable the auxiliary F-N-R switch located on the joystick or next to the single axis levers after the following conditions have been completed:

1. the transmission controller is in NEUTRAL (left-hand side of the steering column);
2. the auxiliary F-N-R switch is in NEUTRAL;
3. the engine must be running;
4. the machine is stationary.

Push the auxiliary F-N-R button on multifunction keypad to enable the auxiliary F-N-R switch. The LED on the auxiliary F-N-R button lights up when the auxiliary F-N-R switch is activated.

If you move the transmission control lever from NEUTRAL or you stop the engine, the auxiliary F-N-R mode is deactivated.

Automatic mode

Automatic mode operation

Press the auto shift button on the multifunction keypad to put the transmission in the automatic mode.

Automatic shifting mode

When the transmission is in the automatic mode, the transmission will start out in second gear, and automatically shift up until the gear selected has been reached. The transmission will also shift down automatically as the speed decreases.

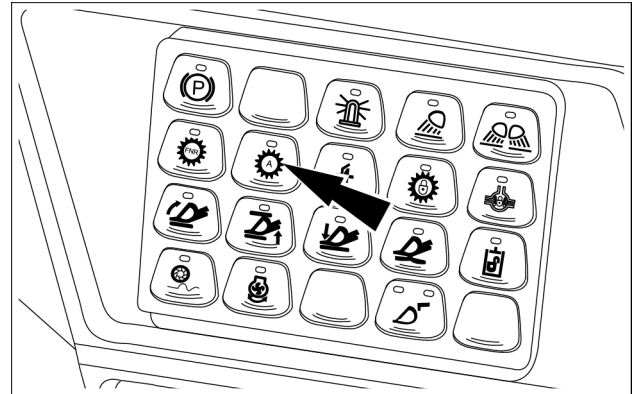

LEIL16WHL1125AA 1

Kick-down function, automatic mode

⚠ WARNING

Driving hazard!
Check all controls and safety devices in a safe, open area before starting work.
Failure to comply could result in death or serious injury.

W0248A

You can use the kick-down button to shift down through the gears in single steps. Each time you press the kick-down button, the transmission will shift down one gear range until the first gear is reached. Once the kick-down button has been pressed down, the transmission maximum gear allowed is lowered. The kick-down button will return to the automatic mode in one of the two cases, as follows:

1. when the transmission control lever changes gear;
2. when the transmission control lever is moved to NEUTRAL and then to FORWARD or to REVERSE.

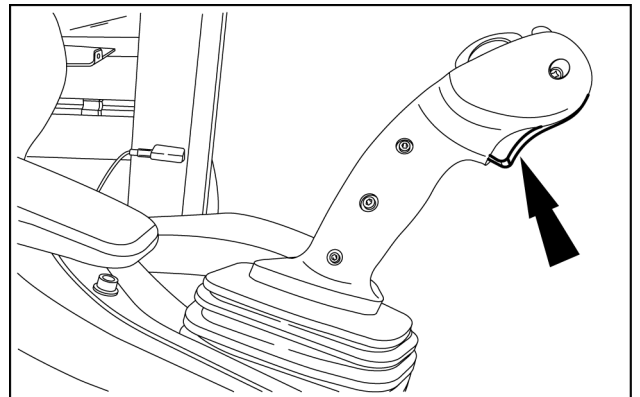

LEIL15WHL0516AA 2

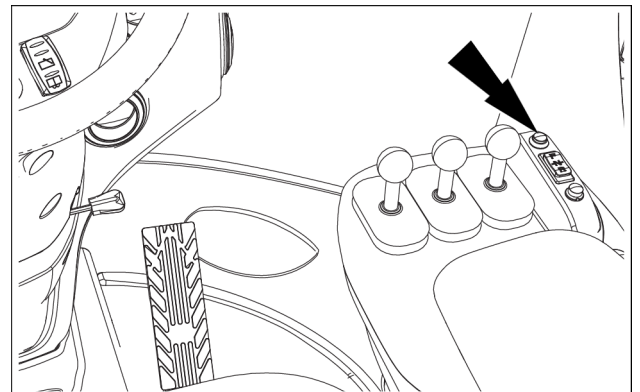

LEIL16WHL1302AA 3

Shuttle shifting (direction change)

It is not necessary to bring the machine to a complete stop when changing directions from forward to reverse or reverse to forward (transmission in either automatic or manual shifting modes). For smooth operation and operator comfort, reduce the engine speed before direction changes.

Engine coolant heater (if equipped)

The left-hand side of the engine block has a connection for installing an optional coolant heater. See your authorized dealer for this cold weather option.

Operating the machine in water

▲ WARNING

Driving hazard!

Do not operate the machine in a fast flowing stream. Fast flowing water can cause you to lose control of the machine.

Failure to comply could result in death or serious injury.

W0151A

- Make sure that the bottom of the stream, or water in which you will work, can support the weight of the machine.
- Do not allow the water level to reach the wheel rim.
- Before using the machine in water, inject the recommended quantities of fresh grease into the appropriate grease fittings.
- After completing the operation make sure to inject fresh quantities of grease into any fitting that was in water.

CLICK HERE TO **DOWNLOAD** THE COMPLETE MANUAL

- Thank you very much for reading the preview of the manual.
- You can download the complete manual from: www.heydownloads.com by clicking the link below



- Please note: If there is no response to CLICKING the link, please download this PDF first and then click on it.

CLICK HERE TO **DOWNLOAD** THE COMPLETE MANUAL

Joystick steering armrest adjustment

The left-hand armrest equipped with optional joystick steering controls can be adjusted for operator comfort.

To adjust the height of the armrest, use the lever **(1)**. Lower or raise the armrest into the desired position.

For tilt adjustment, loosen the knob **(2)**, then tilt the armrest into the desired position. Retighten the knob **(2)** once the adjustment is complete.

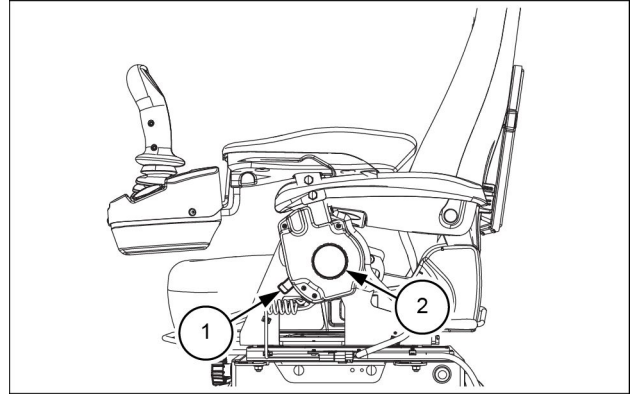

LEIL16WHL1405AB 2

Standard operator seat

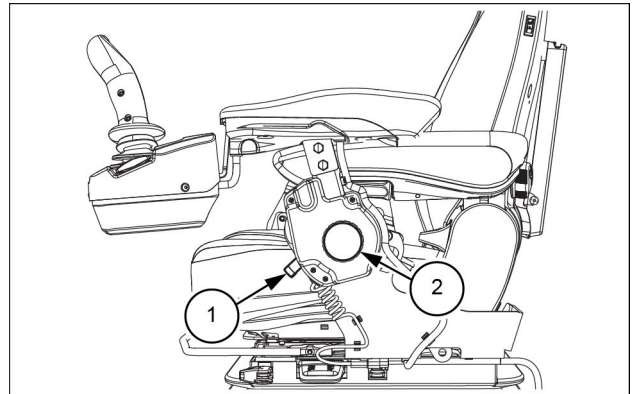

LEIL16WHL1404AB 3

Premium operator seat

General specification - Diesel fuel

Only use diesel fuel that conforms to North American standard **ASTM D975** Grade No. 2-D S15 or equivalent in your engine. Do not use any other low grade diesel fuel.

NOTICE: Use of other low grade diesel fuels will result in loss of engine power, high fuel consumption, and damage to the exhaust aftertreatment system (if equipped).

NOTE: When operating the machine in very cold climates, the use of winter blended fuel is permitted for a short period of time. See your fuel supplier for winter fuel requirements in your area.

Fuel conditioner

Diesel fuel conditioner is available from your CASE CONSTRUCTION dealer. Instructions for the use of the fuel conditioner is on the container.

The use of diesel fuel conditioner will:

- Clean fuel injectors, valves, and manifolds for increased service life
- Disperse insoluble gummy deposits that form in the fuel system

- Separate moisture from the fuel
- Stabilize fuel in storage

NOTICE: Use only CASE CONSTRUCTION approved biocide additives to prevent damage to the exhaust aftertreatment system (if equipped).

Washing of the cooling system

1. Empty the engine cooling system by draining the coolant into a suitable container.
2. Fill the system with clean water.
3. Start the engine and run the engine for at least **30 min.**

NOTE: make sure that you activate the heating system (if equipped) to circulate fluid through the heater core.

4. Repeat Steps 1 to 3 for a total of two washes.
5. Fill the system with OAT coolant.
6. Operate the engine until it is warm. Inspect the machine for leaks.

You can identify OAT coolant by its yellow color. Also, the decal shown is located near the fill point of the cooling system whenever the factory fill is **CASE AKCELA ACTIFULL™ OT EXTENDED LIFE COOLANT**. This decal is available in three different sizes. See the table below for the associated part numbers.

CNH Industrial part number	Size
47757330	50 mm x 50 mm
47757331	75 mm x 75 mm
47757332	100 mm x 100 mm

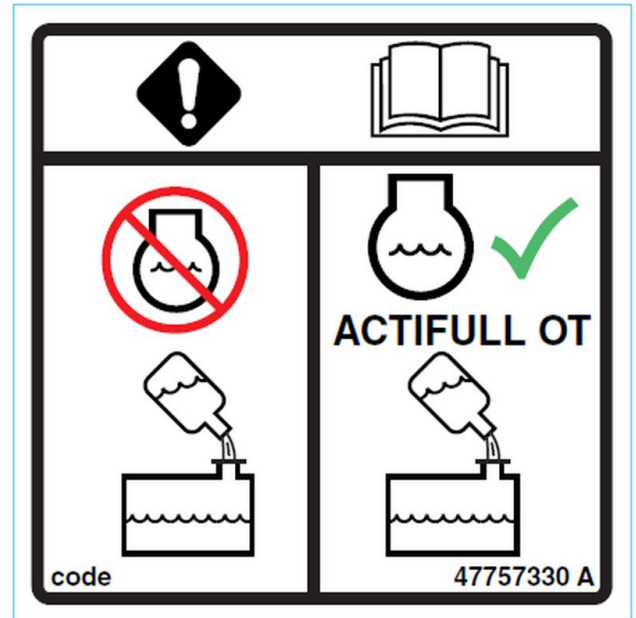

47757330 1

Definitions

Conventional coolant:

A coolant that relies on inorganic inhibitors such as silicates, nitrites, and phosphates for corrosion and cavitation protection.

Organic Acid Technology (OAT) coolant:

A coolant that relies on inhibitors such as organic acid salts (potassium and sodium salts) for corrosion and cavitation protection. The organic salts produce a protective film on the cylinder lines, avoiding cavitation erosion.

Clean Up Catalyst (CUC)

The Clean Up Catalyst (CUC) is located at the end of the SCR catalyst. The CUC converts the ammonia (NH_3) slip to nitrogen (N_2) and hydrogen (H_2). The CUC ensures that the ammonia slip to ambient is minimal.

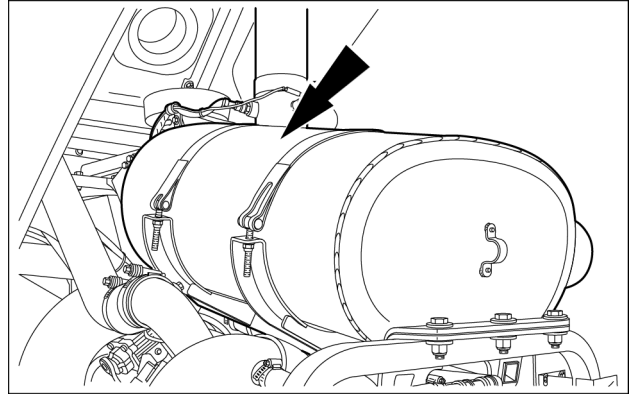

LEIL13WHL0308AA 5

Exhaust flap

The exhaust flap is a device located between the turbine and the exhaust system. The exhaust flap is equipped with a throttle valve which manages the rate and the "light off" temperature of the exhaust gas. The "light off" temperature indicates the temperature at which the catalytic process is initiated.

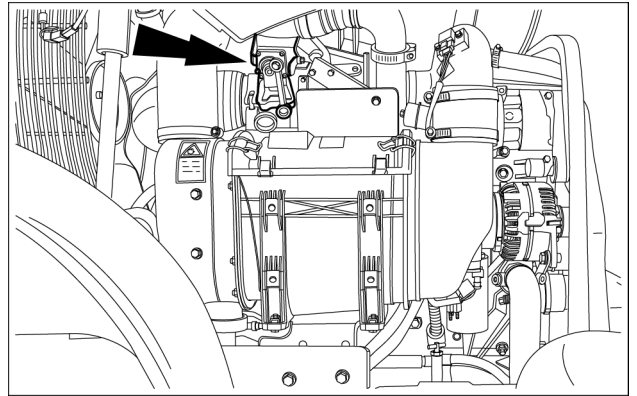

LEIL13WHL0312AB 6

Glossary

Acronym	Definition
DEF	DEF/AdBLUE®
ISO	International Organization for Standardization
MSDS	Material Safety Data Sheet
NOx	Nitrogen Oxide
PPE	Personal Protective Equipment
SCR	Selective Catalytic Reduction
ULSD	Ultra Low Sulfur Diesel
SM	Supply Module
DOC	Diesel Oxidation Catalyst
CUC	Clean Up Catalyst

Units of measure

Symbol	Definition
C	Centigrade
F	Fahrenheit
°	Degree
%	Percent
<	Less than
>	Greater than
mg/kg	Milligrams per kilogram

Hydraulic oil level - Check

⚠ WARNING

Pressurized hydraulic fluid can penetrate the skin and cause severe injuries. Hydraulic fluid is under extreme pressure. Rest the bucket or attachment on the ground. Shut the engine off, turn the key on, and move the hydraulic control lever through all movements several times to relieve residual pressure in the system. Failure to comply could result in death or serious injury.

W0161A

Check the level of the hydraulic oil tank every 50 hours.

Prior operation:

Keep all non-authorized personnel clear of the area. Park the machine on level ground, in neutral with the parking brake applied and the attachment lowered to the ground.

Service specifications	
Type of oil	CASE AKCELA HY-TRAN® ULTRACTION
821G total system capacity	178 L (47 US gal)
921G total system capacity	200 L (53 US gal)

Fluid level check

1. Check the oil level in the sight gauge, before you start the engine. If the oil is cold, the level is correct when the top of the oil is aligned with the lower indicator mark. If the oil is at operating temperature, the level is correct when the top of the oil is aligned with the upper indicator mark.
2. If oil is required, relieve all pressure in the system. Slowly loosen the tank cap, and top off until the proper oil level is reached. The hydraulic oil fill cap is located under the condenser core behind the operator's cab.

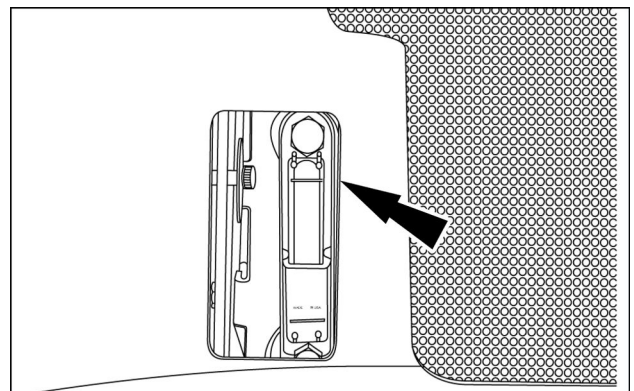

RCPH10WHL102AAH 1

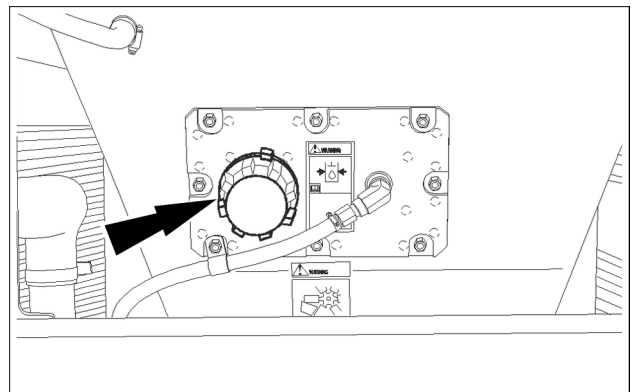

LEIL16WHL0078AB 2

Fuel pre-filter (Initial) - Replace

⚠ WARNING

Fuel vapors are explosive and flammable.

Do not smoke while handling fuel. Keep fuel away from flames or sparks. Shut off engine and remove key before servicing. Always work in a well-ventilated area. Clean up spilled fuel immediately. Failure to comply could result in death or serious injury.

W0904A

Change the fuel pre-filter when the machine is new and the hourmeter registers 100 hours. Change the pre-filter every 500 hours thereafter or more often if conditions so require or if fuel quality is poor.

Prior operation:

Park the machine on a firm, level surface. Lower the attachment to the ground. Apply the parking brake, and install the transport service link to prevent unexpected articulation movements.

Drain fuel prefilter condensation

1. Open the engine hood. Locate the pre-filter on the right-hand side of the machine.
2. Remove the connector. Open the drain valve on the fuel pre-filter by turning counterclockwise two or three turns. Drain the water and/or contaminants from the pre-filter into a suitable container until clean fuel flows. Do not allow fuel to spill on engine or ground.
3. Turn the pre-filter counterclockwise to remove.
4. Replace with a new pre-filter cartridge, turning clockwise until the cartridge meets the pre-filter head. Hand tighten firmly in place. Do not use a wrench to tighten. Replace the connector at the bottom of the pre-filter.
5. Use the pump at the top of the pre-filter to bleed air from the fuel system. Pump until fuel flows out of the bleed screw without air bubbles.

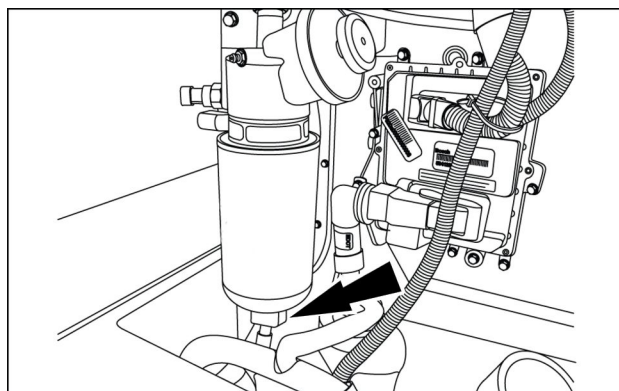

RCPH10WHL900AAH 1

4. Check the recirculation filter for debris or tears.
5. Shake the recirculation filter carefully to remove the surface dust.
6. Clean the recirculation filter with compressed air, working from the clean side towards the outside. The pressure must not exceed **2 bar (29 psi)** and the nozzle must be held at least **30 cm (11.8 in)** from the element.
7. Reinstall the recirculation filter.
8. Secure the recirculation filter cover.
9. Close the right-hand door.

Every 500 hours

Engine oil - Change

Change the engine oil every 500 hours thereafter or more frequently when the engine operating conditions are severe.

Prior operation:

Keep all non-authorized personnel clear of the area. Park the machine on level ground, in neutral with the parking brake applied and the attachment lowered to the ground.

Service specifications	
Type of oil	CASE AKCELA UNITEK NO. 1™ SBL CJ-4
821G capacity (with filter change)	13.25 l (14 US qt)
921G capacity (with filter change)	13.25 l (14 US qt)

NOTE: it is recommended to replace the engine oil filter when you replace the engine oil.

1. Lower the bucket/attachment to the ground and install the transport/service link into the locked position.

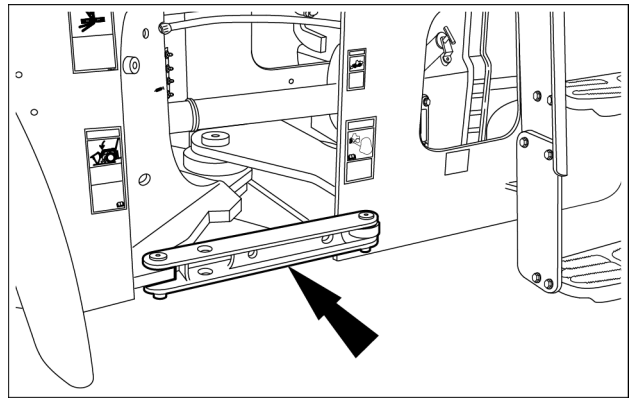

LEIL16WHL0048AB 1

2. Raise the engine hood. Remove the dipstick (1).

NOTE: when changing the engine oil, the oil flow rate is improved if you remove the oil fill cap or the dipstick from the engine while draining, and the oil is slightly warm.

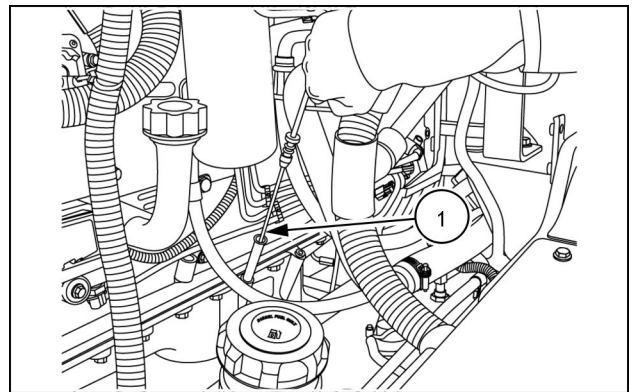

RCPH10WHL899AAH 2

3. Remove the remote drain cover to access the engine oil drain.

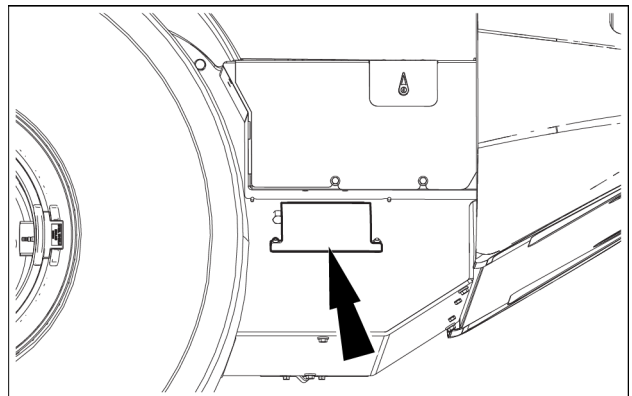

LEIL17WHL1597AB 3

Roll Over Protective Structure (ROPS) - Check

⚠ WARNING

Roll-over hazard!

After an accident, fire, tip over, or roll over, a qualified technician **MUST** replace the Roll-Over Protective Structure (ROPS) before returning the machine to the field or job site operation.

Failure to comply could result in death or serious injury.

W0134A

⚠ WARNING

Misuse hazard!

Your machine is equipped with an operator protective structure. **DO NOT** weld, drill holes, attempt to straighten, or repair the protective structure. Modification in any way can reduce the structural integrity of the structure.

Failure to comply could result in death or serious injury.

W0001B

Check and inspect the ROPS structure and the seat restraint system every 500 hours of operation.

Your machine is equipped with an operator Protective Structure, such as: Rollover Protective Structure (ROPS) or Falling Object Protective Structure (FOPS). A ROPS may be a cab frame or a two-posted or four-posted structure used for the protection of the operator to minimize the possibility of serious injury. The mounting structure and fasteners forming the mounting connection with the machine are part of the ROPS. The Protective Structure is a special safety component of your machine. **DO NOT** attach any device to the Protective Structure for pulling purposes. **DO NOT** drill holes into the Protective Structure. The Protective Structure and interconnecting components are a certified system. Any damage, fire, corrosion or modification will weaken the structure and reduce your protection. If this occurs, the Protective Structure **MUST** be replaced so that it will provide the same protection as a new Protective Structure. Contact your dealer for Protective Structure inspection and replacement. The mounting or suspension for the Protective Structure, operator seat and suspension, seat belts and mounting components and wiring within the operator's protective system **MUST** be carefully inspected for damage. All damaged parts **MUST** be replaced.

ROPS identification plate

The wheel loader has a ROPS identification plate showing the certification of the ROPS, gross weight, approval, regulation, and model number of the machine.

The ROPS identification plate is located under the operator's seat at the left-hand side.

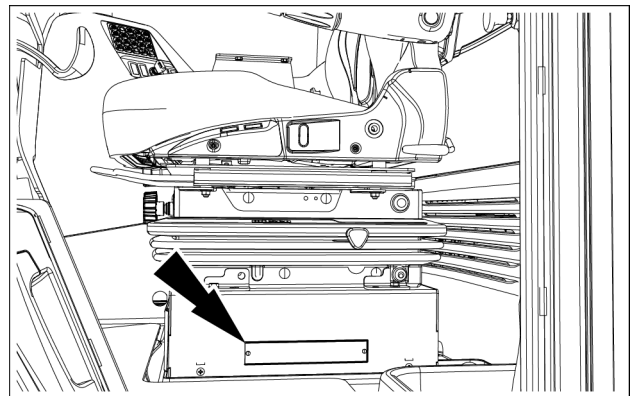

LEIL16WHL1167AB 1

- To replace the drive belt, remove the four screws that hold the protective cover in place.

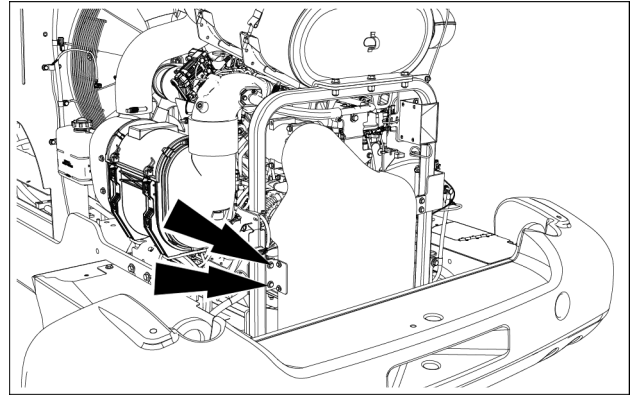

LEIL16WHL0585AA 2

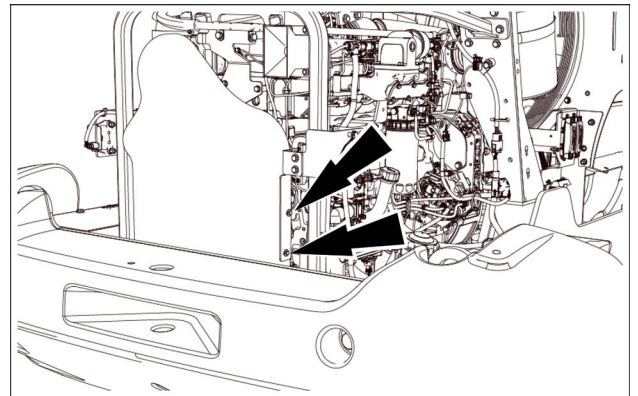

LEIL16WHL0586AA 3

- Use a 3/8 inch breaker bar to actuate the belt tensioner just enough to release the tension on the drive belt. Remove the drive belt.

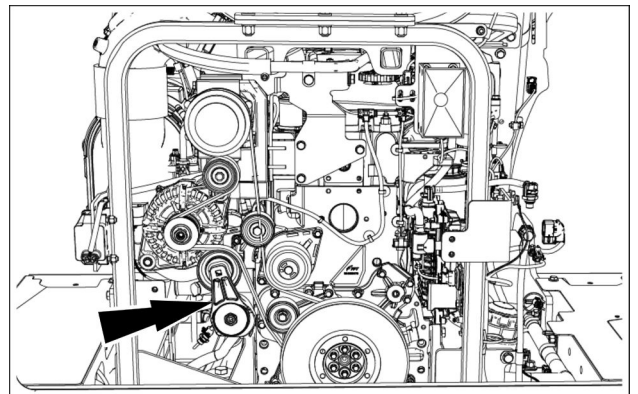

LEIL16WHL0587AA 4

- Place the drive belt around the pulleys of the crankshaft, the fan and the alternator.
- Raise the belt tensioner and install the drive belt over the water pump pulley.

NOTE: the water pump pulley has the smallest flange, which allows an easily installation of the drive belt.

- Lower the tensioner.
- Inspect all the pulleys to check if the belt is in the correct position.
- Start the engine and run at low idle for **60 – 90 s.**
- Stop the engine.
- Inspect the tensioner for a correct drive belt alignment.

NOTE: the minimum clearance from the front or the rear flange of the pulley to the belt is **1 mm.**

8. Check the oil level at the sight gauge.
9. Start the engine and check for oil leaks around the filter and drain plug.
10. Bring the transmission oil up to working temperature, and check the level again.

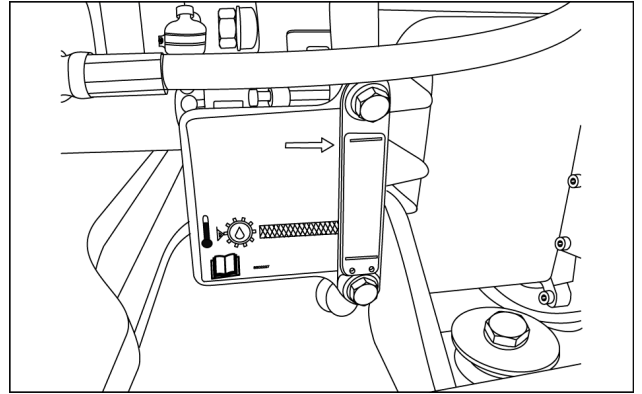

RCPH10WHL141AAH 2

Engine valve clearance - Check and adjust

Check valve adjustment

This should be performed by a qualified service technician every 2000 hours. Contact your authorized dealer.

Hoses and wiring

Check all hoses and wiring for damage. If damage occurred, see your authorized dealer for repair or replacement.

As required

Fuel pre-filter - Drain fluid

Drain water and sediment from the fuel pre-filter as required. In certain geographic regions and climates, it may be necessary to drain condensation more frequently.

Prior operation:

Park the machine on a firm, level surface. Lower the attachment to the ground. Apply the parking brake, and install the transport service link to prevent unexpected articulation movements.

Drain fuel filter condensation

1. Open the engine hood. Locate the pre-filter on the right-hand side of the machine.
2. Remove the connector. Open the drain valve on the fuel pre-filter by turning counterclockwise two or three turns. Drain the water and/or contaminants from the pre-filter into a suitable container until clean fuel flows. Do not allow fuel to spill on engine or ground.
3. Close the drain valve. Reconnect the electrical connection. Check for leaks.

NOTE: if it is necessary to bleed the fuel system, use the attached pump and the bleed screw at the top of the pre-filter housing.

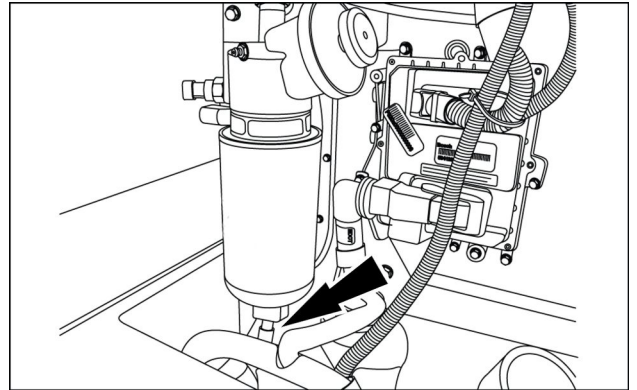

RCPH10WHL900AAH 1

Cab service - Check

Inspecting and cleaning the machine

⚠ WARNING

Moving parts!

Install all covers, panels, and guards after servicing or cleaning the machine. Never operate the machine with covers, panels, or guards removed.

Failure to comply could result in death or serious injury.

W0135A

Maintenance specifications

Inspect and clean	Periodically
-------------------	--------------

Clean immediately if oil or grease has been spilled on the machine. Clean with steam or a high pressure water jet.

Look for any leaks, and check the condition of all pipes and hoses.

Take the opportunity during this operation to make a visual check of all the welded components (in case of appearance of cracks), the bucket/attachment linkages and check the teeth and tooth tips for correct retention and for wear.

Cab headliner

The foam headliner in your cab decreases noise. To keep the headliner in good operating condition, remove dust with a vacuum cleaner.

NOTICE: DO NOT wash the headliner with water. Water can cause damage to the headliner and lower the noise control capacity of the headliner.

Operator's seat

⚠ WARNING

Chemical hazard!

Always wear protective clothing and goggles when cleaning with solvents, acids, or alkaline chemical agents. Always follow the chemical manufacturer's instructions.

Failure to comply could result in death or serious injury.

W0180A

Remove dust and dirt from the seat with a vacuum cleaner or soft brush. Clean stains with the correct use of a material cleaner.

Before removing stains, try to find what type and how old the stains are. Some stains can be removed with water or soap solution.

Cleaning fluid can be used for grease or oil stains. Carefully remove the item that caused the stain with a scraper or a dull knife.

Use a minimum amount of cleaner and a clean cloth. Move the cloth from the outside of the stain towards the center. When the stain is removed, use a clean cloth to dry the area to prevent a cleaning fluid pattern.

Battery - Replace

⚠ CAUTION

Heavy parts!

Machine batteries are extremely heavy. Make sure the battery is supported safely during the removal process.

Failure to comply could result in minor or moderate injury.

C0050A

⚠ WARNING

Chemical hazard!

When lifting a plastic-cased battery, excessive pressure on the end walls could cause acid to spill through the vent caps. Lift a plastic-cased battery with a battery carrier or with your hands positioned on opposite corners of the battery. Always wash your hands after handling.

Failure to comply could result in death or serious injury.

W0385A

Replacing the battery

1. Remove the bolts that hold the battery access cover in place, and remove the access cover.
2. Remove the terminal protection caps, disconnect cables (negative terminals) and then cables (positive terminals).
3. Remove the screws, the washers, and retainer. Remove the old batteries.
4. Install new batteries of the correct voltage and replace retainer, washers and screws.
5. Clean the cables and battery terminals, and coat with grease. Install new anti-sulfate pellets. Reconnect positive cable ends to positive terminals first. Reconnect negative cable ends to negative terminals, and install the terminal protection caps.
6. Replace the battery access cover and the bolts on machine.

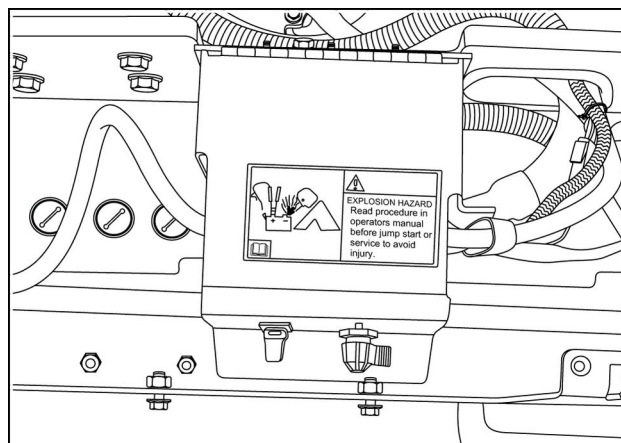

RCPH10WHL421AAH 1

9. Place a suitable container below the **DEF/AdBLUE®** supply tank.
Remove the Urea Quality Sensor (UQS), allow to drain the **DEF/AdBLUE®** through the UQS hole.
Reinstall the UQS.
10. Remove the batteries, clean the battery housings and make sure not to leave any traces of acid. Store the batteries safely in a cool and dry location, where the temperature will be higher than **0 °C (32.0 °F)**.
11. Paint any areas where the paint shows signs of deterioration.
12. Plug the air filter inlet and the exhaust pipe.
13. Remove the starter switch key and place a "DO NOT OPERATE" label on the right-hand control arm.
14. Lock the hoods and the cab door.
15. If equipped with attachment quick coupler, apply anti-seize to the coupler locking pins and bores.

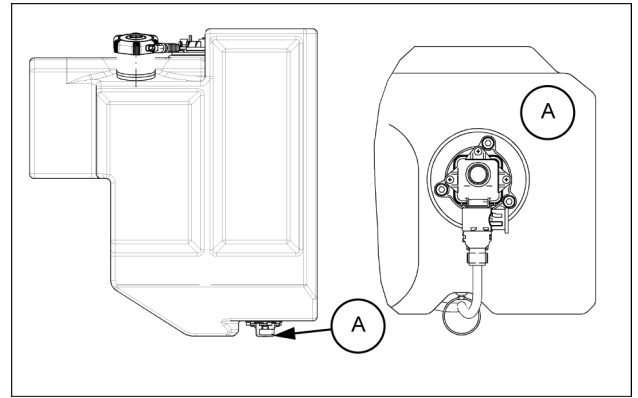

LEIL14WHL0207AB 2

921G Drivetrain - Optional 5 Speed Transmission

5F/3R Proportional with Electronic Control Module torque sensing autoshift/manual shift and modulation		
Gears	Helical cut	
Gear ratios	Forward	Reverse
1st	3.921	3.718
2nd	2.255	2.138
3rd	1.466	0.894
4th	0.942	
5th	0.613	
Torque converter stall ratio	2.350:1	
Rear axle oscillation	24° total	
Standard Axles	Front	Rear
Differential	Limited slip on front and rear axles	
Differential ratio	4.11	4.11
Planetary ratio	6.00	6.00
Final axle ratio	24.67	24.67
Planetaries	Outboard	
Service brakes	Hydraulically actuated, maintenance-free, multiple wet disc w/accumulator to all four wheels	
Parking brakes	Spring-applied hydraulic release disc on transmission output shaft	
Travel speeds	Forward	Reverse
1st	6.4 km/h (4.0 mph)	6.8 km/h (4.2 mph)
2nd	11.1 km/h (6.9 mph)	11.7 km/h (7.3 mph)
3rd	17 km/h (10.6 mph)	27.7 km/h (17.2 mph)
4th	26.3 km/h (16.3 mph)	
5th	40 km/h (25 mph)	

NOTE: travel speeds @ full engine throttle and lock-up converter engaged.

921G Cylinder Specifications

Lift cylinder	
Bore diameter	152.4 mm (6.0 in)
Rod diameter	88.9 mm (3.5 in)
Stroke	845.7 mm (33.30 in)
Dump cylinder	
Bore diameter	177.8 mm (7.0 in)
Rod diameter	101.6 mm (4.0 in)
Stroke	600 mm (23.6 in)
Steer cylinder	
Bore diameter	82.6 mm (3.25 in)
Rod diameter	44.5 mm (1.75 in)
Stroke	481.9 mm (18.97 in)

Instrumentation Gauges

Speedometer	Engine Coolant Temperature (ECT)	Gear position
Tachometer	Hydraulic oil temperature	Transmission modes
Hourmeter	Transmission oil temperature	Travel selected (FNR)
Fuel level	DEF level	Work mode

8 - SPECIFICATIONS

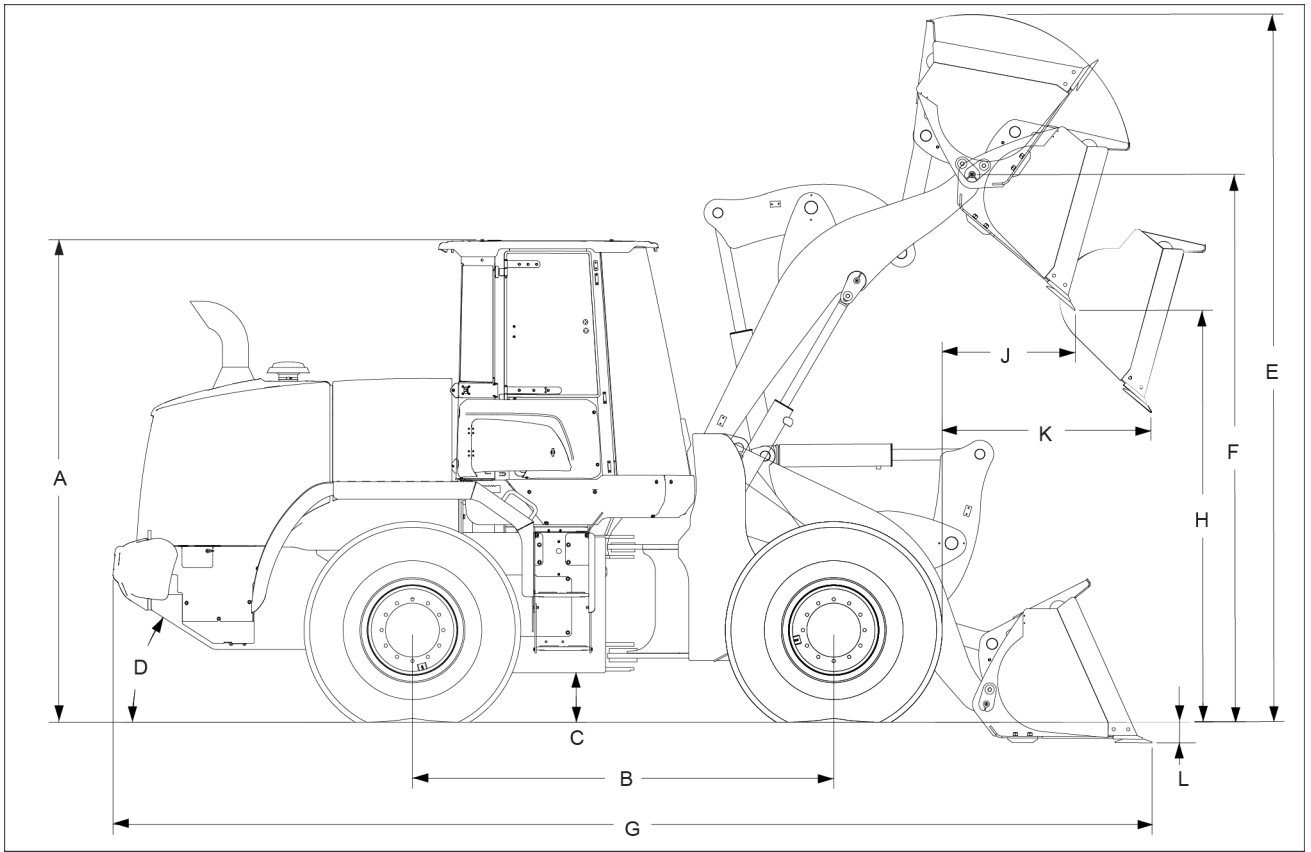

LEIL16WHL0629FB 8

821G Z-Bar Specifications - 2.7 m³ (3.5 yd³) Blade / 2.4 m³ (3.2 yd³) Teeth - Pin On

	Bucket with Bolt-on Edge	Bucket with Teeth
ISO Bucket Specifications		
Capacity (heaped)	2.68 m³ (3.50 yd³)	2.45 m³ (3.20 yd³)
Bucket width (maximum outer)	3030 mm (119.3 in)	3027 mm (119.2 in)
Dimensional Outline Specifications		
A (top of cab height)	3458 mm (136.1 in)	3458 mm (136.1 in)
B (wheelbase)	3340 mm (131.5 in)	3340 mm (131.5 in)
C (ground clearance)	431 mm (17.0 in)	431 mm (17.0 in)
D (rear angle of departure)	29°	29°
Overall width w/o bucket	2829 mm (111.4 in)	2829 mm (111.4 in)
Centerline tread width	2230 mm (87.8 in)	2230 mm (87.8 in)
Turning radius (outside of tires)	6003 mm (236.3 in)	6003 mm (236.3 in)
Turning angle from center	40°	40°
Total turning angle	80°	80°
E (fully raised with spillguard)	5763 mm (226.9 in)	5764 mm (226.9 in)
F (hinge pin - fully raised)	4561 mm (179.6 in)	4562 mm (179.6 in)
G (overall - bucket level on ground)	8322 mm (327.6 in)	8470 mm (333.5 in)
H (dump - fully raised, 45° dump)	3535 mm (139.2 in)	3440 mm (135.4 in)
J (reach - fully raised, 45° dump)	1102 mm (43.4 in)	1214 mm (47.8 in)
K (reach - 2.13 m (7.0 ft), 45° dump)	2062 mm (81.2 in)	2139 mm (84.2 in)
L (dig depth)	130 mm (5.1 in)	131 mm (5.2 in)
ISO Load Specifications		
Operating Weight (without load)	18286 kg (40314 lb)	18223 kg (40175 lb)
Operating load	4623 kg (10193 lb)	4698 kg (10358 lb)
Tipping load		
Machine straight	11440 kg (25220 lb)	11609 kg (25593 lb)
40° turn	9247 kg (20386 lb)	9397 kg (20716 lb)

8 - SPECIFICATIONS

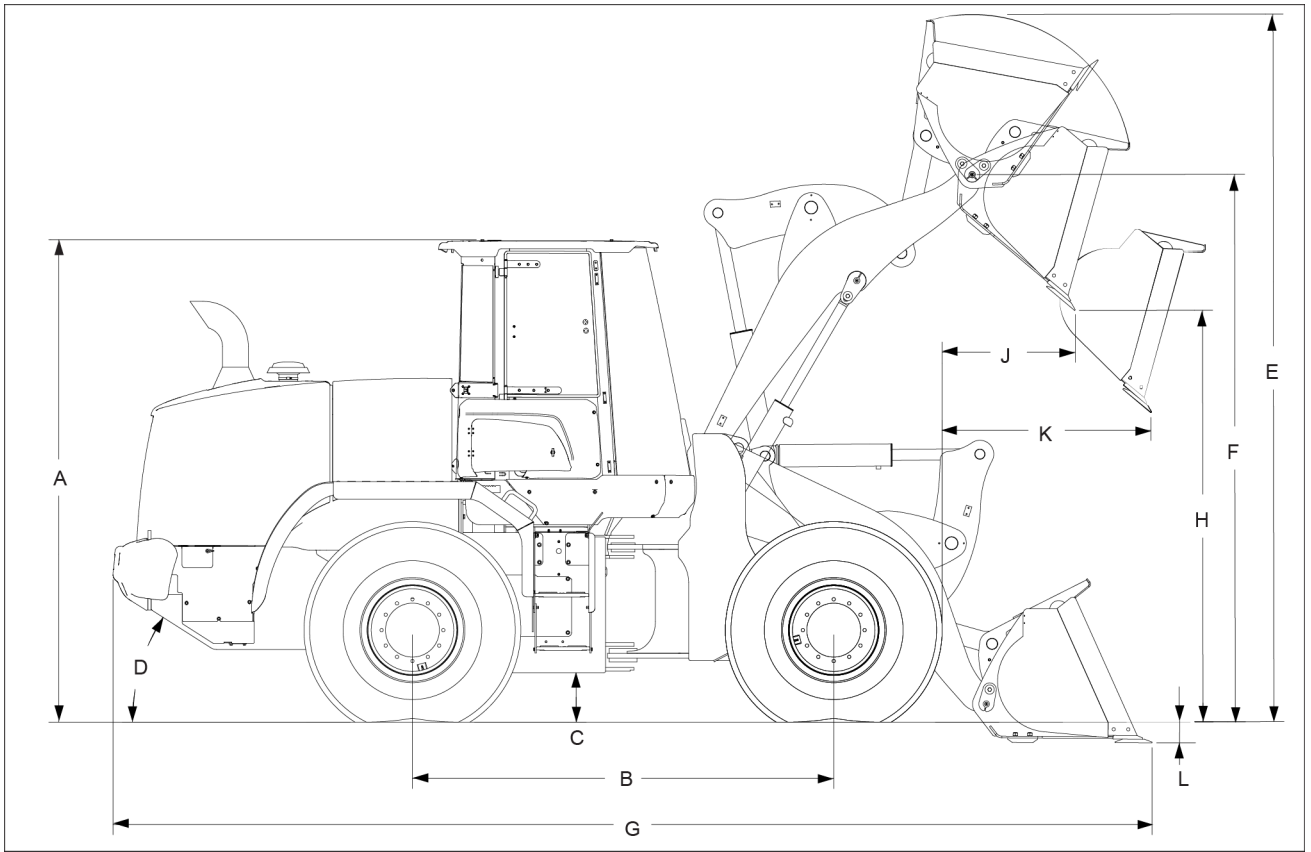

LEIL16WHL0629FB 18

921G Z-Bar Specifications - 3.1 m³ (4.0 yd³) Blade / 2.9 m³ (3.8 yd³) Teeth with JRB Coupler

	Bucket with Bolt-on Edge	Bucket with Teeth
ISO Bucket Specifications		
Capacity (heaped)	3.06 m³ (4.00 yd³)	2.91 m³ (3.80 yd³)
Bucket width (maximum outer)	3030 mm (119.3 in)	3027 mm (119.2 in)
Dimensional Outline Specifications		
A (top of cab height)	3463 mm (136.3 in)	3463 mm (136.3 in)
B (wheelbase)	3340 mm (131.5 in)	3340 mm (131.5 in)
C (ground clearance)	435 mm (17.1 in)	435 mm (17.1 in)
D (rear angle of departure)	29°	29°
Overall width w/o bucket	2829 mm (111.4 in)	2829 mm (111.4 in)
Centerline tread width	2230 mm (87.8 in)	2230 mm (87.8 in)
Turning radius (outside of tires)	6003 mm (236.3 in)	6003 mm (236.3 in)
Turning angle from center	40°	40°
Total turning angle	80°	80°
E (fully raised with spillguard)	5641 mm (222.1 in)	5641 mm (222.1 in)
F (hinge pin - fully raised)	4123 mm (162.3 in)	4123 mm (162.3 in)
G (overall - bucket level on ground)	8337 mm (328.2 in)	8486 mm (334.1 in)
H (dump - fully raised, 45° dump)	2821 mm (111.1 in)	2725 mm (107.3 in)
J (reach - fully raised, 45° dump)	1295 mm (51.0 in)	1408 mm (55.4 in)
K (reach - 2.13 m (7.0 ft), 45° dump)	1810 mm (71.3 in)	1869 mm (73.6 in)
L (dig depth)	75 mm (2.9 in)	76 mm (3.0 in)
ISO Load Specifications		
Operating Weight (without load)	20941 kg (46166 lb)	20877 kg (46025 lb)
Operating load	5843 kg (12882 lb)	5933 kg (13079 lb)
Tipping load		
Machine straight	14728 kg (32471 lb)	14935 kg (32926 lb)
40° turn	11686 kg (25763 lb)	11865 kg (26158 lb)

CLICK HERE TO **DOWNLOAD** THE COMPLETE MANUAL

- Thank you very much for reading the preview of the manual.
- You can download the complete manual from: www.heydownloads.com by clicking the link below



- Please note: If there is no response to CLICKING the link, please download this PDF first and then click on it.

CLICK HERE TO **DOWNLOAD** THE COMPLETE MANUAL