

ORIGINAL INSTRUCTIONS

821F
921F
Tier 2
Wheel Loader

OPERATOR'S MANUAL

Part number 51422046
1st edition English
December 2017



CLICK HERE TO **DOWNLOAD** THE COMPLETE MANUAL

- Thank you very much for reading the preview of the manual.
- You can download the complete manual from: www.heydownloads.com by clicking the link below



- Please note: If there is no response to CLICKING the link, please download this PDF first and then click on it.

CLICK HERE TO **DOWNLOAD** THE COMPLETE MANUAL

- The machine is intended to be used under normal conditions for the applications described in this manual. If the machine is used for other purposes or in dangerous environments, for example in a flammable or explosive atmosphere, special safety regulations must be followed and the machine must be equipped for use in these environments.

2 - SAFETY INFORMATION

Safety rules and signal word definitions

Personal safety





This is the safety alert symbol. It is used to alert you to potential personal injury hazards. Obey all safety messages that follow this symbol to avoid possible death or injury.

Throughout this manual and on machine safety signs, you will find the signal words DANGER, WARNING, and CAUTION followed by special instructions. These precautions are intended for the personal safety of you and those working with you.

Read and understand all the safety messages in this manual before you operate or service the machine.

 DANGER indicates a hazardous situation that, if not avoided, will result in death or serious injury. The color associated with DANGER is RED.

 WARNING indicates a hazardous situation that, if not avoided, could result in death or serious injury. The color associated with WARNING is ORANGE.

 CAUTION indicates a hazardous situation that, if not avoided, could result in minor or moderate injury. The color associated with CAUTION is YELLOW.

FAILURE TO FOLLOW DANGER, WARNING, AND CAUTION MESSAGES COULD RESULT IN DEATH OR SERIOUS INJURY.

Machine safety

NOTICE: Notice indicates a situation that, if not avoided, could result in machine damage or property damage. The color associated with Notice is BLUE.

Throughout this manual you will find the signal word Notice followed by special instructions to prevent machine damage or property damage. The word Notice is used to address practices not related to personal safety.

Information

NOTE: Note indicates additional information that clarifies steps, procedures, or other information in this manual.

Throughout this manual you will find the word Note followed by additional information about a step, procedure, or other information in the manual. The word Note is not intended to address personal safety or property damage.

Seat belts

⚠ WARNING

Roll-over hazard!

Securely fasten the seat belt. Your machine is equipped with a Roll-Over Protective Structure (ROPS) cab, ROPS canopy, or ROPS frame for your protection. The seat belt can help ensure your safety if it is properly used and maintained. Never wear a seat belt loosely or with slack in the belt system. Failure to comply could result in death or serious injury.

W0143A

1. Insert the metal end of the right-hand belt strap into the latch mechanism on the left-hand side of the seat.
2. Tighten the seat belt by pulling on the loose end of the right-hand seat belt.

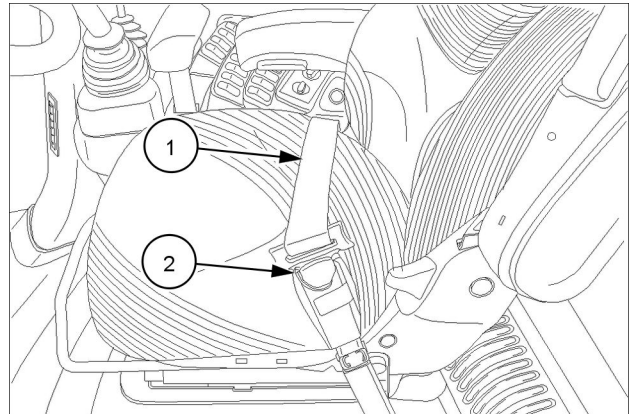

RCPH10WHL090BAL 1

1. Right-hand belt strap
2. Latch mechanism

1. To unlatch the seat belt, press the red button on the left-hand side mechanism.

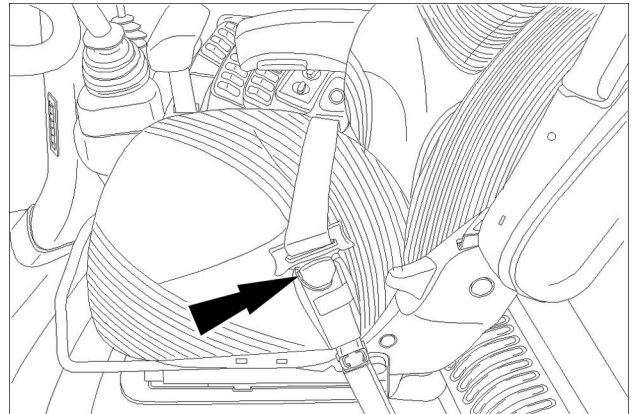

RCPH10WHL090BAL 2

Empty tool

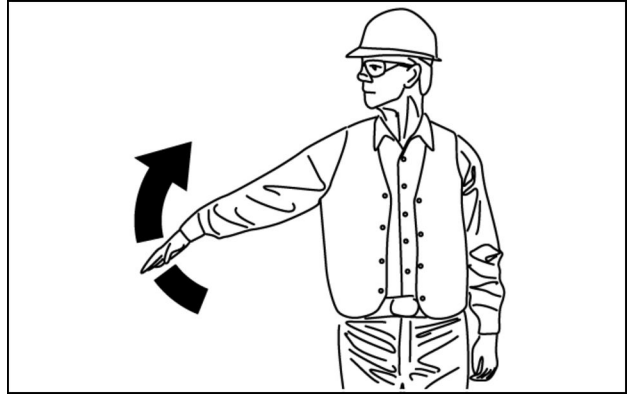

LEEN11T0024AA 20

Maintenance decal

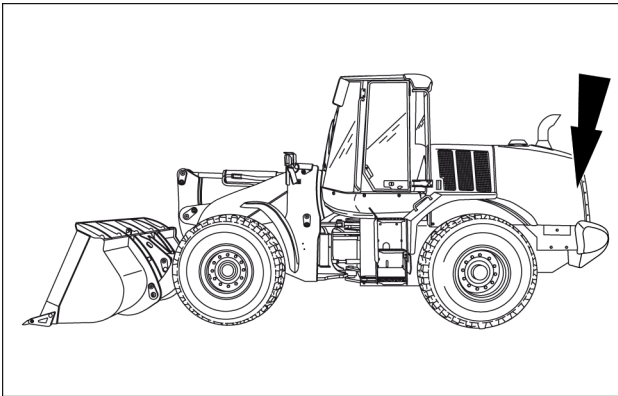

LEIL15WHL0065AA 34

Engine compartment - fan guard
 Informational decal - maintenance intervals
 ISO decal number: 48014400

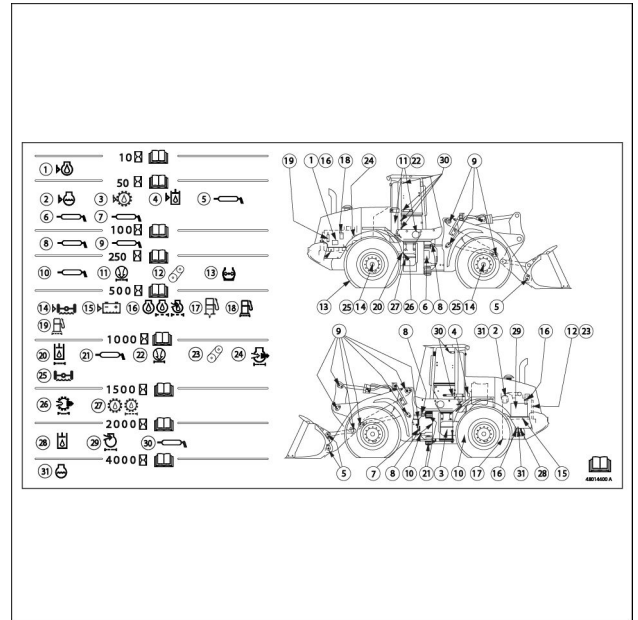

48014400 36

Entanglement hazard

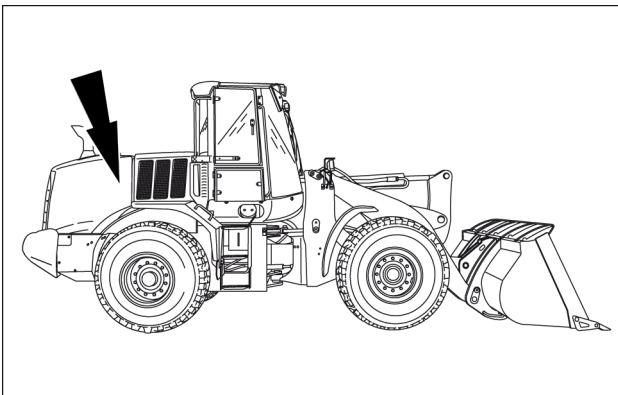

LEIL15WHL0066AA 36

Engine compartment - right side
 Warning - Entanglement hazard
 ISO decal number: 87488609



87488609 37

Optional air ride seat

1. Lumbar adjustment knob - Turn the knob clockwise to increase the lumbar support. Turn the knob counter-clockwise to decrease the lumbar support.
2. Armrest height control adjustment - Turn the knob to raise or lower the armrest to the desired position.

NOTE: each armrest will pivot to the up position.

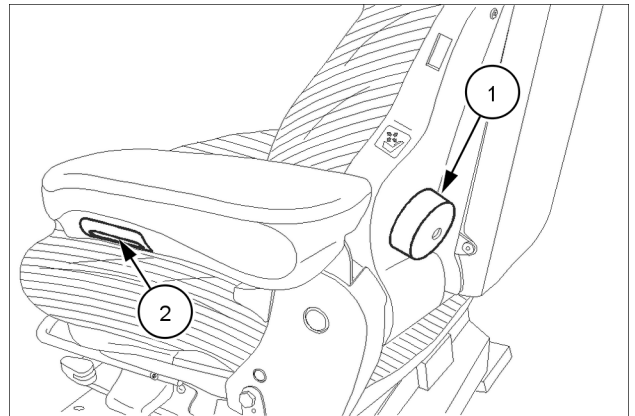

RCPH10WHL091BAL 6

3. Recliner adjustment handle - Lift up the handle, move the backrest to the desired position, release the handle to lock in position.

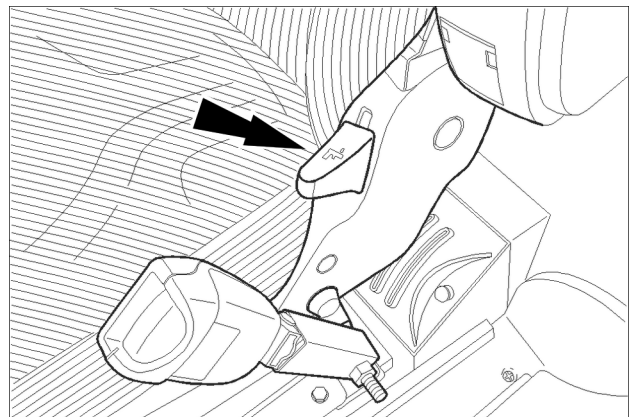

RCPH10WHL084BAL 7

4. Slide adjustment lever - Pull the slide adjustment lever up and adjust the seat forward or backward as required. Release the lever to lock the seat in position. Always make adjustments from the front center of the adjustment bar.

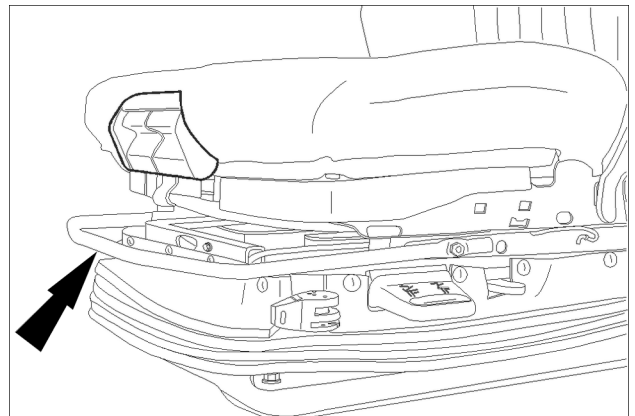

RCPH10WHL092BAL 8

Hydraulic control transmission Forward-Neutral-Reverse (FNR) operation

The F-N-R function of the transmission control lever may be moved to the loader control lever for operating efficiency.

All the following steps are required to use the control lever transmission shift functions:

1. Service brake pressure must be at operating temperature.
2. Left side F-N-R of transmission control lever must be in neutral.
3. Right side F-N-R switch must be in neutral.
4. Machine speed must be zero.
5. Engine must be running.
6. Push down on the top of the transmission enable switch located on the side console. The indicator light on the bottom of the enable switch will illuminate when activated.
7. Push down on the bottom of the parking brake switch to release the parking brake. This must occur within 8 seconds of enable. (If the parking brake was NOT set when the machine was turned off, the parking brake switch must be cycled at this step).
8. Place the right side F-N-R switch in either Forward or Reverse to move the machine. This must occur within 8 seconds of enable.

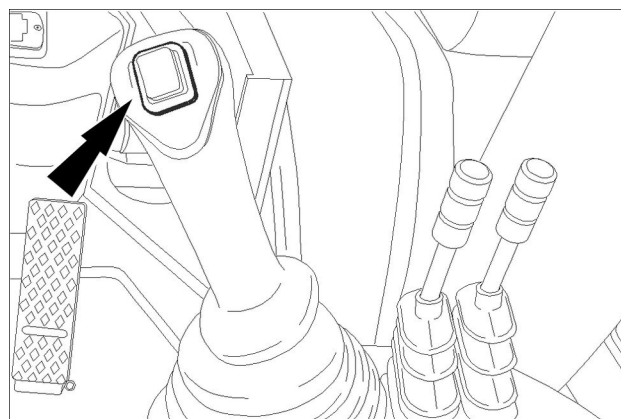

RCPH10WHL109BAL 2

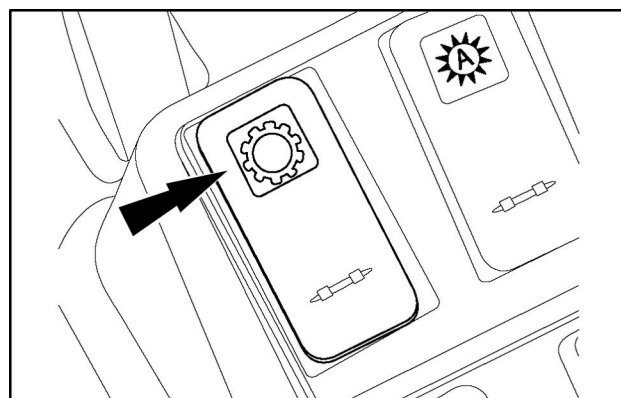

RCIL10WHL177BAL 3

Three function valve

Three function valve - two control levers

1. LIFT ARM AND BUCKET CONTROL

- A. DUMP
- B. ROLLBACK
- C. HOLD - The loader arms and bucket will not move when the control lever is in the HOLD position. The control lever will automatically return to the HOLD position when released. You must manually move the control lever from the FLOAT position to the HOLD position.
- D. FLOAT (DETENT) - This is a detent position. When in the FLOAT (detent) position, the loader bucket can follow the level of the ground without movement of the control lever
- E. LOWER
- F. RAISE

2. AUXILIARY CONTROL

- G. AUXILIARY FUNCTION
- H. AUXILIARY FUNCTION

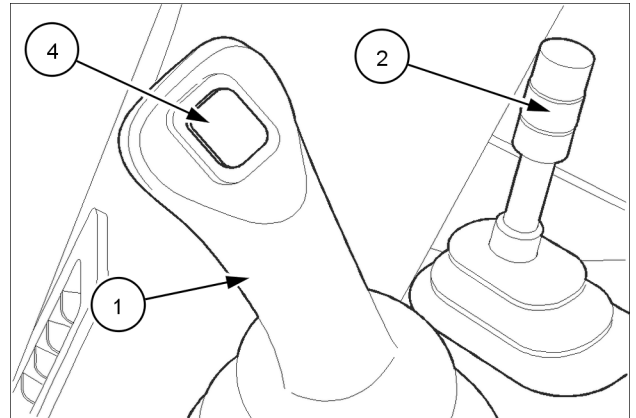

RCPH10WHL119BAL 1

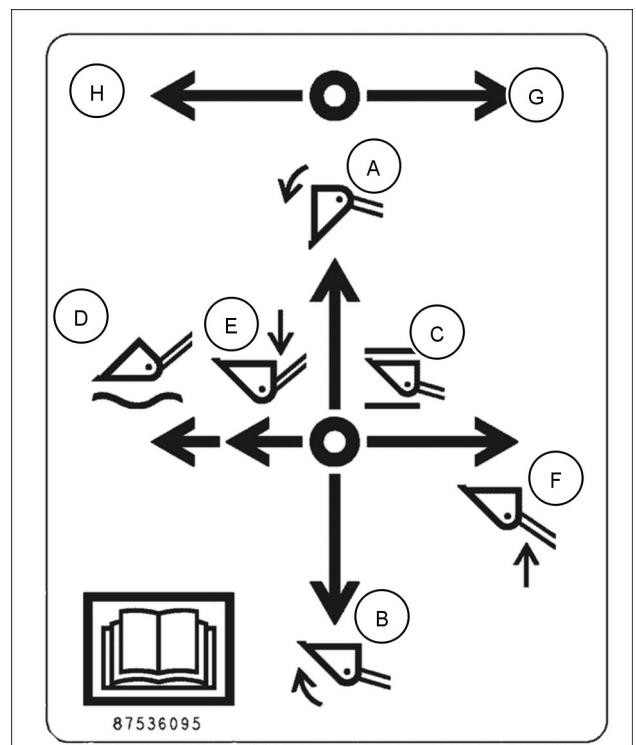

RCPH10WHL010AAL 2

INSTRUMENT CLUSTER

Overview

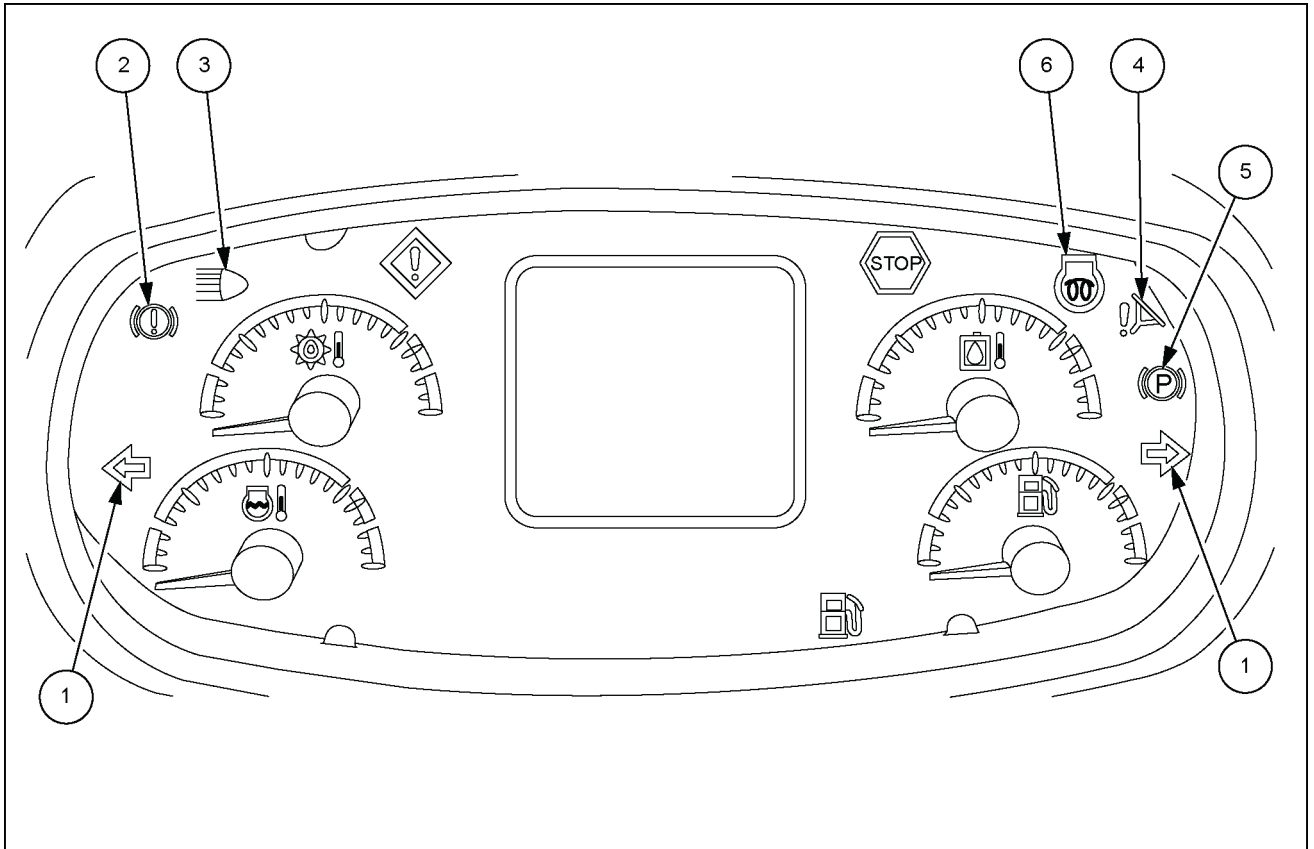

LEIL14WHL0494FB 1

Instrument panel indicators

The instrument cluster will check each monitored system when you turn the key switch to the ON position. All LED's (Light Emitting Diodes) will illuminate, and the warning alarm will sound for three seconds. At the end of this check all monitored systems will return to normal operation. If there is an open circuit between a sensor and the instrument cluster on some circuits, the LED will flash and the warning alarm will sound for **5 s**.

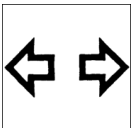

1. Four-way flasher and turn signal indicator

The indicator lamps will flash when a turn is signaled or when the four-way flashers are activated.



2. Brake pressure indicator

The indicator illuminates when the brake system pressure is too low. The alarm sounds continuously, and the stop master indicator will be red. Stop the machine, and correct the problem.



3. Lamp indicator

The indicator illuminates when the driving high beam lamps are ON.

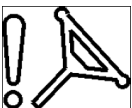

4. Secondary steering (if equipped)

This indicator illuminates when the primary steering system pressure is too low. The alarm sounds continuously and the stop master indicator turns red.

If this situation occurs, stop the machine immediately and contact your dealer.

Push the down key again to display the Info 4 screen. This screen displays voltage, the temperature in Fahrenheit or Celsius of the turbocharger air.

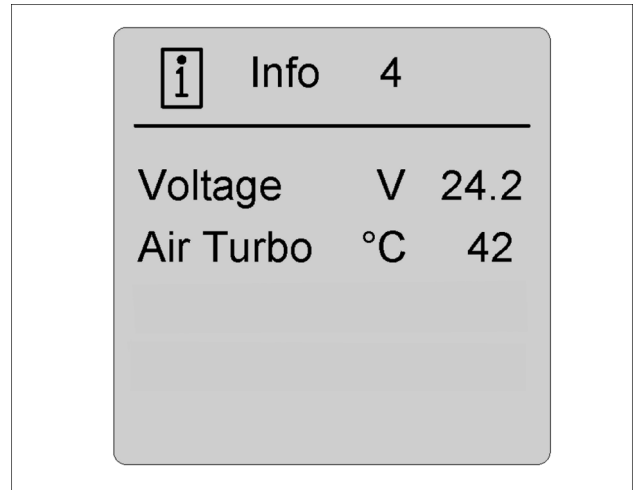

RCPH10WHL352AAH 6

Press the down key again and the Trip 1 screen will display. The LCD provides two trip computers. These will display since last reset the total time in hours, the total fuel, and the average fuel consumption per hour.

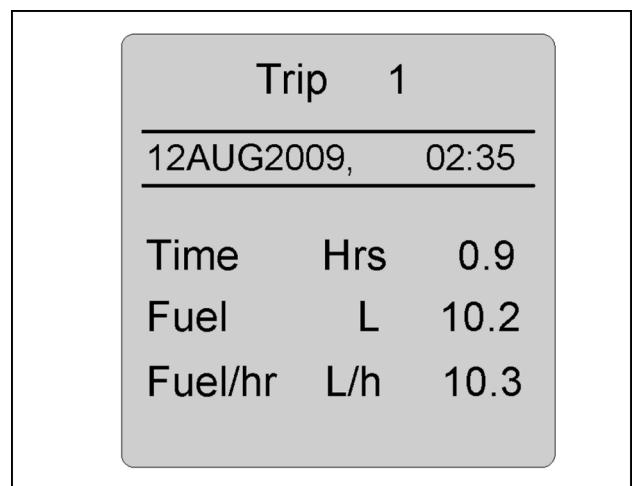

RCPH10WHL353AAH 7

By continuing to scroll down, the sixth screen will display the Trip 2 screen. Trip 1 and Trip 2 screens can be reset independently.

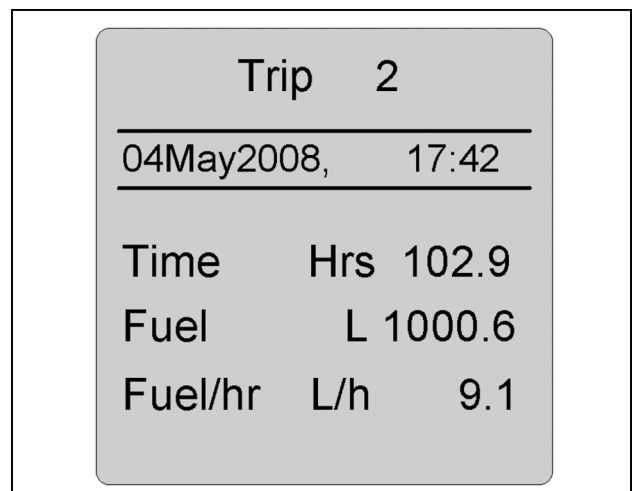

RCPH10WHL354AAH 8

Fan auto (if equipped)

In automatic mode, the fan speed will switch between high, low, or reverse as conditions require. This will depend upon the system temperature. To select the fan mode, highlight the Fan Auto selection on the "Eng Options" screen, then press the confirm key. Scroll through the fan choices, highlight the desired selection and press the confirm key to lock into memory. Use the escape key to return to the main driving menu. The steps will only apply if the machine is equipped with the auto fan feature.

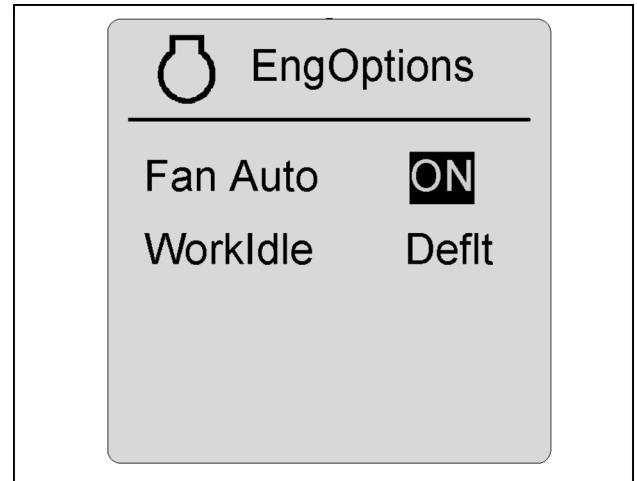

RCPH10WHL373BAH 8

Auto idle (if equipped)

The auto idle feature has three settings that control the engine low idle speed. This feature only applies when the wheel loader is stationary, in neutral, and not under load. The OFF setting will keep the low idle speed constant at the factory setting independent of engine or ambient temperature. The LOW setting will allow the low idle speed to decrease below the factory setting. By reducing the low idle speed, fuel consumption will be reduced. The ACCELERATED setting will allow the low idle speed to increase above the factory setting. Increasing the low idle speed helps at warm-up and can improve air conditioning performance. To change the auto idle setting, highlight the "Auto Idle" selection, then press confirm. This will allow you to scroll through the idle choices. Highlight the selection desire, and lock the selection into memory by pressing the confirm key, and then return to the main menu driving screen with the escape key.

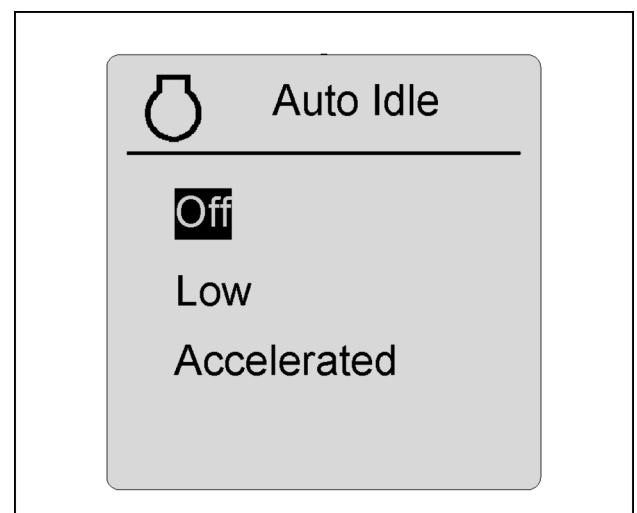

RCPH10WHL371BAH 9

NOTE: If the wheel loader is shifted out of neutral, put under any load, or if the temperature limits are not met, the idle will default to the standard factory set idle speed.

14. Height control switch



Push on the top of the function switch for the ON position. This will allow the bucket to be raised to set height position when activated.

15. Ride control switch (if equipped)



This is a 3-position switch. Push on the top of the switch for the manual ON position. Ride control can be left on at all times, whether loading or traveling on road. The center position is the automatic and most commonly used position. In the automatic position, ride control will automatically activate when ground speed is above **5 km/h (3.1 mph)** and automatically shut off when ground speed is below **5 km/h (3.1 mph)**. The indicator light on the switch will illuminate when ride control is activated. To turn ride control off, push on the bottom of the function switch for the OFF position.

STARTING THE UNIT

Starting the engine

▲ WARNING

IMPROPER OPERATION OF THIS MACHINE CAN CAUSE DEATH OR SERIOUS INJURY.

MAKE SURE THAT EVERY OPERATOR:

- is instructed in the safe and proper use of this machine.
 - reads and understands the operator's manual for this machine.
 - reads and understands **ALL** safety signs on the machine.
- Failure to comply could result in death or serious injury.

W0188A

Before operating the machine

Before operating this machine, complete the following procedures:

1. Check the level of all fluids (engine oil, fuel, hydraulic fluid, and coolant) and make sure that the fluids and lubricants are suitable for prevailing conditions.
2. Carry out the daily maintenance operations.
3. Inspect the machine, look for any signs of possible leakage and check the hoses. Tighten or replace as necessary.
4. See Run in period of a new machine in this chapter, if the machine is new or if the engine has been re-conditioned.
5. Check the tires for any visible damage. Replace or repair as necessary. Check for correct tire air pressure and adjust pressure if necessary.
6. Clean the steps and hand holds. Grease, oil, mud, or ice in winter on the steps and access handles can cause accidents. Make sure they are kept clean at all times.
7. Clean or replace any decals which are illegible. See Safety signs – Chapter 2.
8. Make sure that the engine access panels and all doors are properly closed and latched.
9. Secure the cab door in either fully closed or fully opened position.
10. Remove any obstructions which hinder visibility. Clean the windshield, the windows and the rear view mirrors.
11. Check that no tools or other items have been left on the machine or in the operator's compartment.
12. Make sure no one is on or under the machine. The operator must be alone on the machine.
13. Make sure no one is standing in the machine working area.
14. Find out about current safety measures in use on the work site.
15. Work out a convenient means of escape from the machine (emergency exit via the windshield, the rear or side window glass) in the event of the cab door being jammed or the machine turning over.
16. Before undertaking any travel or working operations during hours of darkness, make sure the lighting and signaling equipment is fully operative.
17. Adjust the seat so that you can apply the foot brakes when your back is against the seat backrest.
18. Fasten and adjust the seat belt.
19. With the engine running and at operating temperature, check the instrument panel for correct indications.
20. Check the loader controls for correct operation.

MOVING THE UNIT

Before operating the transmission

Transmission enable switch

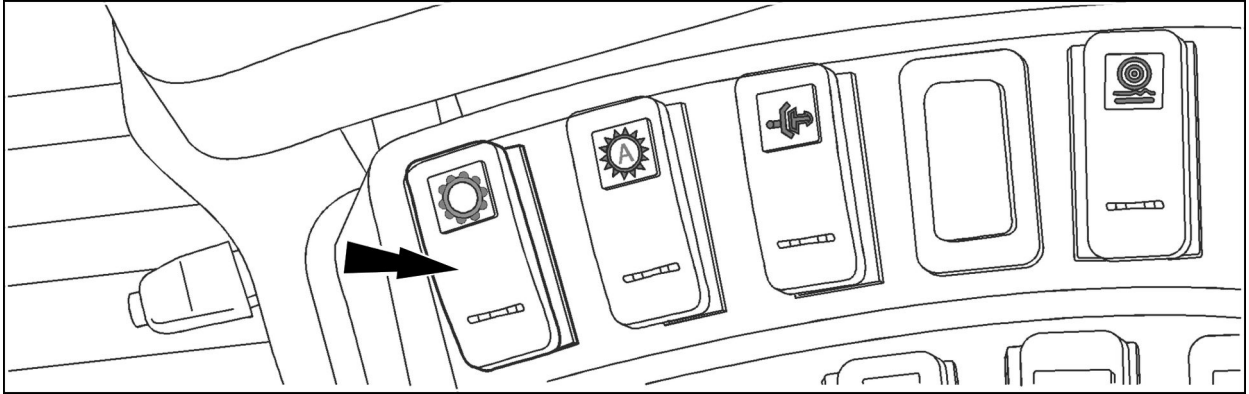

RCPH10WHL004EAL 1

You can enable the transmission enable switch after the following conditions have been completed:

1. The transmission controller is in NEUTRAL (left-hand side of the steering column).
2. The F-N-R switch is in NEUTRAL (right side).
3. The engine must be running.
4. The machine is stationary.
5. The parking brake is released.

Push the transmission enable switch to allow the selection of the F-N-R function on the joystick. The transmission enable switch lights up when activated.

NOTE: within **8 s** from the activation of the transmission enable switch, you must carry out the following actions must take place otherwise you must reactivate the F-N-R enable switch:

1. Release the parking brake switch.
2. Shift to FORWARD or REVERSE from the NEUTRAL position on the F-N-R switch.

If you move the transmission control lever from NEUTRAL or you stop the engine or you apply the parking brake, the auxiliary F-N-R mode is deactivated.

When steps 1 through 5 have been completed, you can press on the top of the transmission enable switch **(4)** and activate the transmission enable switch. The indicator light on the bottom of the switch will illuminate.

The transmission enable control will default back to the Standard transmission control lever if:

1. The engine is stopped.
2. The parking brake is applied.
3. The transmission control lever is taken out of the neutral position.

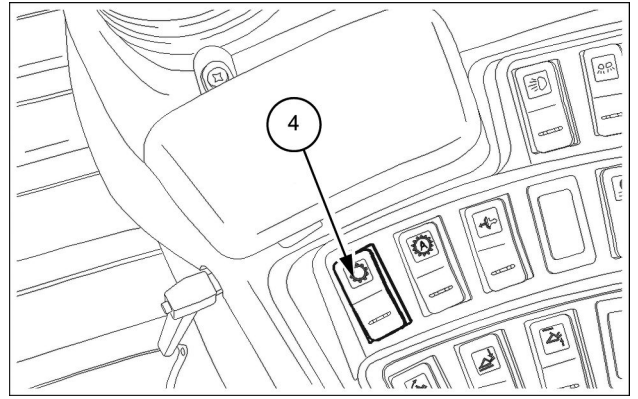

LEIL16WHL0130AB 8

Engine coolant heater (if equipped)

The left-hand side of the engine block has a connection for installing an optional coolant heater. See your authorized dealer for this cold weather option.

Bucket level indicator

The bottom of the bucket is parallel with the ground when the flat portion of the bucket is horizontal.

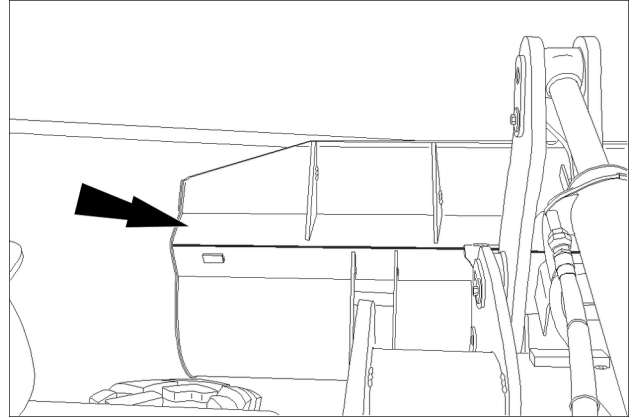

RCPH10WHL127BAL 16

CLICK HERE TO **DOWNLOAD** THE COMPLETE MANUAL

- Thank you very much for reading the preview of the manual.
- You can download the complete manual from: www.heydownloads.com by clicking the link below



- Please note: If there is no response to CLICKING the link, please download this PDF first and then click on it.

CLICK HERE TO **DOWNLOAD** THE COMPLETE MANUAL

Operating the machine in water

▲ WARNING

Driving hazard!

Do not operate the machine in a fast flowing stream. Fast flowing water can cause you to lose control of the machine.

Failure to comply could result in death or serious injury.

W0151A

- Make sure that the bottom of the stream, or water in which you will work, can support the weight of the machine.
- Do not allow the water level to reach the wheel rim.
- Before using the machine in water, inject large quantities of fresh grease into the appropriate grease fittings.
- After completing the operation make sure to inject fresh quantities of grease into any fitting that was in water.

Joystick steering armrest adjustment

The left-hand armrest equipped with optional joystick steering controls can be adjusted for operator comfort.

To adjust the height of the armrest, loosen the knob **(1)**. Lower or raise the armrest into the desired position, then retighten the knob.

To adjust the armrest forward or backward, loosen the knob **(2)**, then move the armrest back or forward until it reaches the desired position.

Retighten the knob once the adjustment is complete. For tilt adjustment, loosen the knob **(3)**, then tilt the armrest into the desired position. Retighten the knob once the adjustment is complete.

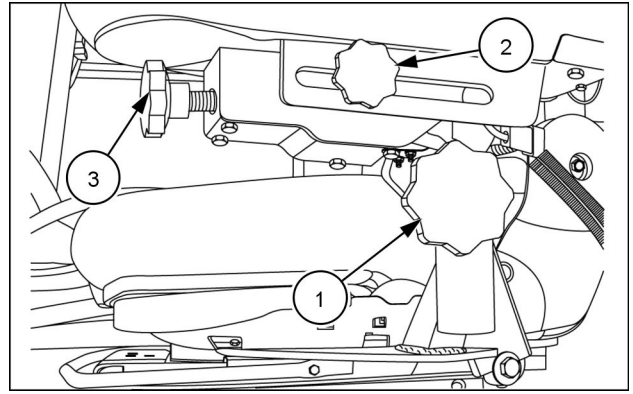

RCIL10WHL199BAL 2

Locking armrest in raised safety position

1. To lock the arm in the raised safety position, raise the arm to its vertical position. To block the armrest, raise the red pivot **(1)**.

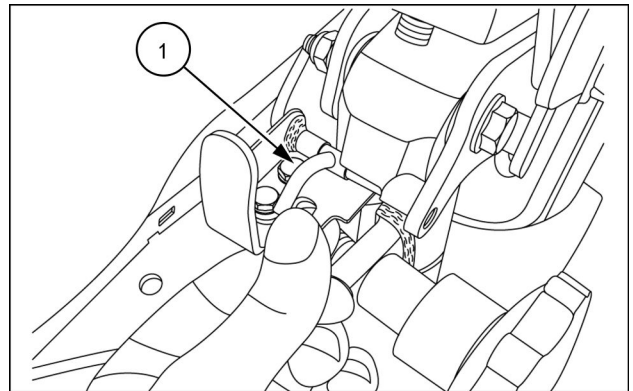

RCIL10WHL200BAL 3

2. Press the pivot **(1)** in the direction indicated by the arrow in the figure and insert it into detent **(2)**.

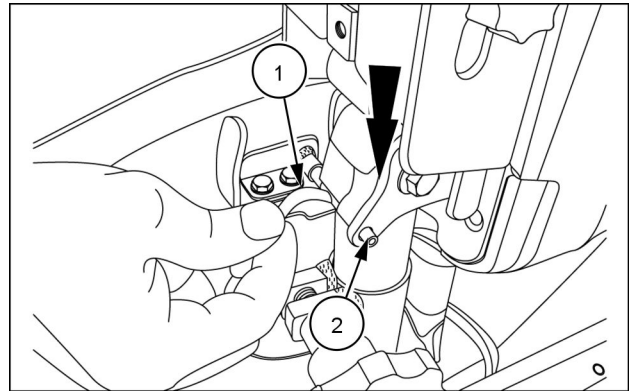

RCIL10WHL201BAL 4

3. Lower the pivot **(1)**. To unlock the armrest, pull the pivot **(1)** outward, then lower.

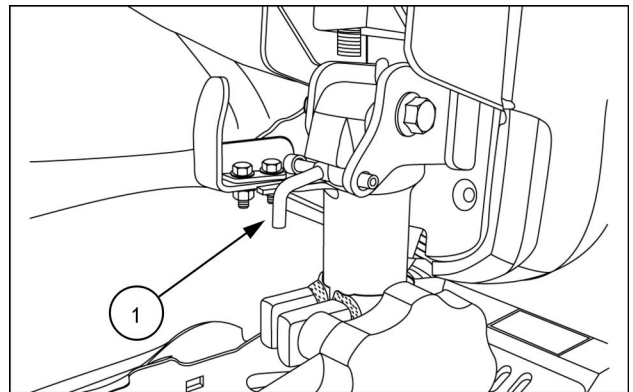

RCIL10WHL202BAL 5

Support strut for loader lift arm

Loader lift arm support

⚠ DANGER

Crushing hazard!

If you service the machine with the loader lift arms raised, always use the support strut. Remove the retaining pin and place the support strut onto the cylinder rod. Install the retaining pin into the support strut. Lower the lift arms onto the support strut.

Failure to comply will result in death or serious injury.

D0084A

1. Empty the loader bucket, raise the loader lift arms to approximately **2.1 m (7 ft)** and stop engine.
2. Remove the support strut from the storage position by removing the retaining bolt (1).
3. Place the support strut on to the cylinder rod with the guide lock tab on top of cylinder and pointing toward the bucket (2).
4. Install the retaining bolt entirely into the support strut using all threads (3).
5. Slowly lower the lift arms onto the support strut.

If you do not follow this procedure, you can cause death or serious injury if the loader lift arms are lowered unexpectedly.

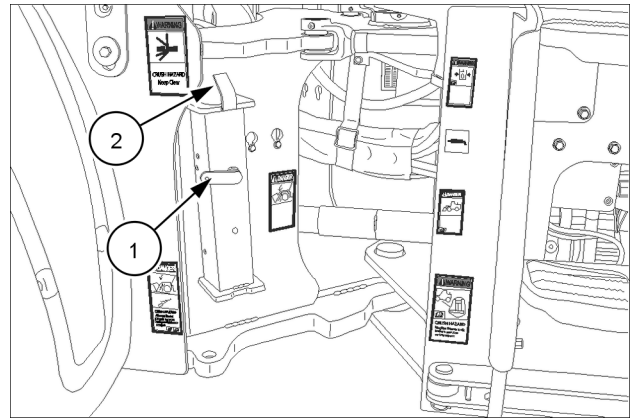

RCPH10WHL059BAL 1

NOTE: Support strut in transport position.

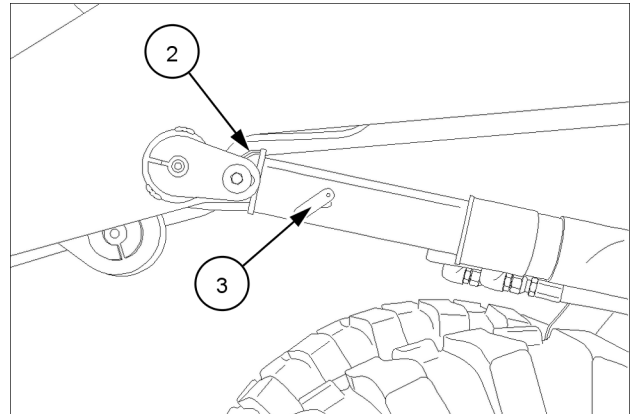

RCPH10WHL061BAL 2

NOTE: Support strut in service position.

Fuel

Use diesel fuel suitable for the ambient temperature conditions (ASTM-D-975).

Use fuel which is to ASTM (American Society for Testing and Materials) D975 standard.

Use grade No. 2 fuel. The use of other types of fuel can result in a loss of power of the engine and may cause high fuel consumption.

In very low ambient temperatures, use a mixture of fuels No. 1 and No. 2 as necessary. Consult your fuel supplier for appropriate fuel supply.

If the temperature falls below the fuel cloud point (point at which wax begins to form) the wax crystals will cause power loss or will prevent the engine from starting.

In cold weather, fill the fuel tank at the end of the day's work in order to prevent the formation of condensation.

Fuel storage

Prolonged storage of fuel can lead to the accumulation of impurities and condensation in the fuel. Engine trouble can often be traced to the presence of water in the fuel.

The storage tank must be placed outside and the temperature of the fuel should be kept as low as possible. Drain off water and impurities regularly.

Hydraulic fluid

CASE AKCELA HY-TRAN® ULTRACTION meets the CNH material specification MAT 3540 and is specifically designed for high pressure applications and for CASE CONSTRUCTION hydraulic systems. Your CASE CONSTRUCTION dealer can provide hydraulic fluid to fulfill different climate/temperature conditions. Refer to the charts at the beginning of this section.

Transmission component oil

Extreme pressure oil should be used for enclosed transmission components. Choose an oil that is manufactured for your climate/temperature conditions such as **CASE AKCELA NEXPLORE™ FLUID**. See the charts at the beginning of this section.

Front and rear axle oil

Extreme pressure oil must be used for enclosed transmission components. Choose an oil that is manufactured for your climate/temperature conditions such as **CASE AKCELA TRANSAXLE FLUID 80W-140**. See the charts at the beginning of this section.

Every 10 hours**Engine oil level - Check**

Service specifications	
Type of oil	CASE AKCELA UNITEK 10W-40
821F Capacity (with filter change)	13.25 l (14.0 US qt)
921F Capacity (with filter change)	13.25 l (14.0 US qt)

Check the engine oil level every 10 hour shift or each day, whichever occurs first.

The engine oil dipstick (1) is located on the right-hand side of the engine, above the fuel fill location.

1. Keep all non-authorized personnel clear of the area. Park the machine on a firm, level surface and turn off the engine. Remove the dipstick to check the engine oil level. Wipe the dipstick clean and reinsert. The oil level should register at the full mark.

NOTE: this procedure is best performed at the beginning of the work day with the engine cool and all oil drained to the pan

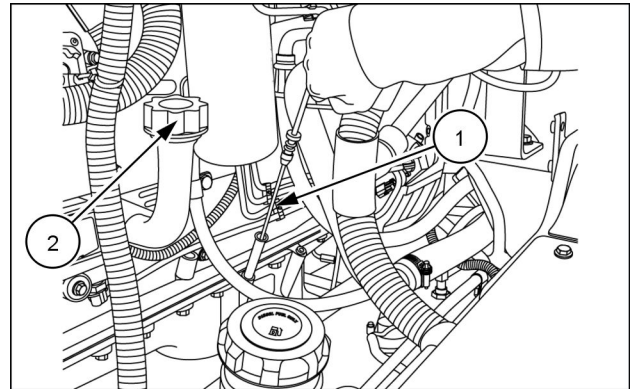

RCPH10WHL899AAH 1

2. Locate the fill location (2) in the main engine compartment. Add **CASE AKCELA UNITEK 10W-40**, if necessary. Do not overfill engine oil.

6. Fill the axle with new **CASE AKCELA TRANSAXLE FLUID 80W-140** at axle ends. The oil should reach the bottom of the fill plug.

NOTE: the oil will take some time to fill each axle. Allow time for the oil to circulate throughout the axle.

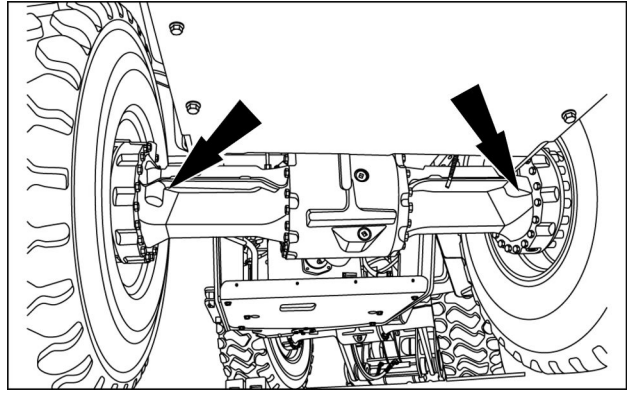

RCPH10WHL081AAH 3

Every 250 hours

Drive shaft slip joints - Grease

Machine grease fittings

Service specifications	
Grease Specification	CASE AKCELA MOLY GREASE

Grease the drive shaft slip joints when the hourmeter registers 250 or more often if conditions so require.

Clean around the area to be greased before service.

NOTICE: In severe conditions, such as immersion in water, it may be necessary to reduce the greasing service intervals.

Drive shaft slip joint

The grease zert is located on the drive shaft. Park the machine so the zert is accessible.

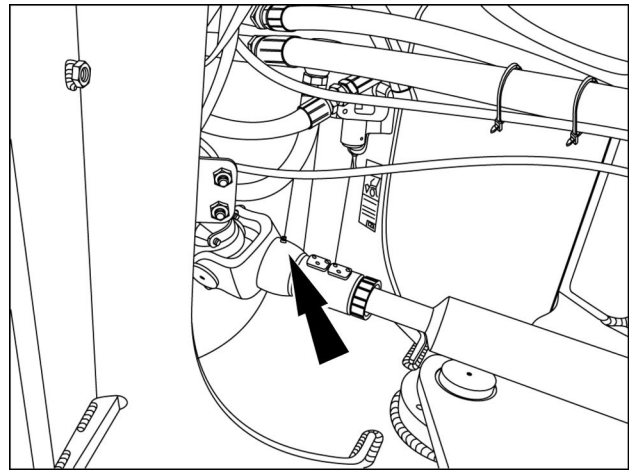

RCPH10WHL456AAH 1

Fuel pre-filter - Replace

⚠ WARNING

Fuel vapors are explosive and flammable.

Do not smoke while handling fuel. Keep fuel away from flames or sparks. Shut off engine and remove key before servicing. Always work in a well-ventilated area. Clean up spilled fuel immediately. Failure to comply could result in death or serious injury.

W0904A

Prior operation:

Park the machine on a firm, level surface. Lower the attachment to the ground. apply the parking brake, and install the transport service link to prevent unexpected articulation.

Drain fuel prefilter condensation

1. Change the fuel prefilter when the machine hourmeter registers 500 hours. Change filter every 500 hours thereafter or more often if conditions so require or if fuel quality is poor. The prefilter is located on the right side of the machine.
2. Remove connector. Open the drain valve on the fuel prefilter by turning counterclockwise two or three turns. Drain the water and/or contaminants from the prefilter into a suitable container until clean fuel flows. Do not allow fuel to spill on engine or ground.
3. Turn the filter counterclockwise to remove.
4. Replace with a new filter cartridge, turning clockwise until the cartridge meets the filter head. Hand tighten firmly in place. Do not use a wrench to tighten. Replace connector at bottom of filter.

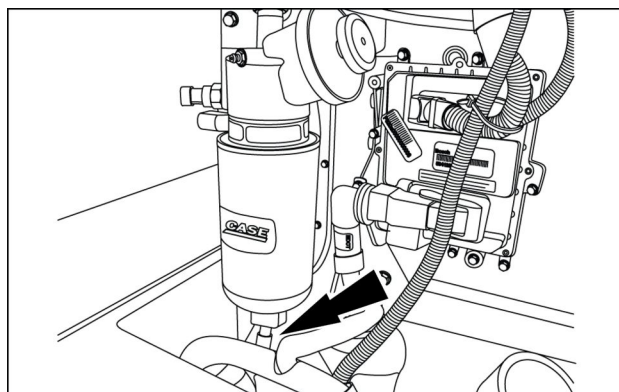

RCPH10WHL114AAH 1

Articulation fittings - Grease

⚠ WARNING

Avoid injury! Always do the following before lubricating, maintaining, or servicing the machine.

- 1. Disengage all drives.**
- 2. Engage parking brake.**
- 3. Lower all attachments to the ground, or raise and engage all safety locks.**
- 4. Shut off engine.**
- 5. Remove key from key switch.**
- 6. Switch off battery key, if installed.**
- 7. Wait for all machine movement to stop.**

Failure to comply could result in death or serious injury.

W0047A

1. Keep all non-authorized personnel clear of the area. Park the machine on level ground, in neutral with the parking brake applied and the attachment lowered to the ground.
2. Place the transport/service link into the lock position to stop unexpected articulation of the machine.
3. Clean the area around each fitting and grease.

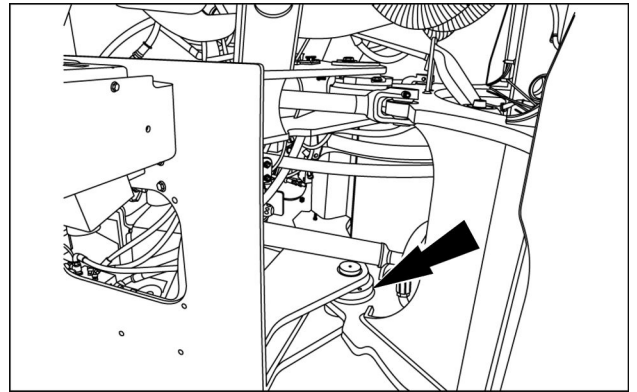

RCPH10WHL145AAH 1

7. Remove the filter.
8. Apply a film of clean **CASE AKCELA NEXPLORE™ FLUID** to the gasket of the new filter and install. Make sure that the proper contact is made with the base.
9. Clean the transmission breather and reinstall. See the transmission breather cleaning procedure. Refill with clean **CASE AKCELA NEXPLORE™ FLUID**.
10. Check the oil level at the sight gauge.
11. Start the engine and check for oil leaks around the filter and drain plug.
12. Bring the transmission oil up to working temperature, and check the level again.

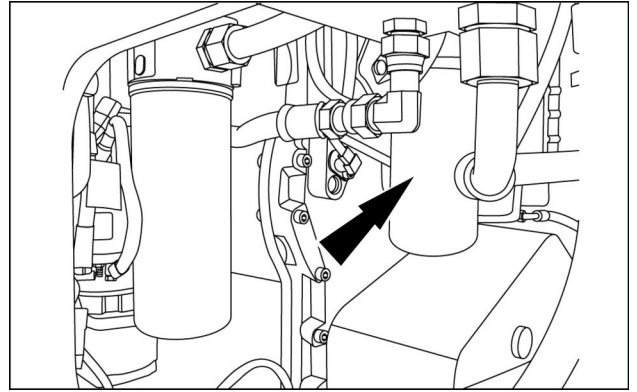

RCPH10WHL127AAH 2

Every 4000 hours

Engine coolant - Change

⚠ WARNING

Burn hazard!

Hot coolant can spray and scald if you remove the radiator or deaeration tank cap while the system is hot. To remove the cap: allow the system to cool, turn the cap to the first notch, and wait for all pressure to release. Remove the cap only after all pressure has released.

Failure to comply could result in death or serious injury.

W0367A

⚠ WARNING

Rotating parts!

The engine is running. Keep clear of rotating fans and belts.

Failure to comply could result in death or serious injury.

W0275A

Drain, flush and replace the engine coolant every 4000 hours of operation or each year, whichever occurs first. Clean the system and replace the coolant if it becomes dirty or is rust colored.

Service specifications	
Type of coolant	CASE AKCELA ACTIFULL™ OT EXTENDED LIFE COOLANT
821F Capacity	30.0 l (7.9 US gal)
921F Capacity	32 l (8.5 US gal)

1. After the engine has cooled and the temperature of the coolant has reached a safe level, remove the cap of the engine radiator on the left-hand side.

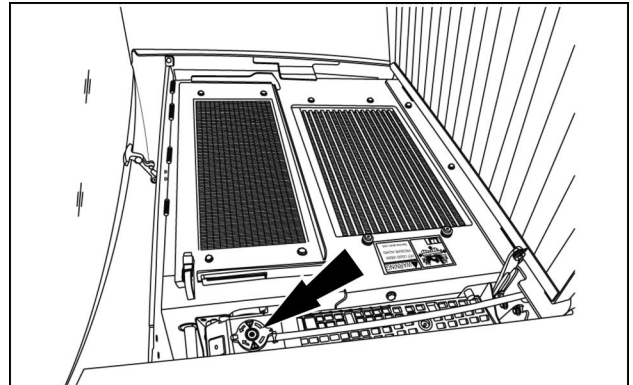

RCPH10WHL139AAH 1

2. With a suitable container of the proper capacity under the drain, open the cap by turning counterclockwise and drain the coolant from the system.
3. After all the coolant is drained, secure the drain cap.
4. Use a system cleaning product to clean and flush the system. Contact your Dealer for system cleaning products.
5. After the system has been cleaned and flushed following the cleaning product instructions, close and secure the drain valve.

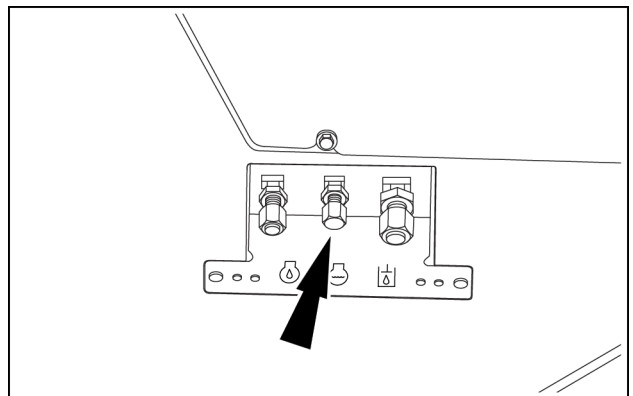

LEIL16WHL0198AA 2

5. Follow the prompts on the screen to complete the park brake test. If all conditions are not met to test the brake, the monitor will display the condition that must be corrected prior to completion of the test. The parking brake must be engaged.
6. Make sure all conditions are met. The monitor will display: Test Park Brake Ready
7. Shift the gear selector into third gear forward, and slowly increase the engine speed to full open throttle.
8. Verify that the machine does not move.
9. Reduce engine speed to low idle, and return the transmission to neutral.
10. Shift the gear selector to third gear reverse and slowly increase the engine speed to wide open throttle.
11. Verify that the machine does not move.
12. Reduce the engine speed to low idle and return the transmission to neutral.
13. Press the escape key on the key pad to exit the test mode.

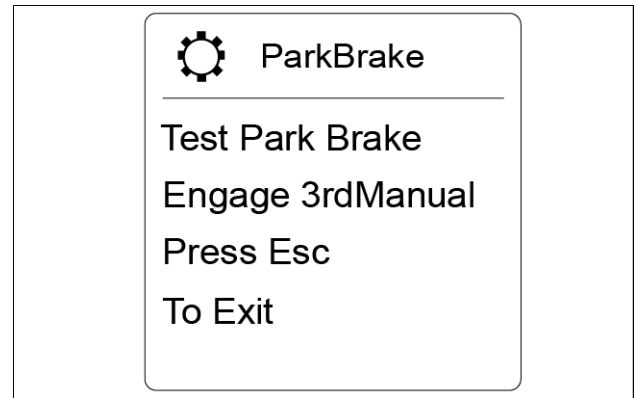

LEIL16WHL0125AA 3

Cleaning the batteries

Check the batteries and battery compartment regularly for dirt, corrosion and damage. Dirt mixed with electrolyte or moisture on the top of the batteries can cause a discharged condition in the batteries. Use one of the following methods to clean the batteries.

- Use CASE CONSTRUCTION Battery Saver. Follow the instructions on the container. This cleaner does not need water.

Use baking soda or ammonia and flush the outside of the batteries with water. If you do not have CASE CONSTRUCTION Battery Saver, use other special cleaners to prevent corrosion on the battery terminals.

Battery recycling

Batteries and electric accumulators contain several substances that can have a harmful effect on the environment if they are not properly recycled after use. CASE CONSTRUCTION strongly recommends that you return all used batteries to a CASE CONSTRUCTION dealer who will dispose of or recycle them properly. In some countries, this is a legal requirement.

Alternator

Service specification	
Check	Every 1000 hours

Ask your dealer to check the alternator.

Do not use steam cleaning equipment or a cleaning solvent to clean the alternator.

Starter motor

Service specification	
Check	Every 1000 hours

Ask your dealer to check the starter motor.

Make sure that the terminal protectors are correctly installed.

Lights - Replace

1. Work lights
2. Driving lights
3. Tail lights

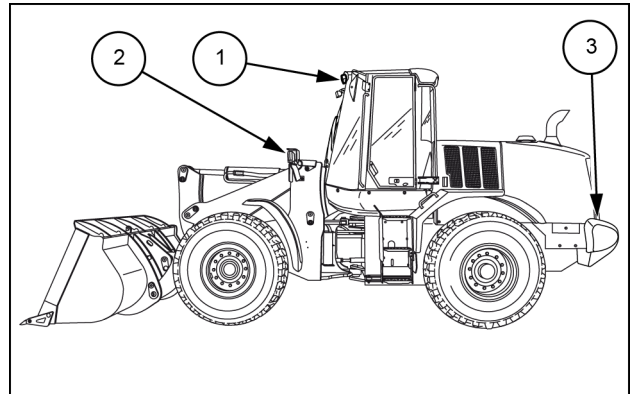

LEIL13WHL0324AB 1

Work lights

To replace the work lights, remove the Phillips screws from the front of the light. Disconnect the push-on connectors, and replace the lamp assembly. Reconnect the push-on connectors. Make sure that the connections are firmly in place. Replace the lamp assembly, and secure the frame with the Phillips screws.

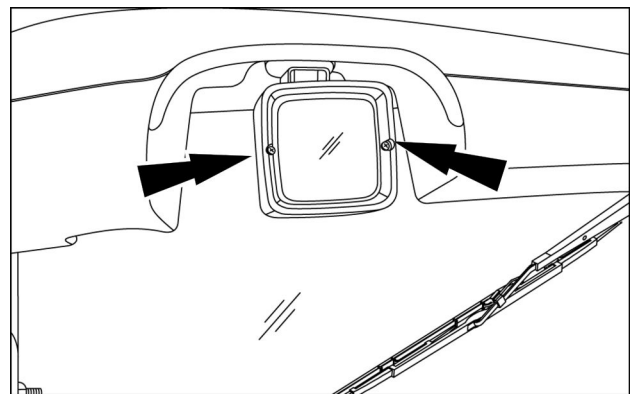

RCPH10WHL501AAH 2

Two light bar work lights (optional)

The optional two work light configuration lamps can be serviced individually. Follow the same procedure as the standard work light assembly.

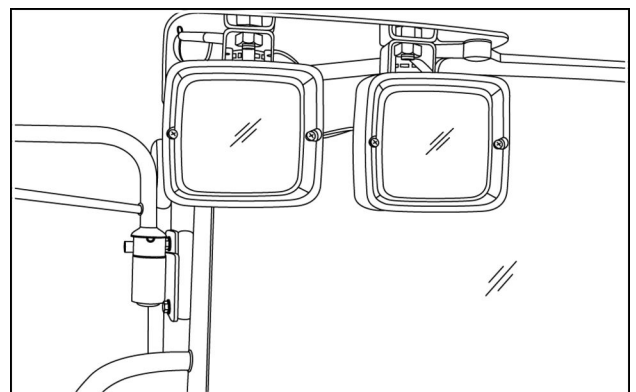

RCPH10WHL503AAH 3

921F Model**921F Engine Specifications**

Model	FPT F4HFA613D, Tier 2 certified
Type	4-stroke, turbocharged, air-to-air cooled
Cylinders	6
Bore / Stroke	104 mm (4.09 in) x 132 mm (5.20 in)
Displacement	6.7 l (411 in³)
Fuel Injection	Electronic
Horsepower (peak)	
Maximum power	
Gross	190 kW (255 Hp) @ 1600 RPM
Net	180 kW (242 Hp) @ 1600 RPM
Standard power	
Gross	169 kW (226 Hp) @ 1600 RPM
Net	159 kW (213 Hp) @ 1600 RPM
Economy power	
Gross	160 kW (215 Hp) @ 1400 RPM
Net	154 kW (206 Hp) @ 1400 RPM
Torque (maximum)	
Maximum power range	
Gross	1300 N·m (959 lb ft) @ 1300 RPM
Net	1261 N·m (930 lb ft) @ 1300 RPM
Standard power range	
Gross	1123 N·m (828 lb ft) @ 1300 RPM
Net	1084 N·m (800 lb ft) @ 1300 RPM
Economy power range	
Gross	1123 N·m (828 lb ft) @ 1300 RPM
Net	1084 N·m (800 lb ft) @ 1300 RPM
Economy engine speeds (4 speed and 5 speed transmissions)	
Machine idled (alternate low idle)	670 – 730 RPM
Machine idled (cold weather alternate accelerated low idle)	1270 – 1330 RPM
Electrical	
Batteries	2 - 12 V
Alternator	120 A
Voltage	24 V

8 - SPECIFICATIONS

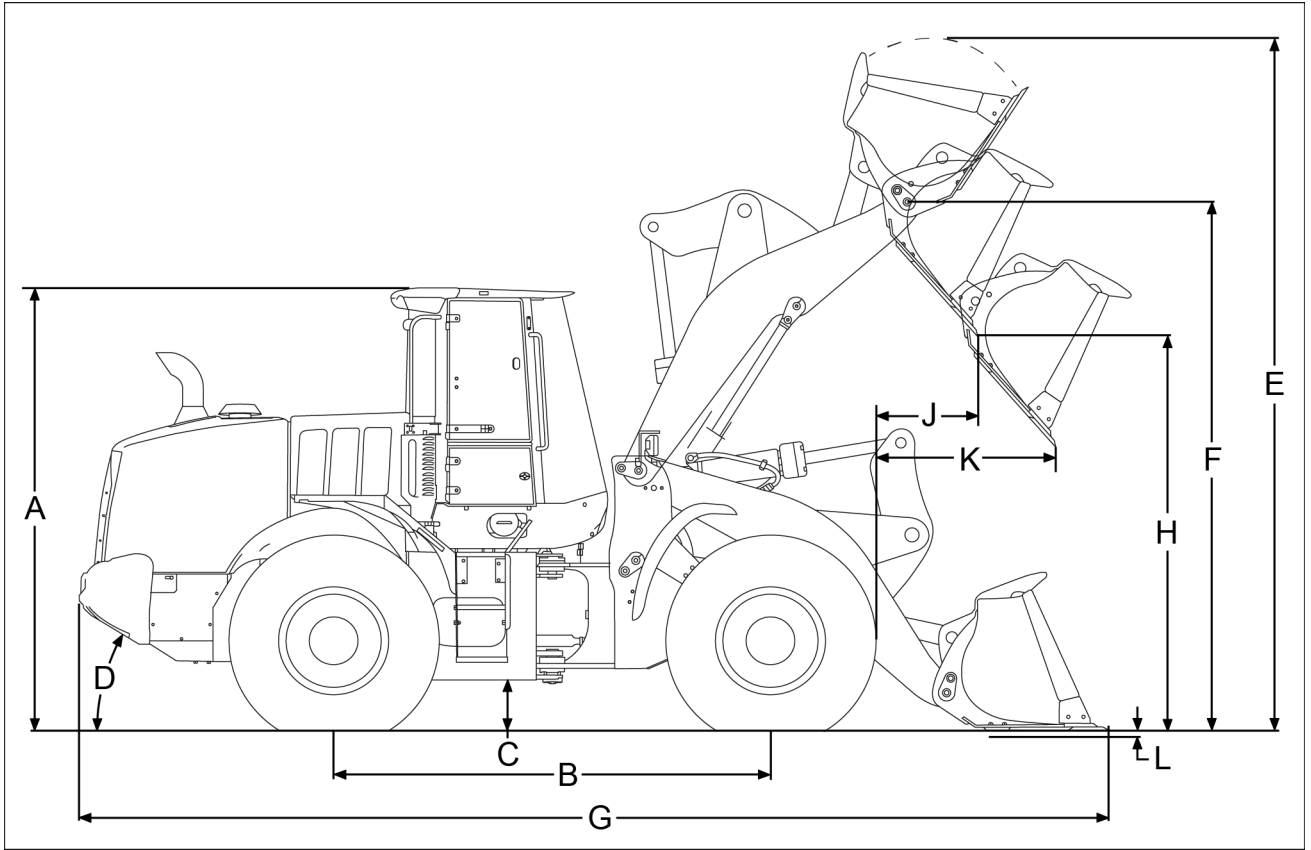

LEIL13WHL0323FB 2

821F Z-Bar Specifications - 3.2 m³ (4.25 yd³) Bucket (MD Pin On)

	Bolt-on Edge Bucket	w/Teeth Bucket
ISO Bucket Specifications		
Struck	2.71 m ³ (3.545 yd ³)	2.63 m ³ (3.44 yd ³)
Heaped	3.17 m ³ (4.146 yd ³)	3.05 m ³ (3.989 yd ³)
Bucket width (maximum outer)	3030 mm (119.3 in)	3046 mm (119.9 in)
Dimensional Outline Specifications		
A (top of cab height)	3450 mm (135.8 in)	3450 mm (135.8 in)
B (wheelbase)	3340 mm (131.5 in)	3340 mm (131.5 in)
C (ground clearance)	415.8 mm (16.4 in)	415.8 mm (16.4 in)
D (rear angle of departure)	32°	32°
Overall width w/o bucket	2885 mm (113.6 in)	2885 mm (113.6 in)
Centerline tread width	2230 mm (87.8 in)	2230 mm (87.8 in)
Turning radius (outside of tires)	6032 mm (237.5 in)	6032 mm (237.5 in)
Turning angle from center	40°	40°
Total turning angle	80°	80°
E (fully raised with spillguard)	5496 mm (216.4 in)	5474 mm (215.5 in)
F (hinge pin - fully raised)	4123 mm (162.3 in)	4123 mm (162.3 in)
G (overall - bucket level on ground)	7859 mm (309.4 in)	7838 mm (308.6 in)
H (dump - fully raised, 45° dump)	2983 mm (117.4 in)	2995 mm (117.9 in)
J (reach - fully raised, 45° dump)	1107 mm (43.6 in)	1085 mm (42.7 in)
K (reach - 2.13 m (7.0 ft), 45° dump)	1703 mm (67.0 in)	1686 mm (66.4 in)
L (dig depth)	75 mm (3.0 in)	80 mm (3.1 in)
ISO Load Specifications		
Operating load	6175 kg (13614 lb)	6216 kg (13704 lb)
Tipping load		
Machine straight	14275 kg (31471 lb)	14371 kg (31683 lb)
40° turn	12349 kg (27225 lb)	12432 kg (27408 lb)

8 - SPECIFICATIONS

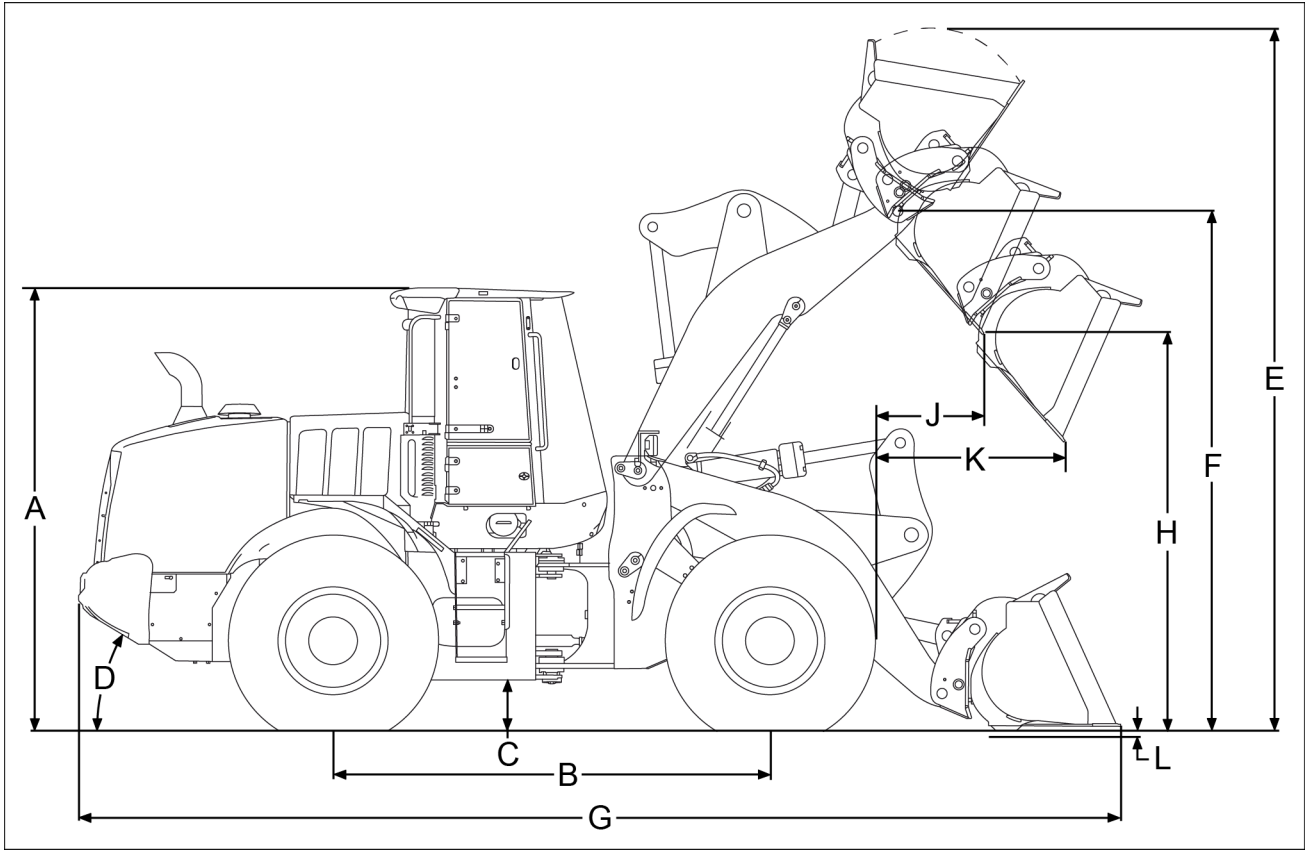

LEIL13WHL0322FB 12

821F XR Specifications - 2.7 m³ (3.50 yd³) Bucket GP on CNH Quick Coupler (ACS compatible)

	Bolt-on Edge Bucket	w/Teeth Bucket
ISO Bucket Specifications		
Struck	2.2 m ³ (2.88 yd ³)	2.10 m ³ (2.75 yd ³)
Heaped	2.60 m ³ (3.40 yd ³)	2.45 m ³ (3.20 yd ³)
Bucket width (maximum outer)	3030 mm (119.3 in)	3046 mm (119.9 in)
Dimensional Outline Specifications		
A (top of cab height)	3450 mm (135.8 in)	3450 mm (135.8 in)
B (wheelbase)	3340 mm (131.5 in)	3340 mm (131.5 in)
C (ground clearance)	415.8 mm (16.4 in)	415.8 mm (16.4 in)
D (rear angle of departure)	32°	32°
Overall width w/o bucket	2885 mm (113.6 in)	2885 mm (113.6 in)
Centerline tread width	2230 mm (87.8 in)	2230 mm (87.8 in)
Turning radius (outside of tires)	6032 mm (237.5 in)	6032 mm (237.5 in)
Turning angle from center	40°	40°
Total turning angle	80°	80°
E (fully raised with spillguard)	5882 mm (231.6 in)	5882 mm (231.6 in)
F (hinge pin - fully raised)	4562 mm (179.6 in)	4562 mm (179.6 in)
G (overall - bucket level on ground)	8382 mm (330.0 in)	8532 mm (335.9 in)
H (dump - fully raised, 45° dump)	3399 mm (133.8 in)	3301 mm (129.9 in)
J (reach - fully raised, 45° dump)	1243 mm (48.9 in)	1354 mm (53.3 in)
K (reach - 2.13 m (7.0 ft), 45° dump)	2152 mm (84.7 in)	2221 mm (87.4 in)
L (dig depth)	147 mm (5.8 in)	151 mm (6.0 in)
ISO Load Specifications		
Operating load	4385 kg (9667 lb)	4460 kg (9633 lb)
Tipping load		
Machine straight	10323 kg (22758 lb)	10485 kg (23116 lb)
40° turn	8770 kg (19335 lb)	8921 kg (19667 lb)

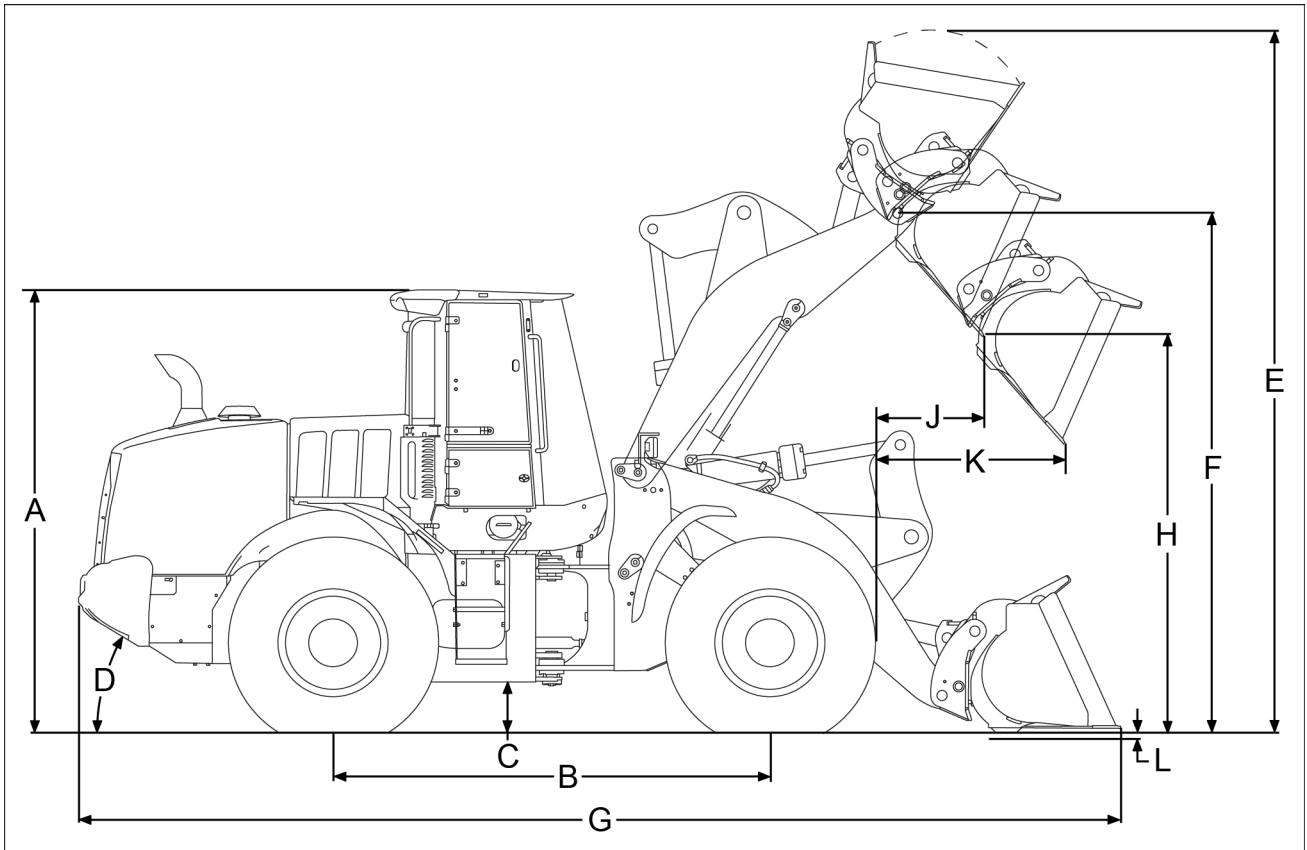

LEIL13WHL0322FB 22

921F XR Specifications - 3 m³ (4 yd³) Bucket GP on CNH Quick Coupler (JRB compatible)

	Bolt-on Edge Bucket	w/Teeth Bucket
ISO Bucket Specifications		
Struck	2.61 m ³ (3.41 yd ³)	2.49 m ³ (3.26 yd ³)
Heaped	3.06 m ³ (4.00 yd ³)	2.93 m ³ (3.83 yd ³)
Bucket width (maximum outer)	3030 mm (119.3 in)	3051 mm (120.1 in)
Dimensional Outline Specifications		
A (top of cab height)	3450 mm (135.8 in)	3450 mm (135.8 in)
B (wheelbase)	3340 mm (131.5 in)	3340 mm (131.5 in)
C (ground clearance)	415.8 mm (16.4 in)	415.8 mm (16.4 in)
D (rear angle of departure)	30°	30°
Overall width w/o bucket	2885 mm (113.6 in)	2885 mm (113.6 in)
Centerline tread width	2230 mm (87.8 in)	2230 mm (87.8 in)
Turning radius (outside of tires)	6032 mm (237.5 in)	6032 mm (237.5 in)
Turning angle from center	40°	40°
Total turning angle	80°	80°
E (fully raised with spillguard)	6077 mm (239.2 in)	6077 mm (239.2 in)
F (hinge pin - fully raised)	4558 mm (179.5 in)	4558 mm (179.5 in)
G (overall - bucket level on ground)	8061 mm (338.6 in)	8755 mm (344.7 in)
H (dump - fully raised, 45° dump)	3257 mm (128.2 in)	3157 mm (124.3 in)
J (reach - fully raised, 45° dump)	1413 mm (55.6 in)	1527 mm (60.1 in)
K (reach - 2.13 m (7.0 ft), 45° dump)	2261 mm (89.0 in)	2326 mm (91.6 in)
L (dig depth)	147 mm (5.8 in)	151 mm (6.0 in)
ISO Load Specifications		
Operating load	5094 kg (11230 lb)	5178 kg (11415 lb)
Tipping load		
Machine straight	12039 kg (26541 lb)	12220 kg (26941 lb)
40° turn	10188 kg (22460 lb)	10355 kg (22830 lb)

CLICK HERE TO **DOWNLOAD** THE COMPLETE MANUAL

- Thank you very much for reading the preview of the manual.
- You can download the complete manual from: www.heydownloads.com by clicking the link below



- Please note: If there is no response to CLICKING the link, please download this PDF first and then click on it.

CLICK HERE TO **DOWNLOAD** THE COMPLETE MANUAL