

ORIGINAL INSTRUCTIONS

580N EP
Tier 4B (final)
Tractor Loader Backhoe
PIN NJC757537 and above

OPERATOR'S MANUAL

Part number 51536635

2nd edition English
September 2018

Replaces part number 48188110



CLICK HERE TO **DOWNLOAD** THE COMPLETE MANUAL

- Thank you very much for reading the preview of the manual.
- You can download the complete manual from: www.heydownloads.com by clicking the link below



- Please note: If there is no response to CLICKING the link, please download this PDF first and then click on it.

CLICK HERE TO **DOWNLOAD** THE COMPLETE MANUAL

Electro-Magnetic Compatibility (EMC)

Interference may arise as a result of add-on equipment which may not necessarily meet the required standards. As such interference can result in serious malfunction of the unit and/or create unsafe situations, you must observe the following:

- The maximum power of emission equipment (radio, telephones, etc.) must not exceed the limits imposed by the national authorities of the country where you use the machine.
- The add-on equipment must not interfere with the functioning of the onboard electronics.

Failure to comply with these rules will render the CASE CONSTRUCTION warranty null and void.

California Emission Control Warranty Statement

Your warranty rights and obligations

California Air Resources Board and FPT Industrial S.p.A. are pleased to explain the emission control system warranty on 2015 through 2017 off-road diesel engine. In California, new heavy-duty off-road engines must be designed, built and equipped to meet the State's stringent anti-smog standards. FPT Industrial S.p.A. must warrant the emission control system on your engine for the periods of time listed below provided there has been no abuse, neglect or improper maintenance of your engine.

Your emission control system may include parts such as the fuel injection system and the air induction system. Also included may be hoses, belts, connectors and other emission-related assemblies.

Where a warrantable condition exists, FPT Industrial S.p.A. will repair your heavy-duty off-road engine at no cost to you including diagnosis, parts and labor.

MANUFACTURER'S WARRANTY COVERAGE:

The 2015-2017 heavy-duty off-road engines are warranted for 5 years or 3000 hours, whichever comes first. If any emission-related part on your engine is defective, the part will be repaired or replaced by FPT Industrial S.p.A.

OWNER'S WARRANTY RESPONSIBILITIES:

- As the off-road engine owner, you are responsible for the performance of the required maintenance listed in your owner's manual. FPT Industrial S.p.A. recommends that you retain all receipts covering maintenance on your off-road engine, but CASE CONSTRUCTION cannot deny warranty solely for the lack of receipts or for your failure to ensure the performance of all scheduled maintenance.
- As the off-road engine owner, you should however be aware that FPT Industrial S.p.A. may deny you warranty coverage if your off-road engine or a part has failed due to abuse, neglect, improper maintenance or unapproved modifications.
- Your engine is designed to operate on Ultra Low Sulfur Diesel fuel only. Use of any other fuel may result in your engine no longer operating in compliance with California's emissions requirements.
- You are responsible for initiating the warranty process. The ARB suggests that you present your off-road engine to a CASE CONSTRUCTION dealer as soon as a problem exists. The warranty repairs should be completed by the dealer as expeditiously as possible.

If you have any questions regarding your warranty rights and responsibilities, you should contact NAFTA Technical Service Group at 1-630-481-2905 or email: fpt-na-warranty@fptindustrial.com.

CALIFORNIA EMISSION CONTROL WARRANTY PARTS LIST

Fuel injection system:

- Fuel injection pump
- Fuel injectors
- Fuel injection lines

Air induction system:

- Intake manifold
- Turbocharger system (includes exhaust manifold)
- Charge air cooler

Positive Crankcase Ventilation (PCV) system (if applicable)

- PCV valve
- Oil fill cap

Exhaust after treatment Devices (if applicable)

- Diesel Oxidation Catalyst (DOC)
- Diesel Particulate Filter (DPF)
- Selective Catalytic Reduction (SCR)
- Diesel Exhaust Fluid (DEF) tank and dispensing systems

Exhaust Gas Recirculation Systems (EGR)

- EGR valve assembly
- EGR cooler

Cold Start Enrichment Systems

Electronic Control Units, Sensors, Solenoids, and Wiring harnesses used in above systems

Miscellaneous items used in above systems, such as hoses, belts, connectors, tubing, gaskets, mounting hardware, and Emission Control Information Labels.

Electrical storm safety

Do not operate machine during an electrical storm.

If you are on the ground during an electrical storm, stay away from machinery and equipment. Seek shelter in a permanent, protected structure.

If an electrical storm should strike during operation, remain in the cab. Do not leave the cab or operator's platform. Do not make contact with the ground or objects outside the machine.

Mounting and dismounting

Mount and dismount the machine only at designated locations that have handholds, steps, and/or ladders.

Do not jump off of the machine.

Make sure that steps, ladders, and platforms remain clean and clear of debris and foreign substances. Injury may result from slippery surfaces.

Face the machine when you mount and dismount the machine.

Maintain a three-point contact with steps, ladders, and handholds.

Never mount or dismount from a moving machine.

Do not use the steering wheel or other controls or accessories as handholds when you enter or exit the cab or operator's platform.

Working at heights

When the normal use and maintenance of the machine requires you to work at heights:

- Correctly use installed steps, ladders, and railings.
- Never use ladders, steps, or railings while the machine is moving.

- Do not stand on surfaces that are not designated as steps or platforms.

Do not use the machine as a lift, ladder, or platform for working at heights.

Lifting and overhead loads

Never use loader buckets, forks, etc. or other lifting, handling, or digging equipment to lift persons.

Do not use raised equipment as a work platform.

Know the full area of movement of the machine and equipment and do not enter or permit anyone to enter the area of movement while the machine is in operation.

Never enter or permit anyone to enter the area underneath raised equipment. Equipment and/or loads can fall unexpectedly and crush persons underneath it.

Do not leave equipment in raised position while parked or during service, unless securely supported. Hydraulic cylinders must be mechanically locked or supported if they are left in a raised position for service or access.

Loader buckets, forks, etc. or other lifting, handling, or digging equipment and its load will change the center of gravity of the machine. This can cause the machine to tip on slopes or uneven ground.

Load items can fall off the loader bucket or lifting equipment and crush the operator. Care must be taken when lifting a load. Use proper lifting equipment.

Do not lift load higher than necessary. Lower loads to transport. Remember to leave appropriate clearance to the ground and other obstacles.

Equipment and associated loads can block visibility and cause an accident. Do not operate with insufficient visibility.

Keep the load or tool as low as possible while moving the machine around the work site.

Release all hydraulic pressure before servicing the machine.

You must know which circuits have accumulators and how to release pressure properly.

Always use the lift arm support strut when servicing the machine with lift arms up.

Stop

Wave one hand back and forth

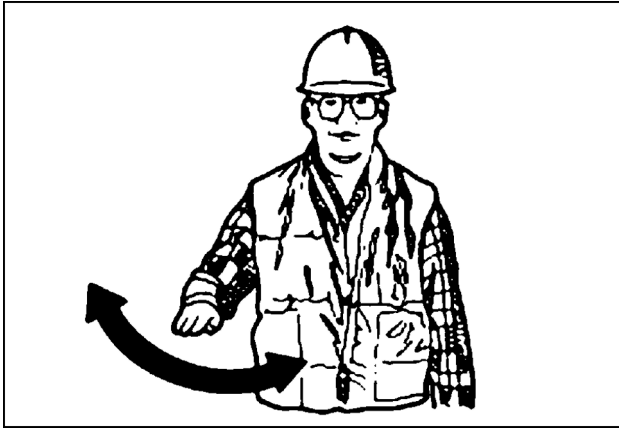

RCIL09TLB019BAF 7

Lower load or bucket



RCIL09TLB021BAF 8

Emergency stop

Wave both hands back and forth

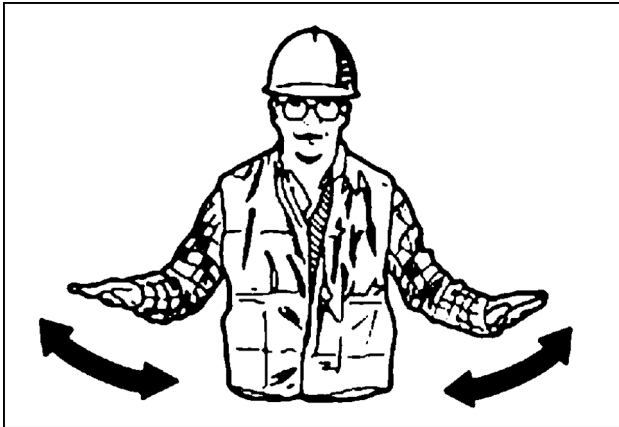

RCIL09TLB024BAF 9

Raise load or bucket slowly

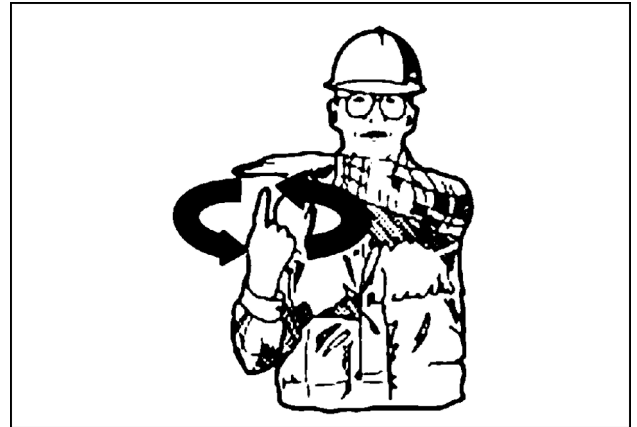

RCIL09TLB008BAF 10

Raise load or bucket

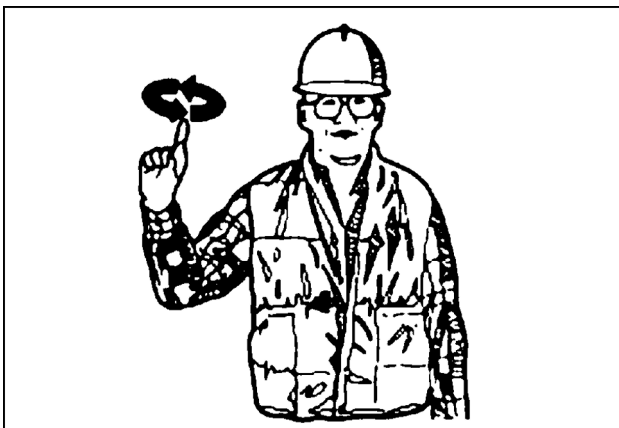

RCIL09TLB020BAF 11

Lower load or bucket slowly

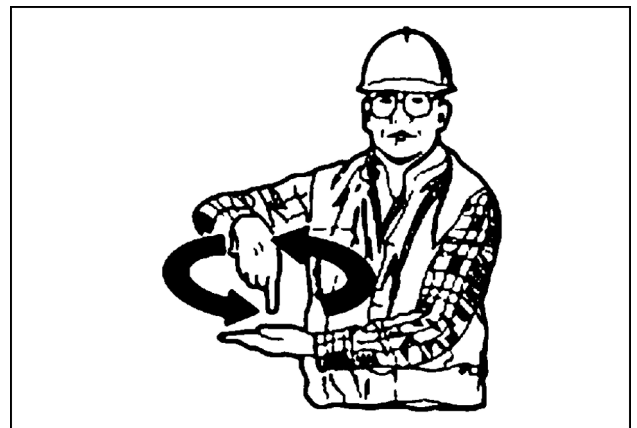

RCIL09TLB022BAF 12

(5) Do not start in gear. Start only from Operator's seat

DANGER

Starting in gear can cause death. Start engine only from operator seat with the transmission in NEUTRAL. Failure to comply will result in death or serious injury.

Quantity: 1
English 321-7040
Spanish 398674A1
French Canadian 398676A1



321-7040 15

Location:
On the right-hand side of the machine frame.

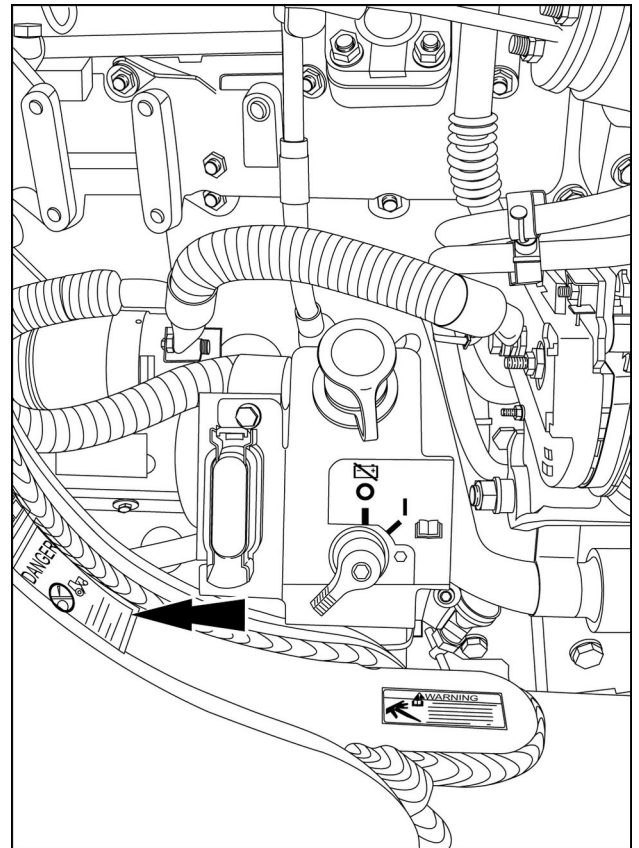

RAIL18TLB0460BA 16

(19) Not a step/exit. Machines with ROPS canopy only

WARNING

No step. Not an exit. Failure to comply could result in death or serious injury.

**Quantity: 2
English 86992975
Spanish 86992980
French Canadian 86992978**



86992975C 41

Location:
On each side of the rear frame.

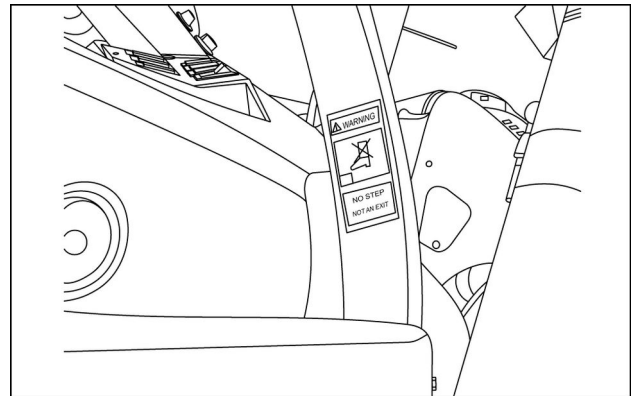

RCPH10TLB127AAF 42

3 - CONTROLS AND INSTRUMENTS

ACCESS TO OPERATOR'S PLATFORM

Machine access

⚠ WARNING

Fall hazard!

Jumping on or off the machine could cause an injury. Always face the machine, use the handrails and steps, and get on or off slowly. Maintain a three-point contact to avoid falling: both hands on the handrails and one foot on the step, or one hand on the handrail and both feet on the steps.

Failure to comply could result in death or serious injury.

W0141A

⚠ WARNING

Fall hazard!

Clean the steps and access handles to remove all traces of grease, oil, mud, and ice (in winter).

Failure to comply could result in death or serious injury.

W0139A

⚠ WARNING

Unexpected movement!

Always engage the parking brake and switch off the engine before exiting the machine.

Failure to comply could result in death or serious injury.

W0209A

⚠ WARNING

Fall hazard!

When entering or exiting the cab, never use the control levers as handholds. Always mount and dismount the machine in a safe way. Maintain a three-point contact with steps, ladders, and/or handholds.

Failure to comply could result in death or serious injury.

W1340B

⚠ WARNING

Fall hazard!

Do not stand or step on the areas marked with a "No step" decal. These areas are not designed as a step, and do not provide non-slip steps and/or handrails.

Failure to comply could result in death or serious injury.

W1499A

Rotating beacon, if equipped:



Press the emblem end of the rocker switch to activate the beacon light. Press the opposite end to turn off the beacon light.

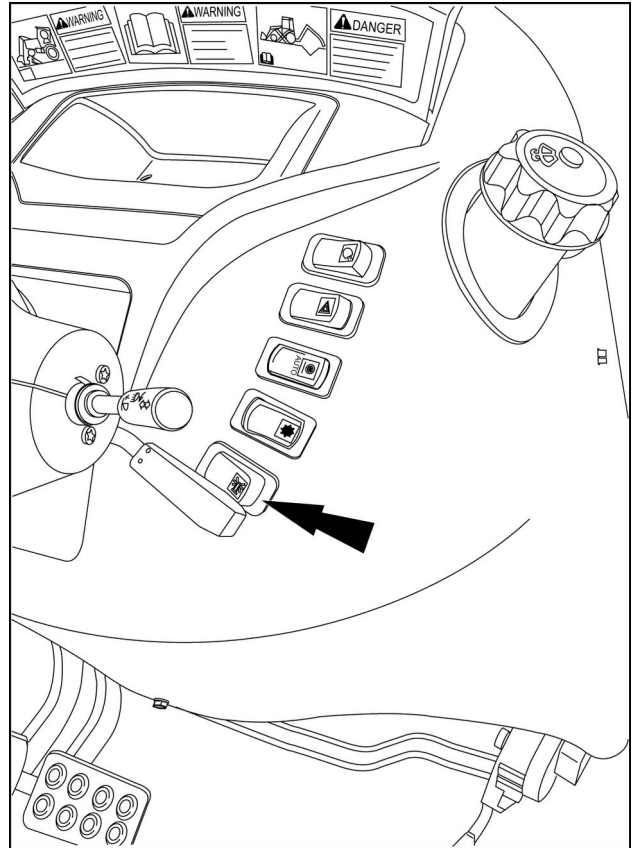

RAIL18TLB0475BA 4

If applicable, windshield wiper fluid container. Fill with windshield washer fluid as needed.

NOTICE: Do not fill with water during cold weather seasons.

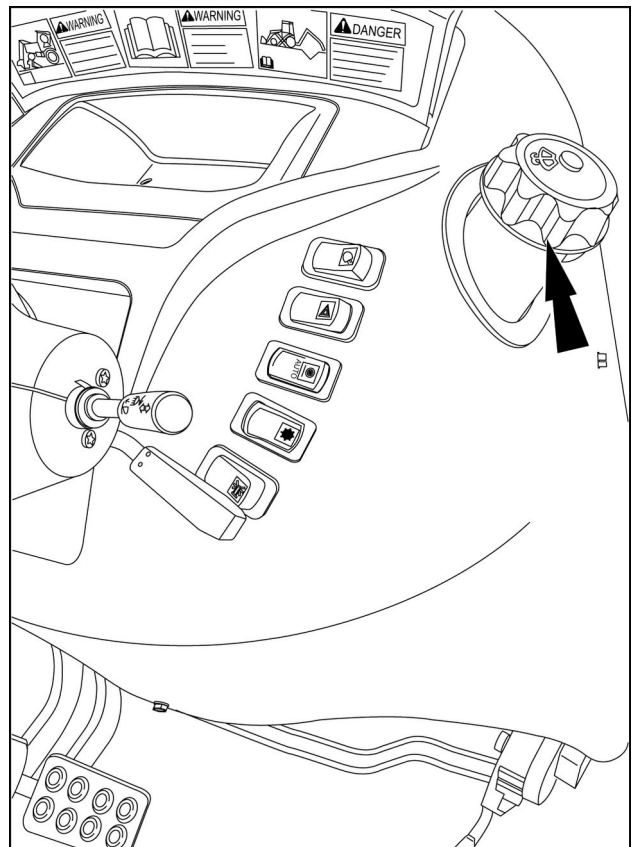

RAIL18TLB0475BA 5

3 - CONTROLS AND INSTRUMENTS

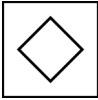

Press the ENTER button to select menus on the display.



Press the ESCAPE button to select and or exit menus on the display.

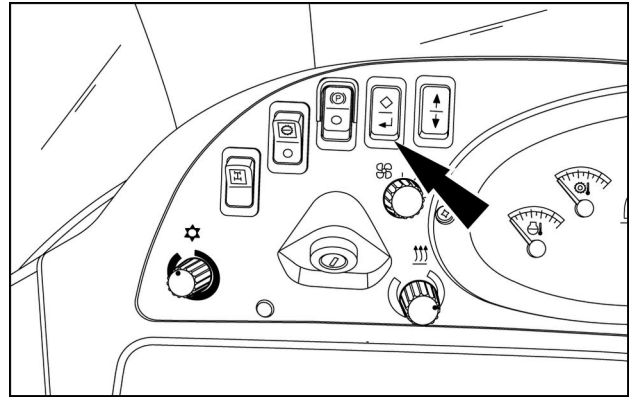

RAIL18TLB0467AA 4



Press the UP arrow button to scroll through the available menu screens.

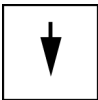

Press the DOWN arrow button to scroll through the available menu screens.

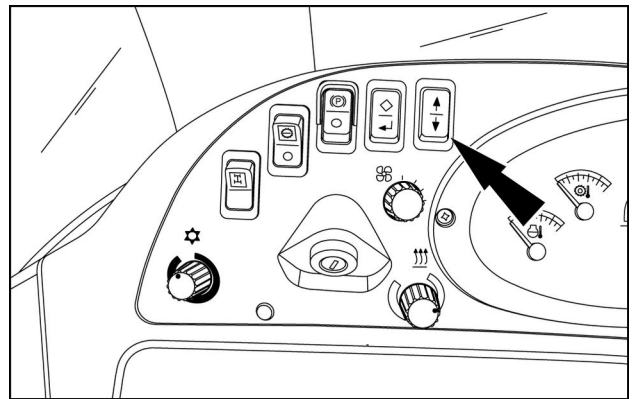

RAIL18TLB0467AA 5

4. Move the rubber stoppers (2) from the top of the fixed window upward to support the middle internal locking sections (1).

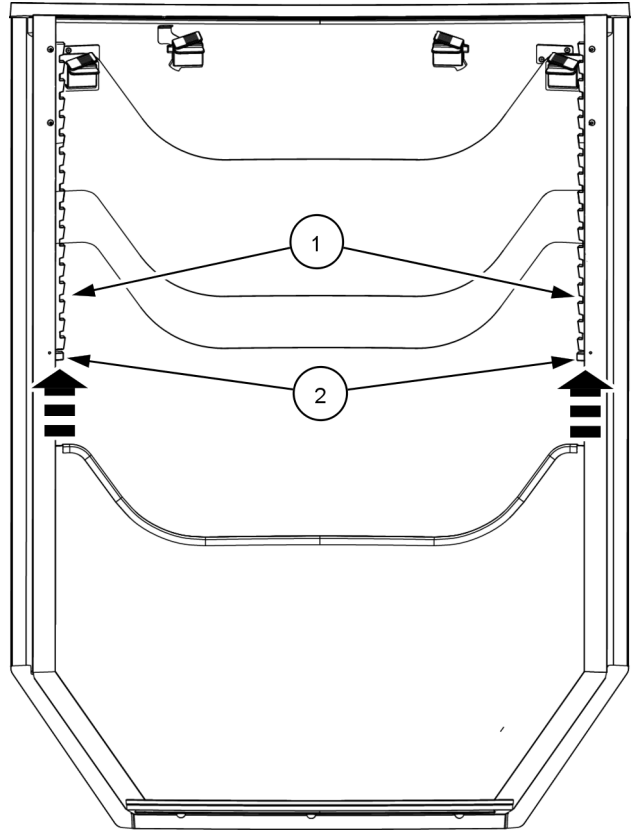

RAIL17TLB0497BA 15

NOTICE: The upper part of the rear window frame is wider than the width of the bottom window. If you remove all of the middle sections of the internal locking rail, the higher you raise the bottom window the more likely you will remove the bottom window from the frame. Use caution not to drop the bottom window.

5. Raise the bottom window (1); place a support block between the bottom of the window (2) and the frame (3).

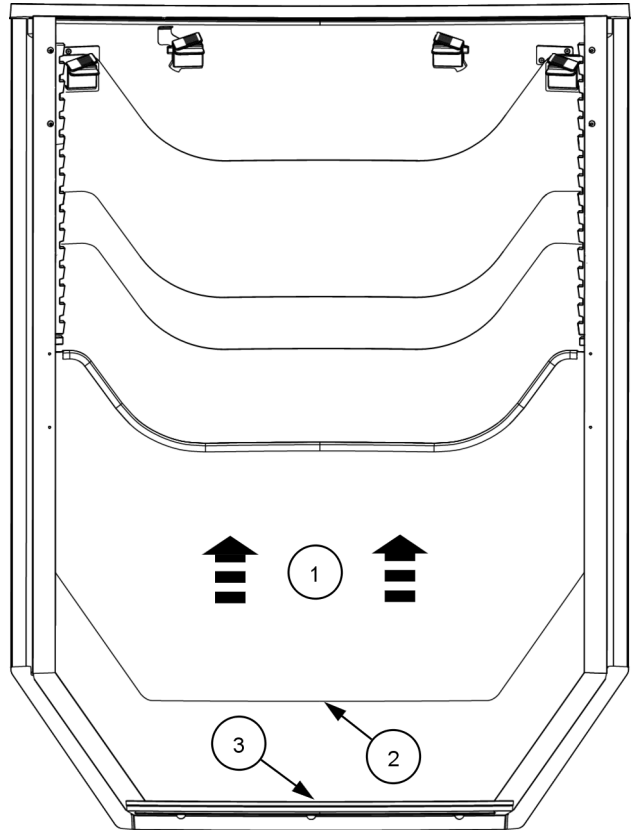

RAIL17TLB0496BA 16

Backhoe controls - Pilot

⚠ WARNING

Unexpected machine movement!

Pilot controls have two different backhoe controls patterns; before operating the machine, check which control function is active.

Failure to comply could result in death or serious injury.

W0185A

Backhoe control pattern switch

Select between Backhoe or Excavator control patterns. To change the switch position, push the orange locking tab towards the center of the switch to release the lock. Once the selection is made move the tab into the locked position.

NOTE: To prevent accidental switching of the patterns, use two hands to change the switch position.

For information on the functions controlled by the two patterns, refer to the decal on the tower and/or the examples that follow.

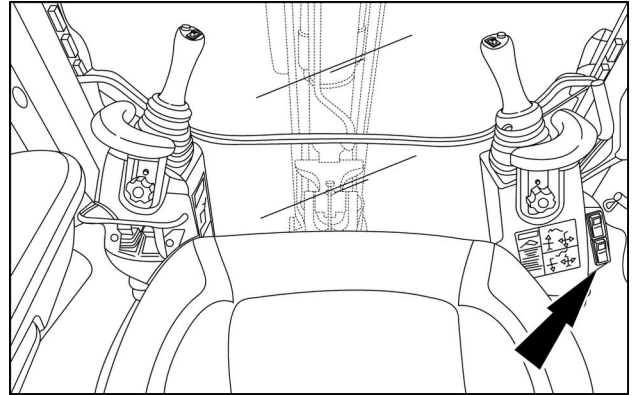

RAIL18TLB0471AA 1

Backhoe control pattern 1 (factory setting)

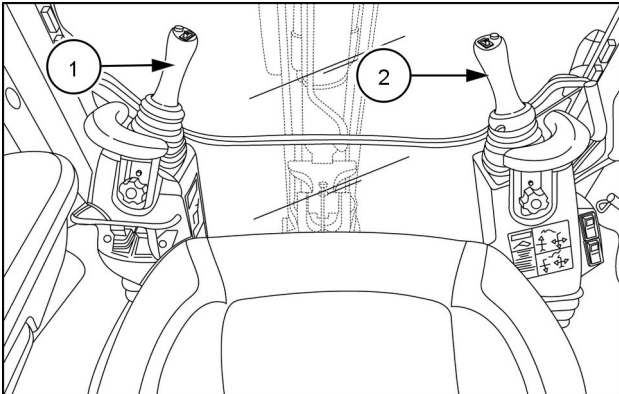

RAIL18TLB0471AA 2

- (1) Boom and swing (2) Dipper and bucket

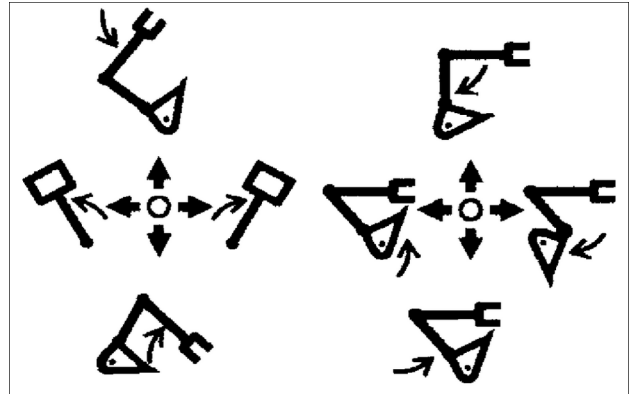

RCPH10TLB006BAF 3

Excavator control pattern 2

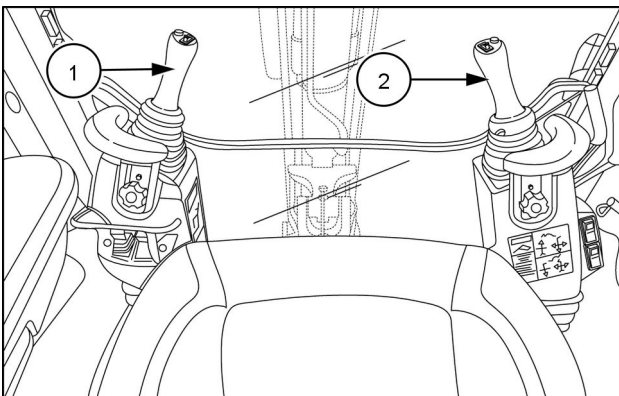

RAIL18TLB0471AA 4

- (1) Dipper and swing (2) Boom and bucket

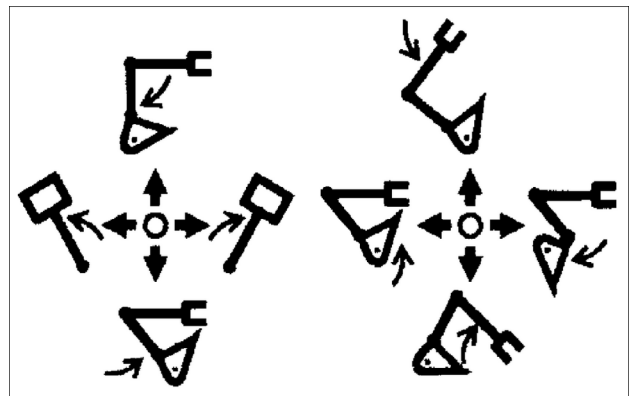

RCPH10TLB157AAF 5

Voltmeter

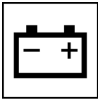

Indicates the condition of the electrical system. The electrical system voltage is normal when the gauge needle is in the green area of the gauge (**11 – 15.3 V**) when the key switch is in the ON position. When the gauge needle is in the lower red area, the charge of the battery is too low or the alternator is not charging enough.

NOTICE: When the gauge continues to read in the red area, this will result in damage to the battery. Identify and rectify the cause/contact your dealer

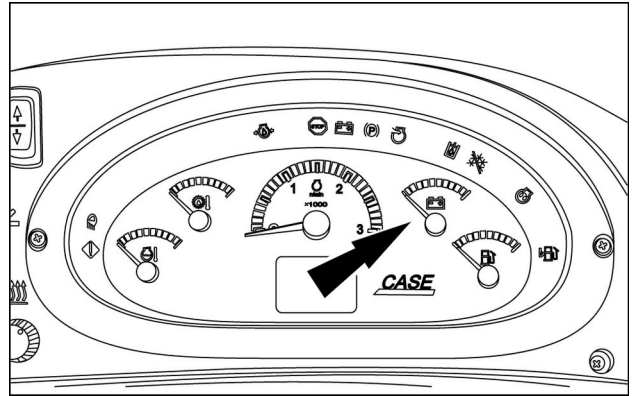

RCPH10TLB138AAF 15

Fuel level



Indicates the level of fuel in the machine. When the fuel level is low, the low fuel level warning light also illuminates.

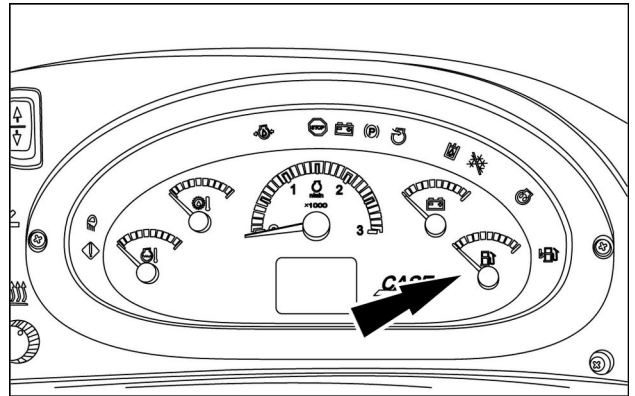

RCPH10TLB138AAF 16

Machine start up in cold weather

Machines at temperatures below **-2 °C (29 °F)**:

1. If equipped, plug the engine block heater into an appropriate electrical outlet a few hours before starting the machine.
2. Turn the key switch to the ON position and check the instrument cluster.
3. If the machine is equipped with a pre-heat system, wait for the engine pre-heat lamp to stop illuminating.
4. Turn the key switch to the START position until the engine starts, then release the key.

NOTE: *If the engine fails to start after a maximum of 30 s of cranking, repeat the starting procedure. Do not operate the starting motor for more than 60 s.*

Machines at temperatures of **-15 °C (5 °F)** or lower:

- Do not wait longer than **30 s** after the engine pre-heat lamp has stopped illuminating before cranking the engine. If the delay is longer, the start up cycle is aborted and the process must be restarted.
- The Engine Control Unit (ECU) limits the maximum speed of the engine to **1200 RPM** until the engine is properly warmed.

Warm up the hydraulic system

When the temperature is below **4 °C (40 °F)** you must warm up the hydraulic system:

1. Run the engine at **1000 RPM** until the coolant temperature is warm.
2. Leave the boom in the transport position with the swing lock pin installed.
3. If the machine is equipped with pilot controls, ensure the backhoe and stabilizer control switch is enabled for all backhoe controls.
4. Raise the engine throttle between **1600 – 1800 RPM**.
5. Place and hold the boom control in the down position.
6. While holding the boom control to the end of the levers, stroke cycle the backhoe bucket in and out.

NOTE: *Watch the filter restriction indicator lamp. If the oil is too cold the lamp will illuminate while the operator cycles the functions.*

7. Cycle the functions for approximately **30 s**.
8. Release the controls and leave the machine throttle set for approximately **15 s**.
9. Repeat steps 6 – 8 until the filter restriction indicator lamp remains off while cycling functions.

NOTE: *Immediately after the warm up procedure, the machine may operate a bit slower than normal, but will quickly warm to normal operating speeds.*

Ride Control™ - Two-Wheel Drive (2WD) only

⚠ WARNING

Unexpected machine movement!

Stand clear of the loader arms. With ride control enabled and the key switch in the ON or ACC position, the loader arms can drop slightly due to the hydraulic accumulator.

Failure to comply could result in death or serious injury.

W0177A

⚠ WARNING

Unexpected movement!

Stand clear of the machine. Activating ride control when the loader arm is applying down force, for example supporting or lifting the front end of the machine off the ground, may cause the machine or load to lower unexpectedly.

Failure to comply could result in death or serious injury.

W1163A

Ride Control™ is an optional feature for machines with Two-Wheel Drive (2WD). When **Ride Control™** is activated, the loader down pressure is limited to the weight of the loader and the attachment (bucket). The weight of the loader attachment is hydraulically cushioned during transport.

NOTE: Do not use **Ride Control™** when the bucket is used in fine grading operations or when precision placement of a load suspended from the bucket or other attachment is required.

Before activating **Ride Control™** perform the following actions:

- Place the operator seat in the forward driving position.
- Place the hand throttle control at low idle.
- Only use the foot throttle.
- Make sure that the loader arm is not applying down force.

Activate **Ride Control™**:

1. Lower the loader bucket to or near the ground line.
2. Press the emblem end of the rocker switch to enable **Ride Control™**. The emblem illuminates.
3. Disable **Ride Control™**, press the blank side of the rocker switch. The emblem no longer illuminates.

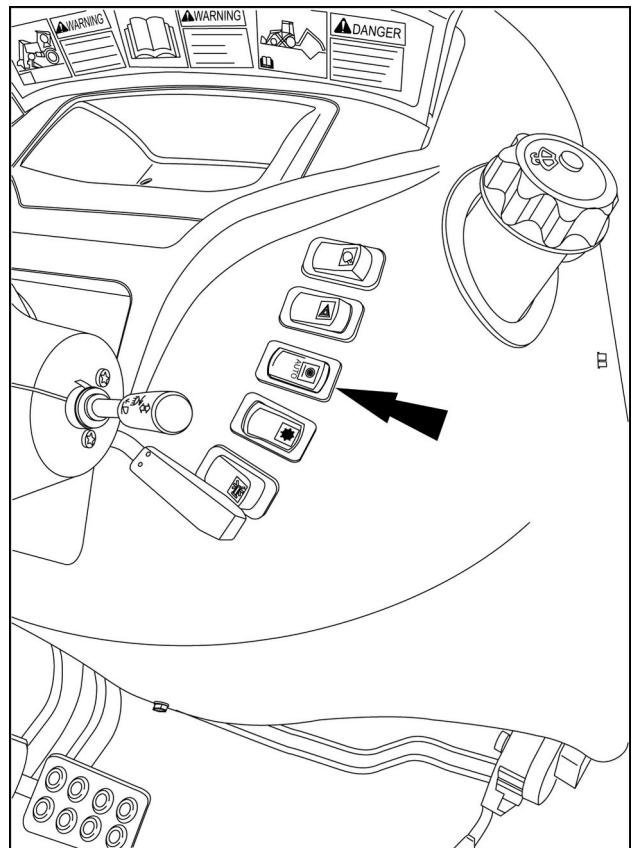

RAIL18TLB0475BA 1

6 - WORKING OPERATIONS

GENERAL INFORMATION

Forward-Neutral-Reverse (F-N-R) shift sensitivity

NOTE: Machines with the optional PowerDrive transmissions only.

Change F-N-R shift sensitivity:

1. Press Enter (**4**) to access the menu screens.
2. Press the up arrow (**2**) or the down arrow (**3**) to navigate through the menu screens.

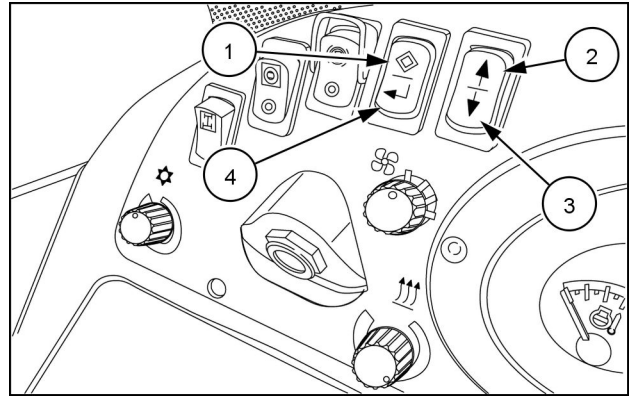

RAIL18TLB0473AA 1

3. When the F-N-R shift sensitivity screen displays, press Enter. The setting bar flashes.
4. Press the up arrow or the down arrow to adjust the setting, where 1 is least aggressive and 3 is most aggressive.
5. Press Enter to save the selection.

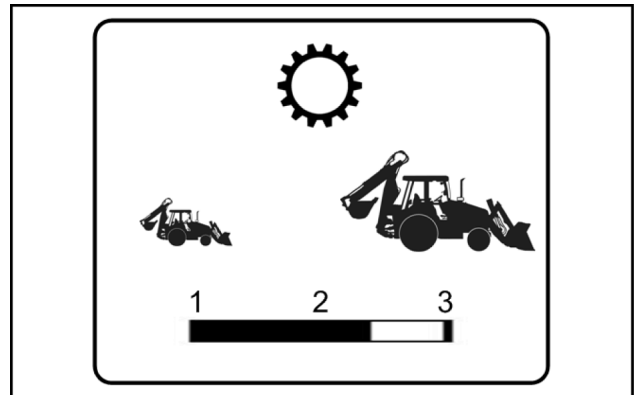

RCIL10TLB035AAF 2

6. Use the arrows to navigate to a different menu screen or press Escape (**1**) until you return the main screen (engine hour meter).

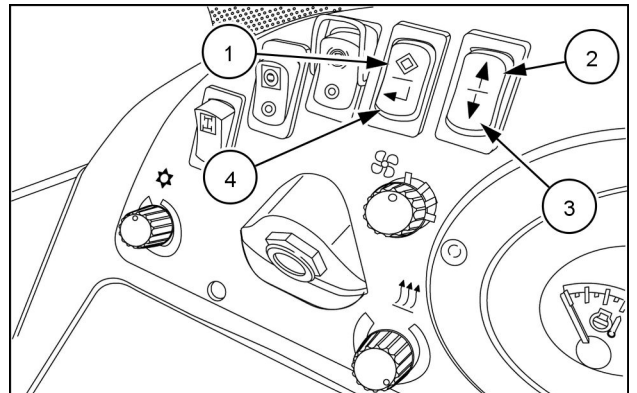

RAIL18TLB0473AA 3

LOADER OPERATIONS

Personal safety

This manual contains only basic information that you need to operate the machine, it does not include all possible conditions for loader operation.

If you are a new operator, always operate in a clear area at a decreased engine speed.

Be a careful operator. You can prevent accidents. Do not allow yourself to become complacent.

Fasten the seat belt before you start the engine.

Confirm that you can reach all controls and move through their entire range of motion with the seat belt fastened.

8. Start up the engine.
9. Raise the loader bucket to full height and dump the bucket.
10. Put the loader control lever in the return to dig position. The loader bucket will lower to the ground.
11. Shut down the engine.
12. Check the position of the loader bucket. If the bucket is not in the correct position:
 - Move the return to dig switch rearward if the bucket did not roll back far enough.
 - Move the return to dig switch forward if the bucket rolled back too far.
13. Repeat the procedure until the bucket returns to the correct position.

CLICK HERE TO **DOWNLOAD** THE COMPLETE MANUAL

- Thank you very much for reading the preview of the manual.
- You can download the complete manual from: www.heydownloads.com by clicking the link below



- Please note: If there is no response to CLICKING the link, please download this PDF first and then click on it.

CLICK HERE TO **DOWNLOAD** THE COMPLETE MANUAL

2. Rotate the transport lock struts (2) to the hole on the dipper (E).

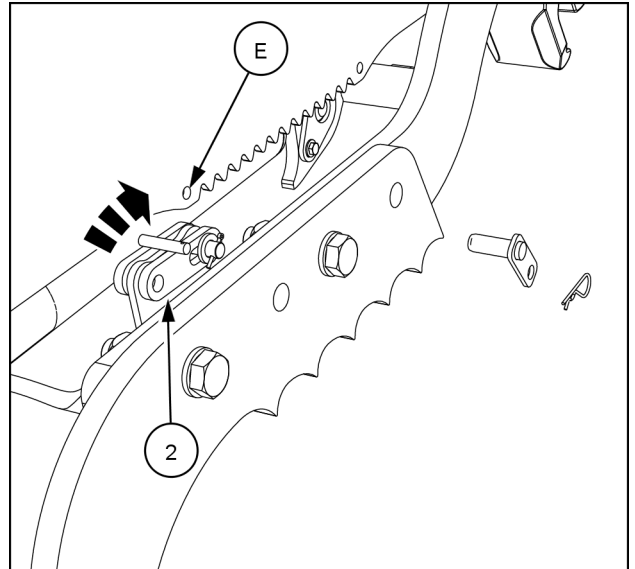

RAIL18TLB0172BA 6

3. Insert the transport lock pin (2) through the transport lock strut (3) and the dipper.
4. Secure the lock position with the cotter hairpin (1).
5. Make sure that the transport lock pin is fully inserted through both transport lock strut openings.

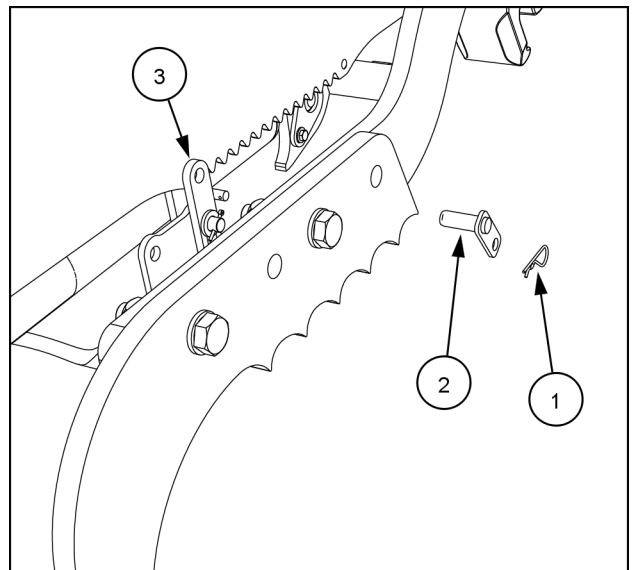

RAIL18TLB0174BA 7

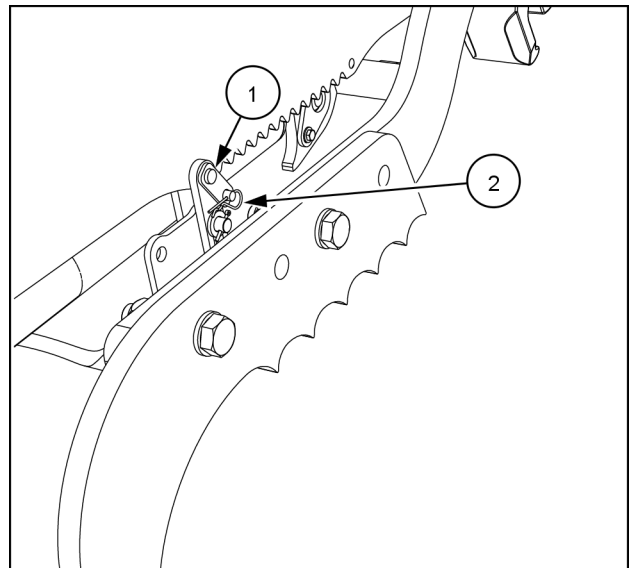

RAIL18TLB0173BA 8

3. Insert the transport lock pin (2) through the transport lock strut (3) and storage bracket (W).

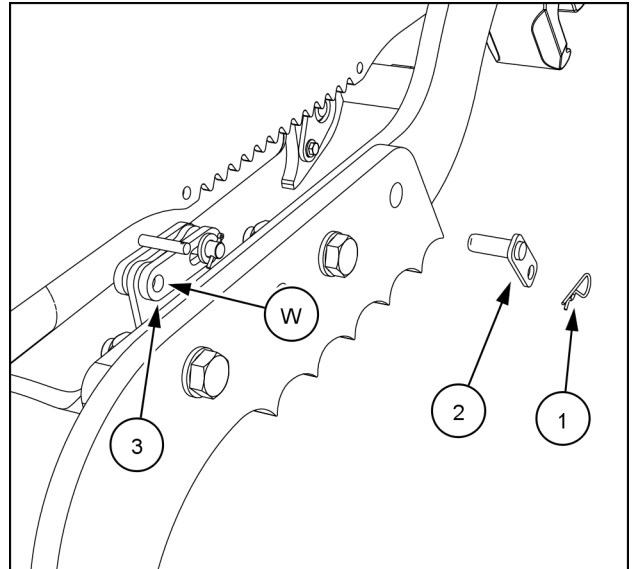

RAIL18TLB0172BA 3

4. Secure the transport lock strut storage position with the cotter pin (1)

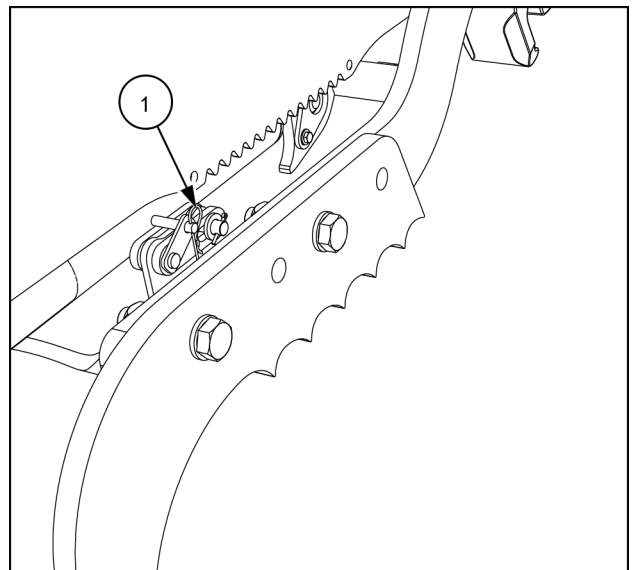

RAIL18TLB0171BA 4

Hydraulic quick coupler (optional)

NOTE: The operator seat must be in the backhoe operating position and the park brake engaged.

Remove a bucket:

1. Make sure the bucket has a hydraulic quick coupler installed.
2. Rotate the bucket out and lower to the ground.

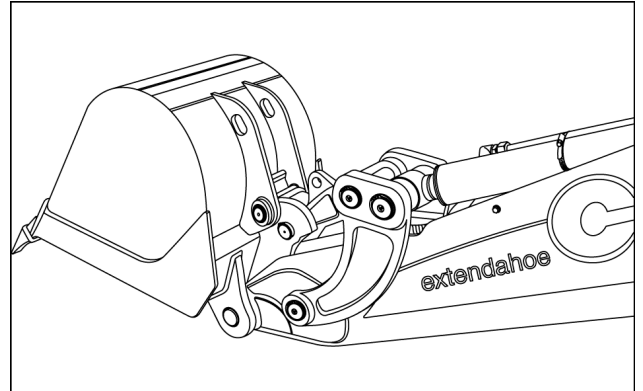

RCPH10TLB402AAF 23

3. Press and hold the top of the quick coupler switch  to disengage/retract the quick coupler.

Example: Quick coupler retracted

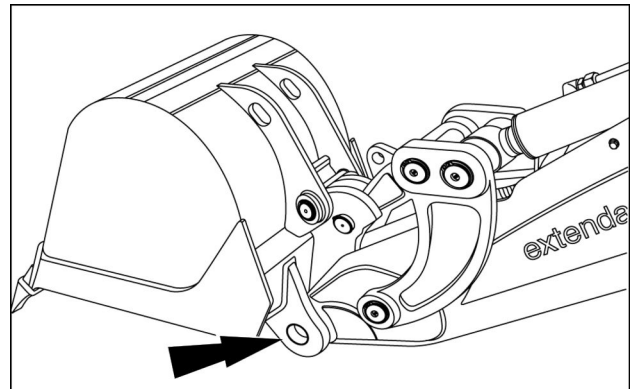

RCPH10TLB403AAF 24

4. Continue pressing the top of the quick coupler switch  and extend the bucket cylinder to rotate the quick coupler out of the bucket.
5. Back the coupler away from the bucket.

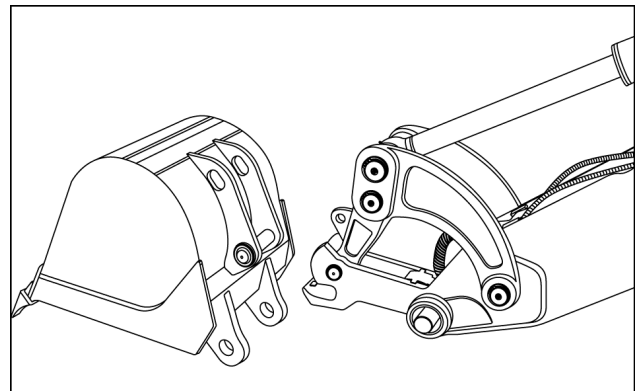

RCPH10TLB404AAF 25

Hood latch

Open the hood:

1. Shut down the engine.
2. Turn the handle counter-clockwise to release the hood latch.

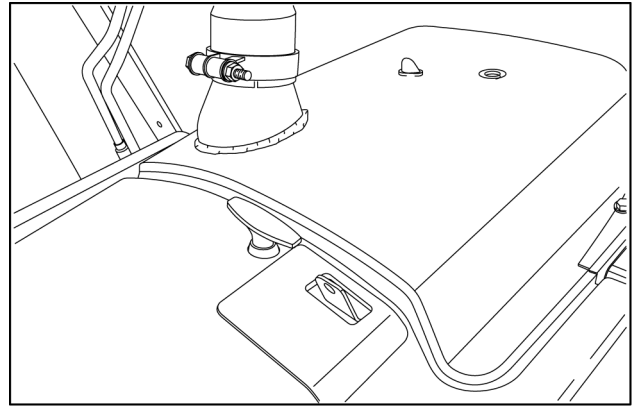

RCPH11TLB017AAD 1

3. Lift the hood and rotate forward.

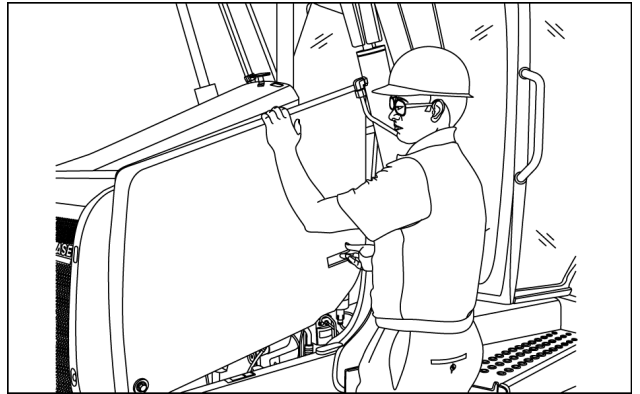

RCPH10TLB356AAF 2

NOTICE: To avoid damage to the hood parts, always close the hood before moving the loader.

Close the hood:

1. Lower the hood.
2. Turn the handle clockwise to lock the hood latch.

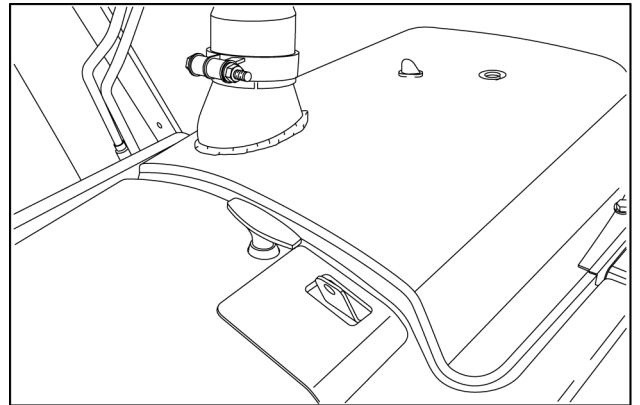

RCPH11TLB017AAD 3

Consumables

For the very best protection of your investment, use the recommended lubrication and service products. Contact your dealer for these products and any questions you might have about the service and lubrication requirements of the machine.

Always remember the environment before you service the machine and before you dispose of the old fluids and lubricants.

You must follow local, state, and regional regulations when disposing of fluids, filters, fuels, and lubricants.

- Do not put oil or fluids into the ground or into containers that can leak.
- Check with your local environmental or recycling center or your dealer for correct disposal information.

Systemgard™ lubrication analysis

Ask your dealer about the lubricant analysis program, **Systemgard™**. Through this service, an independent laboratory tests your lubricants. You simply remove a sample of lubricant from your machine and send the sample to the **Systemgard™** laboratory. After the sample is processed, the laboratory will report back to you and guide you with maintenance requirements. **Systemgard™** can help support your equipment up time and provide you with a service that can pay back dividends when you trade for another piece of CASE CONSTRUCTION equipment.

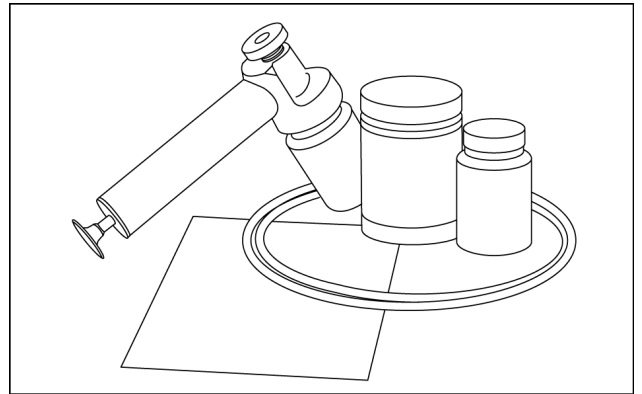

RCPH10TLB297AAF 1

Glow-plug Control Unit (GCU) fuse

1. Raise the loader arm and engage the safety support.
2. Lift the engine hood.
3. Locate the **60 A GCU fuse (2)** on the master disconnect mounting bracket.
4. Squeeze the two locking tabs **(1)** on the fuse box cover.
5. Remove the fuse and relay cover.
6. Only replace fuse and relay with the same type and amperage.
7. Install the cover until the two locking tabs lock into position.

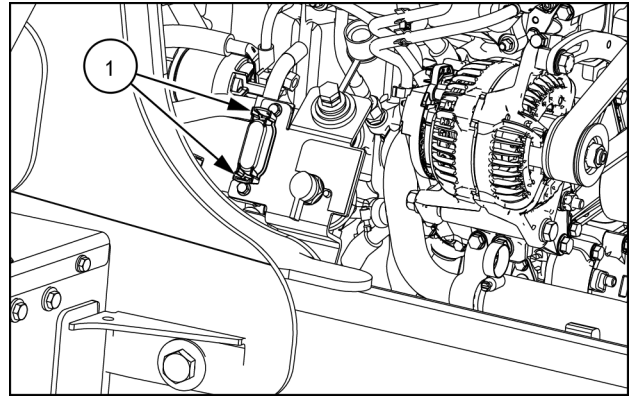

RAIL18TLB0388BA 9

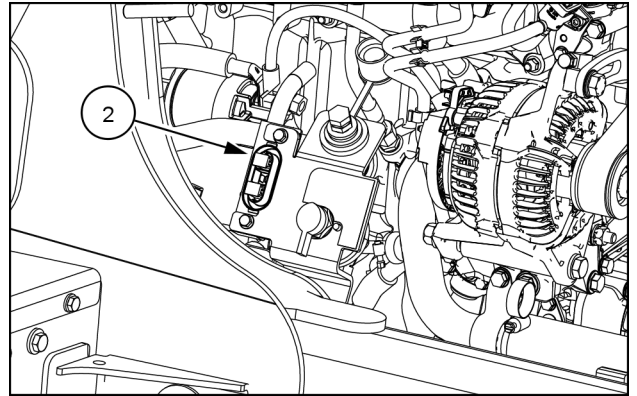

RAIL18TLB0389BA 10

Blower fuse (behind instrument cluster)

1. Remove the instrument cluster. If necessary, unplug the connectors on the back of the instrument cluster.

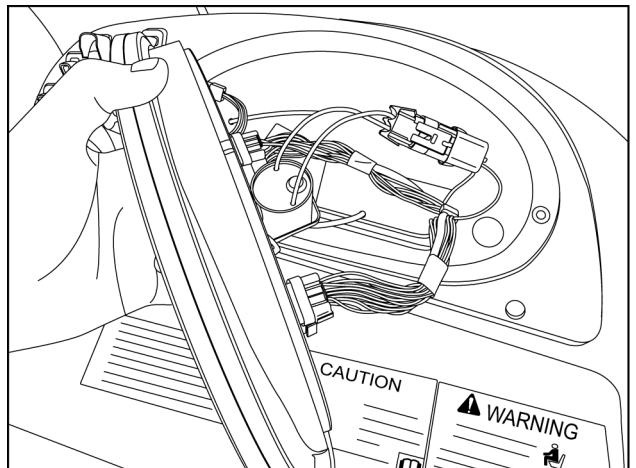

RAIL15TLB0007BA 11

NOTE: *STC® connectors are easily identified by the black ring (3) on the end of the connector.*

8. Use the tool (1) to disconnect **STC®** connectors. Insert the tool (1) between the rounded black ring (3) and metal sleeve (2) of the connector. This will release the two connectors from each other.
9. To connect **STC®** connectors. Remove the **STC®** tool (1) and press the male and female connectors together until the black ring snaps into place.

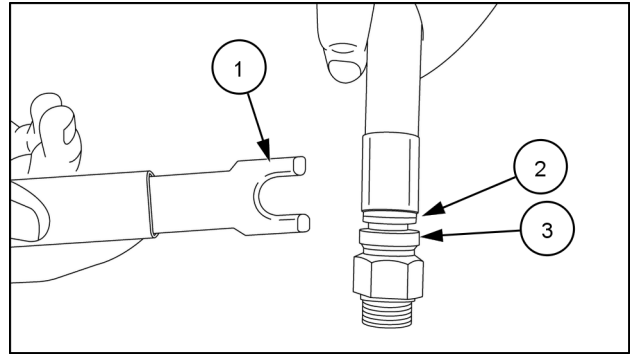

RAIL17TLB0517AA 3

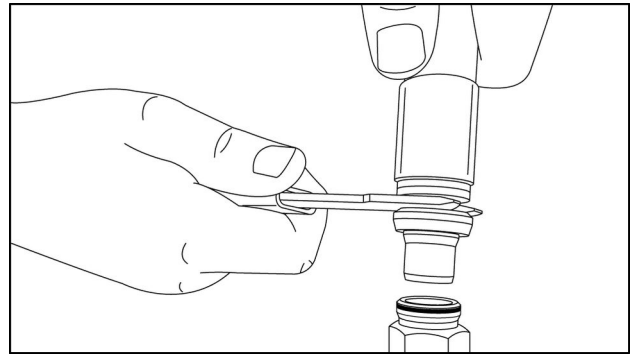

RAIL17TLB0520AA 4

Wheel nut and bolt torque

Check the torque of the wheel nuts and bolts at the first **10 h** of operation whenever a wheel is removed or for a new machine. If the nuts and bolts are loose, tighten and check after an additional **10 h** of operation. Repeat until the nuts and bolts remain tight.

Rear wheels

NOTICE: Tighten nuts in a crossing pattern (sequence), as shown.

Rear wheel:

1. Tighten the five mounting nuts in sequence until the wheel is snug against the axle hub.
2. Tighten the nuts in sequence to a torque of **136 N·m (100 lb ft)**.
3. Tighten the nuts a second time, in sequence, to a torque of **271 N·m (200 lb ft)**.
4. Tighten the nuts in sequence an additional **30°** to set the preload.
5. Repeat the procedure on the remaining five mounting nuts.

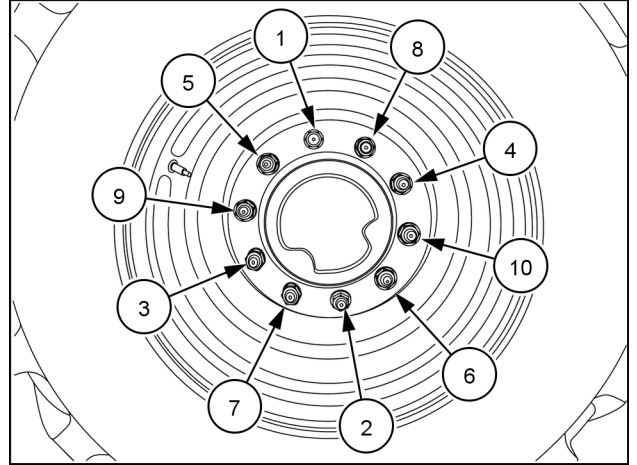

RAIL14FRK0031BA 1

Front wheels

NOTICE: Tighten bolts and washers in a crossing pattern (sequence), as shown. Four-Wheel Drive (4WD) axle shown but the sequence is the same for Two-Wheel Drive (2WD).

Front Two-Wheel Drive (2WD):

1. Tighten the eight mounting bolts with washers in sequence until the wheel is snug against the axle hub.
2. Tighten the bolts in sequence to:
 - For tire size 12 x 16.5 – **119 – 125 N·m (88 – 92 lb ft)**
 - For tire size 11 x 16 - **156 – 203 N·m (115 – 150 lb ft)**
3. For tire size 12 x 16.5. Tighten the bolts in sequence an additional **30°** to set the preload.

Front Four-Wheel Drive (4WD):

1. Tighten the eight mounting bolts in sequence until the wheel is snug against the axle hub.
2. Tighten the bolts in sequence to a torque of **119 – 125 N·m (88 – 92 lb ft)**.
3. Tighten the bolts in sequence an additional **43°** to set the preload.

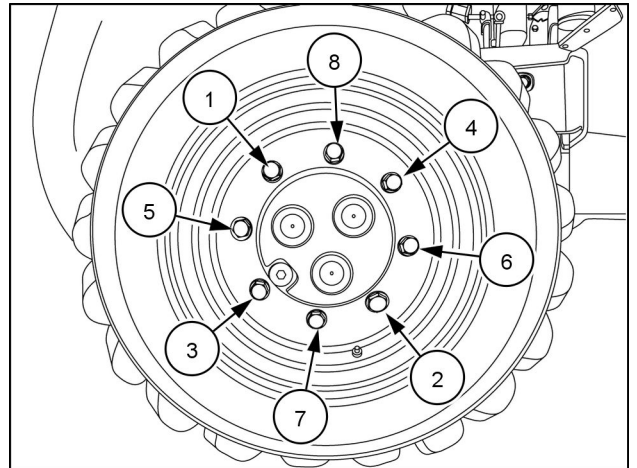

RAIL14FRK0032BA 2

(13) Dipper pivot - Two total, one on each side

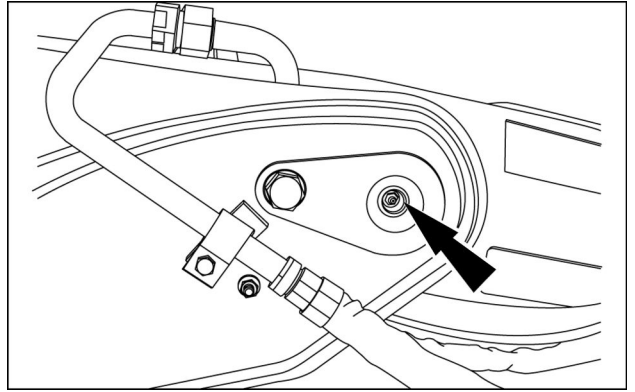

RCPH10TLB373AAF 22

(14) Dipper cylinder, closed end - One

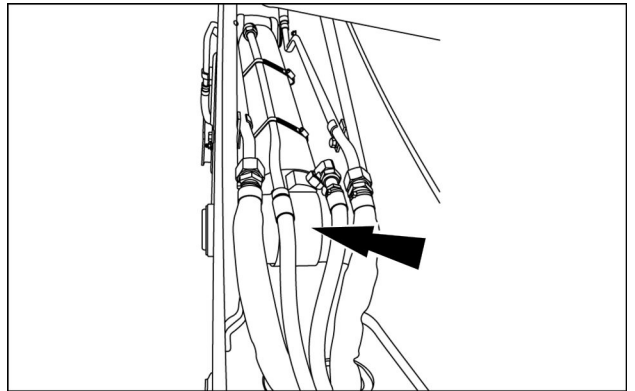

RCPH10TLB376AAF 23

(15) Boom pivot - Two total, one on each side

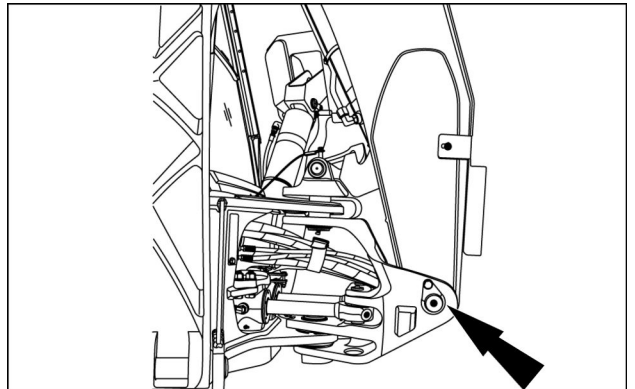

RCPH10TLB390AAF 24

(16) Swing cylinder, rod end - Two

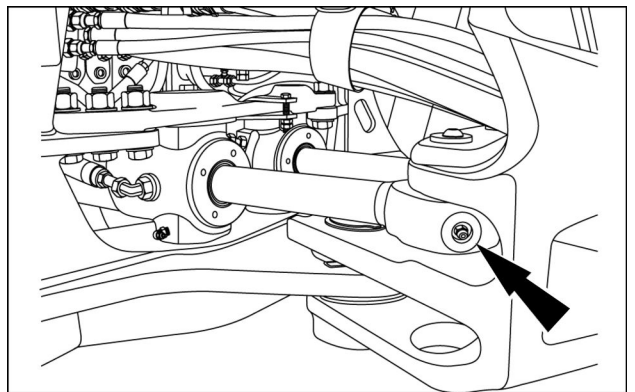

RCPH10TLB367AAF 25

Hydraulic reservoir fluid level

NOTICE: Oil quality and cleanliness are of utmost importance for the reliability and life of the hydraulic system. Deviation from the prescribed oil specification may lead to severe damage and void warranty.

Check the fluid level of the hydraulic system every **50 h** of operation or each week, whichever occurs first.

Hydraulic oil specification – **CASE AKCELA NEXPLORE™ FLUID**

Severe Cold Weather Package (SCWP) hydraulic oil specifications – **CASE AKCELA HY-TRAN® ULTRACTION SSL**.

1. Park the machine on level ground.
2. To ensure an accurate level reading:
 - Lower the loader bucket to the surface.
 - Put the backhoe in transport position.
 - Raise both stabilizers.
 - Allow the hydraulic fluid to cool.
3. Turn off the engine.
4. Move all hydraulic controls in each direction to relieve system pressure.
5. Check the gauge **(1)** on the hydraulic reservoir. The hydraulic reservoir is full when hydraulic fluid comes to the FULL COLD mark in the gauge.
6. Add hydraulic fluid as needed. Slowly turn the reservoir cap **(2)** to relieve pressure and then remove the cap.

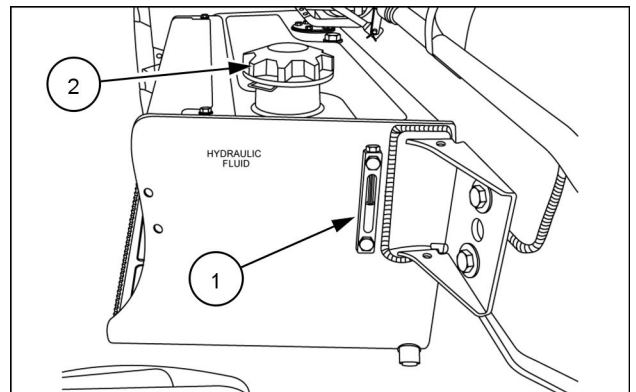

RCPH10TLB428AAF 1

Loader hydraulic coupler lock pins

If equipped, grease the lock pins for the hydraulic coupler every **50 h** of operation.

Grease specification – **TUTELA MULTI-PURPOSE EP GREASE 251H, GR-9**

Grease both fittings, one on each side.

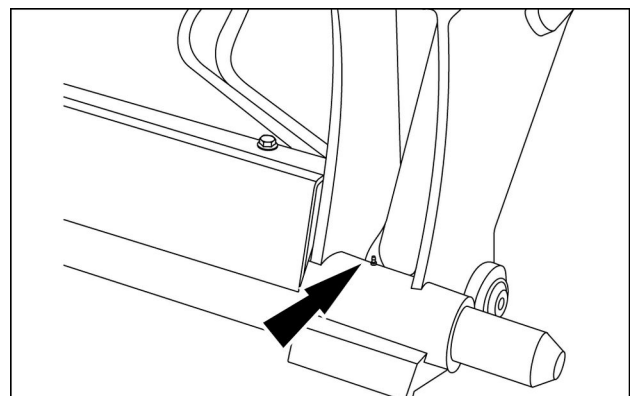

RCPH10TLB269AAF 1

Every 100 hours

Backhoe swing control

Grease the two fittings for the swing pedals, if equipped, every **100 h** of operation.

1. Remove the two plastic plugs on the backside of the backhoe control tower to access the fittings.
2. Wipe dirt and debris away from the fittings and around the area.
3. Grease the fittings with **TUTELA MULTI-PURPOSE EP GREASE 251H, GR-9** and insert the plastic plugs.

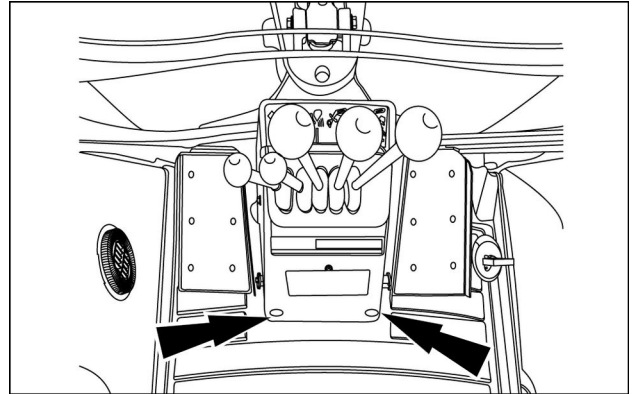

RCPH10TLB128AAF 1

Extendahoe control

Grease the fitting of the foot pedal control for the Extendahoe, if equipped, every **100 h** of operation.

1. Remove the plastic plug on the backside of the backhoe control tower to access the fitting.
2. Wipe dirt and debris away from the fitting and around the area.
3. Grease the fitting with **TUTELA MULTI-PURPOSE EP GREASE 251H, GR-9** and insert the plastic plug.

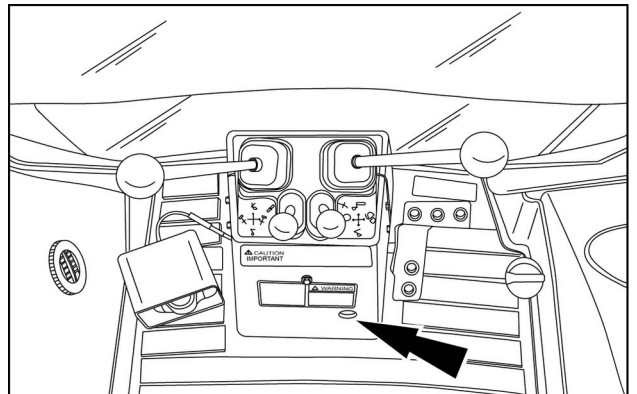

RAIL14TLB0702AA 1

Fuel filters

Replace the fuel filters after the first **100 h** of operation on a new machine or if a major component has been rebuilt. Then replace the fuel filters every **500 h** of operation or after a loss of engine power.

1. Fill the fuel tank before proceeding.
2. Open the fuel tank cap slightly to release pressure.
3. Clean the area around the water separator of dirt and debris.
4. Remove the wire connector at the base of the water separator.

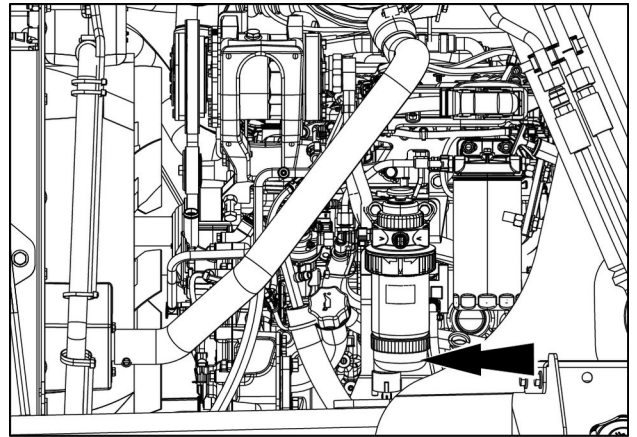

RAIL17TLB0350BA 1

- Press on the wire clasp that holds the connector to the drain to remove.

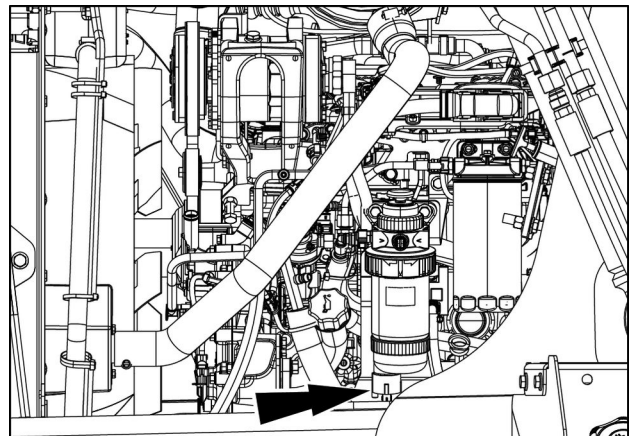

RAIL17TLB0350BA 2

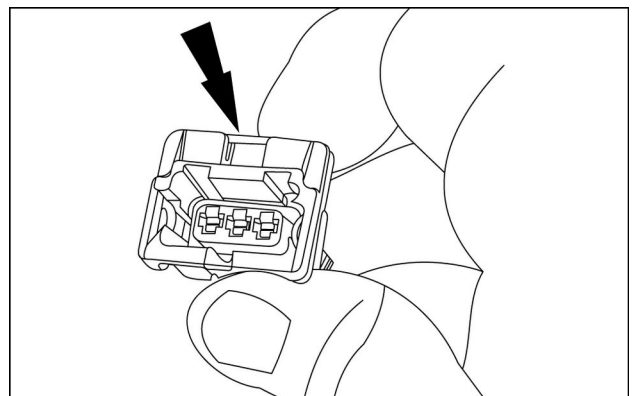

RCPH10TLB031AAF 3

Front axle fluid - Four-Wheel Drive (4WD)

Change the front axle fluid every **1000 h** of operation.

Axle and hub oil specification – **TUTELA TRANSAXLE FLUID SAE 80W-140**

Oil capacity – Differential **5.5 L (5.8 US qt)**. Each hub **0.53 L (0.56 US qt)**

1. Start up the engine and run until the front axle fluid is at operating temperature.
2. Use the loader and raise the front wheels about **25 mm (1 in)** above the surface.
3. Rotate both front wheels so that the oil level plug is in the drain position, as shown.

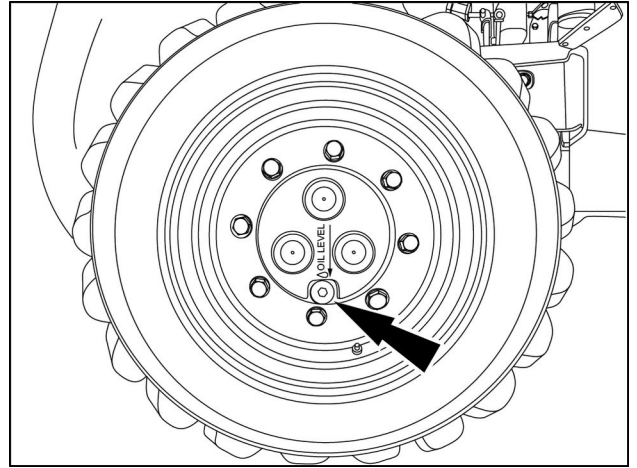

RAIL14FRK0089BA 1

4. Lower the loader to place the wheels on the surface.
5. Clean the areas around the planetary plugs.
6. Place a suitable container under the planetary drain plugs and slowly remove the plugs.
7. Clean the areas around the check/fill plug **(1)** and the drain plug **(2)** for the center bowl.
8. Slowly remove the check/fill plug.
9. Place a suitable container under the drain plug and slowly remove the plug.
10. After the oil has drained from the axle, install the drain plug.

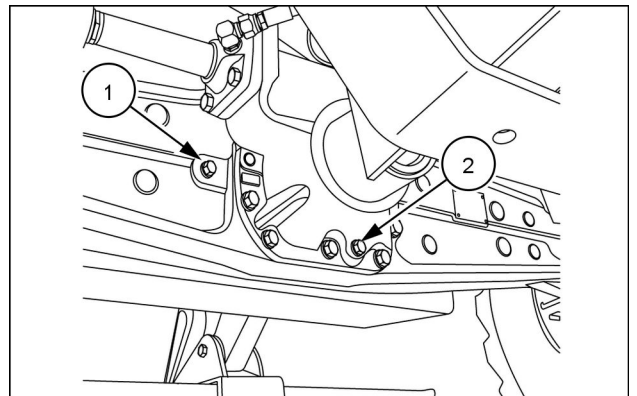

RCPH10TLB059AAF 2

11. Use the loader and raise the front wheels about **25 mm (1 in)** above the ground.

Every 4000 hours

Cooling system

⚠ CAUTION

Burn hazard!

Hot coolant can spray out if you remove the filler cap while the system is hot. After the system has cooled, turn the filler cap to the first notch and wait for all pressure to release before proceeding. Failure to comply could result in minor or moderate injury.

C0043A

NOTICE: NEVER mix OAT coolant with conventional coolant. Under no circumstances should you top off a cooling system with only water. You can use a refractometer to check the concentration level. Supplemental Coolant Additives (SCA) should not be used when using **CASE AKCELA ACTIFULL™ OT EXTENDED LIFE COOLANT**.

Drain, flush, and replace the engine coolant every **4000 h** of operation or every year, whichever comes first.

Coolant fluid specification: **CASE AKCELA ACTIFULL™ OT EXTENDED LIFE COOLANT**

Coolant fluid capacities:

Without heater **17.3 L (18.3 US qt)**. With heater **18.0 L (19.0 US qt)**

1. Park the machine on level ground.
2. Raise the loader arm and engage the safety support.
3. Shut down the engine and place a 'Do Not Operate' tag on the key switch.
4. Allow time for the engine and the coolant to cool.
5. Remove the six bolts (1) that secure the radiator bumpers (2) and remove the bumpers.

NOTE: Shown with optional chaff screen.

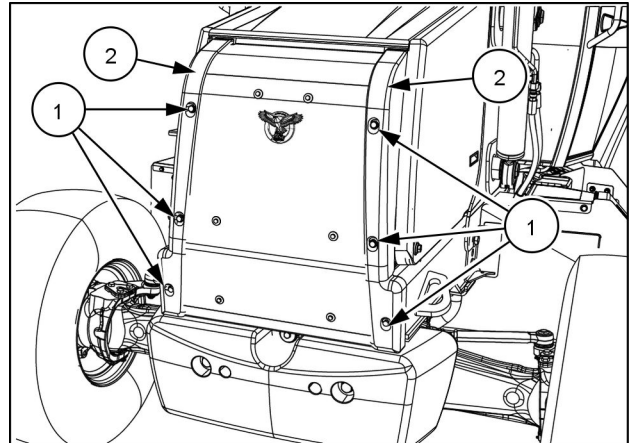

RAIL18TLB0398BA 1

6. Tip the grille up from the bottom and lift away from the machine.

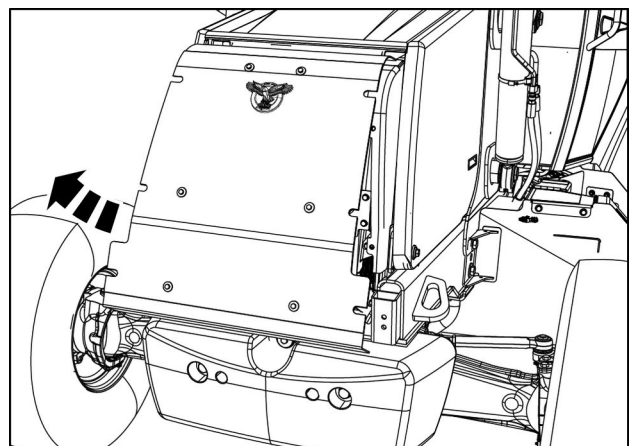

RAIL18TLB0398BA 2

Operator's seat

Check the condition of the seat cover and the moving parts. Clean or grease as needed.

- Clean the seat cover.
- Use **CNH IRON GARD GRAPHITE LUBRICANT NON-STICK** to grease the seat slides.
- Clean the bearing area. **DO NOT** grease the bearing area.
- Grease backrest tilt mechanism.
- Replace the armrest pads.

Seat cover

1. Brush and vacuum loose dirt.
2. Clean using cold water on cloth covers or warm soapy water on vinyl covers. If additional treatment is needed, use an automobile or home product cleaner for the same cover type.

NOTE: If alcohol based cleaners are used, on either cloth or vinyl, it is recommended to test a small area first.

Seat slides and bearing area

1. Use **CNH IRON GARD GRAPHITE LUBRICANT NON-STICK** to grease the seat slides (1).

NOTE: Air suspension seats are maintenance free. Do not lubricate.

NOTICE: Do not apply **CNH IRON GARD GRAPHITE LUBRICANT NON-STICK** to the bearing area. Use compressed air only to clear dirt and debris.

2. **CAUTION**

Eye injury hazard!
Wear protective goggles when using compressed air.
Failure to comply could result in minor or moderate injury.

C0035A

Use compressed air to keep the seat bearing area (2) clear of dirt and debris.

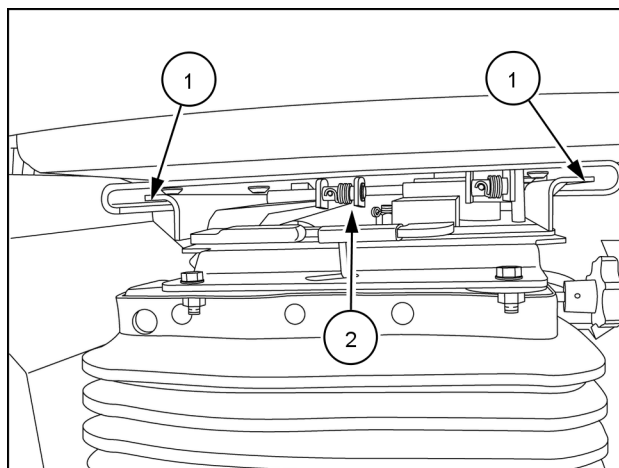

RAIL14UTL0051BA 1

Backrest tilt mechanism

1. Tip the backrest fully forward.
2. Grease the tilt mechanism on each side with **CNH IRON GARD GRAPHITE LUBRICANT NON-STICK**.

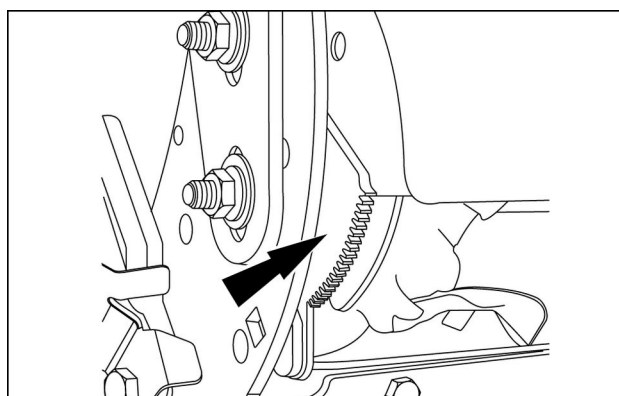

RCPH10TLB131AAF 2

Uni-directional auxiliary hydraulic pressure and flow

NOTE: Uni-directional attachments only.

NOTICE: Adjust the pressure and flow for the uni-directional auxiliary hydraulic valve (hammer valve) as needed to work within the parameters of the attachment.

NOTICE: Refer the information provided by the manufacturer of the attachment for the recommended operating pressure and flow.

Pressure adjustment

NOTE: The uni-directional auxiliary hydraulic valve is preset from the factory to approximately **103 bar (1500 psi)**.

1. For machines equipped with dual auxiliary hydraulics, ensure the auxiliary hydraulic control switch in the enabled for unidirectional control.
2. Install the swing lock pin to prevent accidental swing movement.
3. Remove the cap for the auxiliary hydraulic pressure port.
4. Install a pressure gauge capable of **207 bar (3000 psi)** in the pressure port. If needed, convert the male ORFS port to a snap-type connection. Contact your dealer for the correct CNH reducer, tube nut, and test port required to convert the connector to a snap-type connection.
5. Start up the engine.
6. Warm up the auxiliary hydraulics to **50 °C (120 °F)**:
 - Stall a function for **30 s** and then release the function. Repeat until temperature is reached.
7. While operating the uni-directional hydraulics, have another worker read the pressure on the gauge.

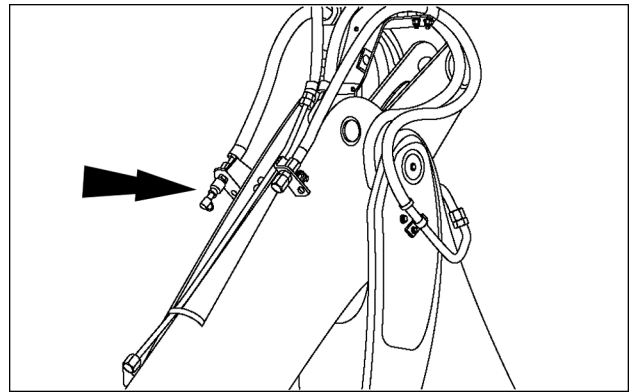

RCPH10TLB425AAF 1

8 - TROUBLESHOOTING

ALARM(S)

Seat switch alarm

The seat switch sounds when:

1. The direction control lever is in gear.
2. The seat is rotated approximately **15 – 20°** from the loader operation position towards the backhoe operation position.

NOTE: For machines with the electronic hand throttle, the engine is placed into idle if the seat is rotated while the engine is running.

Test the seat switch alarm:

1. Sit in the operator's seat, with the seat in the loader operation position and with the seat belt fastened.
2. Start the engine.
3. Park the machine on a level surface in a clean area. Make sure all other persons are clear of the area.
4. Make sure the parking brake is off, the transmission shift lever is in neutral and the loader bucket is on the ground.
5. Put your foot on the service brake and keep it there.
6. Place the direction control lever in forward and turn the seat approximately **15 – 20°**. The seat switch alarm sounds.
7. Place the direction control lever in reverse and turn the seat approximately **15 – 20°**. Both the seat switch alarm and the backup alarm sounds.
8. If the seat switch alarm does not sound, troubleshoot the alarm system.

9 - SPECIFICATIONS

Dimension	General purpose bucket	4-in-1 bucket
backhoe frame	314 mm (12.4 in)	
Stabilizer spread (transport position)		
flip pad	2140.0 mm (84.3 in)	
cast pad	2152.5 mm (84.7 in)	

Extendahoe® (retracted)

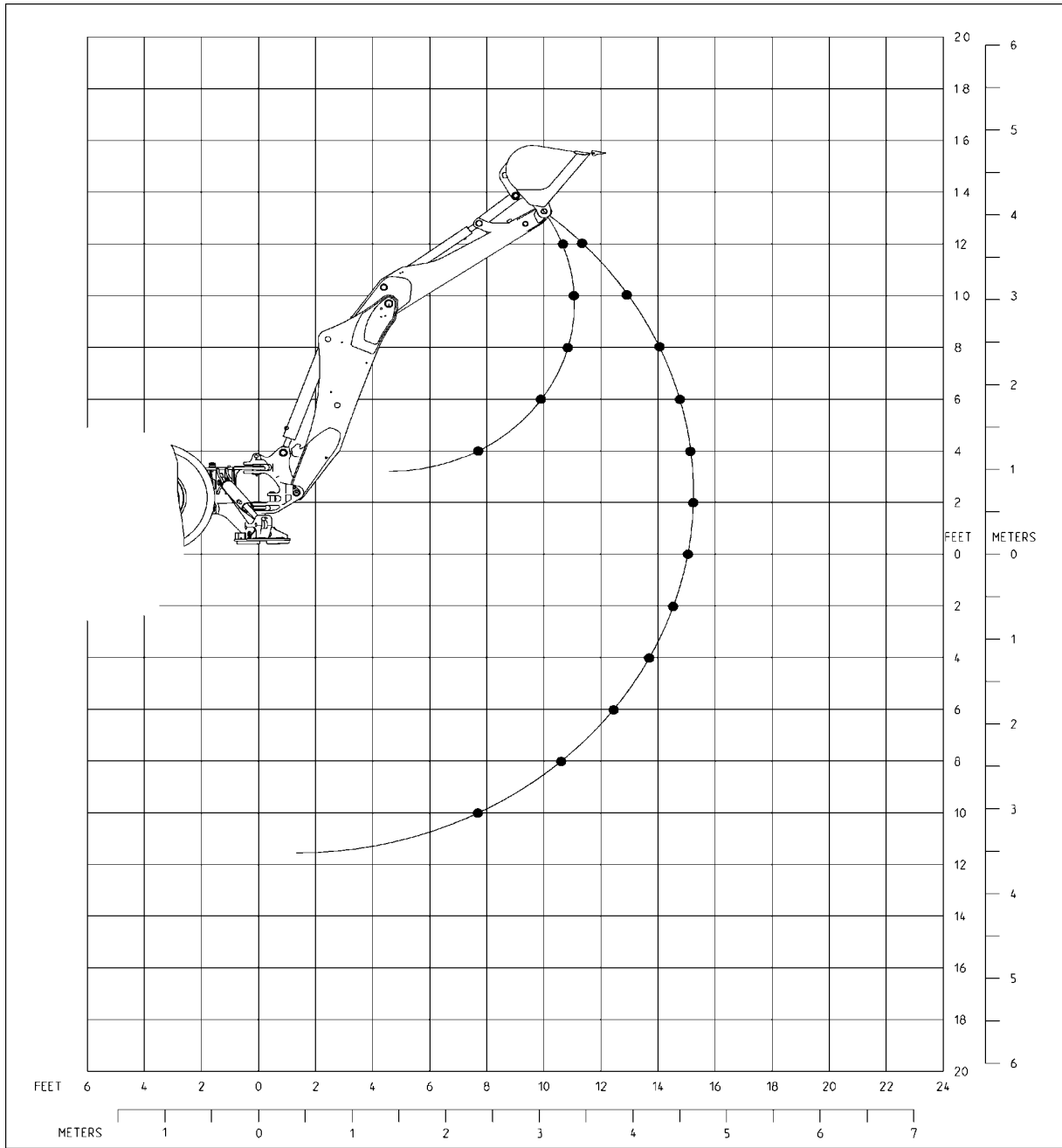

RAIL17TLB0066GA 3

NOTE: *Extendahoe® (retracted) with 610 mm (24 in) trenching bucket less coupler; nominal system pressure at 231 bar (3350 psi).*

NOTE: *Lift capacities are to be reduced by 79 kg (175 lb) when the 610 mm (24 in) Heavy Duty (HD) universal bucket, coupler, and links are used in place of the 610 mm (24 in) trenching bucket and links.*

CLICK HERE TO **DOWNLOAD** THE COMPLETE MANUAL

- Thank you very much for reading the preview of the manual.
- You can download the complete manual from: www.heydownloads.com by clicking the link below



- Please note: If there is no response to CLICKING the link, please download this PDF first and then click on it.

CLICK HERE TO **DOWNLOAD** THE COMPLETE MANUAL