

ORIGINAL INSTRUCTIONS - according to Directive 2006/42/EC, Annex I, 1.7.4.1

**521G**  
**Stage IV**  
Wheel Loader

**OPERATOR'S MANUAL**

**Part number 51418663**

1<sup>st</sup> edition English

November 2017



CLICK HERE TO **DOWNLOAD** THE COMPLETE MANUAL

- Thank you very much for reading the preview of the manual.
- You can download the complete manual from: [www.heydownloads.com](http://www.heydownloads.com) by clicking the link below



- Please note: If there is no response to CLICKING the link, please download this PDF first and then click on it.

CLICK HERE TO **DOWNLOAD** THE COMPLETE MANUAL

## Electro-Magnetic Compatibility (EMC)

This machine complies strictly with the European Regulations on the electro-magnetic emissions. However, interference may arise as a result of add-on equipment which may not necessarily meet the required standards. As such interference can result in serious malfunction of the unit and/or create unsafe situations, you must observe the following:

- Ensure that each piece of non- CASE CONSTRUCTION equipment fitted to the machine bears the CE mark.
- The maximum power of emission equipment (radio, telephones, etc.) must not exceed the limits imposed by the national authorities of the country where you use the machine.
- The electromagnetic field generated by the add on system should not exceed **100 V/m** at any time and at any location in the proximity of electronic components.

Failure to comply with these rules will render the CASE CONSTRUCTION warranty null and void.

## EC Declaration of Conformity

The following page provides a facsimile copy of the "EC" Declaration of Conformity. The EC Declaration of Conformity is the manufacturer's declaration about machine compliance to relevant EU provisions. Please keep the original document in a safe place. Local authorities may require you to show this document in order to assure compliance of your machine.

Translation of this declaration in your own country language is provided on the reverse page of the original document.

For your better and easier understanding of the document hereafter you'll find some explanatory notes.

1. QR code
2. Under section 1.2 are listed those options or variants which have safety related functions. Some of them are standard provided, like FOPS or ROPS.
3. Under section 2 are listed all information required by EU "Outdoor Noise" Directive **2000/14/EC**. Please refer your own original EC Declaration of Conformity for specific machine information.
4. Generic serial number for this machine type. Sequence of letters and numbers may vary depending on machine configuration.
5. EC Declaration of Conformity serial number. Please make reference to this number when requiring information or support about declaration.
6. Signature of a person authorized to sign the document on behalf of the company.

## Burn prevention

### **⚠ WARNING**

**Battery acid causes burns. Batteries contain sulfuric acid.**

**Battery electrolyte contains sulfuric acid. Contact with skin and eyes could result in severe irritation and burns. Always wear splash-proof goggles and protective clothing (gloves and aprons). Wash hands after handling.**

**Failure to comply could result in death or serious injury.**

W0120A

### **⚠ CAUTION**

**Burn hazard!**

**Hot coolant can spray out if you remove the filler cap while the system is hot. After the system has cooled, turn the filler cap to the first notch and wait for all pressure to release before proceeding.**

**Failure to comply could result in minor or moderate injury.**

C0043A

### **⚠ CAUTION**

**Burn hazard!**

**The engine and exhaust system become hot during operation. To prevent burns, open the engine compartment and allow the components to cool to a comfortable touch temperature before you work inside the engine compartment.**

**Failure to comply could result in minor or moderate injury.**

C0178A

- When the battery electrolyte is frozen, the battery can explode if you try to charge the battery or if you try to boost start and run the engine. To prevent the battery electrolyte from freezing, try to keep the battery at full charge. If you do not follow these instructions, you or others in the area can be injured.
- Hot coolant can spray out if the cooling system cap is removed. To remove the cap, let the cooling system cool, turn to the first notch, wait until the pressure is released, then remove the cooling system tank cap.
- Hot surfaces within the engine compartment can cause burns: the engine and the exhaust system will be very hot. To prevent burns, open the engine compartment and allow components to cool to comfortable touch temperature before working inside the engine compartment.

## 2 - SAFETY INFORMATION

Lower load or tool slowly



LEEN11T0016AA 12

Turn machine left swing load left  
To stop movement, stop moving hand and make a fist.

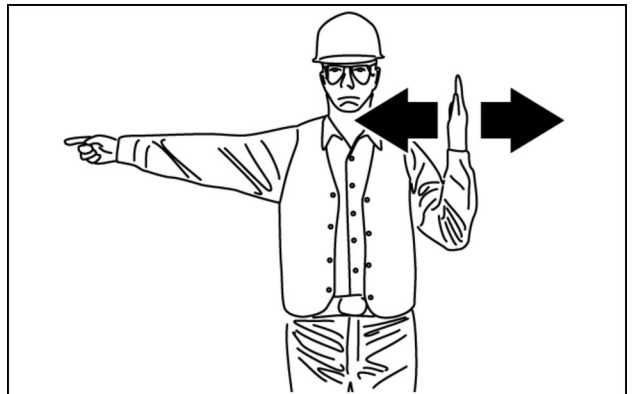

LEEN11T0017AA 13

Turn machine right swing load right  
To stop movement, stop moving hand and make a fist.

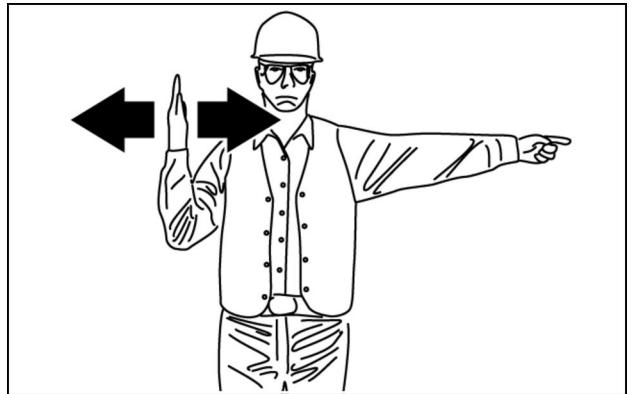

LEEN11T0018AA 14

Raise boom

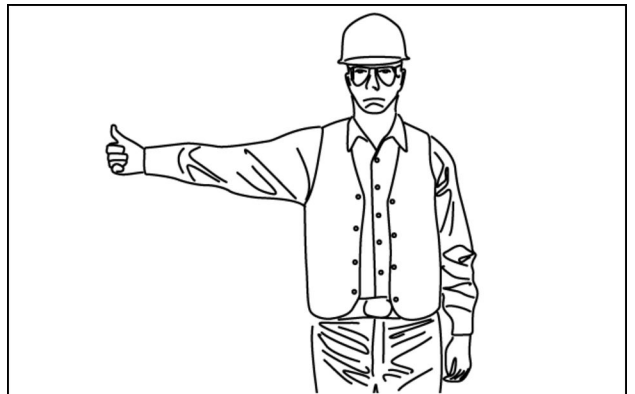

LEEN11T0019AA 15

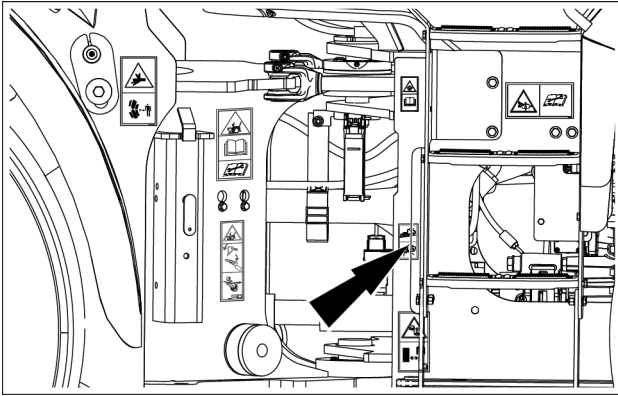

LEIL16WHL2272AA 19

Location: left-hand side of the machine, near the articulation area.

**WARNING**

Run-over hazard!

Block the wheels to prevent movement before disengaging the parking brake.

Failure to comply with this warning could result in death or serious injury.

ISO decal number: 329050A1

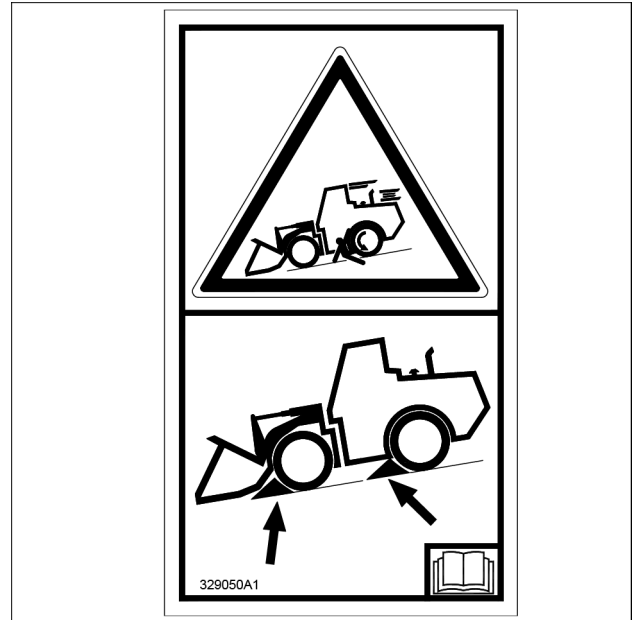

329050A1\_ 20

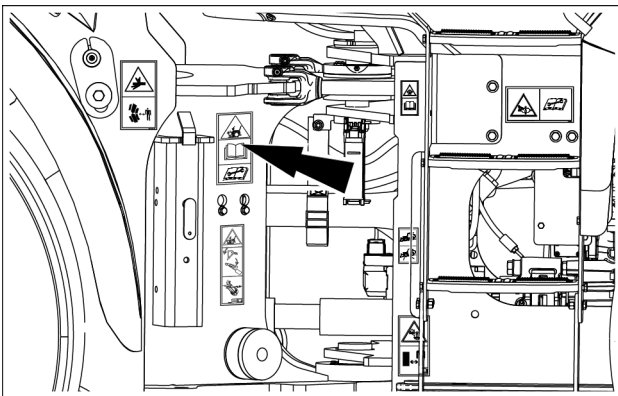

LEIL16WHL2272AA 21

Only installed if machine is equipped with Ride Control.

Location: left-hand side of the machine, near the articulation area (both sides of the frame plate).

**DANGER**

Crush hazard!

Servicing the valve will cause the lift arms to fall.

Failure to comply will result in death or serious injury.

ISO decal number: 87453136

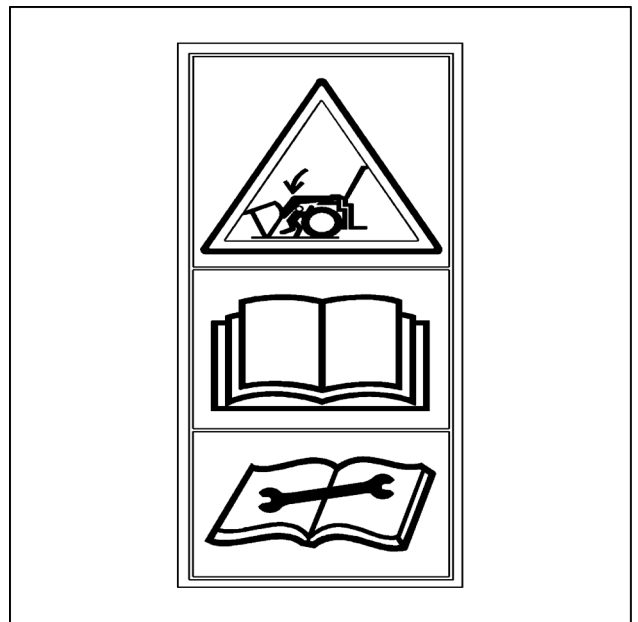

87453136 22

2 - SAFETY INFORMATION

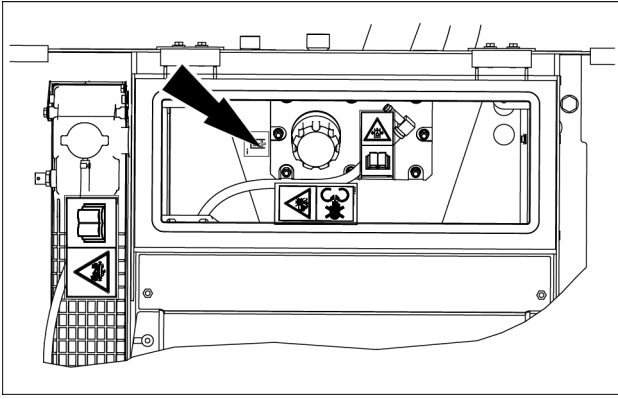

LEIL16WHL2273AA 59

Location: access compartment on the top of the machine, behind the cab.

Informational decal: hydraulic oil

ISO decal number: 395895A1

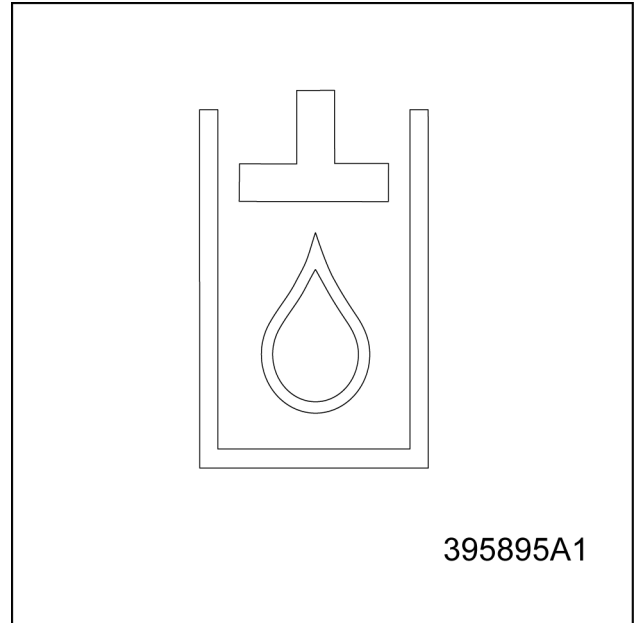

395895A1

395895A1 60

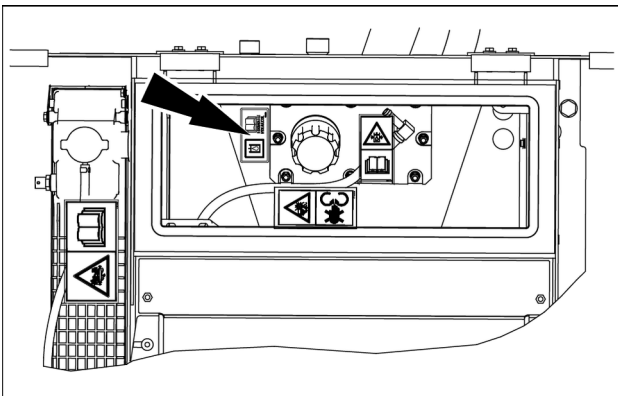

LEIL17WHL2063AB 61

Location: access compartment on the top of the machine, behind the cab.

**NOTE:** only with optional use of biodegradable hydraulic oil, the P/N 47482423 replaces the P/N 395895A1 decal.

Informational decal: biodegradable hydraulic oil

ISO decal number: 47482423

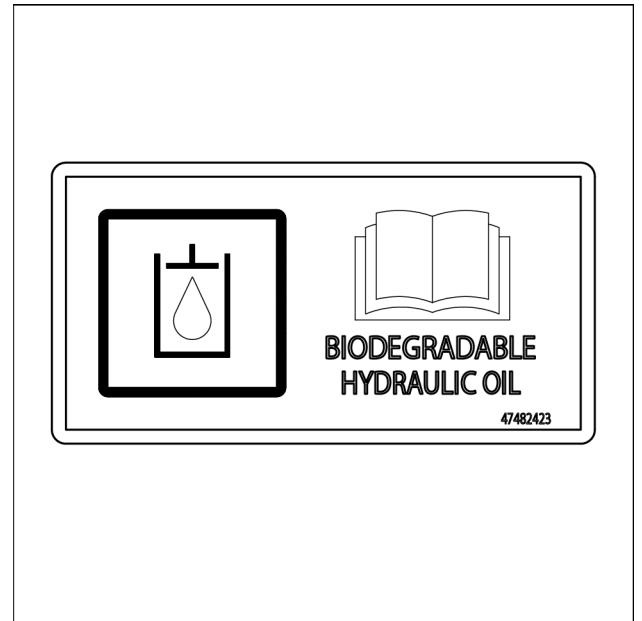

47482423\_A 62

## 3 - CONTROLS AND INSTRUMENTS

### Access to operator's platform

### Proper entry and exit

#### **⚠ WARNING**

**Fall hazard!**  
Clean the steps and access handles to remove all traces of grease, oil, mud, and ice (in winter).  
Failure to comply could result in death or serious injury.

W0139A

#### Steps and hand holds

Use the steps and hand holds to get down from or get onto the machine. Use at least three points of support to get on and off the machine. Lock the cab door into the full open or full closed position.

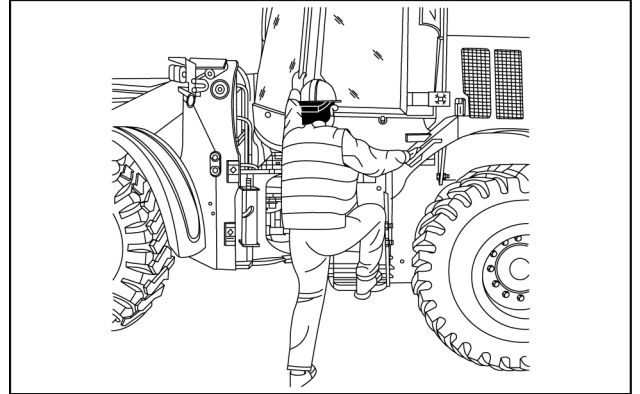

LEIL15WHL1811AA 1

#### **⚠ WARNING**

**Fall hazard!**  
Always lock the cab doors in the full open or full closed position before using the handrails on the doors.  
Failure to comply could result in death or serious injury.

W0133A

#### Cab door

Use the key to lock or unlock the cab door from outside the machine. Use the cab door handle to open the cab door from the outside.

To lock in place, open the cab door completely until the cab door latches in place against the cab.

**NOTICE:** lock the cab door into the full open or full closed position before using the door hand hold.

**NOTE:** the key provided with the machine can be used to lock and unlock the various panels and to activate the engine starter switch functions.

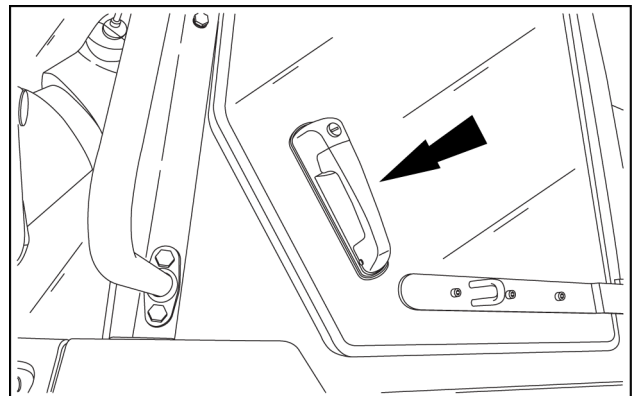

LEIL15WHL0502AA 2

### Lumbar adjustment

Turn the knob to adjust both the height and curvature of the backrest cushion.

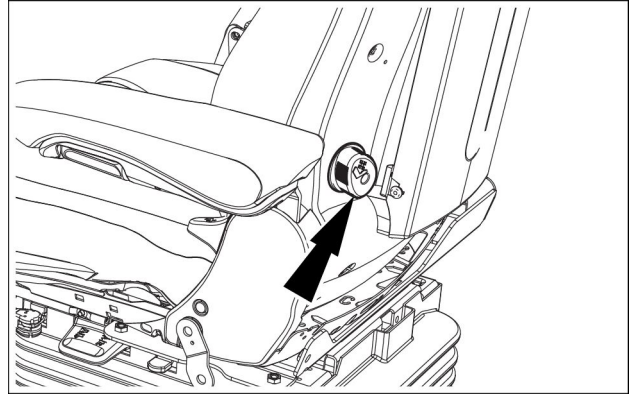

LEIL16WHL1401AB 26

### Seat heating

Use the rocker switch to activate the seat heating for cold weather comfort.

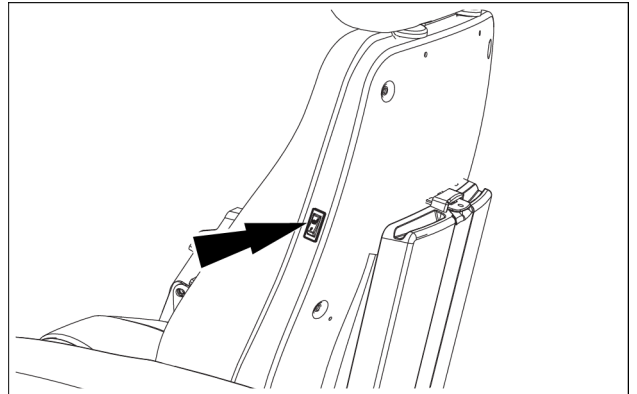

LEIL16WHL1402AB 27

### Headrest (Optional)

The seat is equipped at the top with provisions for optional headrest.

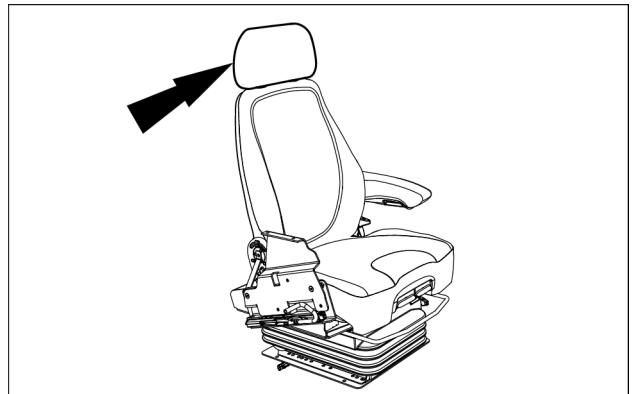

LEIL16WHL1392AB 28

### 1. Multifunction keypad

Refer to page "Multifunction keypad" – Chapter 3 in this manual to the multifunction keypad operations.

### 2. Ignition switch

The ignition switch has four positions:

- A. OFF position  
In this position, all switch controlled current is OFF. Turn the key to OFF to stop the engine. Remove the key and turn the timed disconnect switch to OFF.
- B. ACCESSORY position  
This position will energize the optional radio only. It will not energize the instruments or start the engine.
- C. ON position  
This position will energize all electrical systems. The key will return to this position after you release the key from the start position.
- D. START position  
Turn the key to this position to engage the starter motor to start the engine. The switch is spring loaded and will return to the ON position when released.

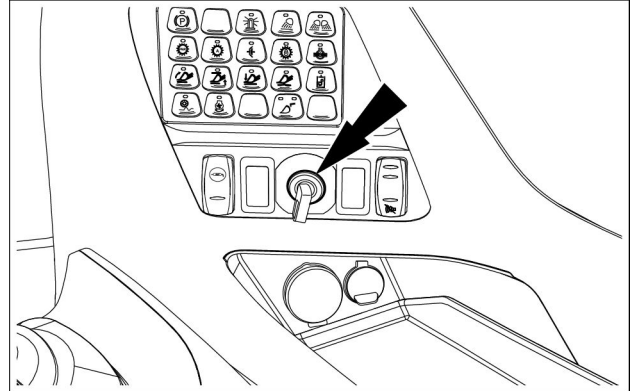

LEIL17WHL1588AB 2

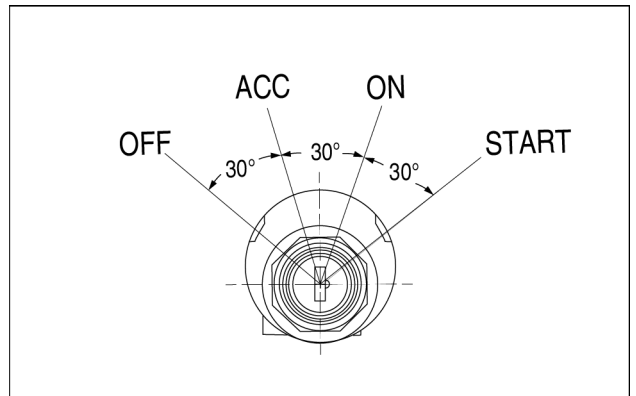

LEIL17WHL1446AA 3

### 3. Control lever (joystick)

Refer to page "Control lever operation" – Chapter 3 in this manual for the joystick/control lever operation.

### 4. Arm pad

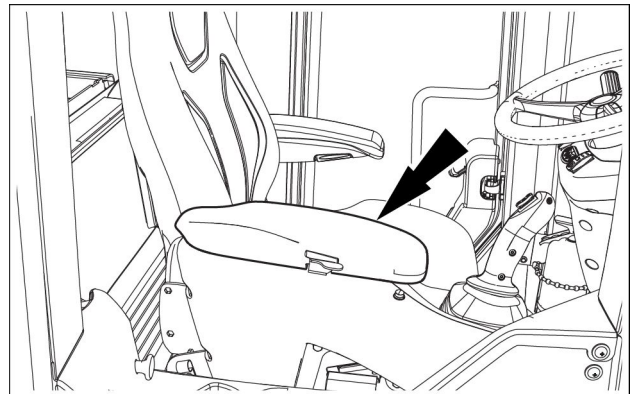

LEIL16WHL1304AB 4

**Four function valve - one control lever (joystick) with two auxiliary functions**

Lift arm and bucket control (1)

- A. DUMP
- B. ROLLBACK
- C. HOLD (central position) - The loader arms and bucket will not move when the control lever is in the HOLD position. When released, the control lever will automatically return to the HOLD position.
- D. FLOAT - When in the FLOAT position, the loader bucket floats across the rough ground.
- E. LOWER
- F. RAISE

Auxiliary control (2)

- G. AUXILIARY FUNCTION
- H. AUXILIARY FUNCTION

Auxiliary control (3)

- I. AUXILIARY FUNCTION (WITH DETENT)
- J. AUXILIARY FUNCTION (WITH DETENT)

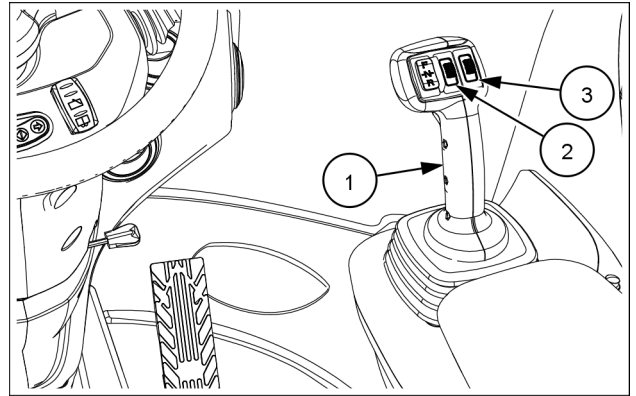

LEIL16WHL1290AA 9

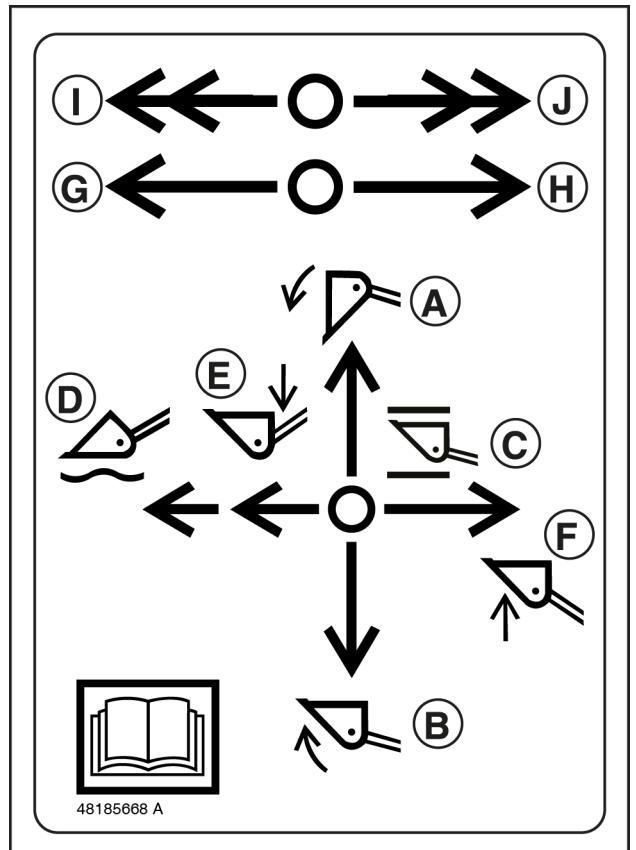

48185668\_C 10

**NOTE:** since the decal is applied on the right-hand side window, the directions are to be intended as follows:  
 D, E, G, I: Forward  
 F, H, J: Backward  
 A: Right-hand  
 B: Left-hand

## Battery isolator

1. The vehicle is equipped with a battery isolator that supplies battery power to the vehicle. The battery isolator is controlled by the vehicle controller and the timed disconnect switch located at the rear of the machine in the battery box.

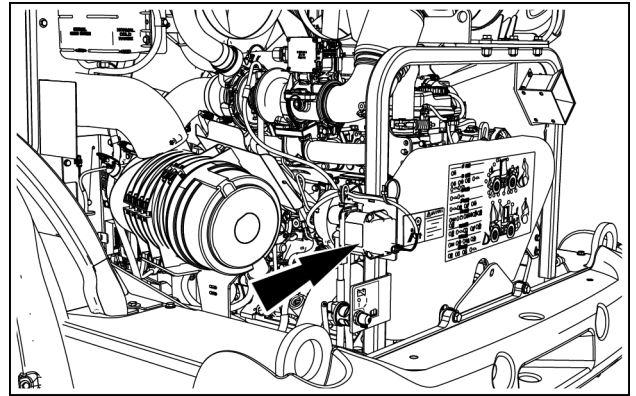

LEIL16WHL1166AA 6

2. The vehicle controller will turn ON the battery isolator with the following inputs:
  - Timed disconnect switch
  - Key switch
  - Door switch
3. Under normal operation when the timed disconnect switch is in ON position (switch closed) and the operator either opens the door or turns the key switch from OFF to ACC or ON position, the vehicle controller will turn ON the battery isolator.
4. The vehicle controller will turn OFF the isolator when the key switch has been in the OFF position for a period of time (about **5 min**) to allow vehicle functions to complete prior to turning OFF the battery isolator.
5. If the timed disconnect switch is in OFF position (switch open), the vehicle will not turn ON the battery isolator.
6. If the timed disconnect switch is in ON position (with the key in OFF position), but for **5 min** none of the actions before described is carried out or the machine is not used, the power supply is excluded through the UCM and the relays.  
To restore the power supply, switch to OFF position first and then switch back to ON position or turn the key to ON position.
7. The operator can hear an audible “click” when the battery isolator opens and closes.

→ Display selections

- Units
- Day Brightness
- Night Brightness

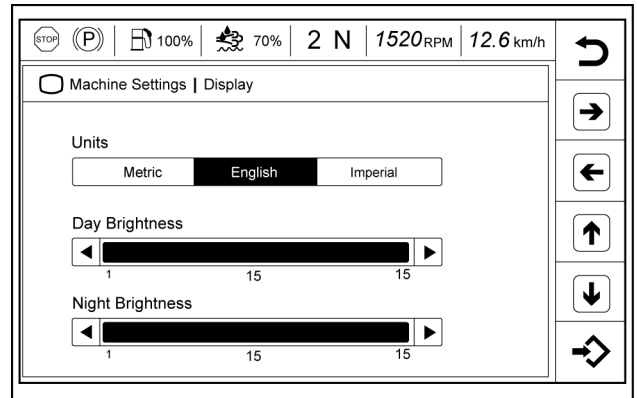

LEIL15WHL0529AA 21

Language

Date

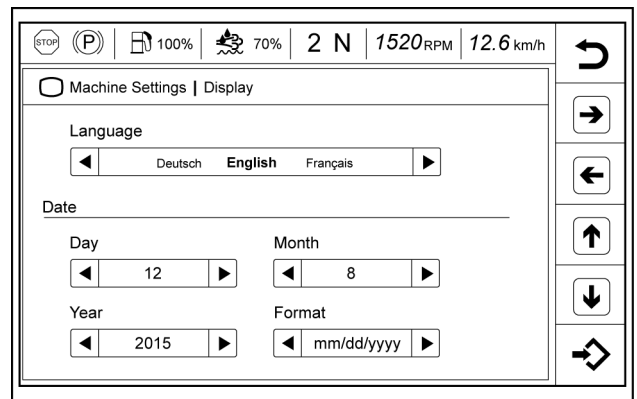

LEIL15WHL0530AA 22

Digital clock

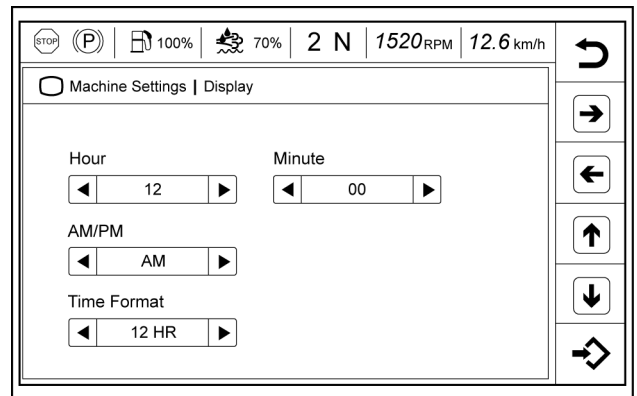

LEIL15WHL0531AA 23

### Fan

Use the keypad on the right-hand of the display to select the key to switch to the “Fan” settings.

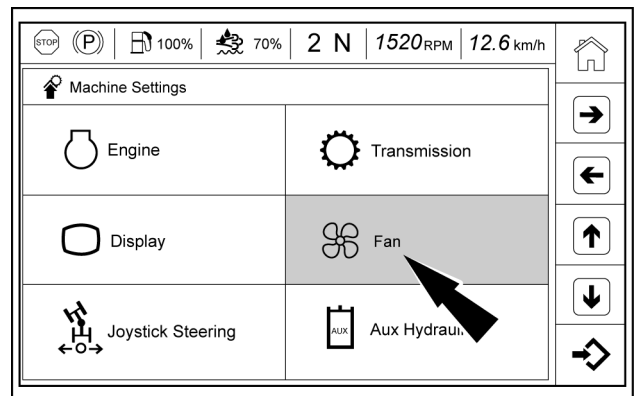

LEIL15WHL0635AA 24

→ Joystick Steering

- JSS Flow Command
- Steering Wheel Speed
- JSS Activation Switch
- JSS Armrest Switch
- JSS Joystick Position

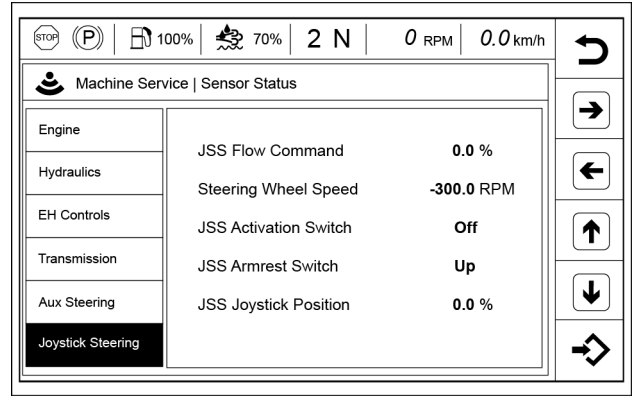

LEIL16WHL0895AA 57

**Calibration Settings**

Use the keypad on the right-hand of the display to select the key to switch to the “Calibration Settings” screens.

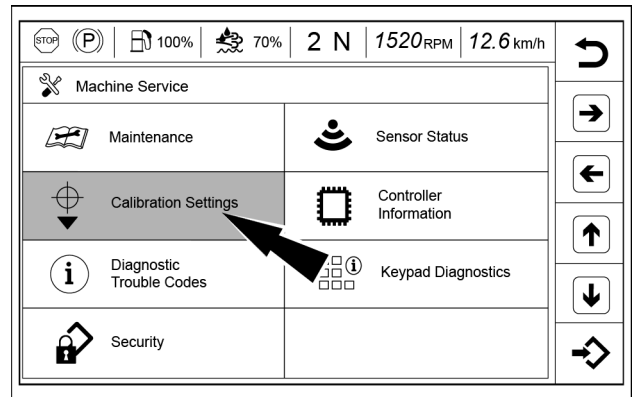

LEIL16WHL0874AA 58

→ Tire Size

- Tire Size
- Special (cm)

**NOTICE:** only for special Tire.

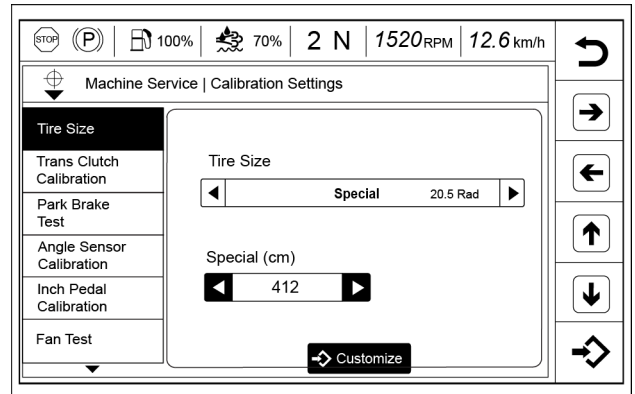

LEIL17WHL0951AA 59

→ Transmission Clutch Calibration

Conditions to be satisfied to start the transmission clutch calibration:

- Transmission Oil Temperature within range of **75 – 90 °C**
- Place Transmission in Neutral
- Turn on Parking Brake

Select “Start” to proceed with the transmission clutch calibration.

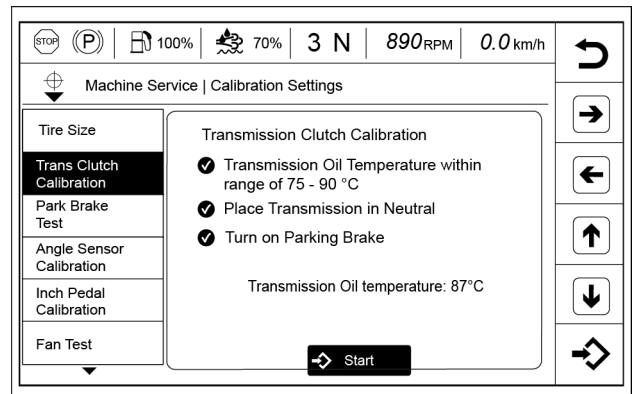

LEIL17WHL0952AA 60

### 3 - CONTROLS AND INSTRUMENTS

Access level summary

Features	Basic User	Advanced User	Administrator
Start Lockout	x	x	x
Trip computer	x	x	x
Machine Status Information	x	x	x
Machine Settings - Engine		x	x
Machine Settings - Transmission	x	x	x
Machine Settings - Display		x	x
Machine Settings - Fan		x	x
Machine Settings - Joystick Steering	x	x	x
Machine Settings - Aux Hydraulics		x	x
Machine Service - Maintenance			x
Machine Service -Sensor Status Info	x	x	x
Machine Service - Calibration Settings			x
Machine Service - Controller Information	x	x	x
Machine Service - Diagnostics	x	x	x
Machine Service -Security Code			x
Machine Service - Keypad Test	x	x	x
Camera View and Settings	x	x	x
Factory Setup menu			x

### 17. Engine coolant temperature gauge



The engine coolant temperature gauge indicates the coolant temperature of the engine. When the engine coolant temperature continues to increase and the gauge moves into the red zone, the warning alarm sounds continuously. The stop master indicator turns red. Do not operate the machine when the temperature is in the red zone.

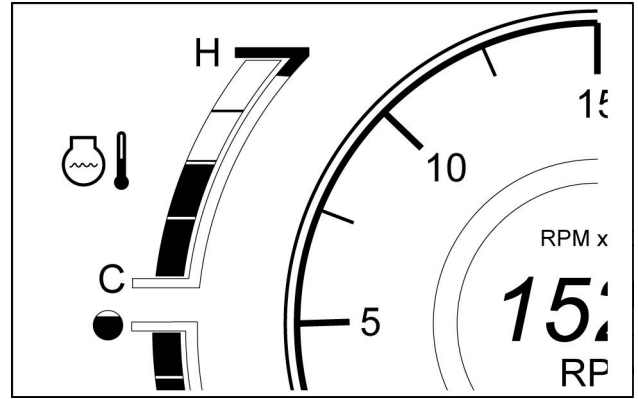

LEIL15WHL0576AA 5

### 18. Transmission oil temperature gauge

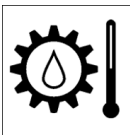

The transmission oil temperature gauge indicates the oil temperature of the transmission.

When the transmission oil temperature continues to increase and the gauge moves into the red zone, the warning alarm sounds continuously. The stop master indicator turns red. Do not operate the machine when the temperature is in the red zone.

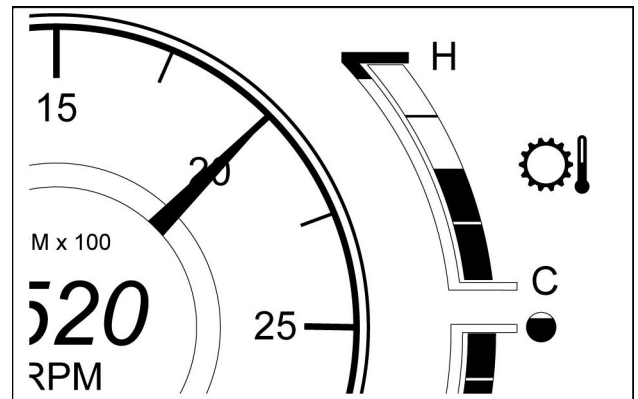

LEIL15WHL0577AA 6

**NOTE:** to prevent damage to the transmission, stop the machine, shift the transmission to NEUTRAL and run the engine at partial throttle (approximately 1700 RPM) until the transmission cools. If the transmission oil temperature does not return to normal operating temperature, run the engine at idle speed and check the transmission oil level. Correct the problem before continuing to operate the machine.

### 19. Fuel level gauge

#### ⚠ WARNING

**Pressurized hydraulic fluid can penetrate the skin and cause severe injuries.**

**If the machine runs out of fuel, do not attempt to work on pressurized hydraulic lines. Lines are under high pressure.**

**Failure to comply could result in death or serious injury.**

W0372A



The fuel level gauge indicates the fuel level. When the tank is almost empty, the gauge moves into the red zone, the fuel indicator turns on and the warning alarm sounds.

**NOTICE:** do not allow the machine to run completely out of fuel.

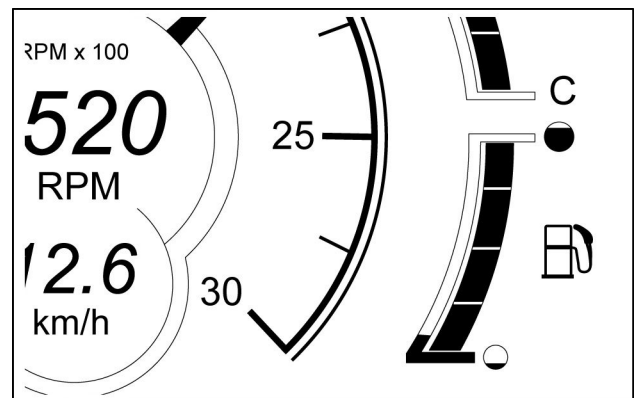

LEIL15WHL0578AA 7

## Starting the unit

### Starting the engine

#### **▲ WARNING**

**IMPROPER OPERATION OF THIS MACHINE CAN CAUSE DEATH OR SERIOUS INJURY.**

**MAKE SURE THAT EVERY OPERATOR:**

- is instructed in the safe and proper use of this machine.
  - reads and understands the operator's manual for this machine.
  - reads and understands **ALL** safety signs on the machine.
- Failure to comply could result in death or serious injury.

W0188A

#### Before operating the machine

Before operating this machine, complete the following procedures:

1. Check the level of all fluids (engine oil, fuel, transmission oil, **DEF/AdBLUE®**, hydraulic fluid, and coolant) and make sure that the fluids and lubricants are suitable for prevailing conditions.
2. Carry out the daily maintenance operations.
3. Inspect the machine, look for any signs of possible leakage and check the hoses. Tighten or replace as necessary.
4. See "Run-in period of a new machine" - Chapter 4 in this manual, if the machine is new or if the engine has been reconditioned.
5. Check the tires for any visible damage. Replace or repair as necessary. Check for correct tire air pressure and adjust the pressure if necessary.
6. Clean the steps and hand holds. Grease, oil, mud, or ice in winter on the steps and access handles can cause accidents. Keep the steps and the access handles clean at all times.
7. Clean or replace any decals which are illegible. See "Safety signs" - Chapter 2 in this manual for further information.
8. Make sure that the engine access panels and all doors are properly closed and latched.
9. Secure the cab door in either fully closed or fully opened position.
10. Remove any obstructions which hinder visibility. Clean the windshield, the windows and the rear view mirrors.
11. Check that no tools or other items have been left on the machine or in the operator's compartment.
12. Make sure no one is on or under the machine. The operator must be alone on the machine.
13. Make sure no one is standing in the machine working area.
14. Find out about current safety measures in use on the work site.
15. Work out a convenient means of escape from the machine (emergency exit via the windshield, the rear or side window glass) in the event of the cab door being jammed or the machine turning over.
16. Before undertaking any travel or working operations during hours of darkness, make sure the lighting and signaling equipment are fully operative.
17. Adjust the seat so that you can apply the foot brakes when your back is against the seat backrest.
18. Fasten and adjust the seat belt.
19. With the engine running and at operating temperature, check the instrument panel for correct indications.
20. Check the loader controls for correct operation.

## Ride control



Ride control is an optional feature that increases the ride comfort of the wheel loader over all types of terrain with either an empty or loaded bucket. Ride control allows faster speeds during operation, resulting in increased productivity and operator comfort. Ride control will also reduce shock loads to the wheel loader for reduced tire flex, structural fatigue and vibration, resulting in longer component life and reduced costs. Ride control will reduce fore and aft pitching motion during travel to allow faster speeds in load and carry applications.

The machine is equipped with a ride control switch (auto and off). Most commonly, the operator will choose to leave this switch in the automatic position. With ride control active, the green indicator light will illuminate. Anytime the machine is traveling faster than **5 km/h (3.1 mph)** ride control is functioning. Ride control will disengage automatically at slower speeds for loading and unloading.

To turn ride control OFF, press the ride control button until the LED light turns off.

**NOTE:** *turn ride control OFF when you operate the bucket in fine grading operations or when precision placement of a load suspended from the bucket or other attachment is required.*

## Loader functions

### Loader function buttons

1. Return-to-dig
2. Height control
3. Return-to-travel
4. Float

The green LED indicator lights up when the corresponding loader function is ON.  
Press the button to disengage all detents.

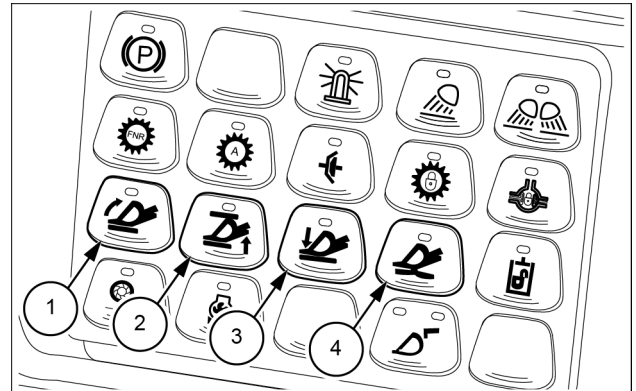

LEIL16WHL1128AB 1

### Return-to-dig

Use the return-to-dig function to automatically return the loader bucket to the dig position after you have dumped the loader bucket. To enable the return-to-dig function press the button **(1)**.

The green LED indicator lights up to indicate that the function is active.

To set the return-to-dig function proceed as follows:

1. Press the corresponding button **(1)** on the multifunction keypad to activate the function; the green LED indicator lights up to indicate that the function is active.
2. Set the attachment or the bucket to the desired location.
3. Press and hold the corresponding button **(1)** on the multifunction keypad until the green LED indicator light flashes (approximately **2 s**).
4. The return-to-dig function is now set. Display will prompt that the detent position is saved.

To actuate the return-to-dig function, move the joystick into the ROLLBACK position until the function activation point is reached. When the function activation point is reached, the operator will notice more resistance from the joystick. If released, the joystick will automatically return to the HOLD (central) position and the bucket will continue to rollback until it reaches the desired return-to-dig position. If you move the joystick when the return-to-dig function is activated, the bucket will stop.

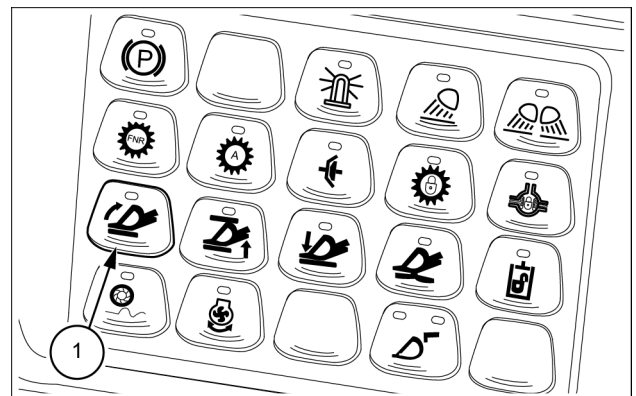

LEIL16WHL1129AB 2

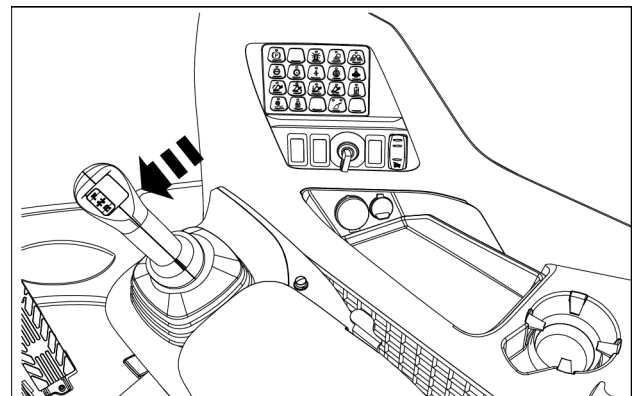

LEIL17WHL1454AB 3

## 5 - TRANSPORT OPERATIONS

### Road transport

### Safety rules

**▲ WARNING**

**Crushing hazard!**  
Engage the safety lock link before service or transport.  
Failure to comply could result in death or serious injury.

W0154A

**▲ WARNING**

**Driving hazard!**  
Know all rules, regulations, laws, and required safety equipment for transporting or operating this machine on a road or highway. See your dealer to obtain a rotating beacon, backup alarm, Slow Moving Vehicle (SMV) emblem, and other safety equipment.  
Failure to comply could result in death or serious injury.

W0154A

**▲ WARNING**

**Transport hazard!**  
The machine can slip or fall from a ramp or trailer. Make sure the ramp and trailer are not slippery. Remove all oil, grease, ice, etc. Move the machine on or off the trailer with machine centered on the trailer or ramp.  
Failure to comply could result in death or serious injury.

W0152A

**▲ WARNING**

**Transport hazard!**  
Always use the primary steering when loading or unloading the machine for transport. Do not use joystick steering when loading or unloading the machine from a truck or trailer.  
Failure to comply could result in death or serious injury.

W0448A

Make sure you know the safety rules and regulations before transporting the machine. You must know the rules or laws for transportation and safety that are used in each

area that you will be in. Make sure that the truck and machine are equipped with the correct safety equipment.

## Moving a disabled machine

### ⚠ WARNING

#### Misuse hazard!

Towing is a delicate maneuver that is always carried out at the risk of the user. The manufacturer's warranty does not apply to incidents or accidents that occur during towing. Where possible, carry out the repairs at the site.

Failure to comply could result in death or serious injury.

W0286A

### ⚠ DANGER

#### Loss of control hazard!

Make sure you use a towing vehicle with adequate weight. Towing with an underweight vehicle could cause a loss of control during transport or braking. Calculate the minimum towing vehicle weight required as instructed in this manual.

Failure to comply will result in death or serious injury.

D0049A

## Engine stalls while traveling

The operator can apply the brakes by pressing the pedal for four or five applications until the accumulator is discharged. The operator must limit the use of the brakes in this situation. If the brakes cannot be applied by the pedal, apply the parking brake.

The steering effort increases when the hydraulic system loses power. If the engine stalls while traveling, park the loader in a safe position and find the problem.

## Engine or hydraulic failure

If your machine is disabled, you must judge if the machine can be moved without further damage. If possible, repair the machine at the job location.

If you cannot repair the machine at the job location and if you have a transport trailer, park the trailer as close as possible to the machine.

## Never tow the machine from the front

Attach a rigid draw-bar to the machine.

**NOTICE:** make certain the towing machine has adequate brake capacity to safely stop both machines.

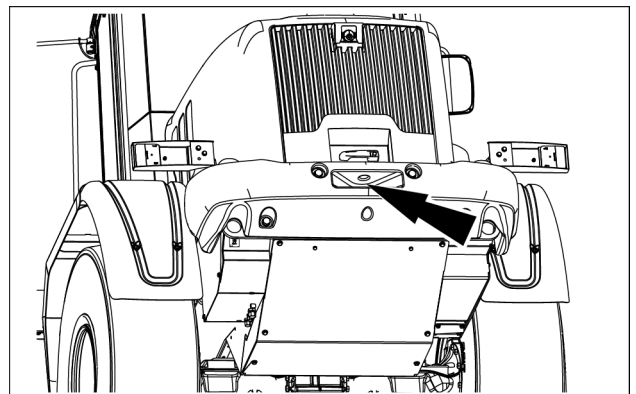

LEIL16WHL2271AA 1

CLICK HERE TO **DOWNLOAD** THE COMPLETE MANUAL

- Thank you very much for reading the preview of the manual.
- You can download the complete manual from: [www.heydownloads.com](http://www.heydownloads.com) by clicking the link below



- Please note: If there is no response to CLICKING the link, please download this PDF first and then click on it.

CLICK HERE TO **DOWNLOAD** THE COMPLETE MANUAL

4. After visually inspecting the locking pins to ensure they are fully retracted, rest the attachment firmly and safely on the ground.

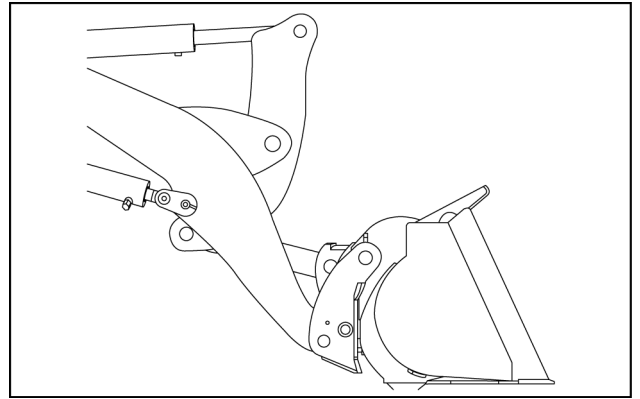

LEIL15WHL1832AA 4

5. Roll the coupler forward and down, while slowly backing away from the attachment, to remove the upper male portion of coupler from upper female portion of attachment.

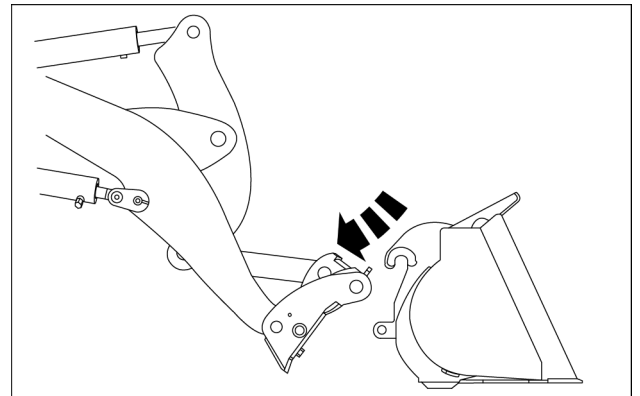

LEIL16WHL0038AA 5

## Releasing pressure in the hydraulic system

### ⚠ WARNING

Pressurized hydraulic fluid can penetrate the skin and cause severe injuries. Hydraulic fluid is under extreme pressure. Rest the bucket or attachment on the ground. Shut the engine off, turn the key on, and move the hydraulic control lever through all movements several times to relieve residual pressure in the system. Failure to comply could result in death or serious injury.

W0161A

### ⚠ WARNING

**Escaping fluid!**  
Hydraulic fluid or diesel fuel leaking under pressure can penetrate the skin and cause infection or other injury. To prevent personal injury: Relieve all pressure before disconnecting fluid lines or performing work on the hydraulic system. Before applying pressure, make sure all connections are tight and all components are in good condition. Never use your hand to check for suspected leaks under pressure. Use a piece of cardboard or wood for this purpose. If injured by leaking fluid, see your doctor immediately. Failure to comply could result in death or serious injury.

W0178A

### ⚠ WARNING

**Escaping fluid!**  
Do not disconnect hydraulic quick coupler under pressurized conditions. Make sure all hydraulic pressure is removed from the system before disconnecting hydraulic quick coupler. Failure to comply could result in death or serious injury.

W0095A

### ⚠ WARNING

**Burn hazard!**  
Before performing any service on the hydraulic system, you must allow it to cool. Hydraulic fluid temperature should not exceed 40 °C (104 °F). Failure to comply could result in death or serious injury.

W0241A

1. Park the machine on firm, level ground, lower the bucket/attachment to the ground and stop the engine.
2. Keep all non-authorized personnel clear of the machine. Turn the ignition switch key to the "ON" position.

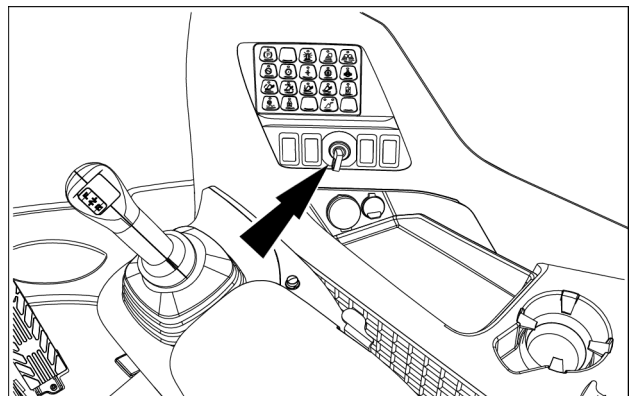

LEIL16WHL1286AA 1

If hydraulic fluid seeps into the ground, the machine owner and the authorities responsible must be informed.

PANOLIN HLP SYNTH VG 46 is suitable only for use in hydraulic systems.

As PANOLIN HLP SYNTH VG 46 is not soluble in water, condensed water may be deposited in the hydraulic fluid tank.

Condensed water must therefore be drained off at regular intervals and after lengthy downtimes, then disposed of in the same way as used oil.

Use only PANOLIN HLP SYNTH VG 46 for changing or topping up the hydraulic fluid.

The hydraulic fluid may not be mixed with hydraulic fluids or hydraulic fluids from other manufacturers, as this reduces its biodegradability.

Operating equipment and attachments operated with mineral hydraulic fluid must not be mounted until thoroughly emptied, cleaned, and flushed.

Analysis will show whether the hydraulic fluid can be used beyond the standard changing intervals.

See also **Hydraulic systems - Check**.

### **Transmission component oil**

Extreme pressure oil must be used for enclosed transmission components. Choose an oil that is manufactured for your climate/temperature conditions such as **CASE AKCELA NEXPLORE™ FLUID**. See the charts at the beginning of this section.

### **Front and rear axle oil**

Extreme pressure oil must be used for enclosed axle components. Choose an oil that is manufactured for your climate/temperature conditions such as **CASE AKCELA TRANSAXLE FLUID 80W-140**.

### **Grease**

**CASE AKCELA MOLY GREASE.**

### **Environment**

Before you service this machine and dispose of oil, fluids, and lubricants, obey environmental regulations. Do not drain oil or fluids on to the ground or into containers that leak. Check with your local environmental, recycling center or your dealer for correct disposal information.

**Caution master indicator (yellow, non-critical)**

The caution master indicator is a non-critical warning display. See the “Non-critical warnings” table. When the caution master indicator is ON, change the operating method, schedule a shutdown for maintenance, or if the condition persists, contact your dealer.

The “Non-critical warnings” table lists warning displays that may appear on the instrument cluster and the corrective action required.

**NOTICE:** when a fault occurs, an audible alarm may sound and the Caution Master Indicator will be yellow. The caution message will be displayed in the message area. If this occurs, return the machine to a service position, and turn the engine off, and take corrective action to help avoid expensive repairs.

**Non-critical warnings**

Display	Description	Corrective action
DEF/AdBLUE® Level LOW	DEF/AdBLUE® level is less than <b>10%</b> of tank volume. No engine power loss at this level	Fill the DEF/AdBLUE® tank.
Poor DEF/ AdBLUE® quality detected	Poor DEF/AdBLUE® quality/concentration detected. After the engine has run for <b>50 min</b> with poor DEF/AdBLUE® quality, there will be a torque and speed reduction.	Drain the tank. Replace DEF/AdBLUE®. <b>NOTE:</b> see “DEF/AdBLUE® tank refilling” section for important tank draining information.
DEF/AdBLUE® Injection Failed, Power Limited	Technical failure detected. <b>25%</b> torque reduction ramped in within <b>25 min</b> . Further torque/speed reduction <b>2 h</b> after initial fault detection if fault does not heal.	Contact your authorized dealer.
Fuel	Low fuel	Fill the fuel tank - do not allow the tank to totally empty.

## Selective Catalytic Reduction (SCR) system description

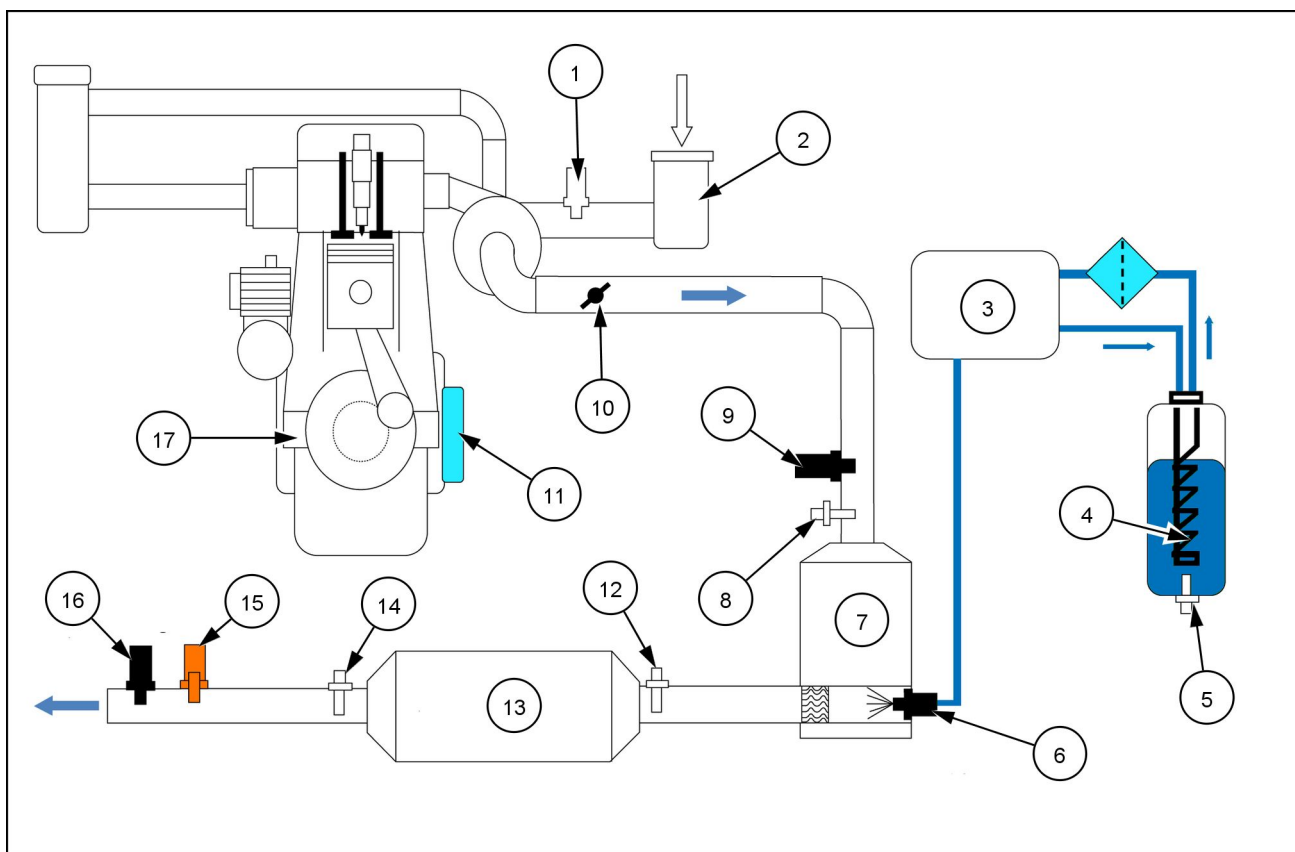

NHIL13ENG1393AA 5

- |  |   |
|--|---|
| (1) Intake air humidity and temperature sensor | (10) Exhaust flap                                 |
| (2) Air filter                                 | (11) Engine Control Unit (ECU)                    |
| (3) Supply module                              | (12) SCR upstream temperature sensor              |
| (4) DEF/AdBLUE® level and temperature sensor   | (13) Selective Catalytic Reduction (SCR) catalyst |
| (5) DEF/AdBLUE® quality sensor                 | (14) SCR downstream temperature sensor            |
| (6) Dosing module                              | (15) NH <sub>3</sub> sensor                       |
| (7) DOC and mixer                              | (16) Downstream NO <sub>x</sub> sensor            |
| (8) DOC upstream temperature sensor            | (17) Engine                                       |
| (9) Upstream NO <sub>x</sub> sensor            |   |

The humidity in the intake to the engine (17) affects the emissions in the exhaust stream. The intake air humidity sensor (1) is located in the intake air piping to the engine between the air filter (2) and the intake manifold. The information from this sensor is sent directly to the Engine Control Unit (ECU) (11).

Engine exhaust system temperature is critical to the catalytic reactions that take place in the emissions control components. To quickly increase the catalyst temperature at initial start-up and light operating loads, there is an exhaust flap (10) located in the exhaust stream near the turbocharger. The maximum temperature of the exhaust flap is critical, therefore engine coolant is circulated through the core of this valve. Limiting NO<sub>x</sub> emissions in the exhaust stream is one of the major goals of the emission control system on these engines. The upstream NO<sub>x</sub> sensor (9) is located in the exhaust stream at the inlet to the Diesel Oxidation Catalyst (DOC) (7). The NO<sub>x</sub> sensor transmits data to the ECU via the engine CAN data bus.

A temperature sensor (8) is located at the inlet to the DOC to closely monitor temperature.

DEF/AdBLUE® fluid freezes at **-11 °C (12 °F)**. A DEF/AdBLUE® fluid level and temperature sensor (4) is installed in the tank and the instrument cluster displays those levels. The DEF/AdBLUE® quality sensor (5) monitors the quality of the DEF/AdBLUE® fluid.

To precisely control the quantity of DEF/AdBLUE® fluid injected from the DEF/AdBLUE® tank into the exhaust stream, a DEF/AdBLUE® dosing module (6) is integrated in the outlet area of the DOC canister. The dosing valve is Pulse Width Modulation (PWM) controlled by the ECU. The ECU determines the amount of DEF/AdBLUE® fluid to inject based on inputs from sensors in the exhaust stream. Pressurized DEF/AdBLUE® fluid is supplied to the dosing module from the supply module (3) at approximately **9 bar (130 psi)**.

## Maintenance planning

## Maintenance chart

Maintenance action	Change fluid				Replace				Page no.
	Check	Grease			Cleaning	Drain fluid			
Daily inspection									
Daily inspection	x								7-45
Every 10 hours									
Engine oil level - Check	x								7-49
Every 50 hours									
Bucket/attachment fittings - Grease		x							7-50
Machine fittings - Grease		x							7-51
Hydraulic oil level - Check	x								7-52
Transmission oil level - Check	x								7-53
Engine coolant level - Check	x								7-54
Initial 100 hours									
Wheel nuts tightening - Check	x								7-55
Engine oil (Initial) - Change			x						7-56
Engine oil filter (Initial) - Replace				x					7-58
Fuel pre-filter (Initial) - Replace				x					7-59
Fuel filter (Initial) - Replace					x				7-60
Hydraulic oil filters (Initial) - Replace					x				7-61
Front and rear axle oil (Initial) - Change							x		7-62
Every 100 hours									
Machine fittings - Grease		x							7-64
Every 250 hours									
Drive shaft slip joints - Grease		x							7-68
Cab air recirculation filter - Cleaning					x				7-69
Cab air pre-filter - Cleaning					x				7-71
Cab air filter - Cleaning					x				7-73
Wheels - Tire inflating	x								7-75
Drive belts - Check	x								7-77
Every 500 hours									
Engine oil - Change			x						7-80
Engine oil filter - Replace				x					7-82
Fuel pre-filter - Replace				x					7-83
Fuel filter - Replace				x					7-84
Fuel tank sediment - Drain							x		7-85
Front and rear axle oil level - Check	x								7-86
Front and rear axle oil - Severe duty - Change			x						7-87
Roll Over Protective Structure (ROPS) - Check	x								7-89
Battery fluid level - Check	x								7-92
DEF/AdBlue® tank vent filter - Replace				x					7-93
Every 1000 hours									
Pivot points - Grease		x							7-94
Hydraulic oil filter - Replace				x					7-95
Drive belts - Replace				x					7-96
Cab air recirculation filter - Replace				x					7-99
Cab air pre-filter - Replace				x					7-100
Cab air filter - Replace				x					7-101
Engine breather filter - Replace				x					7-103
Front and rear axle oil - Change							x		7-105

## Transmission oil level - Check

Check the transmission oil level every 50 hours of operation.

### Prior operation:

Keep all unauthorized personnel clear of the area. Park the machine on level ground, in neutral with the parking brake applied, and the attachment lowered to the ground. Make sure that all residual pressure is relieved from circuits before beginning maintenance. Install the transport service link to prevent unexpected articulation movements.

Service specifications	
Type of oil	<b>CASE AKCELA NEXPLORE™ FLUID</b>
Capacity	<b>18.9 L (20.0 US qt)</b>

### Cold oil level check

Before you start the engine, check the transmission oil level in the sight gauge. If the oil level is below the arrow, add **CASE AKCELA NEXPLORE™ FLUID** to raise the oil level up to the arrow.

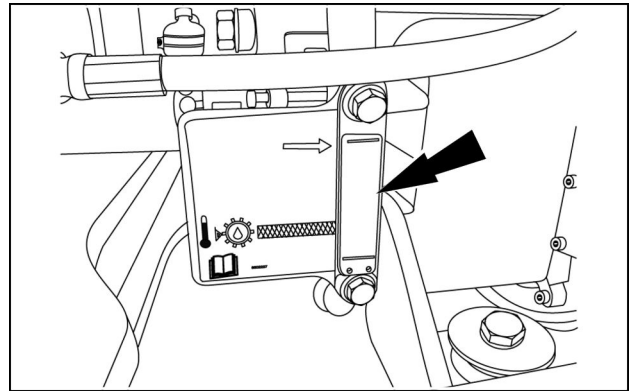

RCPH10WHL141AAH 1

### Engine running check

#### **⚠ WARNING**

**Hazard to bystanders!**

**Make sure the area surrounding the machine is clear of all persons before starting the engine.**

**Failure to comply could result in death or serious injury.**

W0090A

1. Make certain the parking brake is set. Engage the hydraulic functions lock-out to neutralize the hydraulic flow.
2. Place the transportation/service link in the service position in order to prevent unexpected articulation movements.
3. Locate the transmission oil level sight gauge on the left-hand side of the machine.
4. Ventilate properly to reduce the deadly exhaust fumes. If you have to perform this check in an enclosed area, make sure there is ventilation to replace the exhaust fumes with fresh air.
5. Check the transmission oil level at idle speed with the oil temperature of **65 – 70 °C (149.0 – 158.0 °F)**. The oil level should rise to the top of the gauge. The oil level must be between the bottom and top of the cross hatch region.
6. Add **CASE AKCELA NEXPLORE™ FLUID**, if necessary. Do not overfill.

5. Fill both axles with new **CASE AKCELA TRANSAXLE FLUID 80W-140** at the fill locations. The oil should reach the bottom of the fill plug.

**NOTE:** the oil will take some time to fill each axle. Allow time for the oil to circulate throughout the axle.

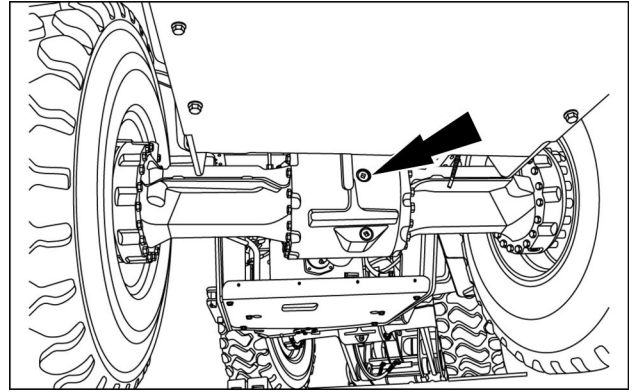

RCPH10WHL081AAH 3

## Cab air filter - Cleaning

### ⚠ WARNING

Eye injury hazard!

Wear full coverage safety glasses with side panels when using compressed air.

Failure to comply could result in death or serious injury.

W1531A

Clean the cab air filter every 250 hours.

**NOTE:** it is recommended to perform the cleaning of cab air pre-filter and filter at the same time.

1. Turn the latch (1) to open the right-hand door (2).

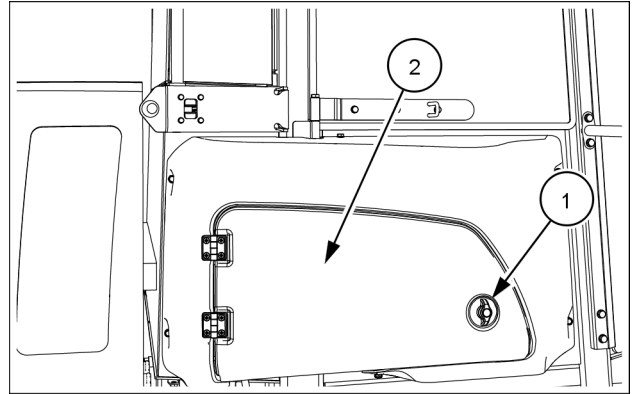

LEIL16WHL1352AA 1

2. Unhook the three clips securing the filter grid assembly.

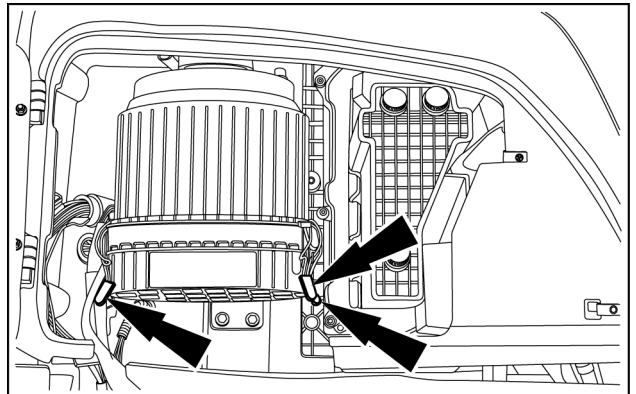

LEIL15WHL0637AA 2

3. Remove the filter grid assembly (1) from the filter housing (2).

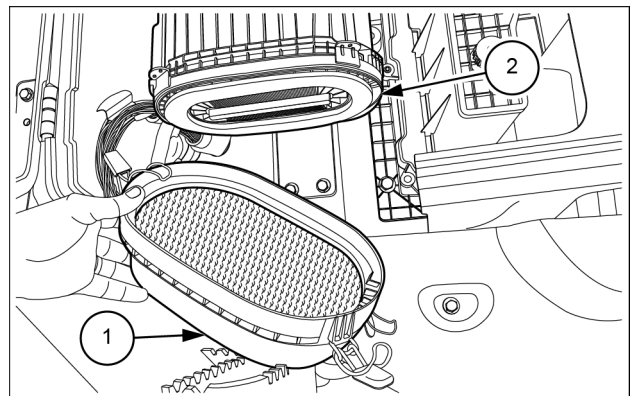

LEIL17WHL1653AB 3

## Fuel pre-filter - Replace

### **⚠ WARNING**

Fuel vapors are explosive and flammable.

Do not smoke while handling fuel. Keep fuel away from flames or sparks. Shut off engine and remove key before servicing. Always work in a well-ventilated area. Clean up spilled fuel immediately. Failure to comply could result in death or serious injury.

W0904A

Change the pre-filter every 500 hours or more often if conditions so require or if fuel quality is poor.

### **Prior operation:**

Keep all unauthorized personnel clear of the area. Park the machine on level ground, in neutral with the parking brake applied and the attachment lowered to the ground. Make sure that all residual pressure is relieved from circuits before beginning maintenance. Install the service link to prevent unexpected articulation movements.

### **Drain fuel pre-filter condensation**

1. Open the engine hood. Locate the fuel pre-filter on the right-hand side of the machine.
2. Remove the connector from the bottom of the fuel pre-filter. Open the drain valve on the fuel prefilter by turning counterclockwise two or three turns.
3. Drain the water and/or contaminants from the pre-filter into a suitable container until clean fuel flows. Do not allow fuel to spill on engine or ground.
4. Turn the pre-filter counterclockwise to remove.
5. Replace with a new pre-filter cartridge, turning clockwise until the cartridge meets the pre-filter head. Hand tighten firmly in place. Do not use a wrench to tighten.
6. Replace the connector at the bottom of the pre-filter.
7. Use the pump at the top of the pre-filter to bleed air from the fuel system. Pump until fuel flows out of the bleed screw without air bubbles.
8. Check for leaks.

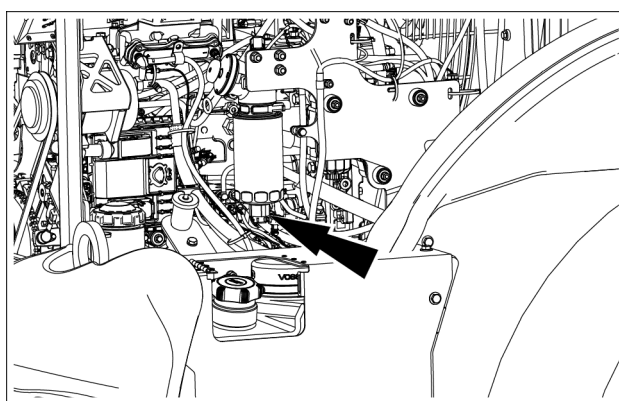

LEIL16WHL1363AA 1

## DEF/AdBlue® tank vent filter - Replace

Replace the **DEF/AdBlue®** tank vent filter every 500 hours or more frequently when operating conditions are severe.

1. Lower bucket/attachment to the ground and install the transport/service link into the lock position.

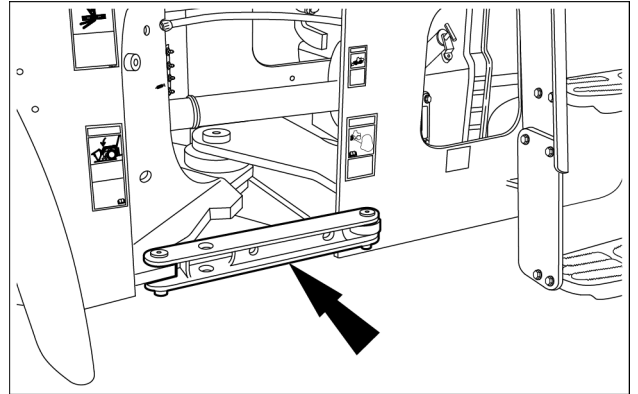

LEIL16WHL0048AB 1

2. Open the engine compartment. The **DEF/AdBlue®** tank vent filter is located on the right-hand side of the machine and is attached to the rear plate of the cooling system frame.

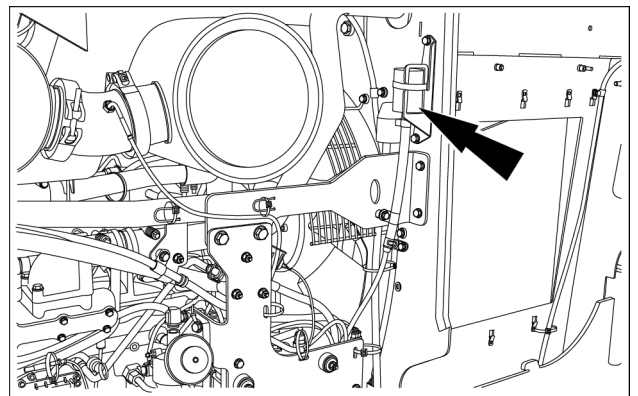

LEIL15WHL0284AA 2

3. Loosen the clamps from the breather body and remove from the hose.
4. Discard appropriately and install a new filter.

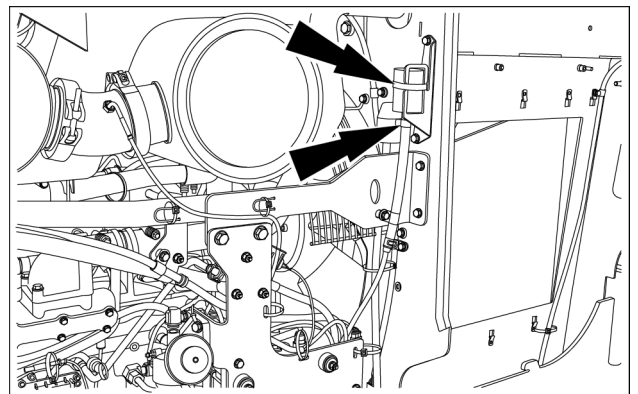

LEIL15WHL0284AA 3

## Engine breather filter - Replace

Replace the engine breather filter every 1000 hours or more frequently when operating conditions are severe.

### Prior operation:

Keep all unauthorized personnel clear of the area. Park the machine on level ground, in neutral with the parking brake applied, and the attachment lowered to the ground. Make sure that all residual pressure is relieved from circuits before beginning maintenance. Install the service link to prevent unexpected articulation movements.

1. Access the engine breather filter from the right-hand side of the machine. The engine breather filter is located in back of the fan.

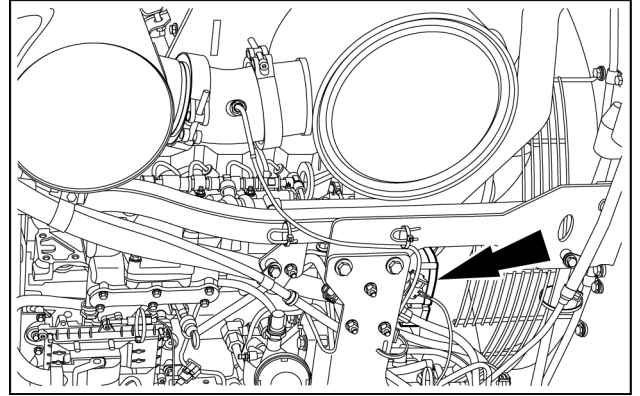

LEIL15WHL0184AB 1

2. Remove the two bolts (2) that secure the fan grill (1) to the cooling system frame.
3. Remove the fan grill (1).

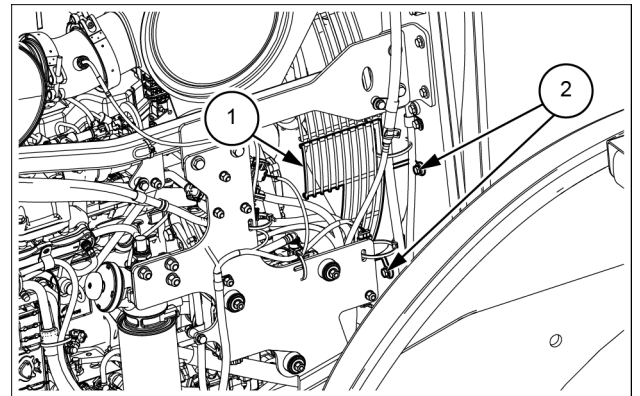

LEIL16WHL1361AB 2

4. Remove the two bolts (1). Remove the bolt (4) (with the related washer, spacer and nut) to loosen the P-clamp. Lay down the DEF/AdBLUE® vent filter (2) and the bracket (3) as an assembly to obtain sufficient access to the engine breather filter.

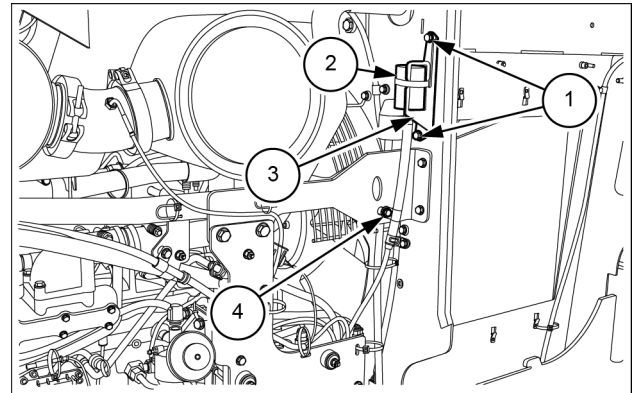

LEIL15WHL0186AB 3

7. Locate the hydraulic oil remote drain. Use a suitable container to collect the used oil. Drain the hydraulic oil completely. Install the drain plug.

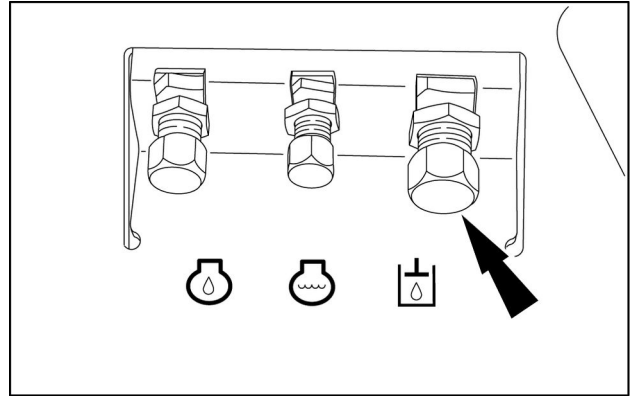

RAPH12WEL1411AA 2

8. Clean the area around the reservoir filler cap , and slowly remove the cap.
9. Fill the reservoir with new hydraulic **CASE AKCELA HYDRAULIC EXCAVATOR FLUID**.
10. Install the reservoir filler cap.
11. Start the engine and run at **1050 RPM**. Check for leakage around the filter and drain.
12. Operate the loader controls several times to remove any air in the lines.
13. Place the loader bucket/attachment on the ground and stop the engine. Check the hydraulic oil level.
14. If it is necessary to top off with more oil, remove the fill cap slowly to release pressure in the reservoir.

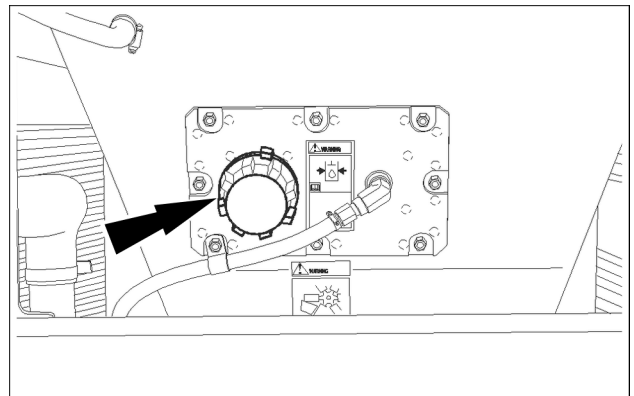

LEIL16WHL0078AB 3

- Remove the equalizing element from the center of the filter. Discard the equalizing element following local environmental and waste regulations.

**NOTICE:** contamination or damage of the sealing surface on the housing must be prevented.

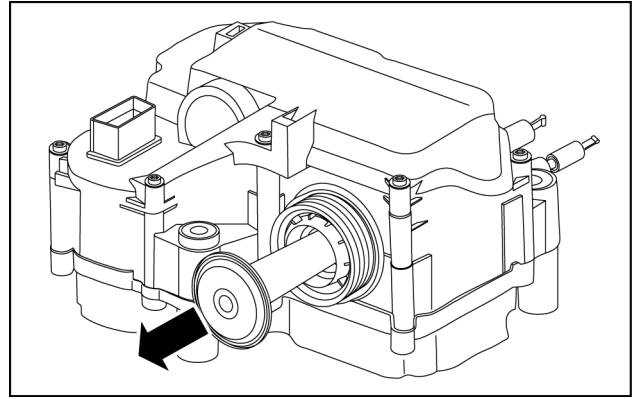

LEIL15WHL0043AB 4

- Observe the color of the filter (gray or black).

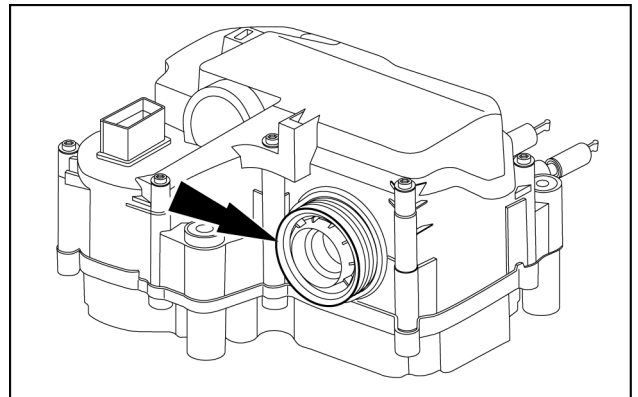

LEIL15WHL0044AB 5

- Insert the corresponding marked end of the filter removal tool, which belongs to the kit of the filter spare parts, until a click is felt or heard, indicating that the tool is completely inserted.
- Pull the filter and the filter removal tool out by hand. If necessary, insert a tool in the filter removal tool's slot for additional leverage. Discard the filter following local environmental and waste regulations.

**NOTICE:** protect the filter chamber from contamination and particles.

- Clean the supply module's thread surfaces and the internal filter housing surface with water.
- Oil the O-rings of the new filter and insert them into the supply module housing. FL Petronas Hidrobak ISO VG 10 oil is recommended.

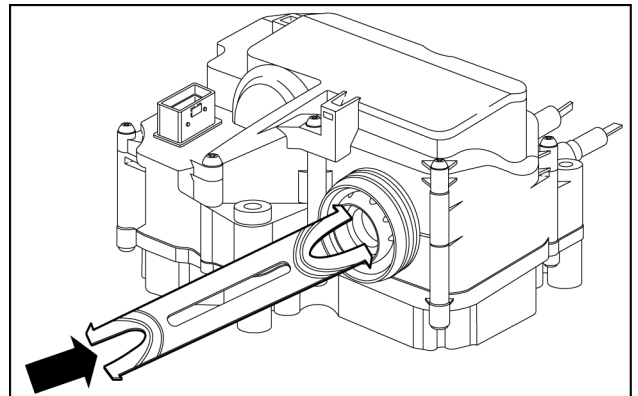

LEIL14WHL0005AB 6

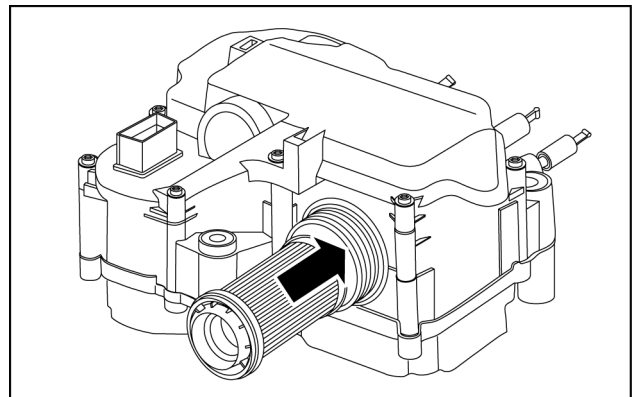

LEIL15WHL0045AB 7

4. Press and turn on the two fins (arrows) to remove the **DEF/AdBLUE®** tank filter (1) from the twist filler neck (2).  
Clean the **DEF/AdBLUE®** tank filter (1) with water to remove any debris and reinstall the **DEF/AdBLUE®** tank filter (1).

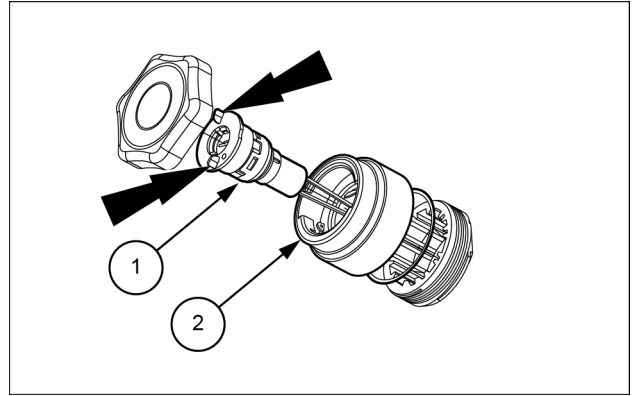

LEIL15WHL1337AB 4

5. Reinstall the O-ring (3) on the **DEF/AdBLUE®** tank neck with the radius surface facing up.  
Reinstall the filter twist filler neck (2) and the cap (1).

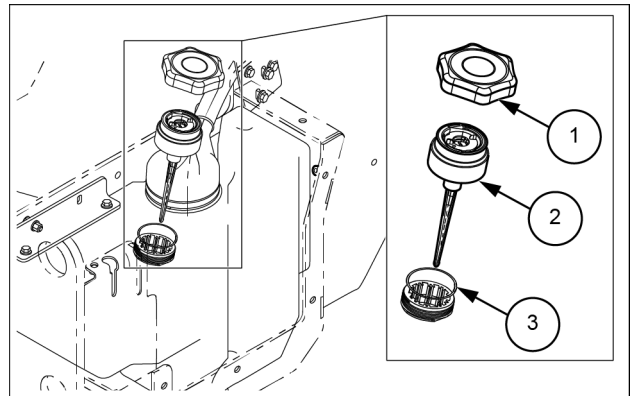

LEIL15WHL1336AB 5

### Replacing the tank filter

6. If the **DEF/AdBLUE®** tank filter has been damaged, replace the **DEF/AdBLUE®** tank filter as described in the previous steps.

**NOTE:** the urea quality sensor on the bottom of the **DEF/AdBLUE®** tank can be removed to drain fluid as necessary. When removing the urea quality sensor, it is recommended that the electrical harness should not be disconnected from the urea quality sensor. The urea quality sensor should be cleaned by flushing with deionized water before re-installation. Note that the sensor should not be submerged while cleaning so that water does not enter the vent located on the bottom of the sensor. Also note that if the harness was disconnected from the sensor, the electrical pins must be cleaned with electrical contact cleaner and dried before the harness is reconnected to the sensor.

## Windshield washer fluid level - Check

Check the windshield fluid level as required. The windshield washer reservoir is located on the right-hand side of the machine, next to the steps.

If the windshield fluid level is too low, remove the filler cap and add a windshield solution as required. Reinstall the cap.

**NOTE:** use professional detergent fluid SC35 diluted with water in relation to the temperature of use. With a 50 – 50 solution of detergent and water the liquid does not freeze until **-10 °C (14 °F)**. Below this temperature, use pure detergent.

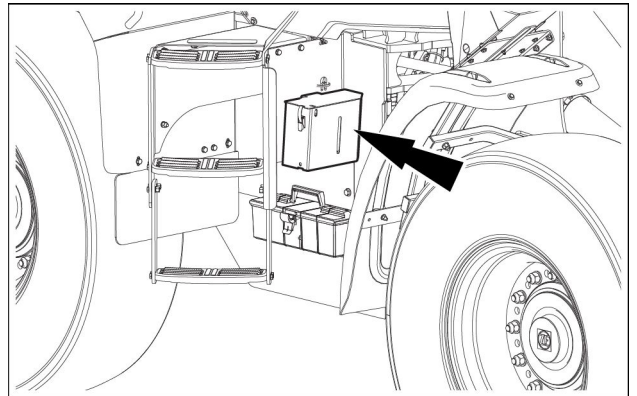

LEIL17WHL1739AB 1



9. Place a suitable container below the **DEF/AdBLUE®** supply tank. Remove the Urea Quality Sensor (UQS), allow to drain the **DEF/AdBLUE®** through the UQS hole. Reinstall the UQS.

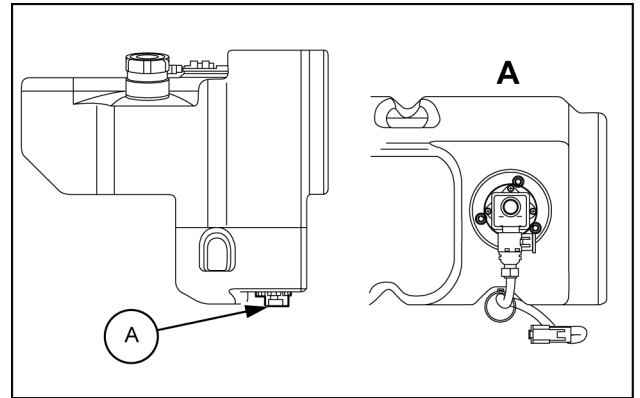

LEIL15WHL0236AB 2

10. Grease the cylinder rods.
11. Remove the batteries, clean the battery housings and make sure not to leave any traces of acid. Store the batteries safely in a cool and dry location, where the temperature will be higher than **0 °C (32.0 °F)**.
12. Paint any areas where the paint shows signs of deterioration.
13. Plug the air filter inlet and the exhaust pipe.
14. Remove the starter switch key and place a "DO NOT OPERATE" label on the right-hand control arm.
15. Lock the hoods and the cab door.

8 - SPECIFICATIONS

**521G Z-Bar Specifications - 1.9 m<sup>3</sup> (2.5 yd<sup>3</sup>) - Pin On**

	Bucket Only	Bucket with Bolt-on Edge
<b>Bucket Specifications</b>		
Capacity (heaped)	<b>1.98 m<sup>3</sup> (2.59 yd<sup>3</sup>)</b>	<b>2.10 m<sup>3</sup> (2.75 yd<sup>3</sup>)</b>
Bucket width (maximum outer)	<b>2490 mm (98.0 in)</b>	<b>2497 mm (98.3 in)</b>
<b>Dimensional Outline Specifications</b>		
A (top of cab height)	<b>3280 mm (129.1 in)</b>	<b>3279 mm (129.1 in)</b>
B (wheelbase)	<b>2750 mm (108.3 in)</b>	<b>2750 mm (108.3 in)</b>
C (ground clearance)	<b>341 mm (13.4 in)</b>	<b>341 mm (13.4 in)</b>
D (rear angle of departure)	<b>30°</b>	<b>30°</b>
Overall width with bucket guard	<b>2448 mm (96.4 in)</b>	<b>2448 mm (96.4 in)</b>
Centerline tread width	<b>2000 mm (78.7 in)</b>	<b>2000 mm (78.7 in)</b>
Turning radius (outside of tires)	<b>5002 mm (196.9 in)</b>	<b>5002 mm (196.9 in)</b>
Turning angle from center	<b>40°</b>	<b>40°</b>
Total turning angle	<b>80°</b>	<b>80°</b>
E (fully raised with spillguard)	<b>4743 mm (186.7 in)</b>	<b>4743 mm (186.7 in)</b>
F (hinge pin - fully raised)	<b>3606 mm (142.0 in)</b>	<b>3605 mm (141.9 in)</b>
G (overall - bucket level on ground)	<b>6718 mm (264.5 in)</b>	<b>6838 mm (269.2 in)</b>
H (dump - fully raised, 45° dump)	<b>2694 mm (106.1 in)</b>	<b>2612 mm (102.8 in)</b>
J (reach - fully raised, 45° dump)	<b>1059 mm (41.7 in)</b>	<b>1114 mm (43.9 in)</b>
K (reach - <b>2.13 m (7.0 ft)</b> , 45° dump)	<b>1480 mm (58.3 in)</b>	<b>1488 mm (58.6 in)</b>
L (dig depth)	<b>56 mm (2.2 in)</b>	<b>83 mm (3.3 in)</b>
<b>ISO Load Specifications</b>		
Operating Weight (without load)	<b>10950 kg (24141 lb)</b>	<b>11098 kg (24467 lb)</b>
Operating load	<b>3622 kg (7985 lb)</b>	<b>3526 kg (7773 lb)</b>
Tipping load		
Machine straight	<b>8419 kg (18561 lb)</b>	<b>8229 kg (18142 lb)</b>
<b>40° turn</b>	<b>7243 kg (15968 lb)</b>	<b>7053 kg (15549 lb)</b>

	Bucket with Teeth	Bucket with Segments
<b>Bucket Specifications</b>		
Capacity (heaped)	<b>1.98 m<sup>3</sup> (2.59 yd<sup>3</sup>)</b>	<b>2.07 m<sup>3</sup> (2.71 yd<sup>3</sup>)</b>
Bucket width (maximum outer)	<b>2540 mm (100.0 in)</b>	<b>2540 mm (100.0 in)</b>
<b>Dimensional Outline Specifications</b>		
A (top of cab height)	<b>3279 mm (129.1 in)</b>	<b>3279 mm (129.1 in)</b>
B (wheelbase)	<b>2750 mm (108.3 in)</b>	<b>2750 mm (108.3 in)</b>
C (ground clearance)	<b>341 mm (13.4 in)</b>	<b>341 mm (13.4 in)</b>
D (rear angle of departure)	<b>30°</b>	<b>30°</b>
Overall width with bucket guard	<b>2448 mm (96.4 in)</b>	<b>2448 mm (96.4 in)</b>
Centerline tread width	<b>2000 mm (78.7 in)</b>	<b>2000 mm (78.7 in)</b>
Turning radius (outside of tires)	<b>5002 mm (196.9 in)</b>	<b>5002 mm (196.9 in)</b>
Turning angle from center	<b>40°</b>	<b>40°</b>
Total turning angle	<b>80°</b>	<b>80°</b>
E (fully raised with spillguard)	<b>4743 mm (186.7 in)</b>	<b>4743 mm (186.7 in)</b>
F (hinge pin - fully raised)	<b>3606 mm (142.0 in)</b>	<b>3605 mm (141.9 in)</b>
G (overall - bucket level on ground)	<b>6937 mm (273.1 in)</b>	<b>6937 mm (273.1 in)</b>
H (dump - fully raised, 45° dump)	<b>2548 mm (100.3 in)</b>	<b>2548 mm (100.3 in)</b>
J (reach - fully raised, 45° dump)	<b>1188 mm (46.8 in)</b>	<b>1188 mm (46.8 in)</b>
K (reach - <b>2.13 m (7.0 ft)</b> , 45° dump)	<b>1523 mm (60.0 in)</b>	<b>1523 mm (60.0 in)</b>
L (dig depth)	<b>85 mm (3.3 in)</b>	<b>85 mm (3.3 in)</b>
<b>ISO Load Specifications</b>		
Operating Weight (without load)	<b>11045 kg (24350 lb)</b>	<b>11127 kg (24531 lb)</b>
Operating load	<b>3560 kg (7848 lb)</b>	<b>3507 kg (7732 lb)</b>
Tipping load		
Machine straight	<b>8297 kg (18292 lb)</b>	<b>8191 kg (18058 lb)</b>
<b>40° turn</b>	<b>7121 kg (15699 lb)</b>	<b>7015 kg (15465 lb)</b>

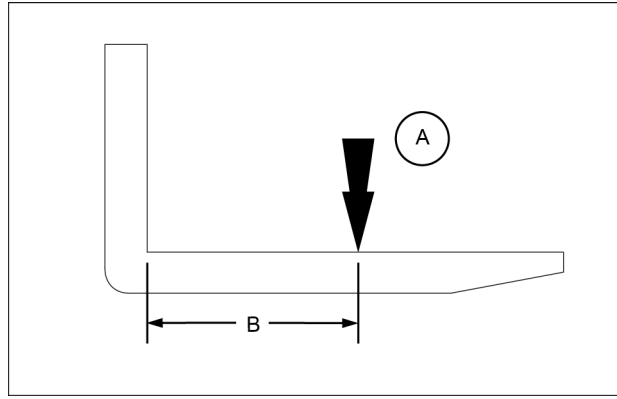

LEIL16WHL0428AB 6

**521G XR Specifications - Forks (P/N: 93203111) with Leonardi Coupler (P/N: 47447614)**

- (A) Operating load
- (B) 600 mm (23.6 in)

**NOTE:** machine configured with Heavy Duty counterweight and Michelin 17.5R25 XTLA TL tires.

Load Specifications (EN 474-3)

Operating load	
Rough terrain	<b>2572 kg (5670 lb)</b>
Firm and level ground	<b>3430 kg (7562 lb)</b>

**NOTE:** machine configured with Heavy Duty counterweight and Michelin 20.5R25 XTLA TL tires.

Load Specifications (EN 474-3)

Operating load	
Rough terrain	<b>2662 kg (5869 lb)</b>
Firm and level ground	<b>3550 kg (7826 lb)</b>

### Accessory mounting pole (Optional)

The cab can be equipped with a pole to be used for mounting additional accessories. This feature is located at the right-hand side next to the window.

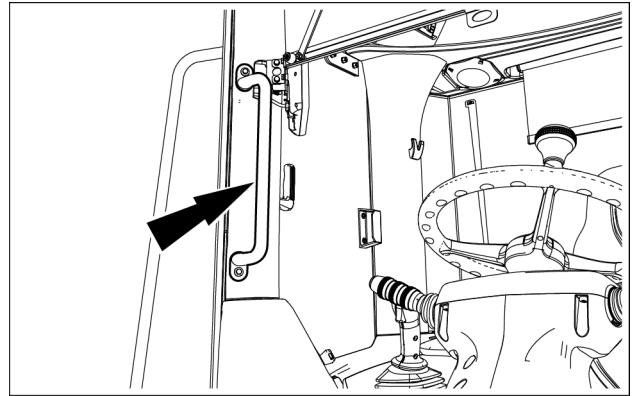

LEIL16WHL1271AB 7

### Heated mirrors (Optional)

Exterior mirrors on the machine at both right and left-hand sides are an important safety feature. They allow the operator to see around the machine when backing or driving. Heated mirrors offer an additional advantage by keeping the operator's field of vision clear of ice, frost, freezing rain, etc. when using the exterior mirrors. The heated feature eliminates scraping mirrors in inclement weather. Turn on and off the heated mirrors with a rocker switch located in the overhead console, inside the cab.

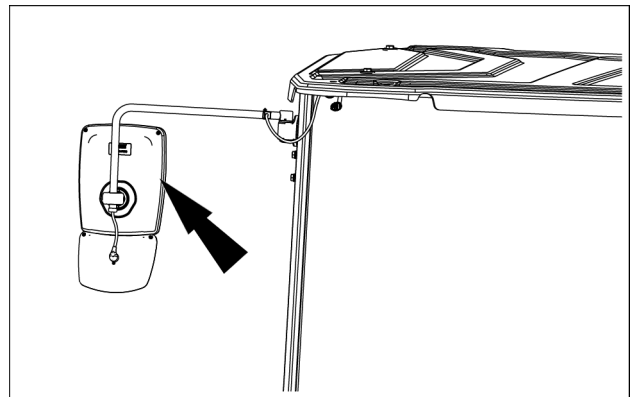

LEIL17WHL1080AB 8

### Rotating LED beacon (Optional)

The rotating beacon is an optional feature to be installed at the left-hand side of the cab roof. The beacon (1) is electrically activated with the multifunction keypad via the receptacle (2) in the front left corner of the cab roof.

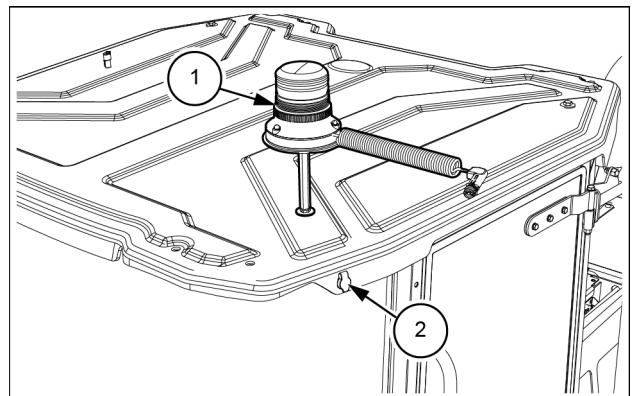

LEIL17WHL1480AB 9

CLICK HERE TO **DOWNLOAD** THE COMPLETE MANUAL

- Thank you very much for reading the preview of the manual.
- You can download the complete manual from: [www.heydownloads.com](http://www.heydownloads.com) by clicking the link below



- Please note: If there is no response to CLICKING the link, please download this PDF first and then click on it.

CLICK HERE TO **DOWNLOAD** THE COMPLETE MANUAL