

**CASE**

**OPERATOR'S MANUAL  
WHEEL LOADER  
521E  
TIER 3**

CNH AMERICA LLC  
700 STATE STREET  
RACINE, WI 53404 U.S.A.

North American English  
Part Number 87479806 EUR  
Printed in U.S.A. • Bur

87479806 EUR  
Replaces 87647789 EUR

Issued 01Mar 08

CLICK HERE TO **DOWNLOAD** THE COMPLETE MANUAL

- Thank you very much for reading the preview of the manual.
- You can download the complete manual from: [www.heydownloads.com](http://www.heydownloads.com) by clicking the link below



- Please note: If there is no response to CLICKING the link, please download this PDF first and then click on it.

CLICK HERE TO **DOWNLOAD** THE COMPLETE MANUAL

**MACHINE COMPONENTS**

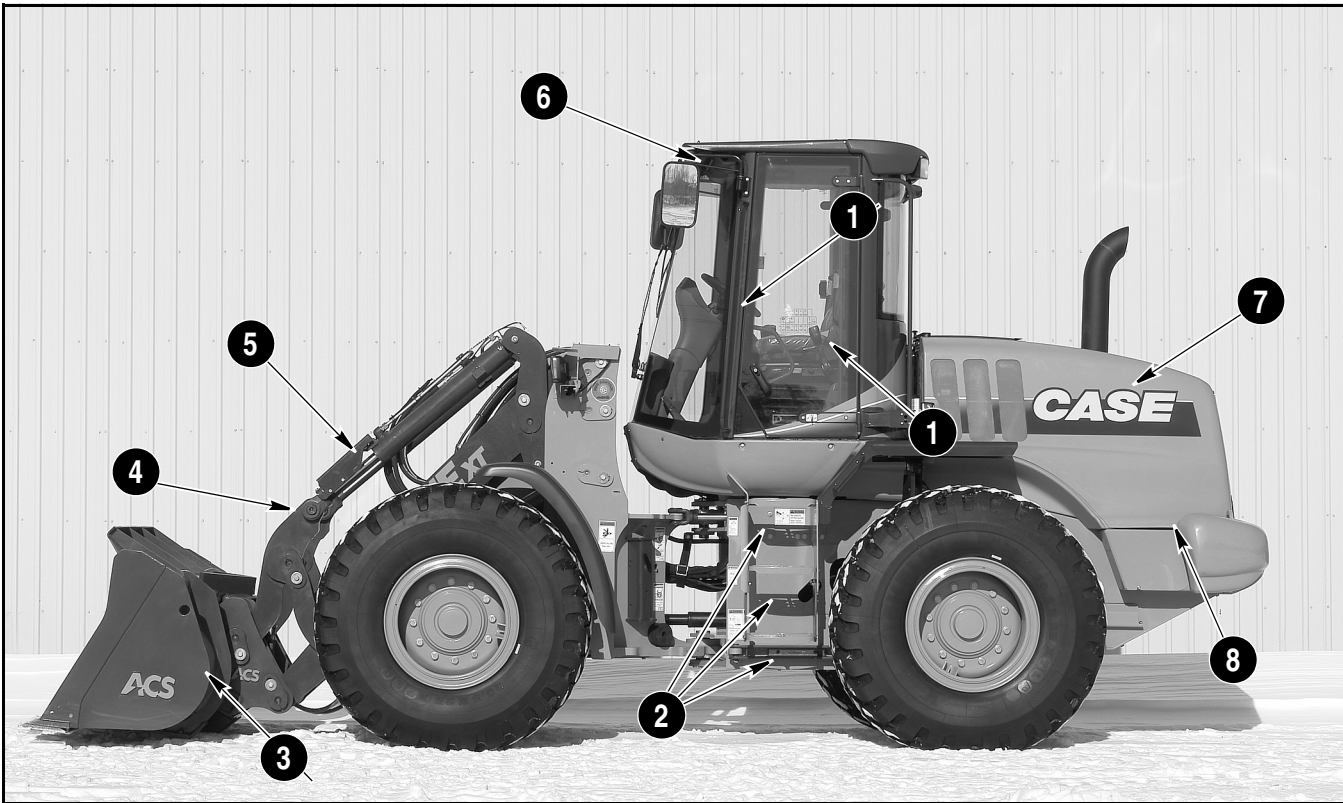

BD08A009

Figure 6

**MACHINE COMPONENTS**

- |                            |                        |
|----------------------------|------------------------|
| 1. CAB DOOR AND HAND HOLDS | 5. BUCKET CYLINDER     |
| 2. STEPS                   | 6. ROPS CAB            |
| 3. BUCKET                  | 7. ENGINE HOOD         |
| 4. BELLCRANK               | 8. LEFT BATTERY ACCESS |

**FUEL HANDLING PRECAUTIONS**

- Do not smoke or permit open flames while fueling or near fueling operations.
- Never remove the fuel cap or refuel gasoline or diesel engine powered machines with the engine running or hot. Never allow fuel to spill on hot machine components. Never allow spilled fuel to contaminate the environment.
- To avoid spilling fuel, maintain control of the fuel filler nozzle when filling the tank.
- Do not fill the fuel tank completely to the top. Allow room for expansion.
- Clean up spilled fuel immediately and dispose of contaminated material in an environmentally correct manner.
- Tighten the fuel tank cap securely. Should the fuel cap be lost, replace it only with the original manufacturer's approved cap. Use of a non-approved cap without proper venting may result in pressurization of the tank.
- Never use fuel for cleaning purposes.
- Use the correct diesel fuel grade for the operating season.

**BURN PREVENTION**

**WARNING: BATTERY ACID CAUSES SEVERE BURNS.** Batteries contain sulfuric acid. Avoid contact with skin, eyes or clothing.

Antidote: EXTERNAL - Flush with water.

Antidote: INTERNAL - Drink large quantities of water or milk.

**DO NOT** induce vomiting. Seek medical attention immediately.



**EYES** - Flush with water for 15 minutes and seek medical attention immediately.

**WARNING: BATTERIES PRODUCE EXPLOSIVE GASES.** Keep sparks, flame, cigars and cigarettes away. Ventilate when charging or using in enclosed area. Always wear eye protection when working near batteries. Wash hands after handling. **KEEP OUT OF REACH OF CHILDREN.** Failure to comply could result in serious injury or death.

M144B

- When the battery electrolyte is frozen, the battery can explode if, you try to charge the battery, or if you try to boost start and run the engine. To prevent the battery electrolyte from freezing, try to keep the battery at full charge. If you do not follow these instructions, you or others in the area can be injured.

- Hot coolant can spray out if the cooling system cap is removed. To remove the cap, let the cooling system cool, turn to the first notch, wait until the pressure is released, then remove the cooling system tank cap.

**HAZARDOUS CHEMICAL PRECAUTIONS**

- If you are exposed to or come in contact with hazardous chemicals you can be seriously injured. The fluids, lubricants, paints, adhesives, coolants, etc., used with your machine can be hazardous.
- Material Safety Data Sheets (MSDS) provide information about the chemical substances within a product, safe handling procedures, first aid measures and procedures to be taken when the product is accidentally spilled or released. This information is available from your dealer.
- Before you service your machine, check the MSDS for each fluid, lubricant, etc., used in this machine. This information indicates what the risks are and how to service the machine safely. Follow this information when servicing the machine.
- Before you service this machine and before you dispose of the old fluids and lubricants, always remember the environment. DO NOT put oil or fluids into the ground or into containers that can leak.
- Check with your local environmental or recycling center or your dealer for correct disposal information.

**TRANSPORTING PRECAUTIONS**

Know the rules, laws, and safety equipment necessary for transporting this machine on a road or highway.

**FIRE EXTINGUISHER**

It is recommended that you have a fire extinguisher on your machine. Contact your dealer for the type and location of a fire extinguisher on this machine.

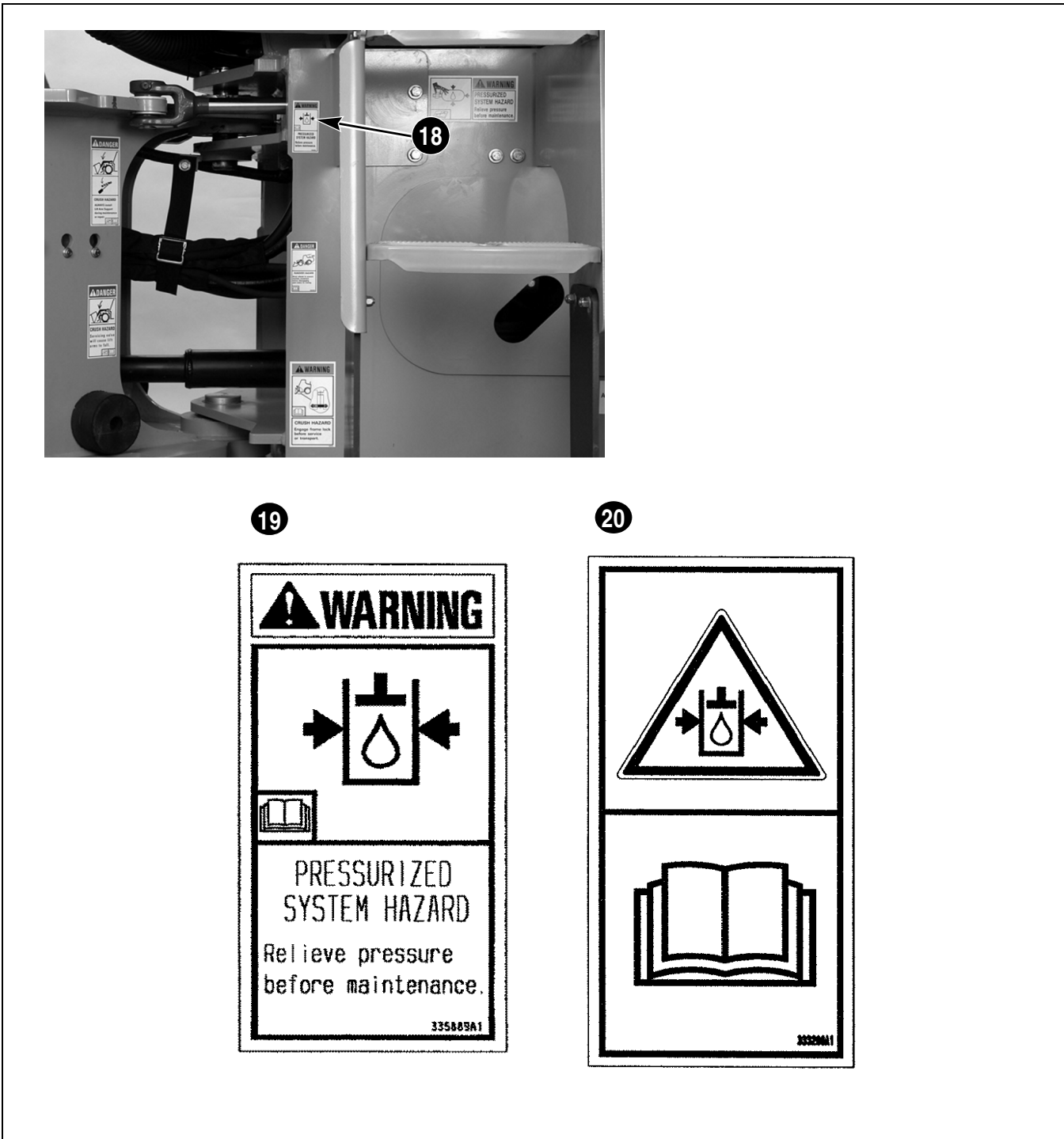

BD07N641/335889A1/333269A1

Figure 18

18. DECAL LOCATION - LEFT REAR FRAME

19. WARNING - NORTH AMERICAN DECAL NUMBER - 335889A1 - PRESSURIZED SYSTEM HAZARD

20. WARNING - ISO NUMBER - 333269A1 - PRESSURIZED SYSTEM HAZARD

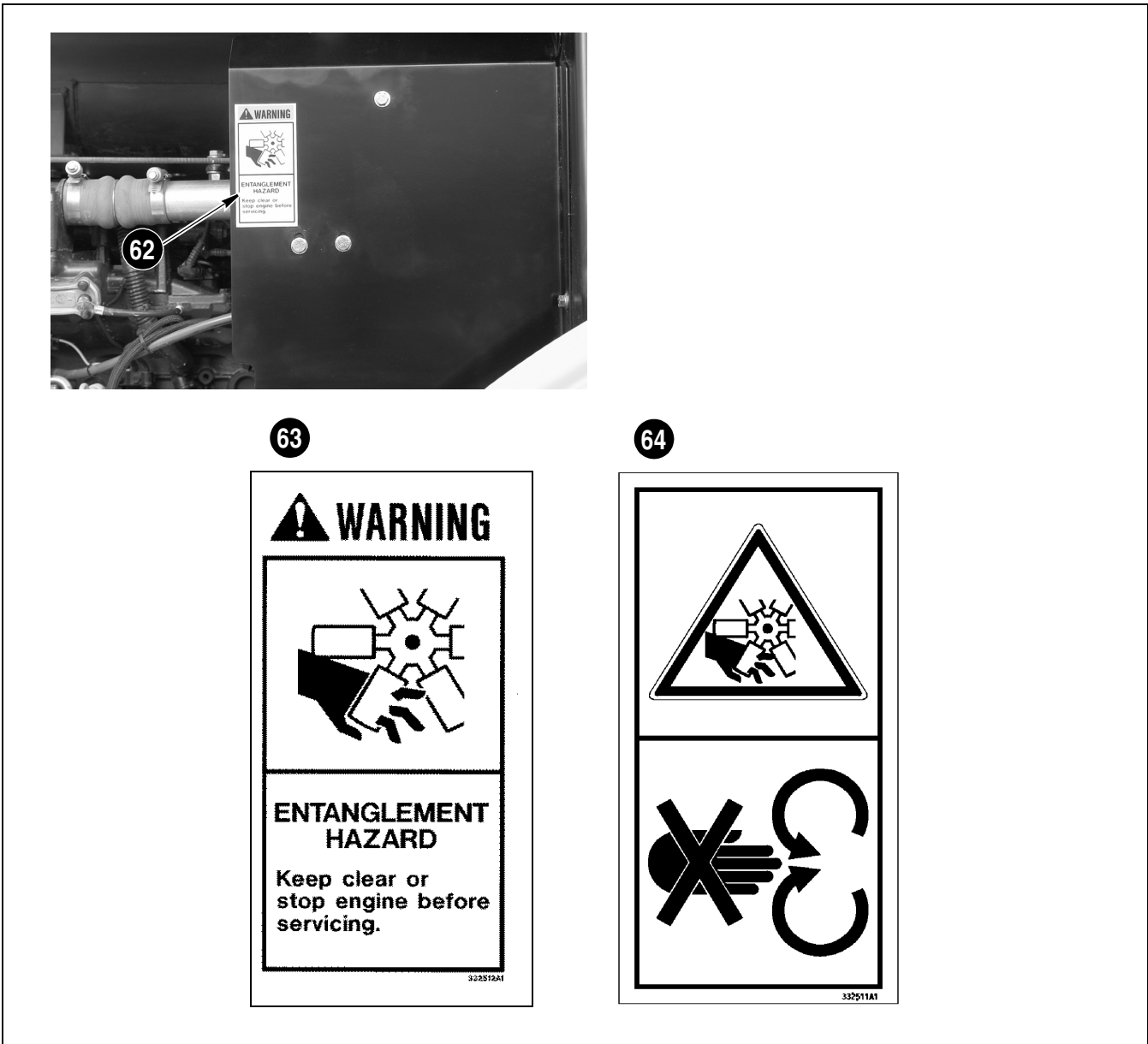

BD07N551-01/332512A1/332511A1

Figure 29

62. DECAL LOCATION - RIGHT HAND ENGINE COMPARTMENT - FAN SHIELD

63. WARNING - NORTH AMERICAN DECAL NUMBER - 332512A1 - ENTANGLEMENT HAZARD - KEEP CLEAR

64. WARNING - ISO NUMBER - 332511A1 - ENTANGLEMENT HAZARD - KEEP CLEAR



BI97D041

Figure 53

**RETRACT ARM**



BI97D032

Figure 55

**EXTEND ARM**



BI97D054

Figure 54

**FILL TOOL**



BI97D031

Figure 56

**EMPTY TOOL**

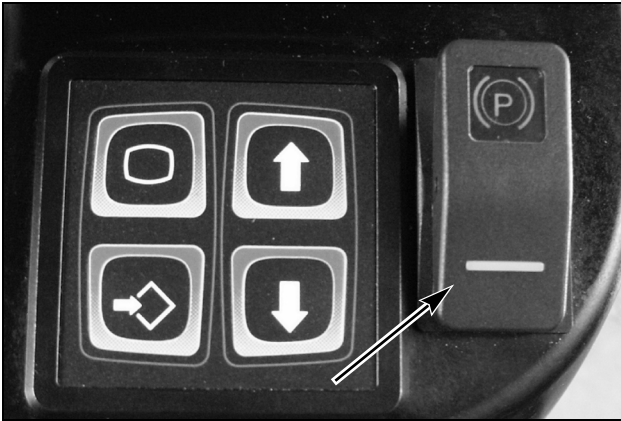
**PARKING BRAKE**

BD06F099

Figure 28

**PARKING BRAKE SWITCH**

Make sure the machine has come to a complete stop before applying the parking brake.

The parking brake button engages the parking brake on the transmission output shaft.

**IMPORTANT:** *The parking brake is a spring applied, hydraulic released brake which is applied to the drive shaft. It will effectively hold the machine in place when used correctly.*

**ENGAGING THE PARKING BRAKE**

To engage the parking brake, move the gearshift lever to neutral **N**, stop the machine and engage the brake by pushing down on the top of the switch. The parking brake will automatically engage when the machine is shut off.

**IMPORTANT:** *A failure in the operating procedure or a failure in the electrical or hydraulic function can result in abrupt engagement of the parking brake. Always wear your seat belt.*

**PARKING BRAKE RELEASE**

**NOTE:** *The service brake must be at operating pressure before the parking brake can be released to move the machine. The brake pressure indicator lamp must not be illuminated when disengaging the parking brake. Attempting to move the machine prior to the service brake pressures being sufficient causing low operating pressure can result in premature parking brake pad wear.*

**Using transmission Forward-Neutral-Reverse (FNR) control on the left side of steering column**

All the following steps are required:

1. Service brake pressure must be at operating pressure.
2. Transmission control lever must be in neutral.
3. Push down on the bottom of the parking brake switch to release the parking brake switch.

**NOTE:** *If the parking brake was NOT set when the machine was turned off, the parking brake switch must be cycled at step 3.*

4. Place the transmission control lever in either FORWARD or REVERSE to move the machine.



BD06H025

Figure 29

**Using transmission Forward-Neutral-Reverse (FNR) control on the hydraulic controller lever**

All the following steps are required:

1. Service brake pressure must be at operating pressure.
2. Left side FNR of transmission control lever must be in Neutral.
3. Right side FNR switch must be in Neutral.
4. Machine speed must be zero.
5. Engine must be running.

**INSTRUMENT PANEL INDICATORS**



BD06F096

Figure 47

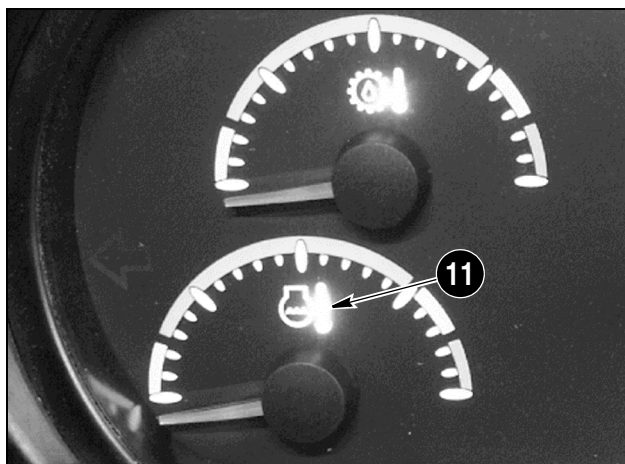

BD06F096A

Figure 48

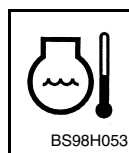

**11. ENGINE COOLANT**

**TEMPERATURE GAUGE:**

The engine coolant temperature gauge indicates the coolant temperature of the engine. Normal operating temperature is in the green zone. When the engine coolant temperature increases the gauge will move into the yellow zone, and the warning alarm sounds for three seconds. The caution master indicator turns yellow. When the temperature continues to increase the gauge moves into the red zone and the warning alarm sounds continuously. The stop master indicator turns red. **DO NOT** operate the machine when the temperature is in the red zone.

ENGINE COOLANT TEMPERATURE GAUGE				
Gauge Indication	Condition	Master Indicator	Gauge Status	Alarm Status
68° F and below (20° C and below)	Coolant temperature is very low	Caution (Yellow)	Flashes	3 Seconds
68° to 221° F (20° to 105° C)	Coolant temperature is normal			
221° to 230° F (105° to 110° C)	Coolant temperature is high	Caution (Yellow)	Flashes	3 Seconds
230° F and above (110° C and above) (See the note below.)	Coolant temperature is very high	Stop (Red)	Flashes	Continuous

**NOTE:** Do not operate the machine if the indicator turns red and the alarm sounds continuously. Stop the machine and correct the problem.

**HARDWARE/SOFTWARE SCREENS**

The hardware and software screens cannot be changed by the operator.



BD106F193

Figure 70

The hardware selection will display the part number, serial number, ID number and version of the hardware cluster. The software selection will display the part number, serial number, ID number and version of the software cluster. Press the escape key to exit from this field or use the up arrow key to scroll backwards for another selection from the select sub-menu.

SIDE CONSOLE

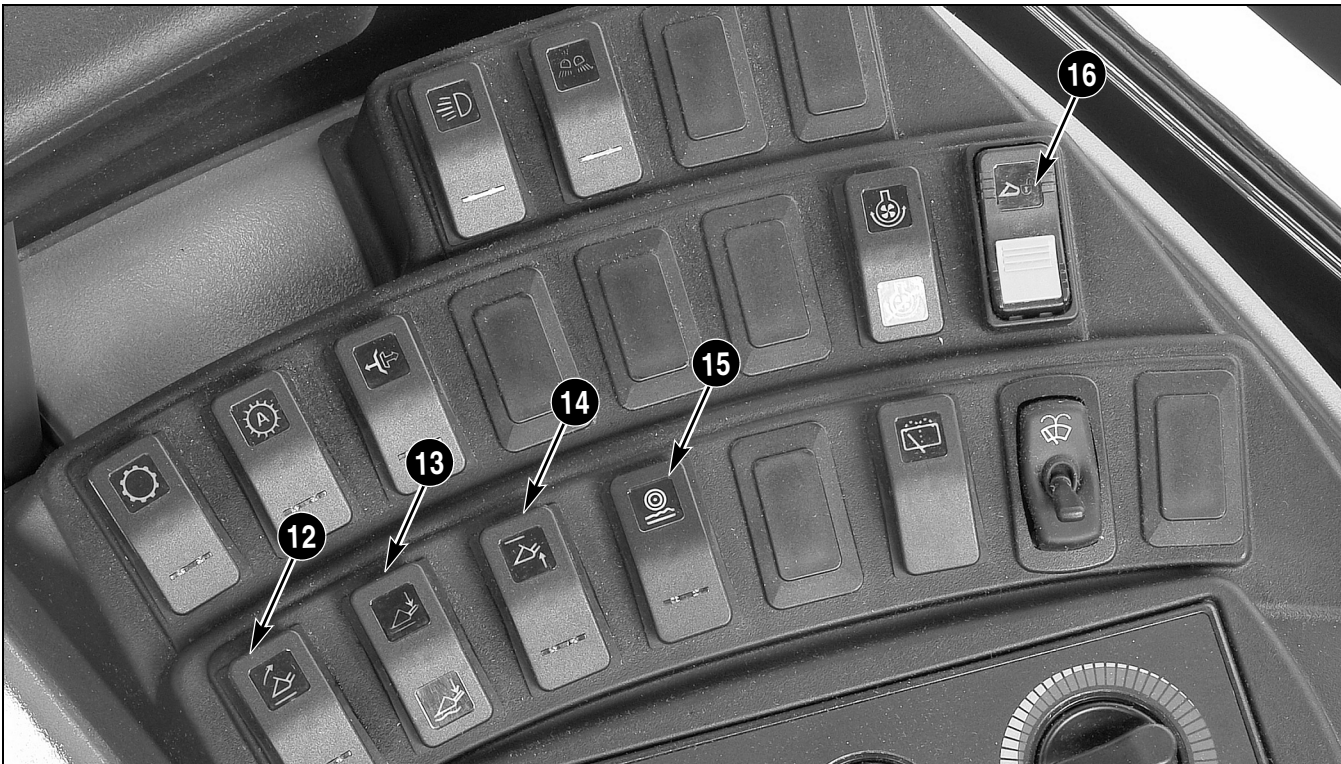

BD08A001

Figure 91



**12. RETURN TO DIG:**

Push on the top of the function switch for the ON position. This will allow the bucket to return to level with the ground for digging.



**13. RETURN-TO-TRAVEL, DETENT SWITCH:**

The Return-To-Travel switch is used to automatically return the loader bucket to the travel position after you have dumped the loader bucket. Push down on the top of the Return-To-Travel switch to engage the return to travel detent. Push the bottom of the switch for the Float Detent position.

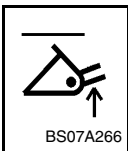

**14. HEIGHT CONTROL:**

Push on the top of the function switch for the ON position. This will allow the bucket to be raised to set height position when activated.



**15. RIDE CONTROL SWITCH (If Equipped):**

This is a 3-position switch. Push on the top of the switch for the manual ON position. Ride control can be left on at all times, whether loading or roading. The center position is the automatic and most commonly used position. In the automatic position, ride control will automatically activate when ground speed is above 5 km per hour (3.1 mph) and automatically shut off when ground speed is below 5 km per hour (3.1 mph). The indicator light on the switch will illuminate when ride control is activated. To turn ride control off, push on the bottom of the function switch for the OFF position.



**16. COUPLER PIN ENGAGE SWITCH (If Equipped):**

Slide the locking plate toward the center of the switch, push down on the top of the switch to retract the pins for the attachment. The switch lamp will illuminate when the pins are retracted. The switch will lock in the pin extended position after the bottom of the switch has been pressed and the pins are extended.

**STOPPING THE ENGINE AND PARKING THE MACHINE AFTER OPERATIONS**

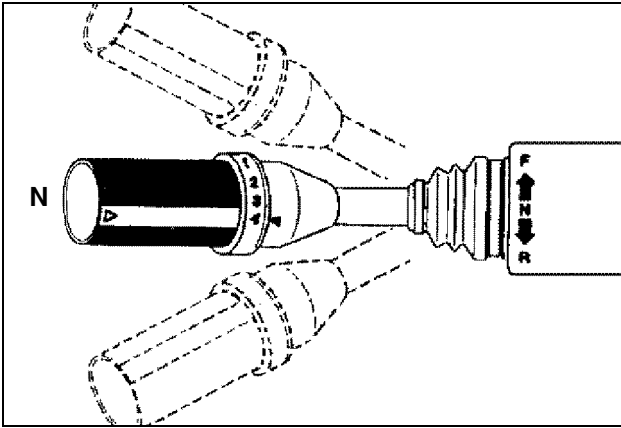

BS03K026

Figure 7

1. Stop the machine on hard, level ground and place the gearshift selector in NEUTRAL.

**IMPORTANT:** *If you must temporarily park the machine on a hillside, put the front of the machine toward the bottom of the hill. Park the machine behind an object that will not move.*

2. Lower the attachment to the ground.

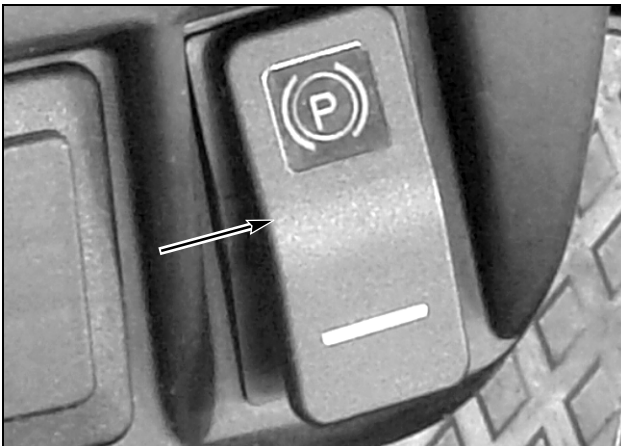

BD06H127

Figure 8

3. Shift the transmission direction control to NEUTRAL and apply the parking brake.
4. Run the engine at idle speed for three to five minutes to decrease the temperature of the engine and turbocharger.
5. Turn the key switch to the OFF position and remove the key.

**NOTE:** *Always turn the engine off at low idle to prevent damage to the turbocharger, if equipped.*



BD06F271

Figure 9

6. Slowly move the equipment control levers forward to rest the equipment on the ground.
7. Slowly move the equipment levers through all rotations to insure that residual pressures in the hydraulic system are released.
8. Turn the master disconnect switch to the OFF position. Close and lock the compartment.



**WARNING:** *Jumping on or off the machine can cause an injury. Always face the machine, use the hand holds and steps, and get on or off the machine carefully. Failure to comply could result in serious injury or death.*

CLICK HERE TO **DOWNLOAD** THE COMPLETE MANUAL

- Thank you very much for reading the preview of the manual.
- You can download the complete manual from: [www.heydownloads.com](http://www.heydownloads.com) by clicking the link below



- Please note: If there is no response to CLICKING the link, please download this PDF first and then click on it.

CLICK HERE TO **DOWNLOAD** THE COMPLETE MANUAL

**RETURN-TO-DIG**

The Return-To-Dig function is used to automatically return the loader bucket to the dig position after you have dumped the loader bucket. To enable the Return-To-Dig function press the top of the switch.



BD06F004 Figure 33

- 1. FLOAT
- 2. ROLLBACK DETENT

**RETURN-TO-TRAVEL FUNCTION**

The Return-To-Travel function is used to automatically stop the loader bucket at the carry height selected. To enable the Return-To-Travel function, press the top of the return to Travel/Float switch.



BD06F004 Figure 35

- 1. ROLLBACK DETENT
- 2. FLOAT

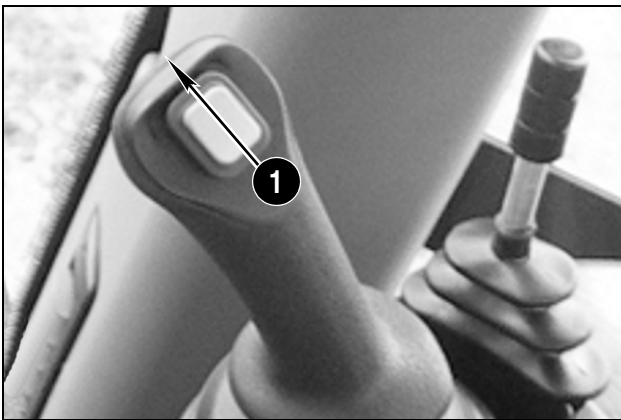

BD06F271 Figure 34

- 1. FLOAT AND ROLLBACK DETENT

To actuate, move the control lever(s) into the FLOAT and ROLLBACK detents. The bucket control lever will automatically return to the HOLD position and the loader arm will remain in float when the loader reaches the Return-To-Dig position. See Loader Adjustments in this manual for Return-To-Dig Adjustments.



BD06F271 Figure 36

- 1. FLOAT AND ROLLBACK DETENT

To actuate, move the control lever(s) into the FLOAT and ROLLBACK detents. The control lever(s) will automatically return to the HOLD position when the loader reaches the Return-To-Travel position.

## OPERATING IN COLD CLIMATE CONDITIONS

Cold weather conditions require special operating procedures. During these conditions your machine will require special start up, warm up and maintenance procedures for the best performance. Proper cold weather maintenance will extend the service life of your machine.

### BATTERIES

Clean the batteries and make sure they are at full charge. In cold conditions it is important to run the machine long enough to return the charge lost by starting. In most cold conditions this is about ten minutes, but in extreme cold it can be 30 minutes.

**NOTE:** *A fully charged battery at -17° C (0° F) has only 40% of the normal starting power. At -29° C (-20° F) the battery has only 18%.*

Inspect the battery cables and terminals. Clean the terminals and apply electrical terminal sealers to prevent corrosion. See your dealer.

If water is added to the batteries and the temperature is below 0° C (32° F), charge the batteries or run the engine for approximately 2 hours. This will prevent battery freezing.

### LUBRICANTS

Follow the recommended oil and filter service for the engine and hydraulic system as shown in this manual. Use the correct viscosity oil in each component for the ambient temperatures the machine is operating in. For extreme cold conditions, contact your dealer for alternative lubricants for the hydraulic and transmission systems.

### FUEL

Check with your fuel supplier for the correct cold weather fuel. Engine power will be reduced if wax particles are in the fuel filters. Some cold weather fuel blends result in lower engine power.

Check for water in the fuel system. Cold temperatures can cause condensation to form in the fuel tank. Check and drain the fuel filter and fuel tank for water as required.

### COOLING SYSTEM

Check the coolant mixture before operating in cold temperatures. A mixture of 50% ethylene glycol and 50% water must be used. This mixture is used if the lowest ambient temperature is -37° C (-34° F). If the ambient temperature is lower, adjust the mixture. It is recommended that ethylene glycol and water be used in the machine all year long. See Engine Cooling System in this manual.

### COLD TEMPERATURE STARTING AIDS

This machine may be equipped with an engine grid heater. Turn the key switch to **ON** and wait for the engine grid heater indicator lamp to go out. The indicator light may come on again during cranking and shortly after the engine starts for post heating of the air. This allows for smooth running conditions during cold weather warm up.



**WARNING:** *Do not use ether or other starting products with this machine. Failure to comply could result in serious injury or death.*

### MACHINE WARM UP

Once the engine has started, run the engine at about half throttle (1100 to 1300 rpm) for a minimum of four minutes under no load. This will help stabilize the engine.

After engine warm up, turn the pilot control switch (located on the console) to the on position. Place the lift arm into float and the bucket into roll back to load the engine in order to heat the hydraulic oil. Hold for approximately two minutes. This will yield approximately 20° C (68° F). Apply and hold the foot brake, cycle the lift arm and bucket. Repeat the float/roll back heating procedure again for approximately two minutes. Raise the lift arms enough to steer the unit full left and right to warm the oil in the steering cylinders. In extreme cold conditions, hold the float/roll back condition for five minutes maximum.



**WARNING:** *Make sure there is clearance around the machine before steering the machine left and right. Keep all non-authorized personnel clear of the area. Failure to comply could result in serious injury or death.*

Even with the correct oil in the hydraulic/brake system the first few times the brakes are actuated there may be some delay before the brakes are applied. The operator must actuate the brake pedal a minimum of 8 to 10 times before the machine is moved to obtain proper heating. Actuating and releasing the brakes should occur in a cycle of 3 seconds full on and 3 seconds off to obtain exchange of the brake oil.

**TRANSMISSION OIL VISCOSITY / TEMPERATURE RANGES**

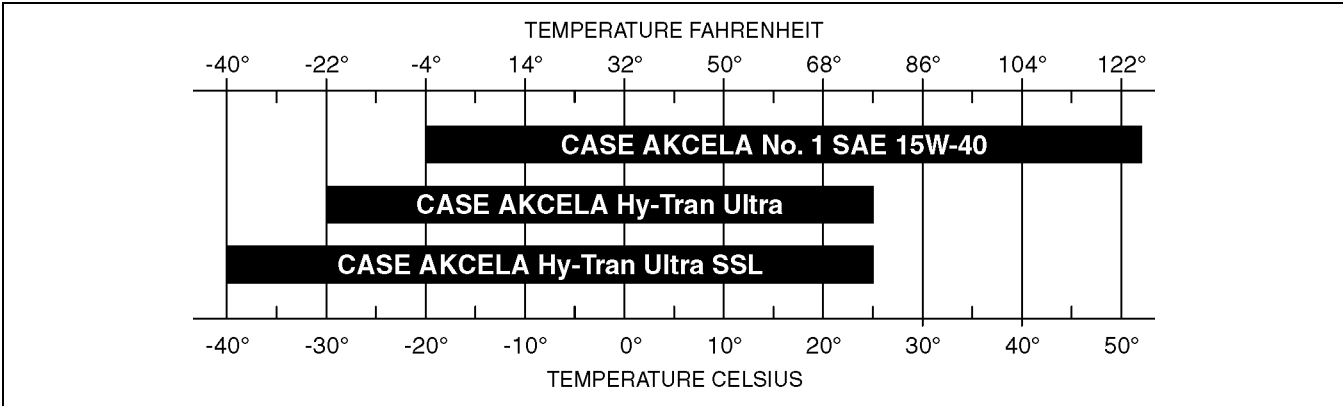

BC04F193

Figure 9

**HYDRAULIC/BRAKE SYSTEM - TEMPERATURE RANGE**

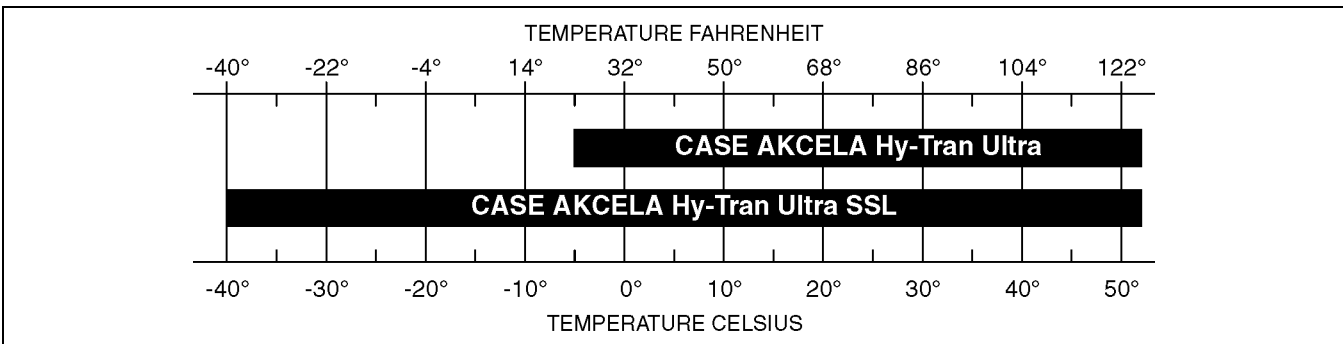

BC04F192

Figure 10

**50 HOUR MAINTENANCE**

**TRANSMISSION OIL LEVEL**

**Service Specifications**

Total system capacity . . . . . 27.5 qt. (26.0 L)

Refill capacity with filter change . . . . 20 qt. (18.90 L)

Check the transmission oil level every 50 hours of operation. Keep all non-authorized personnel clear of the area. Park the machine on level ground, in neutral with the parking brake applied and the attachment lowered to the ground. The transmission oil level sight gauge is on the left side of the machine.

**Cold Oil Level Check**

Before you start the engine, check the transmission oil level in the sight gauge. If the oil level is below the arrow, add oil to raise the oil level up to the arrow.

**Engine Running Check**

**WARNING:** This check must be performed with the engine running! Comply with the following:

1. Make sure the gear selector is in neutral and the parking brake is set.
2. Make sure the bucket or equipment is on the ground and the pilot lock out is engaged to neutralize hydraulic flow.
3. The transport/service link must be in place to prevent accidental articulation.
4. If this check must be performed in an enclosed area be sure to ventilate properly to reduce the deadly exhaust fumes.
5. Failure to comply may result in death or injury.



BS00M474 Figure 27

Check the transmission oil level at idle speed with the oil temperature of 149° to 158°F (65° to 70°C).

When oil temperature reaches the above temperatures, oil level will rise to the top of the gauge. Oil level should be between the bottom and top of the cross hatch region. Add oil, if necessary. Do not overfill.

**ENGINE COOLANT RESERVOIR**

**Service Specifications**

System capacity . . . . . 23.2 qt. (22.0 L)

Check the coolant reservoir level every 50 hours of operation. Perform this check when the coolant is cold and the engine is stopped. Do not remove the radiator cap during this check. The coolant level must be between the full and add marks on the reservoir. Add coolant as required to raise the coolant level to the full mark.

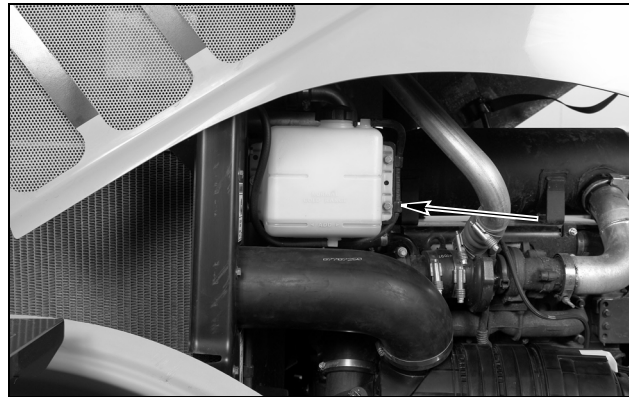

BD07N640-01 Figure 28

Raise the engine compartment access hood and check the indicator on the side of the coolant bottle.

**NOTE:** In the event that the system needs topping off make sure to use the proper ratio of water and antifreeze/coolant. Do not overfill.

**WARNING:** Hot coolant can spray out if the radiator cap is removed. To remove the radiator cap:

Let the system cool, turn to first notch, then wait until all pressure is released.



Scalding can result from fast removal of radiator cap. Check and service engine cooling system according to maintenance instructions. Failure to comply may result in death or injury.

500 HOUR MAINTENANCE

CHANGE ENGINE OIL AND FILTER

Service Specifications

Type of oil . . . . . Case Akcela (SAE 15W-40)

Capacity (with filter change) . . . . . 12.5 qt. (11.8 L)

The engine oil and filter should be changed every 500 hours or more frequently when the engine operating conditions are severe.

**NOTE:** *When changing engine oil, the oil flow rate can be improved if the oil fill cap or dipstick is removed from the engine while draining.*

1. Keep all non-authorized personnel clear of the area. Park the machine on level ground, in neutral with the parking brake applied.
2. Lower bucket/attachment to the ground and install the transport/service link into the lock position.



BD07N638-01

Figure 51

3. Remove the protective guard from the drain plug area by removing the two bolts securing it to the machine.

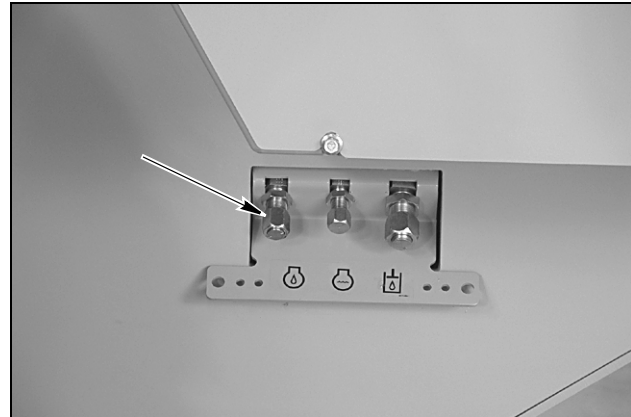

BD06F008

Figure 52

REMOTE ENGINE OIL DRAIN

4. Use a suitable container to capture the used oil, and remove the remote oil drain plug. Drain the engine oil completely.

**2000 HOUR MAINTENANCE**

**CHANGE HYDRAULIC OIL AND FILTER**

**Service Specifications**

Total system capacity . . . . . 30.0 gal. (113.6 L)

Type . . . . . Case Akcela Hy-Tran Ultra

Change the hydraulic oil and filter every 2000 hours of operation. Change oil more frequently when operating conditions are severe.

1. Keep all non-authorized personnel clear of the area. Park the machine on level ground, in neutral with the parking brake applied. Stop the engine.
2. Lower bucket/attachment to the ground and install the transport/service link into the lock position.
3. Make sure the accumulators are completely discharged by pushing down on the brake pedal a minimum of 30 times.
4. Release pressure in ride control accumulators, if equipped.
5. With the ignition key in the ON position, cycle the bucket/attachment control levers repeatedly through their complete range of motion for at least 30 seconds.
6. Move the hydraulic controller to the float position and turn the key off.



BD07N638-01

Figure 73

7. Remove the protective guard from the drain plug area by removing the two bolts securing it to the machine.

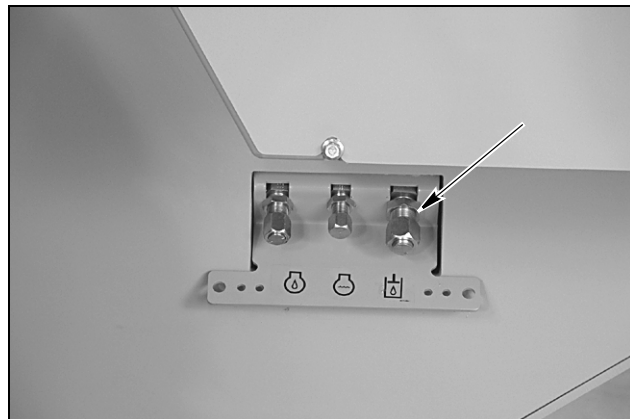

BD07A034

Figure 74

8. Open the hydraulic reservoir remote drain, and drain the oil into a suitable container.
9. Clean the area around the filler cap, and slowly remove the cap.

**250 HOUR MAINTENANCE**

**TIRE PRESSURE**

Check tire pressure when the hourmeter registers 250 hours or more frequently when operating conditions warrant.

**WARNING:** Exploding tires and / or rim parts can cause injury or death. Keep yourself and others out of the **DANGER AREA**. Stand on the tread side of the tire. Always use the correct air pressure and follow the instructions in this manual for adding air or servicing the tires. Failure to comply could result in serious injury or death.

**WARNING:** Explosive separation of the tire and / or rim parts can cause injury or death. When tire service is necessary, have a qualified tire technician service the tire.

**Service Specifications**

Normal Work Tire Inflations:

Tire Type	Front Pressure	Rear Pressure
17.5 X 25 L2 Bias	50 psi (3.4 bar)	40 psi (2.8 bar)
17.5 X 25 L3 Bias	50 psi (3.4 bar)	40 psi (2.8 bar)
17.5 R 25 L2 Radial	50 psi (3.4 bar)	40 psi (2.8 bar)
17.5 R 25 L3 Radial	50 psi (3.4 bar)	40 psi (2.8 bar)
20.5 X 25 L2 Bias	50 psi (3.4 bar)	40 psi (2.8 bar)
20.5 R 25 L2 Radial	50 psi (3.4 bar)	40 psi (2.8 bar)
20.5 X 25 L3 Bias	50 psi (3.4 bar)	40 psi (2.8 bar)
20.5 R 25 L3 Radial	50 psi (3.4 bar)	40 psi (2.8 bar)

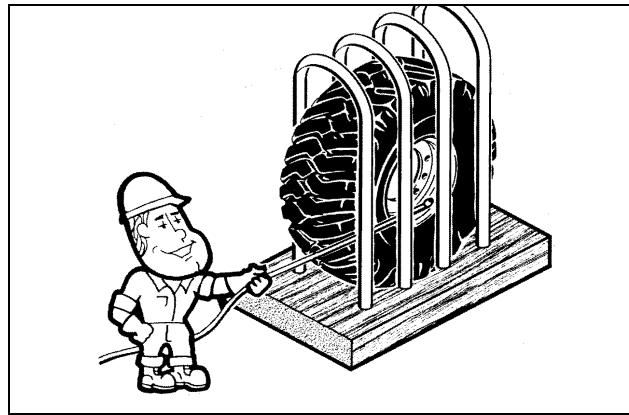

B790490R

Figure 6

**To add air to a tire:**

This procedure is only for adding air to the tire. If the tire has lost most or all of the air, do the following:

1. Keep all non-authorized personnel clear of the area.
2. Before you add air, have the wheel correctly installed on the machine or put the wheel in a restraining device (tire inflation cage).



BD03A024

Figure 7

3. Use an air hose with a remote shutoff valve and a self-locking air chuck.
4. Stand **BEHIND** the tread of the tire and make sure **ALL** personnel are away from the side of the tire before you start.
5. Inflate the tire to the recommended air pressure. **DO NOT** inflate the tire more than the recommended pressure.

## CALIBRATING THE GEAR BOX

Calibrate the gear box when the hourmeter registers 250 hours for a new machine during the initial run-in period. The gear box calibration should be performed at every 1000 hours thereafter.

After running the machine to warm the oil temperature:

1. Keep all non-authorized personnel clear of the area. Park the machine on a firm, level surface.
2. Place the transmission control lever in NEUTRAL.
3. Set the parking brake.
4. With the engine running at idle, enter the service screen menu and scroll to Config screen. Press the confirm key.



BD06F202

Figure 18

Use down arrow button to scroll to Calib G/B. Highlight Calib. G/B, and press the confirm key. Always follow the prompts on the screen. Should an error occur, use the escape key to start over again.

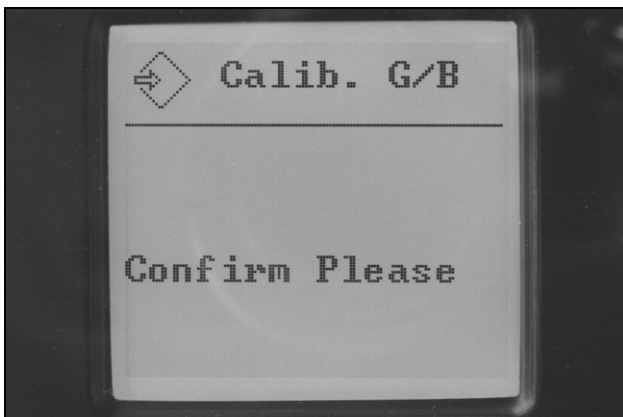

BD06F195

Figure 19

The screen will show a confirm prompt. If you doubt your ability to perform this operation, press the escape key and call your dealer.

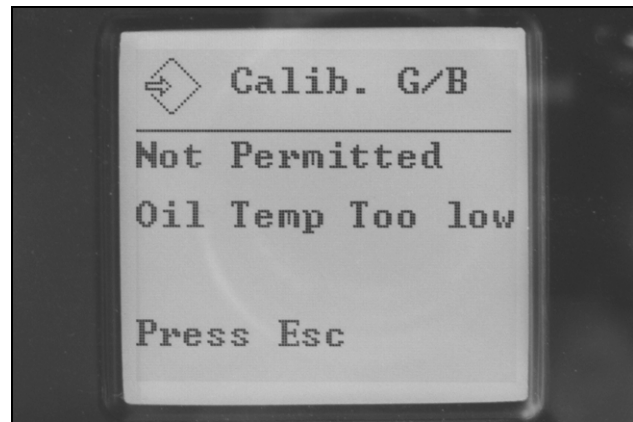

BD06F196

Figure 20

If machine conditions are incorrect, an error message will appear. The calibration procedure will not complete. Follow the prompts to aid in correcting any machine conditions.

The screen may display the following prompts to guide the user to correct machine conditions:

- Not in neutral
- Parking Brake OFF
- Machine moving
- Oil temp too low
- Oil temp too high
- Engine RPM low
- Engine RPM high

If conditions are correct, the user will see six calibration screens displayed. They will appear in the following order:

- Adjust K1
- Adjust K2
- Adjust K3
- Adjust K4
- Adjust KV
- Adjust KR

Once the calibration process is complete, the user will be prompted to turn the engine Off and restart the machine.

If the process is **not** completed, the screen will prompt the user to escape.

**NOTES**

**AUXILIARY POWER OUTLET (IF EQUIPPED)**

The Auxiliary Power Outlet socket (12 volt) can be used for the connection of a lighting device to help with service and maintenance procedures. There are two auxiliary power outlets, one in the right corner of the operator's compartment, and one in the left corner of the operator's compartment.



BD07A203

Figure 17

**LIFT CAPACITY 521E XR LIFT ARM****Lift Capacity 521E XR**

	<b>2.1 yd<sup>3</sup> (1.6 m<sup>3</sup>) Bucket w/Bolt on Edge</b>	<b>2.1 yd<sup>3</sup> (1.6 m<sup>3</sup>) Bucket w/Teeth</b>
Full Height	11527 lb (5228 kg)	11424 lb (5182 kg)
Ground	19294 lb (8751 kg)	19198 lb (8708 kg)

**Lift Capacity 521E XR**

	<b>2.3 yd<sup>3</sup> (1.8 m<sup>3</sup>) Bucket w/Bolt on Edge</b>	<b>2.3 yd<sup>3</sup> (1.8 m<sup>3</sup>) Bucket w/Teeth</b>
Full Height	11443 lb (5190 kg)	11341 lb (5144 kg)
Ground	19101 lb (8664 kg)	18982 lb (8610 kg)

**Lift Capacity 521E XR**

	<b>2.6 yd<sup>3</sup> (2.0 m<sup>3</sup>) Bucket w/Bolt on Edge</b>
Full Height	11512 lb (5222 kg)
Ground	19067 lb (8649 kg)

**Lift Capacity 521E XR - ACS Buckets with Coupler**

	<b>2.1 yd<sup>3</sup> (1.6 m<sup>3</sup>) Bucket w/Bolt on Edge</b>	<b>2.1 yd<sup>3</sup> (1.6 m<sup>3</sup>) Bucket w/Bolt on Edge</b>
Full Height	10512 lb (4768 kg)	10138 lb (4559 kg)
Ground	18148 lb (8232 kg)	17750 lb (8501 kg)

**Lift Capacity 521E XR - JRB Buckets with Coupler**

	<b>2.0 yd<sup>3</sup> (1.5 m<sup>3</sup>) Bucket w/Bolt on Edge</b>
Full Height	10814 lb (4905 kg)
Ground	17924 lb (8130 kg)

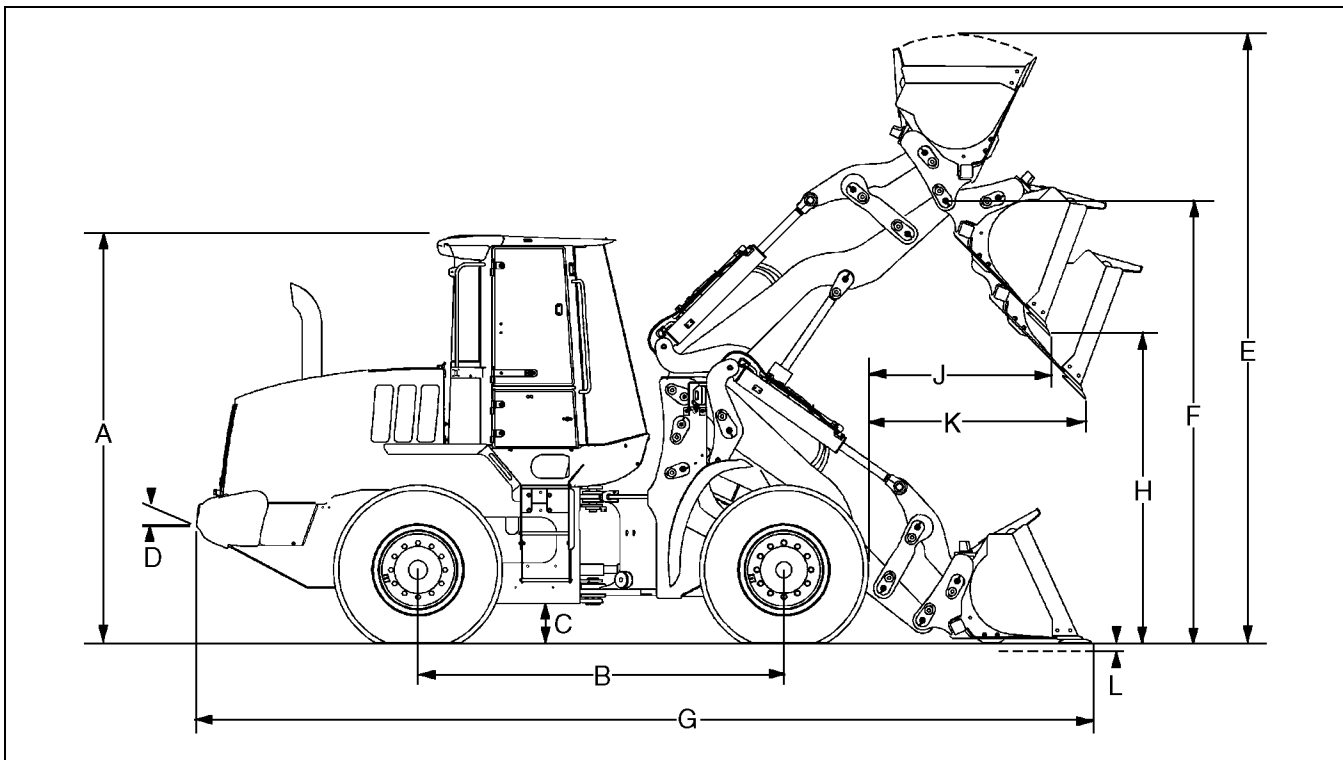

BS07J056

Figure 10

**521E MACHINES - XT LIFT ARM - ACS BUCKET WITH COUPLER  
1.6 M<sup>3</sup> (2.1 YD<sup>3</sup>) MEDIUM DENSITY BUCKET W/TEETH AND SEGMENTED CUTTING EDGE**

SAE bucket capacity

Struck.....	1.38 m <sup>3</sup> (1.81 yd <sup>3</sup> )
Heaped.....	1.61 m <sup>3</sup> (2.10 yd <sup>3</sup> )

<b>A.</b> Height to top of cab .....	3 277 mm (129.0 in)
<b>B.</b> Wheelbase.....	2 750 mm (108.3 in)
<b>C.</b> Ground clearance .....	377 mm (14.85 in)
<b>D.</b> Angle of departure .....	34 degrees

Width -

Overall w/o bucket and with 17.5 X 25 XTLA tires .....	2 389 mm (94.1 in)
Centerline tread with 17.5 X 25 XTLA tires.....	1 900 mm (74.8 in)
Turning radius - outside with 17.5 X 25 XTLA tires .....	4 972 mm (195.8 in)

Turning angle

From center.....	40 degrees
Total angle.....	80 degrees

<b>E.</b> Operating height - fully raised w/spillguard.....	5 019 mm (197.6 in)
<b>F.</b> Hinge pin height - fully raised .....	3 742 mm (147.3 in)
<b>G.</b> Overall length - bucket level on ground .....	6 652 mm (261.9 in)
<b>H.</b> Dump height - fully raised, 45 degree dump.....	2 780 mm (109.4 in)
<b>J.</b> Bucket reach - fully raised, 45 degree dump.....	1 115 mm (43.9 in)
<b>K.</b> Bucket reach - 2.13 m (7 ft 0 in) height, 45 degree dump .....	1 586 mm (62.5 in)
<b>L.</b> Dig depth.....	56 mm (2.2 in)

Tipping load - ISO

Machine straight.....	6 905 kg (15 223 lb)
40 degree turn .....	5 843 kg (12 882 lb)

Operating load - ISO..... 2 922 kg (6 441 lb)

Unit operating mass..... 12 076 kg (26 624 lb)

**NOTE:** Machine operating weights stated are calculated with ROPS cab, heater, air conditioner, 1873 lb. counterweight, 17.5R25 XTLA tires, standard width front and rear fenders, full fuel, 175 lb (79 kg) operator.

CLICK HERE TO **DOWNLOAD** THE COMPLETE MANUAL

- Thank you very much for reading the preview of the manual.
- You can download the complete manual from: [www.heydownloads.com](http://www.heydownloads.com) by clicking the link below



- Please note: If there is no response to CLICKING the link, please download this PDF first and then click on it.

CLICK HERE TO **DOWNLOAD** THE COMPLETE MANUAL