

ORIGINAL INSTRUCTIONS - according to Directive 2006/42/EC, Annex I, 1.7.4.1

1021F
1121F
Stage IV
Wheel Loader

OPERATOR'S MANUAL

Part number 47920033

1st edition English

October 2016



CLICK HERE TO **DOWNLOAD** THE COMPLETE MANUAL

- Thank you very much for reading the preview of the manual.
- You can download the complete manual from: www.heydownloads.com by clicking the link below



- Please note: If there is no response to CLICKING the link, please download this PDF first and then click on it.

CLICK HERE TO **DOWNLOAD** THE COMPLETE MANUAL

Electro-Magnetic Compatibility (EMC)

This machine complies strictly with the European Regulations on the electro-magnetic emissions. However, interference may arise as a result of add-on equipment which may not necessarily meet the required standards. Such interference can result in serious malfunction of the unit and/or create unsafe situations, you must observe the following:

- Ensure that each piece of non CASE CONSTRUCTION equipment fitted to the machine bears the CE mark.
- The maximum power of emission equipment (radio, telephones, etc.) must not exceed the limits imposed by the national authorities of the country where you use the machine.
- The electromagnetic field generated by the add on system should not exceed **100 V/m** at any time and at any location in the proximity of electronic components.

Failure to comply with these rules will render the CASE CONSTRUCTION warranty null and void.

Declaration of conformity

The following page provides a facsimile copy of the “EC” Declaration of Conformity. The EC Declaration of Conformity is the manufacturer’s declaration about machine compliance to relevant EU provisions. Please keep the original document in a safe place. Local authorities may require you to show this document in order to assure compliance of your machine.

Translation of this declaration in your own country language is provided on the reverse page of the original document.

For your better and easier understanding of the document hereafter you’ll find some explanatory notes.

1. Under section 1.2 are listed those options or variants which have safety related functions. Some of them are standard provided, like FOPS or ROPS.
2. Under point **(2)** are listed all information required by EU "Outdoor Noise" Directive **2000/14/EC**. Please refer your own original EC Declaration of Conformity for specific machine information.
3. Generic serial number for this machine type. Sequence of letters and numbers may vary depending on machine configuration.
4. EC Declaration of Conformity serial number. Please make reference to this number when requiring information or support about declaration.
5. Signature of a person authorized to sign the document on behalf of the company.

Burn prevention

⚠ WARNING

Battery acid causes burns. Batteries contain sulfuric acid.

Battery electrolyte contains sulfuric acid. Contact with skin and eyes could result in severe irritation and burns. Always wear splash-proof goggles and protective clothing (gloves and aprons). Wash hands after handling.

Failure to comply could result in death or serious injury.

W0120A

⚠ CAUTION

Burn hazard!

Hot coolant can spray out if you remove the filler cap while the system is hot. After the system has cooled, turn the filler cap to the first notch and wait for all pressure to release before proceeding.

Failure to comply could result in minor or moderate injury.

C0043A

⚠ CAUTION

Burn hazard!

The engine and exhaust system become hot during operation. To prevent burns, open the engine compartment and allow the components to cool to a comfortable touch temperature before you work inside the engine compartment.

Failure to comply could result in minor or moderate injury.

C0178A

- When the battery electrolyte is frozen, the battery can explode if, you try to charge the battery, or if you try to boost start and run the engine. To prevent the battery electrolyte from freezing, try to keep the battery at full charge. If you do not follow these instructions, you or others in the area can be injured.
- Hot coolant can spray out if the cooling system cap is removed. To remove the cap, let the cooling system cool, turn to the first notch, wait until the pressure is released, then remove the cooling system tank cap.
- Hot surfaces within the engine compartment can cause burns: Following operation, the engine and exhaust system will be very hot. To prevent burns, open the engine compartment and allow components to cool to comfortable touch temperature before working inside engine compartment.

Lower load or tool slowly



LEEN11T0016AA 12

Turn machine left swing load left
To stop movement, stop moving hand and make a fist.

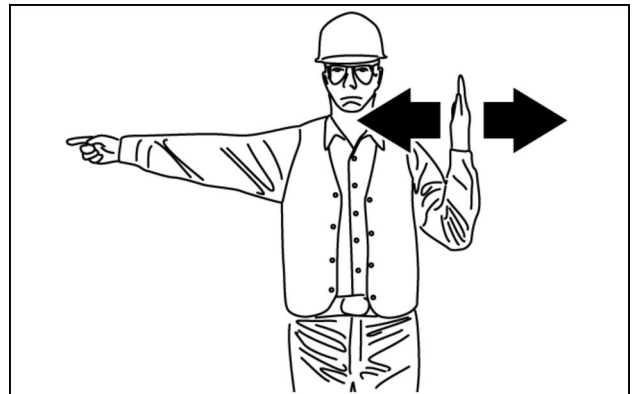

LEEN11T0017AA 13

Turn machine right swing load right
To stop movement, stop moving hand and make a fist

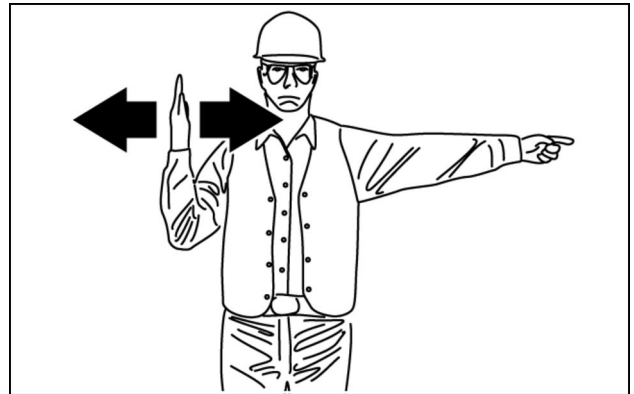

LEEN11T0018AA 14

Raise boom

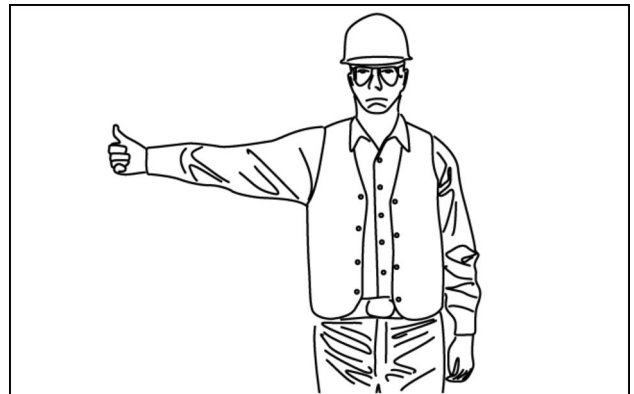

LEEN11T0019AA 15

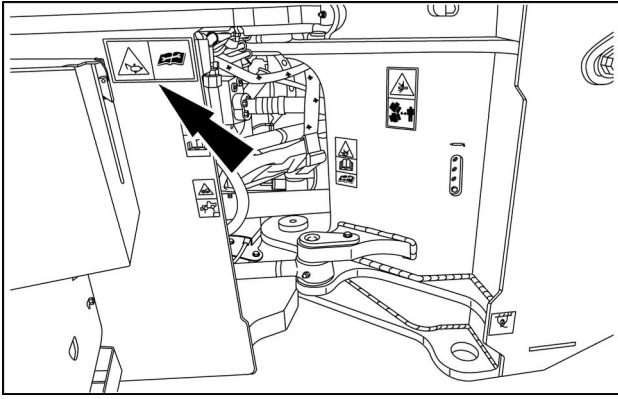

LEIL15WHL0705AA 15

Location: right-hand side of the machine, near the articulation area. See 7-5 in this manual for more information.

WARNING

Pressured system hazard!
Release all pressure before working systems which have an accumulator.
Failure to comply with this warning could result in death or serious injury.

ISO decal number: 328903A1

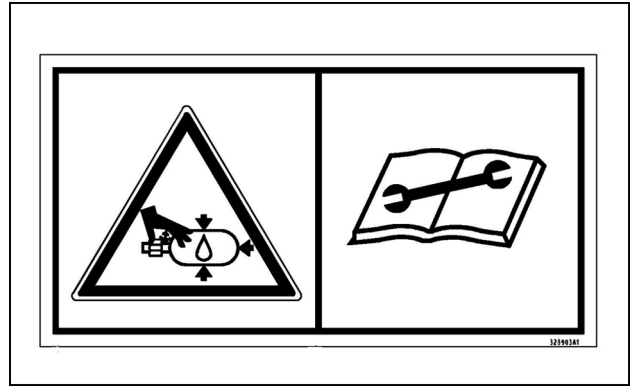

328903A1 16

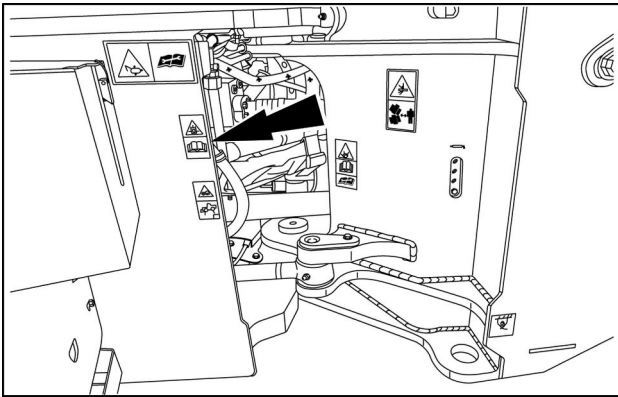

LEIL15WHL0705AA 17

Location: right-hand and left-hand side of the machine, near the articulation area. See 7-5 in this manual for more information.

WARNING

Pressurized system hazard!
Release pressure before maintenance.
Failure to comply with this warning could result in death or serious injury.

ISO decal number: 333269A1

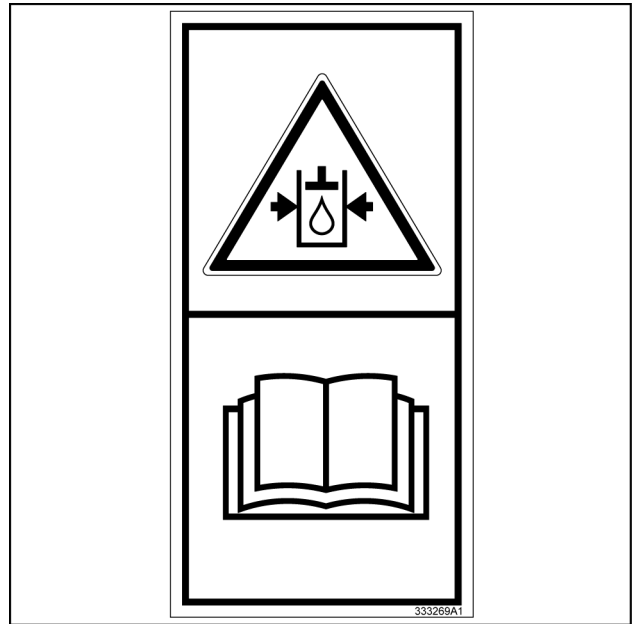

333269A1 18

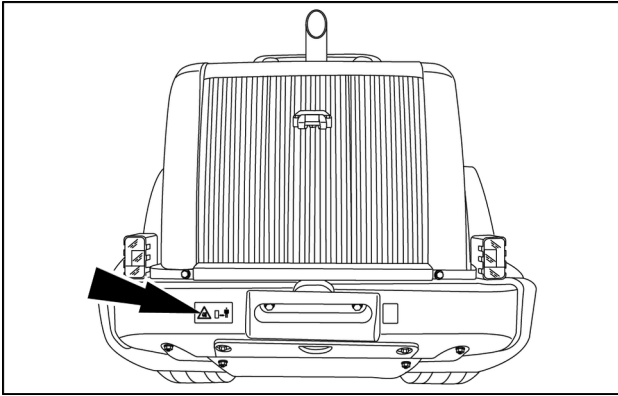

LEIL16WHL0494AA 55

Location: rear side of the machine.

DANGER

Run-over hazard!

Keep clear of the machine.

Failure to comply with this warning will result in death or serious injury.

ISO decal number: 328753A1



328753A1_ 56

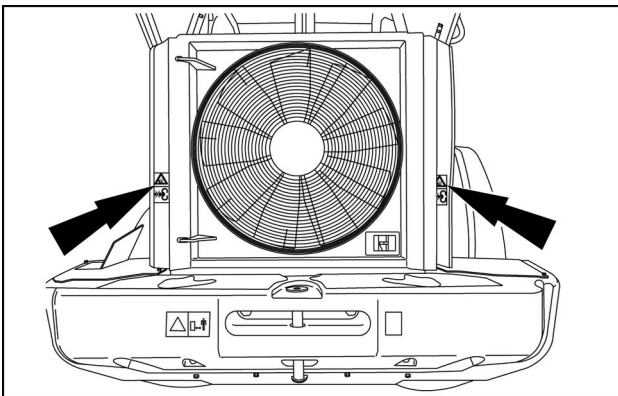

LEIL15WHL0698AB 57

Location: on the cooling frame on the rear side of the machine.

WARNING

Entanglement hazard!

Keep clear or stop before servicing.

Failure to comply with this warning could result in death or serious injury.

ISO decal number: 87488609

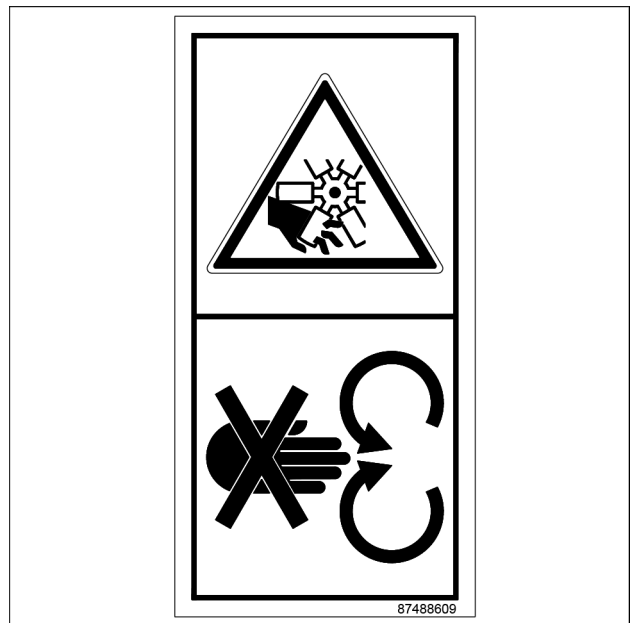

87488609_ 58

Operator's seat

Overview

▲ WARNING

Loss of control hazard!

DO NOT make seat adjustments while the machine is in motion. All seat adjustment should be made with the machine stationary and the parking brake applied. Failure to comply could result in death or serious injury.

W0293A

Standard operator's seat

1. Lumbar adjustment knob - Turn the knob clockwise to increase the lumbar support. Turn the knob counter-clockwise to decrease the lumbar support.

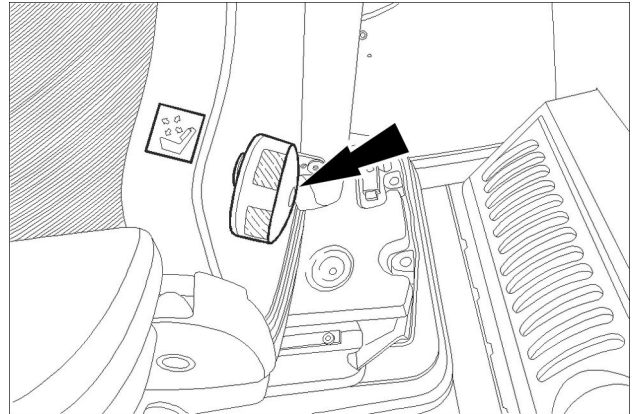

RCPH10WHL087BAL 1

2. Armrest height control adjustment - Turn the knob to raise or lower the armrest to the desired position.

NOTE: each armrest will pivot to the up position.

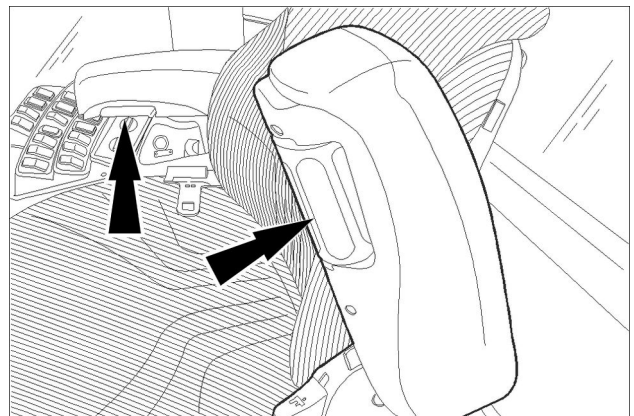

RCPH10WHL085BAL 2

3. Recliner adjustment handle - Lift up on handle, move the backrest to the desired position, release the handle to lock in position.

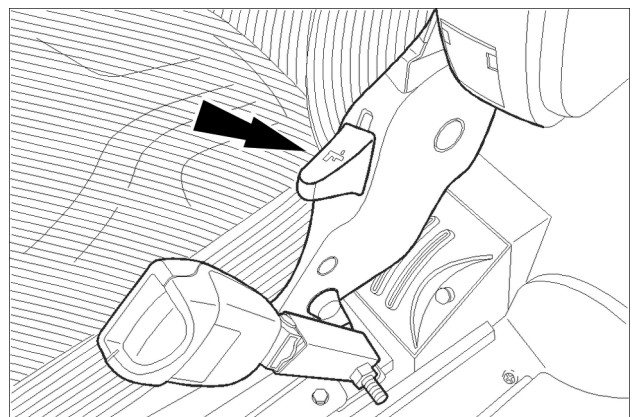

RCPH10WHL084BAL 3

Steering column

Ignition switch

The ignition switch has four positions:

Accessory position

This position will energize the optional radio only. It will not energize the instruments or start the engine.

OFF position

In this position, all switch controlled current is OFF. Turn the key to OFF to stop the engine. Remove the key and turn the Master Disconnect Switch to OFF.

START position

Turn the key to this position to engage the starter motor to start the engine. The switch is spring loaded and will return to the ON position when released.

ON position

This position will energize all electrical systems. The key will return to this position after you release the key from the start position.

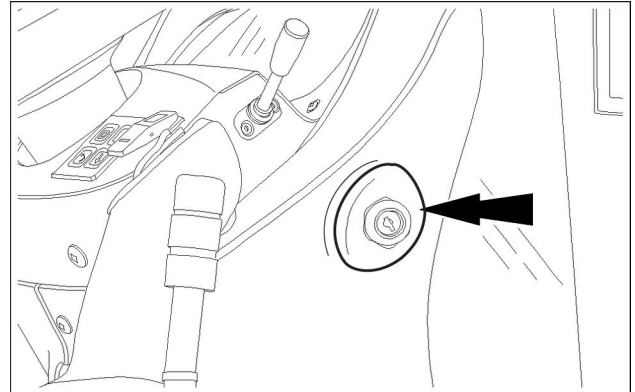

LEIL16WHL0092AB 1

Horn and turn signal

The horn and the turn signal lever is located on the right-hand side of the steering wheel.

⚠ WARNING

Hazard to bystanders!

Always sound the horn before starting the machine. Make sure the work area is clear of other persons, domestic animals, tools, etc. before you operate the machine. Never allow anyone in the work area during machine operation.

Failure to comply could result in death or serious injury.

W0304A

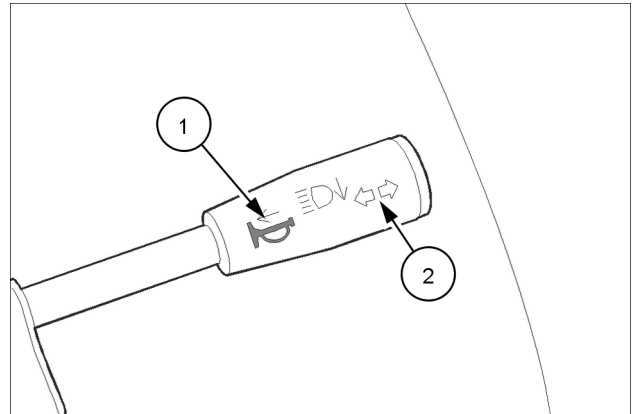

RCPH10WHL115BAL 2



1. Horn - Push the horn lever in to actuate the horn.

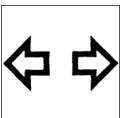

2. Turn signal lever - Push the control lever up to signal a left turn. Pull the lever down to signal a right turn. The lever must be moved manually to the center position to stop the signals.

Two function valve

Two function valve - one control lever

1. LIFT ARM AND BUCKET CONTROL

- A. FLOAT (DETENT) - This is a detent position. When in the FLOAT (detent) position, the loader bucket can follow the level of the ground without movement of the control lever
- B. LOWER
- C. HOLD - The loader arms and bucket will not move when the control lever is in the HOLD position. When released, the control lever will automatically return to the HOLD position. You must manually move the control lever from the FLOAT position to the HOLD position.
- D. RAISE
- E. DUMP
- F. ROLLBACK

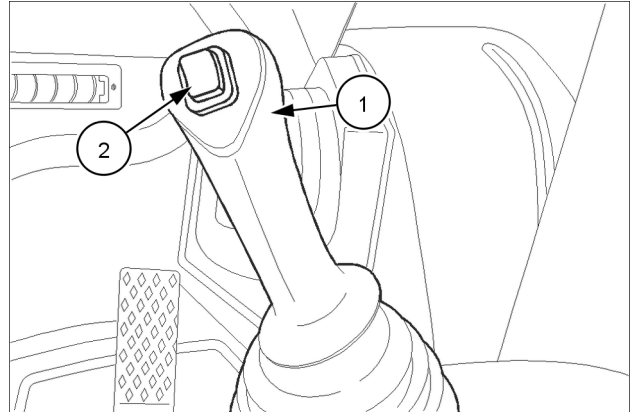

RCPH10WHL121BAL 1

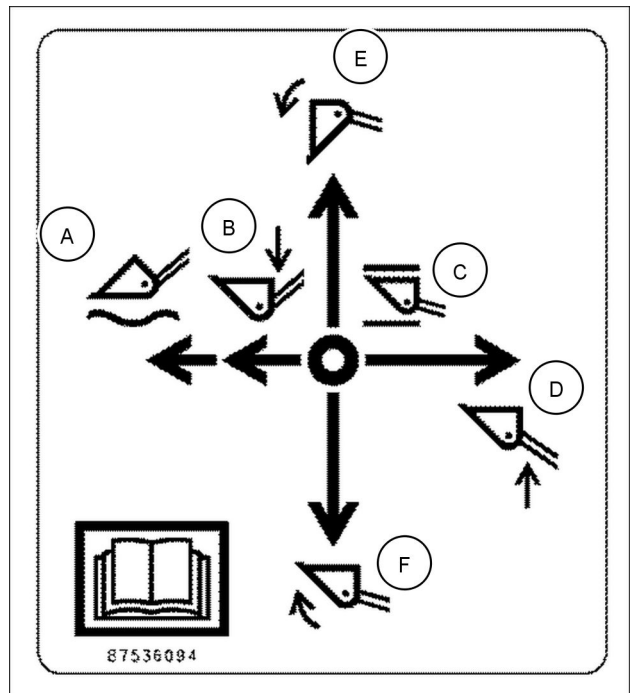

87536094

RCPH10WHL008AAL 2

Exterior controls

Hood switch and master disconnect

▲ WARNING

Automatic closure!

Keep your hands and body and all personnel clear of the machine hood as it closes.

Failure to comply could result in death or serious injury.

W0048A

Hood Switch

The hood switch is located on the left-hand side of the machine. A locking mechanism is provided for the hood switch cover. Use the machine key to open and close this cover.

1. Insert the key. Make sure to completely insert the key for proper operation.

NOTICE: damage can occur to the key or locking mechanism if key is improperly inserted and turned.

2. After releasing the lock, remove the key and open the cover.

3. The hood switch will automatically raise the hood on the machine. Keep all tools, service equipment, and personnel away from the hood when it is automatically opening and closing.

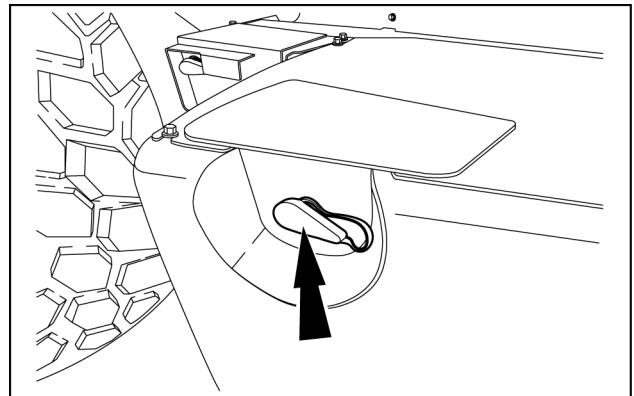

LEIL15WHL0739AB 1

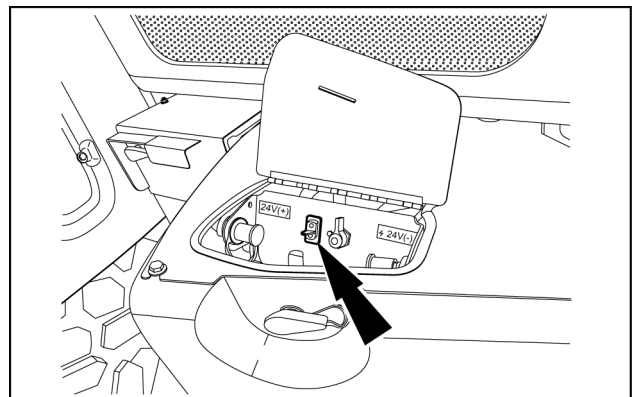

LEIL15WHL0740AB 2

4. Push up on the switch to raise the hood. The switch will remain in the up position for hands free opening. To close the hood, push down on the switch. As a built in safety measure, the down control must be held in order to lower the hood.

Inducement and validation re-starts

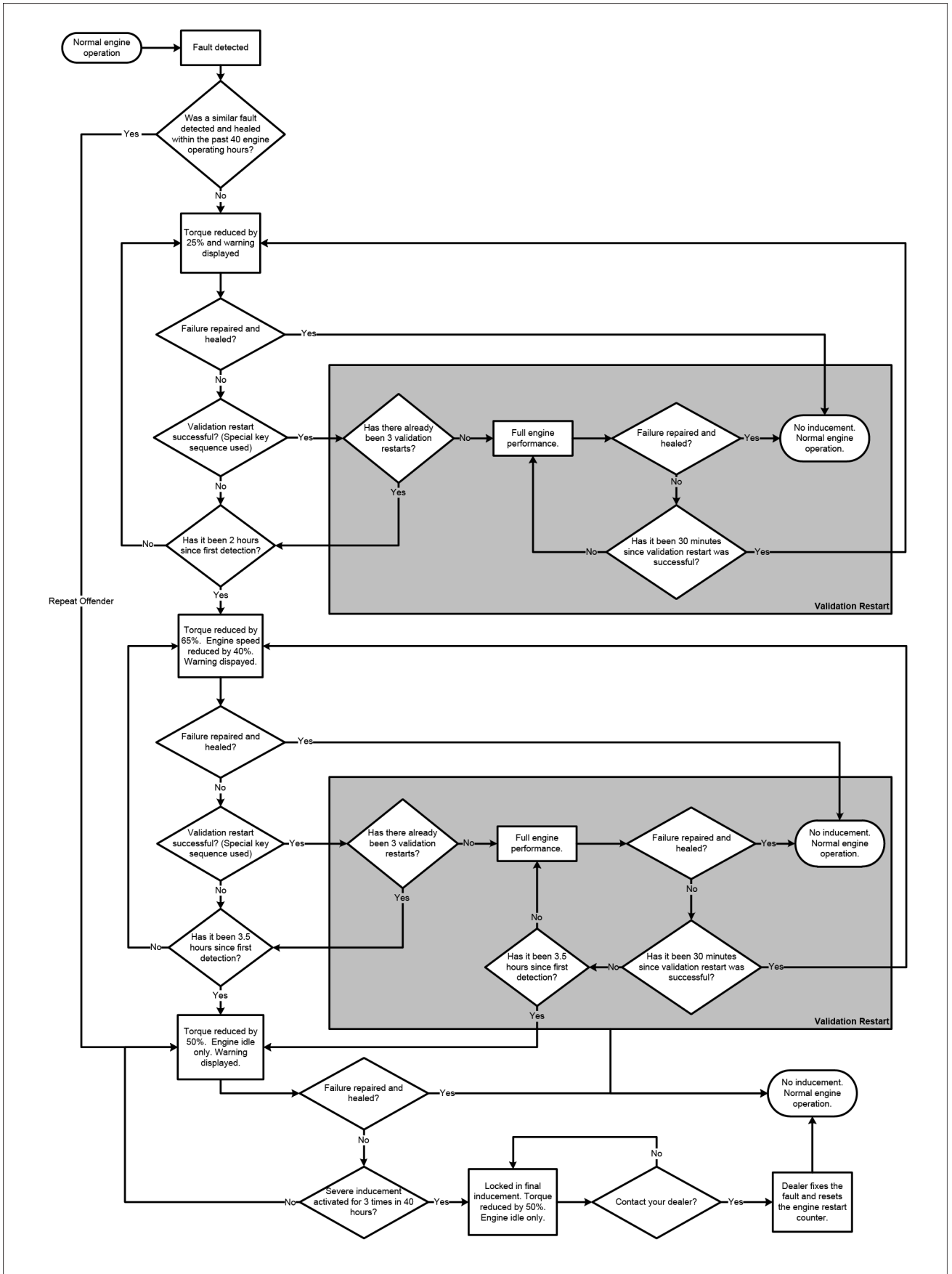

LEIL14WHL0394HA 3

Press the confirm key to reset to the desired trip screen.

The trip screen will indicate a reset message. At this screen, press the confirm key to clear the numbers and reset the trip information. The current date and time will display automatically. The hours, fuel consumption, and fuel used per hour will reset and revert to zero.

Press the escape key to return to the main driving screen and lock settings into memory. The screen will begin to record time and fuel usage immediately.

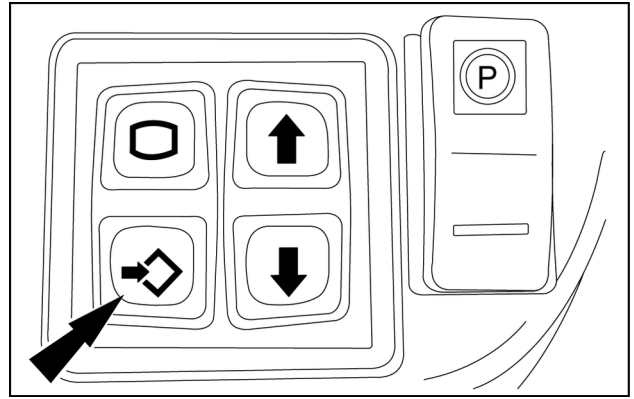

LEIL15WHL1707AA 11

WARNING DISPLAY AND ERRORS

JOYSTICK STEERING RELATED ERROR HANDLING

All JSS related errors will be displayed only while the JSS activation switch is in ON position except for the red error "Short to power on power supply" and the failure of the activation switch which will be always displayed when present.

All JSS related errors will be reset by switching the JSS activation switch to the OFF position.

While ignition is ON and JSS is deactivated the software will check if the JSS Power Supply is off. Check JSS Output Control is low/open → if not a red error will be displayed "Short on JSS power supply JSS active".

Error Item	Location of Error Detection	Message
1812y	JSC	Open Circuit, Short to Battery or Short to Ground at JSS armrest switch.
1816y	JSC	Open Circuit / JSS activation switch mechanical defect.
1820y	JSC	Check JSS Relay, JSS Valve, JSS Joystick power supply connections.
1821r	JSC	Short to ground on JSS Relay 85/AIC1.21 or short to Power on Relay 86/87a. Or Activation Switch failure.
1823y	JSC	JSS RELAY, GROUND CONNECT., BAD ELEC. CONNCT. Permanent ground at JSS Relay (87) open circuit or short to power.
1824y	JSC	Short to battery at activation button. Activation switch failure.
1829y	JSC	Joystick Steering is not calibrated.
1830y	JSC	Open circuit between activation switch Pin 3 and C5.E Pin 1.
1831y	JSC	JSC CONTROLLER, WRONG OPERATION. JSC controller internal fault.
1832y	JSC	JSC CONTROLLER, JSC SIGNAL IN, OUT OF LIMITS. Input signal from JSS joystick to JSC controller out of limits. (Joystick Neutral: USignal>40%UBat + <60%UBat; Joystick Actuated: USignal>20%UBat + <80%UBat)
1833y	JSC	Output signal from JSC controller to valve out of limits. Check connector of JSS valve and JSC controller.
1834y	JSC	JSS CONTROLLER, JSC OUTPUT, SC to BAT Power is applied to one of the JSC controller outputs. Check electrical connection for short to power. Or JSC internal Relay is defect.
1835y	AIC	JSS-valve/Pin4 JSC/Pin5 short to power, short to ground or open circuit.
1836y	JSC	JSS CONTROLLER, BOARD TEMPERATURE, OUT OF LIMITS Temperature on the JSC board is <-40°C or >+85°C; Check ambient temperature or short circuit at JSC power outputs.
1837y	JSC	JSS CONTROLLER, SWITCHED POWER, OUT OF LIMITS Switched power supply at JSC Pin3 is out of limit; Check elect connection for electrical transients, burst or drifts.
1838y	JSC	Neutral Sw out of range.
1841y	JSC	JSS valve internal error, spool position not accurate or signal voltage out of range.
1842y	JSC	JSS valve Pin2 (alarm signal) open circuit.
1843y	JSC	Pilot pressure switch open when JSS is deactivated. High pilot pressure on JSS valve even when JSS is not active. Pilot Dump valve stuck close or short to power on valve power supply. Or open circuit on JSS pilot pressure switch lines or JSC/Pin8.
1844y	JSC	Pilot pressure switch short to ground.

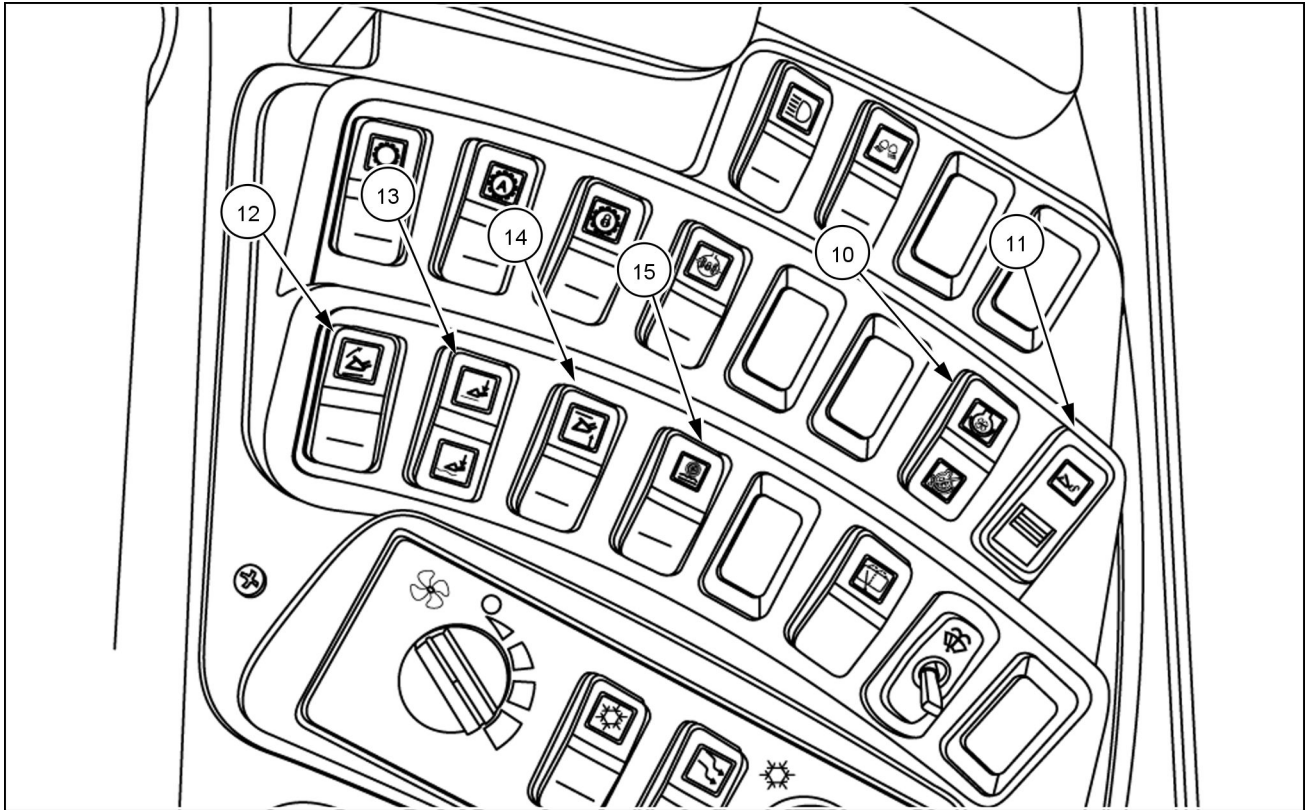

RCPH10WHL079FAH 4

10. Fan reverse switch

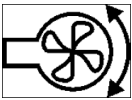

To use the fan reverser let the machine idle in neutral. Depress the fan reverser switch and depress the throttle to high idle for a minimum of 10 seconds or until debris stops blowing out of the coolers. Return the machine to idle and release the fan reverser switch. This is a three-position switch. Push the upper part of the switch for momentary reversal as described above. The center position of the switch is the automatic position, and the lower position disables the automatic fan.

11. Coupler engagement switch (if equipped)

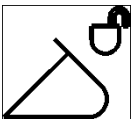

This switch allows engagement of the attachment from the operator's compartment. Slide the locking plate toward the center of the switch. Push down on the top of the switch to retract pins for the attachment. The switch lamp will illuminate when the pins have been retracted. The switch will lock the pin in the extended position when the bottom of the switch has been pressed and the pins are extended.

12. Return to dig switch

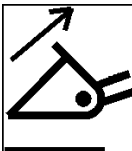

Push on the top of the function switch for the ON position. This will allow the bucket to return to level with the ground for digging.

13. Return to travel detent switch



The return-to-travel switch is used to automatically return the loader bucket to the travel position after you have dumped the loader bucket. Push down on the top of the return-to-travel switch to engage the return to travel detent. Push the bottom of the switch for the float detent position.

Starting the unit

Starting the engine

▲ WARNING

IMPROPER OPERATION OF THIS MACHINE CAN CAUSE DEATH OR SERIOUS INJURY.

MAKE SURE THAT EVERY OPERATOR:

- is instructed in the safe and proper use of this machine.
 - reads and understands the operator's manual for this machine.
 - reads and understands **ALL** safety signs on the machine.
- Failure to comply could result in death or serious injury.

W0188A

Before operating the machine

Before operating this machine, complete the following procedures:

1. Check the level of all fluids (engine oil, fuel, **DEF/ AdBLUE®**, hydraulic fluid, and coolant) and make sure that the fluids and lubricants are suitable for prevailing conditions.
2. Carry out the daily maintenance operations.
3. Inspect the machine, look for any signs of possible leakage and check the hoses. Tighten or replace as necessary.
4. See "Run in period of a new machine" in this chapter, if the machine is new or if the engine has been reconditioned.
5. Check the tires for any visible damage. Replace or repair as necessary. Check for correct tire air pressure and adjust pressure if necessary.
6. Clean the steps and hand holds. Grease, oil, mud, or ice in winter on the steps and access handles can cause accidents. Make sure they are kept clean at all times.
7. Clean or replace any decals which are illegible. See "Safety signs" – Chapter 2.
8. Make sure that the engine access panels and all doors are properly closed and latched.
9. Secure the cab door in either fully closed or fully opened position.
10. Remove any obstructions which hinder visibility. Clean the windshield, the windows and the rear view mirrors.
11. Check that no tools or other items have been left on the machine or in the operator's compartment.
12. Make sure no one is on or under the machine. The operator must be alone on the machine.
13. Make sure no one is standing in the machine working area.
14. Find out about current safety measures in use on the work site.
15. Work out a convenient means of escape from the machine (emergency exit via the windshield, the rear or side window glass) in the event of the cab door being jammed or the machine turning over.
16. Before undertaking any travel or working operations during hours of darkness, make sure the lighting and signaling equipment is fully operative.
17. Adjust the seat so that you can apply the foot brakes when your back is against the seat backrest.
18. Fasten and adjust the seat belt.
19. With the engine running and at operating temperature, check the instrument panel for correct indications.
20. Check the loader controls for correct operation.

Ride control



Ride control is an optional feature that increases the ride comfort of the wheel loader over all types of terrain with either an empty or loaded bucket. It allows faster speeds during operation, resulting in increased productivity and operator comfort. It will also reduce shock loads to the wheel loader for reduced tire flex, structural fatigue and vibration, resulting in longer component life and reduced costs. Ride control will reduce fore and aft pitching motion during travel to allow faster speeds in load and carry applications.

The machine is equipped with a 3-position Ride control switch (manual, auto, and off). Most commonly, the operator will choose to leave this switch in the automatic (center) position. With ride control active, the green indicator light will illuminate anytime the machine is traveling faster than **5 km/h (3.1 mph)** indicating that the ride control is functioning. Ride control will disengage automatically at slower speeds for loading and unloading. Ride control can be left ON at all times, whether loading or roading.

To turn Ride control OFF, push on the bottom of function switch for the OFF position.

The top position of the switch turns ride control on in the manual position.

NOTE: *turn Ride control OFF when you operate the bucket in fine grading operations or when precision placement of a load suspended from the bucket or other attachment is required*

Automatic mode

Automatic mode operation

To put the transmission in the automatic mode, press the top of the auto shift switch.

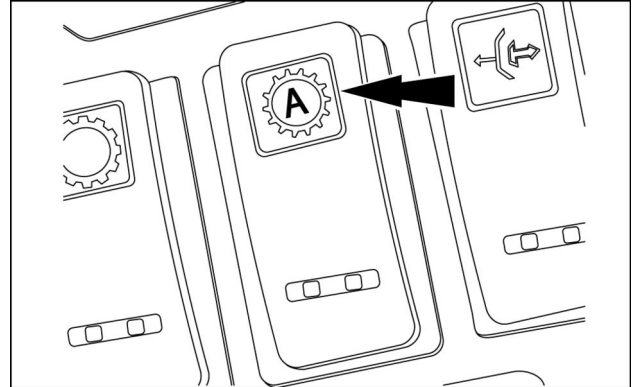

RCIL10WHL197BAL 1

Automatic shifting mode

When the transmission is in the automatic mode, the transmission will start out in first gear or second gear (dependent upon gear minimum setting), and automatically shift up until the gear selected has been reached. The transmission will also shift down automatically as the speed decreases.

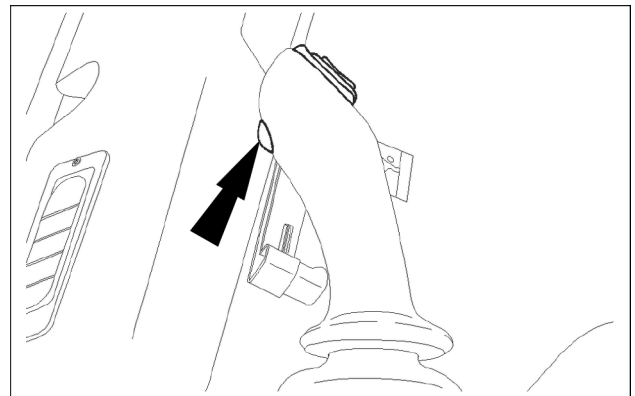

LEIL16WHL0132AA 2

Down-shift button, automatic mode

Use the down-shift button to shift down through the gears in single steps. Each time you press the switch, the transmission shifts down one gear range until reaching the first gear. Once the down-shift button has been pressed down, the transmission maximum gear allowed is lowered. The down-shift button will return to the automatic mode in one of the two cases, as follows:

1. When the transmission control lever changes gear
2. When the transmission control lever is moved to NEUTRAL and then to FORWARD or to REVERSE

NOTE: when the operator selects the Automatic Mode, the Automatic Mode indicator will be shown on the multi-function display.

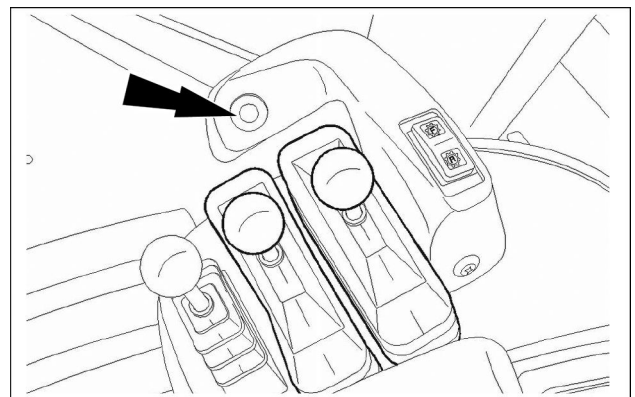

LEIL16WHL0133AA 3

5 - TRANSPORT OPERATIONS

Road transport

Safety rules

▲ WARNING

Crushing hazard!
Engage the safety lock link before service or transport.
Failure to comply could result in death or serious injury.

W0154A

▲ WARNING

Driving hazard!
Know all rules, regulations, laws, and required safety equipment for transporting or operating this machine on a road or highway. See your dealer to obtain a rotating beacon, backup alarm, Slow Moving Vehicle (SMV) emblem, and other safety equipment.
Failure to comply could result in death or serious injury.

W0154A

▲ WARNING

Transport hazard!
The machine can slip or fall from a ramp or trailer. Make sure the ramp and trailer are not slippery. Remove all oil, grease, ice, etc. Move the machine on or off the trailer with machine centered on the trailer or ramp.
Failure to comply could result in death or serious injury.

W0152A

▲ WARNING

Transport hazard!
Always use the primary steering when loading or unloading the machine for transport. Do not use joystick steering when loading or unloading the machine from a truck or trailer.
Failure to comply could result in death or serious injury.

W0448A

Make sure you know the safety rules and regulations before transporting the machine. You must know the rules or laws for transportation and safety that are used in each

area that you will be in. Make sure that the truck and machine are equipped with the correct safety equipment.

6 - WORKING OPERATIONS

Preparing for work

Operating tips

⚠ WARNING

Impact hazard!

Bucket edge or teeth can catch on frozen surfaces or buried objects during surface scraping operations. Before operation, inspect the area for hazardous objects. Operate the machine at slow speed around objects.

Failure to comply could result in death or serious injury.

W0459A

This wheel loader, with standard equipment and authorized attachments, is intended to be used for above ground level digging and general earth moving purpose such as land leveling, truck loading, material rehandling and ditch cleaning. If the machine is to be used for lifting objects, make sure that the machine is properly equipped and follow the instructions and safety precautions in this manual.

Leveling operation

Always operate the machine in reverse when leveling the surface.

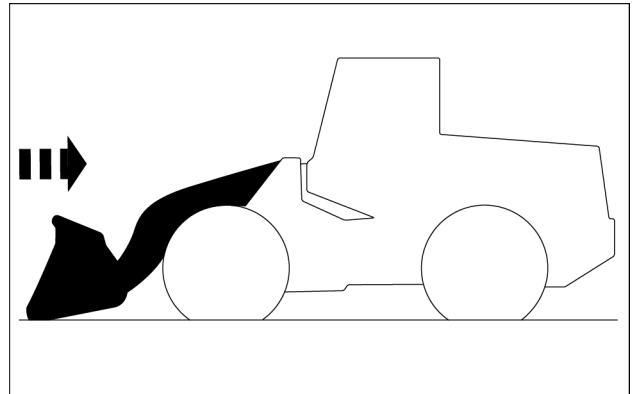

LEIL16WHL0036AB 1

Pushing operation

When pushing material, do not set the bucket dumping angle more than 20°.

NOTICE: the bucket **MUST NOT** be in the **FULL DUMP** position during the pushing operation.

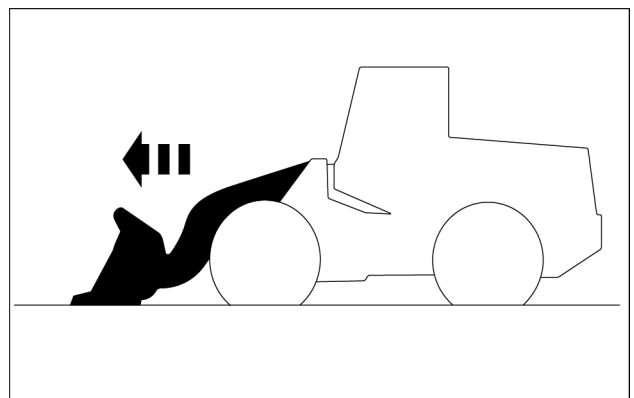

LEIL16WHL0037AB 2

CLICK HERE TO **DOWNLOAD** THE COMPLETE MANUAL

- Thank you very much for reading the preview of the manual.
- You can download the complete manual from: www.heydownloads.com by clicking the link below



- Please note: If there is no response to CLICKING the link, please download this PDF first and then click on it.

CLICK HERE TO **DOWNLOAD** THE COMPLETE MANUAL

Forward, neutral, reverse (F-N-R) Switch

- A. Forward
- B. Neutral
- C. Reverse

An F-N-R (forward-neutral-reverse) switch is located on the left-hand armrest as a convenience feature when using the joystick steering option. The features and functions of the switch are identical to the standard F-N-R switch. This F-N-R switch is only active when the joystick steering has been activated.

To actuate the armrest F-N-R switch, fulfill the following necessary conditions:

1. Stop the machine
2. The engine must be running
3. Set the armrest F-N-R switch in NEUTRAL
4. Set the standard transmission control lever in NEUTRAL
5. Release the parking brake

NOTICE: the gearshift lever located on the steering column has always priority.

Kick-down switch

The kick-down switch is used to shift down through the gears in single steps. Each time the switch is pressed, the transmission will shift down one gear range until first gear is reached. Once the kick-down switch has been pressed down, the transmission maximum gear allowed is lowered. It will return to the automatic mode when the transmission control lever gear changes, or the transmission control lever is moved to NEUTRAL and then to FORWARD or to REVERSE.

When the operator selects the Automatic Mode, the multi-function display will show the Automatic Mode indicator.

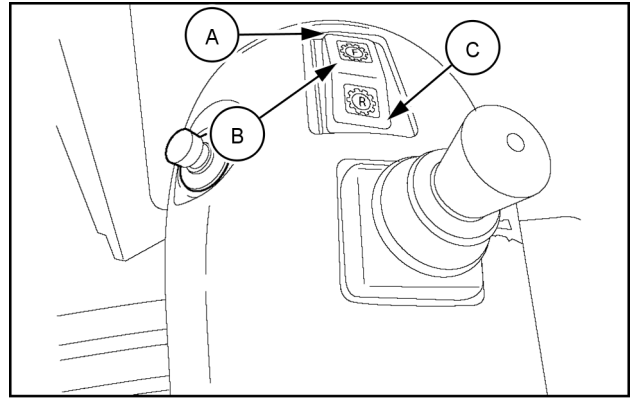

RCIL10WHL189BAL 14

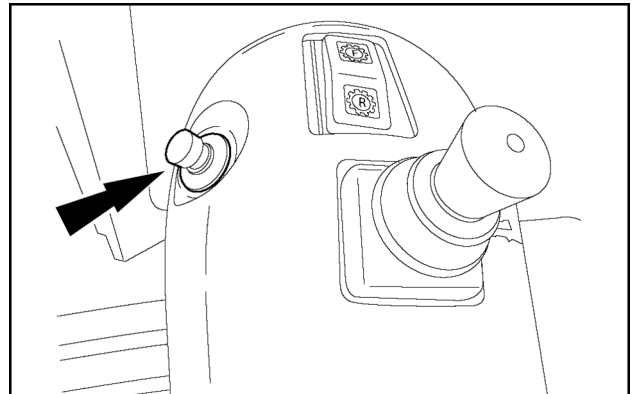

RCIL10WHL189BAL 15

- Biodiesel oxidation, which can lead to the formation of deposits that can harm the fuel injection system.

NOTICE: any problem in the engine fuel injection equipment associated with non-compliance to the following conditions for biodiesel fuel handling and maintenance will not be covered for Warranty by CASE CONSTRUCTION.

Purchase biodiesel fuel from a trusted supplier who understands the product and maintains acceptable fuel quality.

The use of biodiesel blends up to B7 will not void the CASE CONSTRUCTION warranty as long as the following conditions for biodiesel fuel handling and maintenance are stringently followed:

Biodiesel fuel must be pre-blended by the supplier. Mixing biodiesel fuels on-site can result in an incorrect mixture that could damage the engine and/or fuel system.

NOTICE: CASE CONSTRUCTION may void your warranty if the problem is associated with poor fuel quality due to improper blending. It is the responsibility of the fuel supplier and/or yourself to ensure the right type of fuel and blend is delivered and used.

Storage

The machine should not be stored for more than 6 months with biodiesel in the fuel system. For longer storage time, it is strongly suggested that only regular **EN 590** or #2 diesel fuel is used.

NOTE: if storage for longer than 6 months is necessary, the engine must be run on regular **EN 590** or #2 diesel for a minimum of 20 hours to flush the biodiesel fuel out of the fuel system prior to storage.

Biodiesel is highly hygroscopic and tends to collect water more than diesel fuel. This increases the risk of algae and bacteria growth which can cause severe damage to the fuel injection system. Keep the machine fuel tanks and on-site storage tanks as full as possible to limit the amount of air and water vapors inside the tank. Drain water from the tanks at least once a week.

NOTICE: use only CASE CONSTRUCTION approved biocide additives on Tier 4b engines with an exhaust aftertreatment system.

Critical Warnings



The Stop Master Indicator is a critical warning display. See Critical Warning Displays. When the Stop Master indicator illuminates, IMMEDIATELY bring the machine safely to a stop, and turn the engine OFF.

Display	Description	Corrective Action
	Moderate engine power loss has begun, up to 65 % torque reduction and 40 % engine speed within 40 min of engine running time.	DEF/AdBLUE® quality/concentration is questionable. Drain the tank and discard the DEF/AdBLUE® . Fill with new DEF/AdBLUE® . NOTE: see "Refilling the DEF/AdBLUE® tank" section for important tank draining information.
	SCR fault/failure detected. Up to 65 % torque reduction and 40 % engine speed reduction within 40 min .	Contact your local authorized dealer for repair.
	DEF/AdBLUE® level is less than 5 % of tank volume (0 % will be displayed). Up to 65 % torque reduction and 40 % engine speed reduction within 40 min of engine running time.	Refill DEF/AdBLUE® immediately and reset the system by cycling the key switch OFF then ON.
	When the tank has reached 0 % level, there is a 50 % torque reduction, and engine speed is limited to low idle within an additional 30 min of engine run time.	Refill DEF/AdBLUE® immediately and reset the system by cycling the key switch OFF then ON.
	DEF/AdBLUE® quality/concentration is questionable 60 min after the initial warning. Up to 65 % torque reduction and 40 % engine speed reduction within 40 min of engine running time.	Drain DEF/AdBLUE® tank, clean and refill with approved DEF/AdBLUE® solution. Contact your local authorized dealer if failure persists. NOTE: see "Refilling the DEF/AdBLUE® tank" section for important tank draining information.
	SCR fault/failure detected. Up to 65 % torque reduction and 50 % engine speed reduction within 30 min .	Contact your local authorized dealer for repair, cycle key, or validation re-start.

Clean Up Catalyst (CUC)

The Clean Up Catalyst (CUC) is located at the end of the SCR catalyst. The CUC converts the ammonia (NH_3) slip to nitrogen (N_2) and hydrogen (H_2). The CUC ensures that the ammonia slip to ambient is minimal.

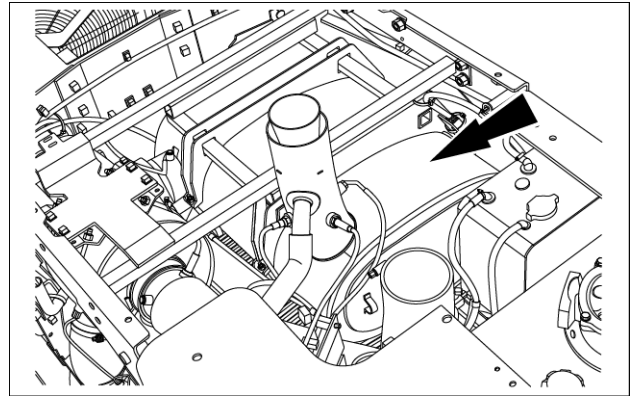

LEIL15WHL0684AB 4

Exhaust flap

The exhaust flap is a device located between the turbine and the exhaust system. The exhaust flap is equipped with a throttle valve which manages the rate and the "light off" temperature of the exhaust gas. The "light off" temperature indicates the temperature at which the catalytic process is initiated.

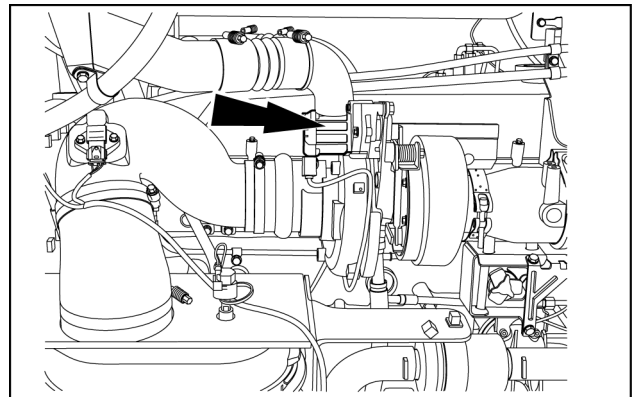

LEIL15WHL0681AB 5

Glossary

Acronym	Definition
DEF	DEF/AdBLUE®
ISO	International Organization for Standardization
MSDS	Material Safety Data Sheet
NOx	Nitrogen Oxide
PPE	Personal Protective Equipment
SCR	Selective Catalytic Reduction
ULSD	Ultra Low Sulfur Diesel
SM	Supply Module
DOC	Diesel Oxidation Catalyst
CUC	Clean Up Catalyst

Units of measure

Symbol	Definition
C	Centigrade
F	Fahrenheit
°	Degree
%	Percent
<	Less than
>	Greater than
mg/kg	Milligrams per kilogram

Lift and tilt cylinder

Grease the lift and the tilt cylinder at the remote grease locations (left-hand and right-hand side of the machine, near the articulation area).

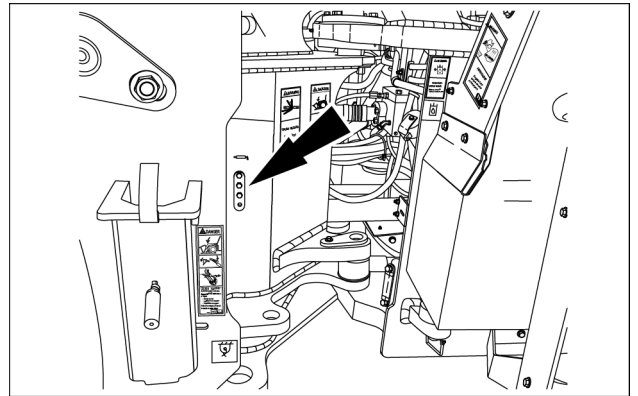

LEIL16WHL0999AA 3

Engine oil and filter (Initial) - Replace

Change the engine oil and filter when the hour meter registers 100 hours for a new machine during the initial run-in period. Change the engine oil and the filter every 500 hours thereafter or more frequently when the engine operating conditions are severe.

Prior operation:

Keep all non-authorized personnel clear of the area. Park the machine on level ground, in neutral with the parking brake applied and the attachment lowered to the ground.

Service specifications	
Type of oil	CASE AKCELA UNITEK 10W-40
1021F total capacity	28.5 l (30.1 US qt)
1121F total capacity	28.5 l (30.1 US qt)

1. Lower the bucket/attachment to the ground. Install the transport/service link into the locked position.

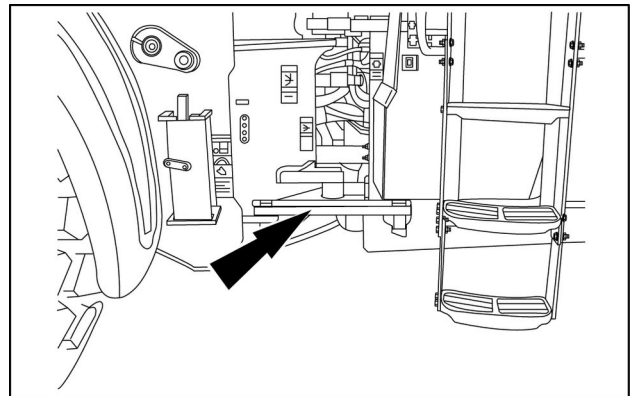

LEIL15WHL1782AA 1

2. The remote drain for the engine oil is located on the lower right-hand rear side of the machine behind the tire.

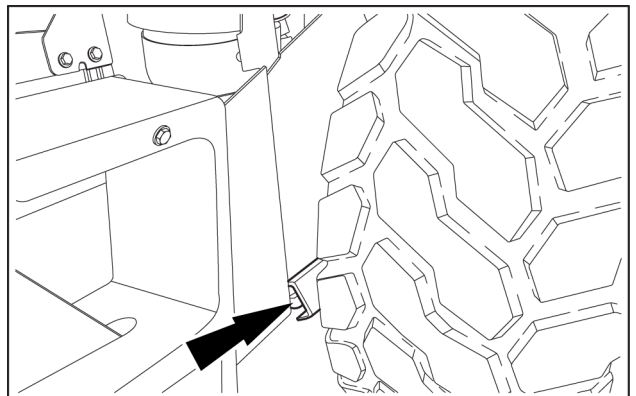

LEIL15WHL0702AB 2

3. Attach a drain hose to the remote drain plug. Use a suitable container to collect the used oil, and drain the engine oil completely.

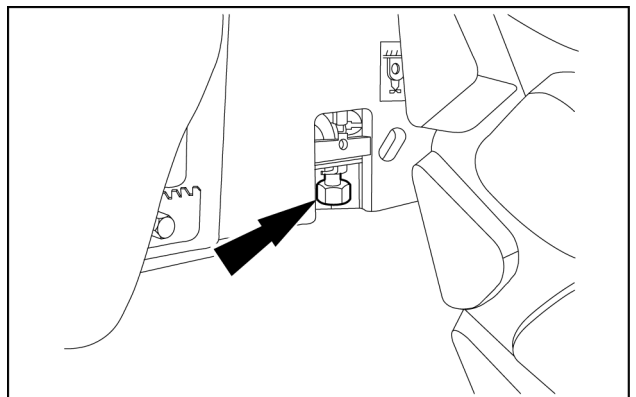

LEIL15WHL1783AB 3

Axle cooler filters

7. Axle cooler filters are located on the right-hand side of the machine beneath the steps. The shield can be removed for easier access if desired.

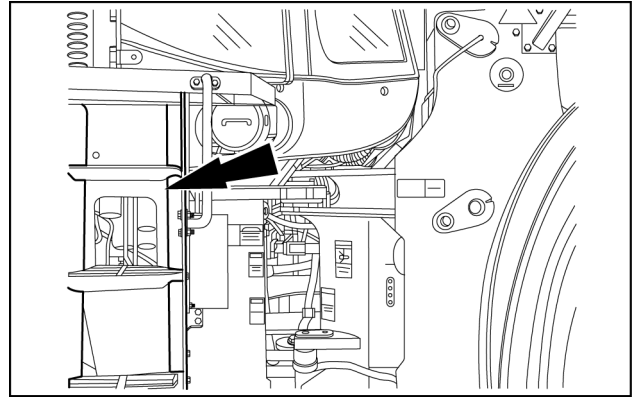

LEIL15WHL1789AB 4

8. Clean the area around the axle cooler filters. Remove filters by turning counterclockwise.
9. Apply a thin film of clean axle oil to the gasket of the new filter. Make certain proper contact is made with the base of the filter. Hand tighten then turn 1/2 to 3/4 turn more. DO NOT USE A FILTER WRENCH.

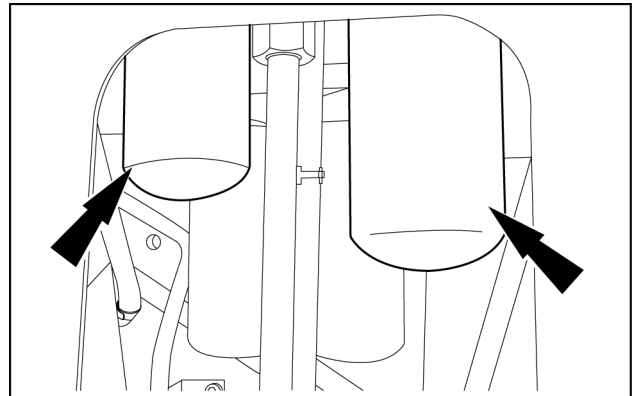

LEIL15WHL1790AB 5

Tire tread direction

When the tire is installed on the wheel make sure the tire tread is in the direction shown.

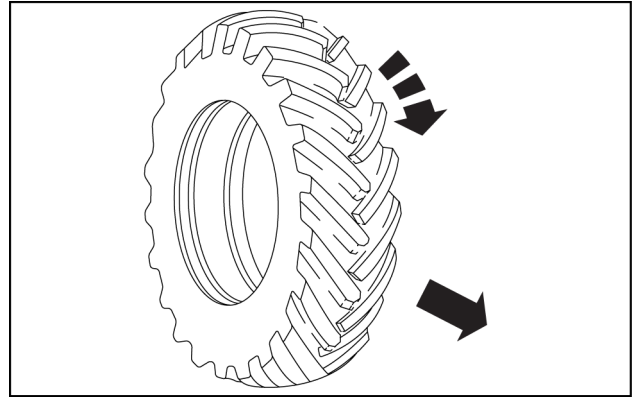

LEIL15WHL1842AB 2

Axle cooler filters

7. Axle cooler filters are located on the right-hand side of the machine beneath the steps. The shield can be removed for easier access if desired.

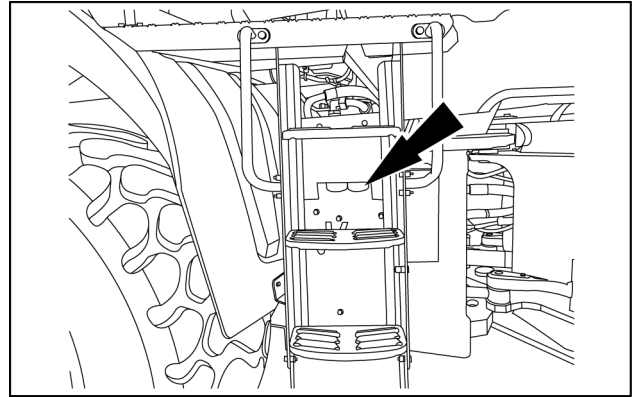

LEIL16WHL0673AB 4

8. Clean the area around the axle cooler filters. Remove filters by turning counterclockwise.
9. Apply a thin film of clean axle oil to the gasket of the new filter. Make certain proper contact is made with the base of the filter. Hand tighten then turn 1/2 to 3/4 turn more.

NOTE: do not use a filter wrench.

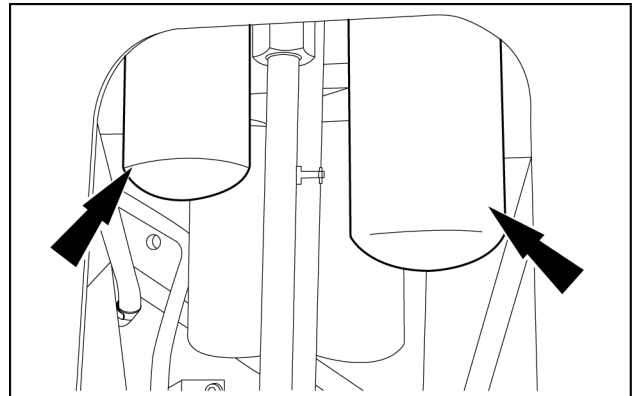

LEIL15WHL1790AB 5

1. Place the transport/service link into the locked position to stop unexpected articulation movements of the machine.
2. Clean the area around each fitting and grease.

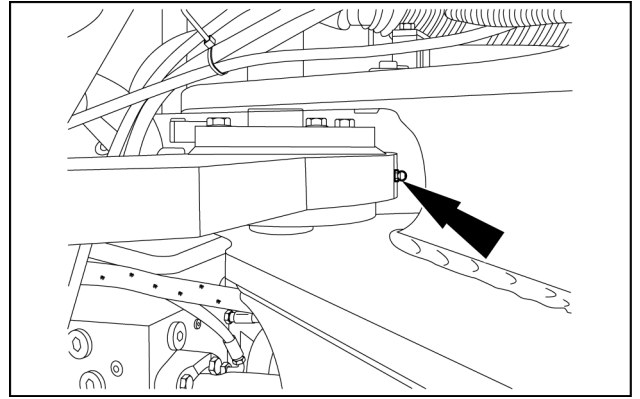

LEIL15WHL1794AB 2

Every 1500 hours

Transmission fluid and filter - Change

⚠ WARNING

Chemical hazard!

When handling fuel, lubricants, and other service chemicals, follow the manufacturer's instructions. Wear Personal Protective Equipment (PPE) as instructed. Do not smoke or use open flame. Collect fluids in proper containers. Obey all local and environmental regulations when disposing of chemicals.

Failure to comply could result in death or serious injury.

W0371A

Change the transmission fluid and filter every 1500 hours or more frequently when operating conditions are severe. Shorten service intervals in severe applications which involve running the torque converter under high load for more than **25 %** of operation time. Applications include basement digging or land clearing. Reduce intervals as well if using low viscosity oil.

Prior operation:

Keep all non-authorized personnel clear of the area. Park the machine on level ground, in neutral with the parking brake applied and the attachment lowered to the ground.

Oil Type	
Non- CASE AKCELA NEXPLORE™ FLUID (other brands)	CASE AKCELA NEXPLORE™ FLUID
Normal conditions - 1000	Normal conditions - 1500
Severe conditions - 500	Severe conditions - 1000

1021F Specifications (with filter change)	45.4 l (12.0 US gal)
1121F Specifications (with filter change)	45.4 l (12.0 US gal)

1. Lower bucket/attachment to the ground and lock the pilot control lock lever.
2. Put the transport/service link into the locked service position to avoid unexpected articulation, and stop the engine.
3. If it is necessary, remove the panel to easier access to the transmissions.

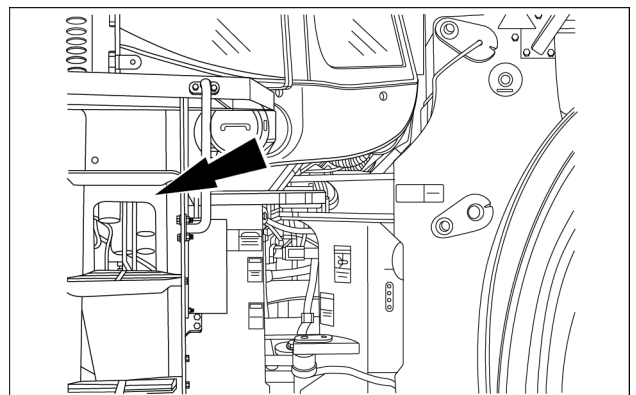

LEIL15WHL1789AA 1

Engine air filters - Replace

Check the engine air filters periodically for dirt and debris build up. Replace the engine primary and secondary air filter every 2000 hours or each year, whichever occurs first.

Prior operation:

Keep all non-authorized personnel clear of the area. Park the machine on level ground, in neutral with the parking brake applied and the attachment lowered to the ground.

NOTE: replace the primary element if the filter warning lamp on the instrument cluster illuminates or the audible alarm sounds. Should the caution warnings continue after replacing the primary filter, replace the secondary filter as well.

1. Lower bucket/attachment to the ground and install the transport/service link into the lock position.

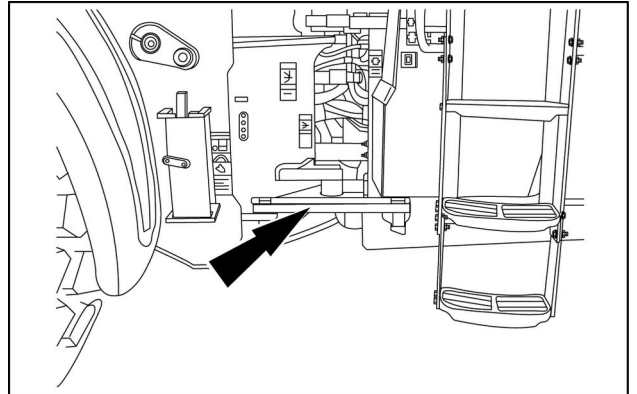

LEIL15WHL1782AA 1

2. Raise the engine hood. Use the handle indicated in figure to open the wide rear fender panel compartment (right-hand side of the machine).

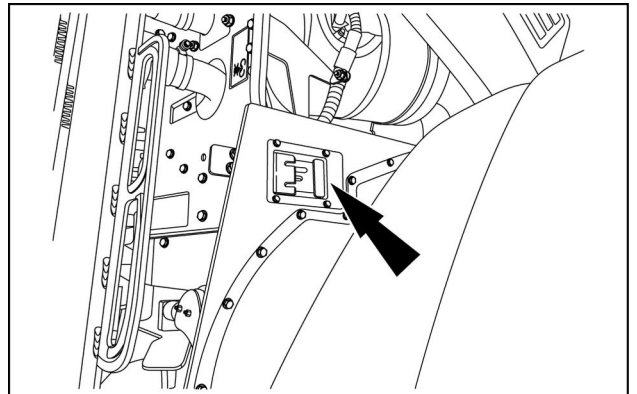

LEIL15WHL0775AA 2

3. Remove the side body panel (2) from the right-hand side of the engine compartment moving the latch (1).

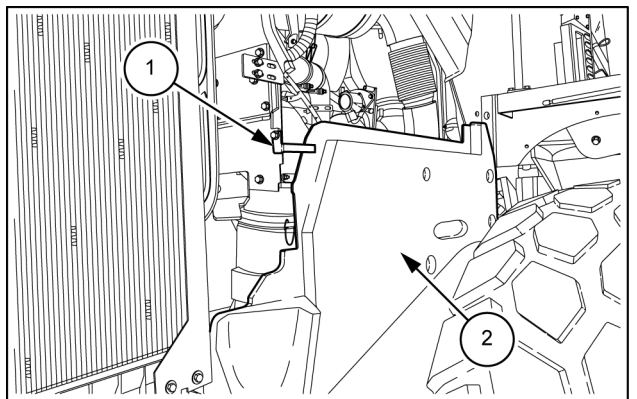

LEIL15WHL0703AB 3

Engine coolant - Change

⚠ WARNING

Burn hazard!

Hot coolant can spray and scald if you remove the radiator or deaeration tank cap while the system is hot. To remove the cap: allow the system to cool, turn the cap to the first notch, and wait for all pressure to release. Remove the cap only after all pressure has released.

Failure to comply could result in death or serious injury.

W0367A

⚠ WARNING

Rotating parts!

The engine is running. Keep clear of rotating fans and belts.

Failure to comply could result in death or serious injury.

W0275A

Drain, flush and replace the engine coolant every 4000 hours of operation or each year, whichever occurs first. Clean the system and replace the coolant if it becomes dirty or is rust colored.

Service specifications	
Type of coolant	CASE AKCELA ACTIFULL™ OT EXTENDED LIFE COOLANT
1021F Capacity	56.8 L (15.0 US gal)
1121F Capacity	56.8 L (15.0 US gal)

1. After the engine has cooled and the temperature of the coolant has reached a safe level, remove the cap.

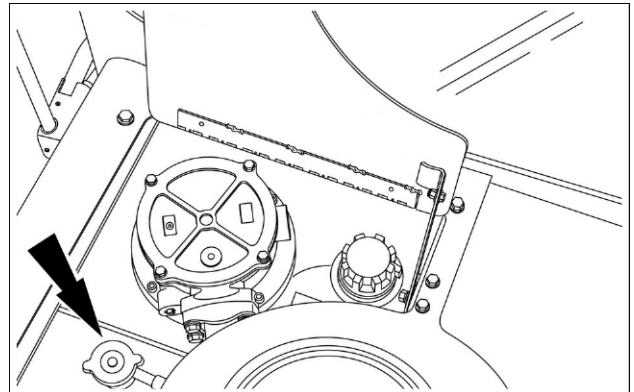

LEIL15WHL0718AB 1

2. With a suitable container of the proper capacity under the drain, open the cap by turning counterclockwise and drain the coolant from the system.
3. After all the coolant is drained, secure the drain cap.
4. Use a system cleaning product to clean and flush the system. Contact your Dealer for system cleaning products.
5. After the system has been cleaned and flushed following the cleaning product instructions, close and secure the drain valve.

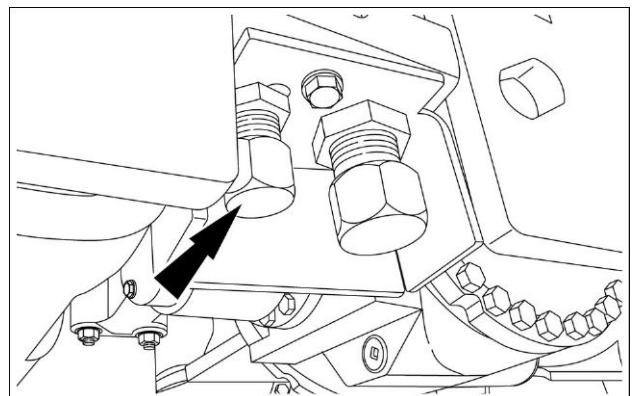

LEIL15WHL0719AB 2

Return-to-dig - Adjust

Z-Bar/XR Return-to-dig adjustment procedure

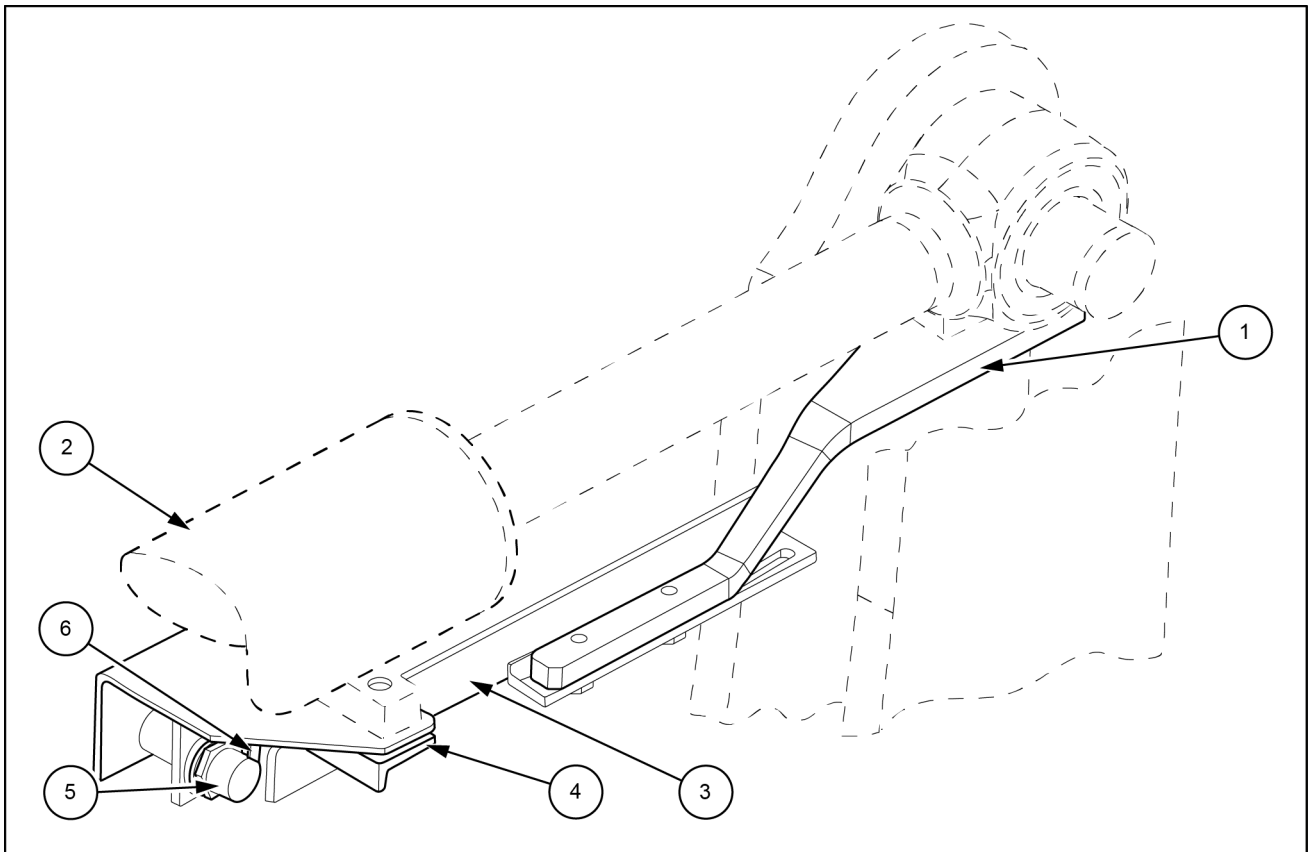

LEIL13WHL1148FB 1

- | | | |
|----------------------------|--------------------------------------|---------------------------|
| 1. Target mounting bracket | 3. Target bar | 5. Proximity switch |
| 2. Tilt cylinder | 4. Proximity switch mounting bracket | 6. Proximity switch guard |

NOTICE: before adjusting the return-to-dig, make sure that the target bar on the bucket linkage is not damaged. Slowly roll back and dump the bucket and make sure that the target bar stays the same distance from the switch. The switch mounting bracket protects the switch. Make sure the target bar cannot touch the switch when the bucket is dumped.

1. Park the machine on a level surface. Raise the lift arms until they are approximately horizontal. Fully dump the bucket. Lower the bucket until the bucket edge is on the ground.
2. Apply the parking brake and stop the engine.
3. Loosen the bolts holding the target mounting bracket (1) to the tilt cylinder eye. Align the target mounting bracket (1) parallel to the tilt cylinder (2). Tighten the bolts, refer to the illustration on this page.
4. Loosen the bolts holding the proximity switch mounting bracket (4) to the tilt cylinder (2). Position the proximity switch (5) parallel to the target bar (3) and tighten the bolts.

Windshield washer fluid level - Check







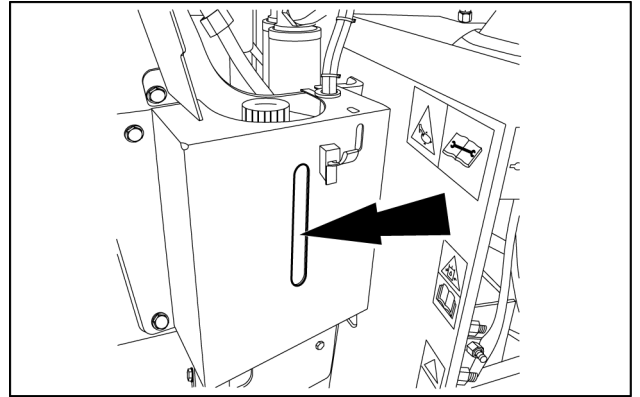





















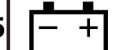











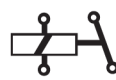























Check the windshield fluid level as required. The windshield washer reservoir is located on the right-hand side of the machine, under the steps.

If the windshield fluid level is too low, remove the filler cap and add a windshield solution as required. Reinstall the cap.

NOTE: use professional detergent fluid SC35 diluted with water in relation to the temperature of use. With a 50 – 50 solution of detergent and water the liquid does not freeze until **-10 °C (14 °F)**. Below this temperature, use pure detergent.



LEIL15WHL0685AB 1

ECC 						ECD 					
	K1		F1		7.5A		K1		F1		
	K2		F2		20A	HIGH		K2	F2		
	K3		F3		15A	LOW		K3	F3		
	K4		F4		10A		K4		F4		
	K5		F5		10A		K4		F5		
			F6		7.5A		K4		F6		
			F7		20A		K4		F7		
			F8		10A		K5		F8		
			F9		10A				F9		
			F10		7.5A				F10		
ECA 						ECB 					
F11		25A	F1		7.5A		K1		F1		10A
F12		10A	F2		10A				F2		10A
F13		10A	F3		7.5A	N	K2		F3		5A
F14		5A	F4		7.5A		K3		F4		5A
F15		7.5A	F5		7.5A		K4		F5		5A
F16		15A	F6		5A		K5		F6		5A
F17		7.5A	F7		7.5A				F7		5A
F18		15A	F8		5A				F8		5A
F19		5A	F9		5A				F9		10A
F20		20A	F10						F10		15A

code 47579458 A

LEIL13WHL0294HA 2

The fuse decal is located inside the access door.

8 - SPECIFICATIONS

General specification

1021F Model

1021F Engine Specifications

Model	FPT F2CFE614H, Tier 4b certified
Type	4-stroke, turbocharged, air-to-air cooled
Cylinders	6
Bore / Stroke	117 mm (4.61 in) x 135 mm (5.31 in)
Displacement	8.7 l (531 in³)
Fuel Injection	Electronic
Horsepower	
Maximum power (rated/peak)	
Gross	239 kW (320 Hp) @ 1800 RPM
Net	221 kW (296 Hp) @ 1800 RPM
Standard power (peak)	
Gross	222 kW (297 Hp) @ 1800 RPM
Net	204 kW (273 Hp) @ 1800 RPM
Economy power (peak)	
Gross	188 kW (253 Hp) @ 1400 RPM
Net	180 kW (241 Hp) @ 1400 RPM
Torque (maximum)	
Maximum power range	
Gross	1479 N·m (1091 lb ft) @ 1100 RPM
Net	1442 N·m (1064 lb ft) @ 1100 RPM
Standard power range	
Gross	1374 N·m (1013 lb ft) @ 1100 RPM
Net	1337 N·m (986 lb ft) @ 1100 RPM
Economy power range	
Gross	1285 N·m (948 lb ft) @ 1300 RPM
Net	1234 N·m (910 lb ft) @ 1300 RPM
Economy engine speeds	
Machine idled (alternate low idle)	670 - 730 RPM
Machine idled (cold weather alternate accelerated low idle)	1170 - 1230 RPM
Electrical	
Batteries	Two - 12 V
Alternator	120 A
Voltage	24 V

Dimensions specifications

The following specifications are common for all 1021F and 1121F model configurations:

Feature	1021F	1121F
Overall height (top of exhaust)	3545 mm (139.6 in)	3544 mm (139.5 in)
Rear axle oscillation total	26 °	26 °
Height to drawbar	1139 mm (44.8 in)	1134 mm (44.6 in)
Vertical wheel travel (trunnion fully oscillated)	488 mm (19.2 in)	499.5 mm (19.7 in)
Loader Speeds	1021F	1121F
Loaded raise (rollback @ ground)	6.2 s	6.49 s
Loaded dump (@ full height)	1.3 s	1.4 s
Empty power down	2.8 s	2.8 s
Empty float	2.6 s	2.6 s

8 - SPECIFICATIONS

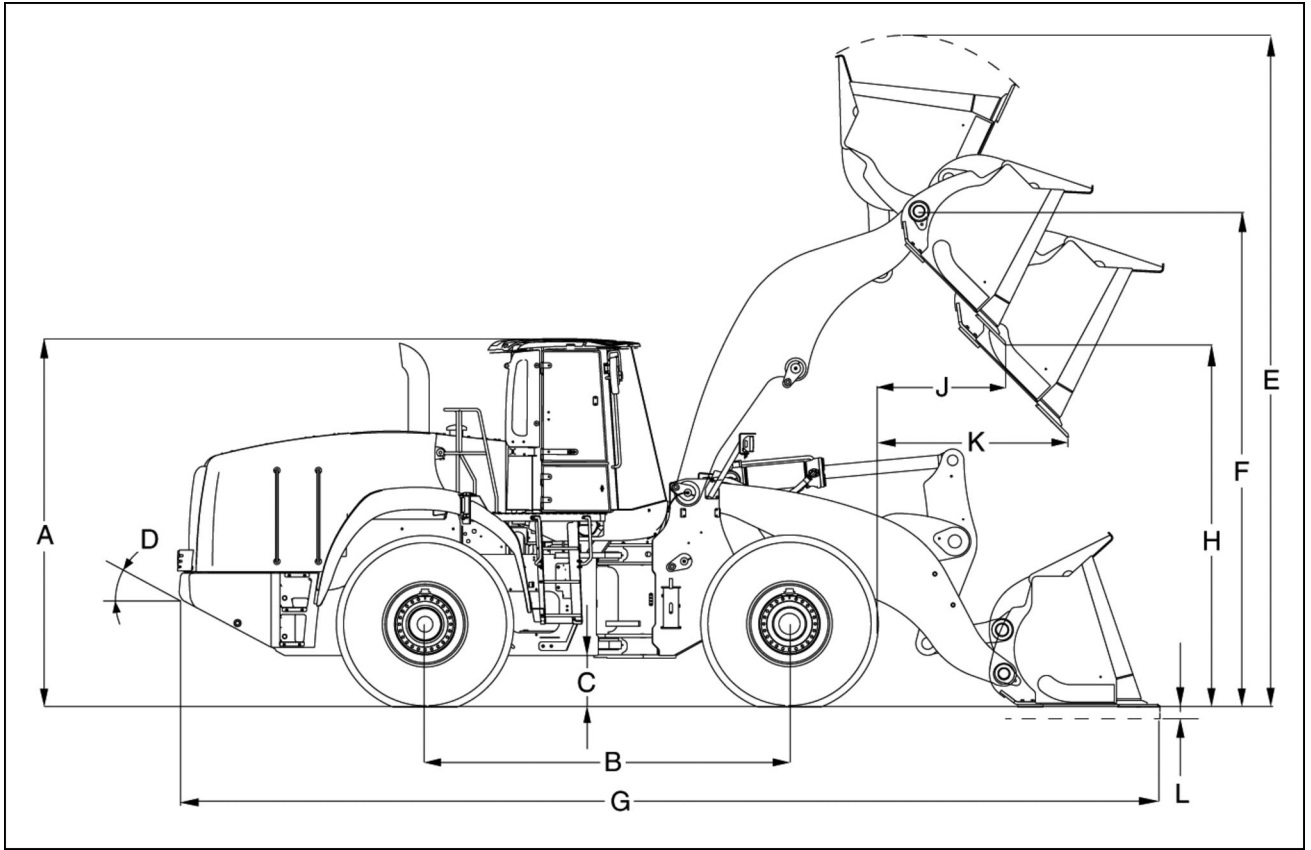

LEEN11T0120FA 10

1121F XR Specifications - 4.0 m³ (5.2 yd³) Bucket

	Bolt-on Edge Bucket	w/Teeth Bucket
ISO Bucket Specifications		
Struck	4.46 m ³ (4.53 yd ³)	3.31 m ³ (4.33 yd ³)
Heaped	4.01 m ³ (5.24 yd ³)	3.87 m ³ (5.06 yd ³)
Bucket width (maximum outer)	3195 mm (125.8 in)	3195 mm (125.8 in)
Dimensional Outline Specifications		
A (top of cab height)	3573 mm (140.6 in)	3573 mm (140.6 in)
B (wheelbase)	3550 mm (139.8 in)	3550 mm (139.8 in)
C (ground clearance)	509.4 mm (20.1 in)	509.4 mm (20.1 in)
D (rear angle of departure)	34 °	34 °
Overall width with bucket guard	2990 mm (117.7 in)	2990 mm (117.7 in)
Centerline tread width	2250 mm (88.6 in)	2250 mm (88.6 in)
Turning radius (outside of tires)	6372 mm (250.9 in)	6372 mm (250.9 in)
Turning angle from center	40 °	40 °
Total turning angle	80 °	80 °
E (fully raised with spillguard)	6377 mm (251.1 in)	6377 mm (251.1 in)
F (hinge pin - fully raised)	4860 mm (191.3 in)	4860 mm (191.3 in)
G (overall - bucket level on ground)	9374 mm (369.1 in)	9555 mm (376.2 in)
H (dump - fully raised, 45 ° dump)	3717 mm (146.3 in)	3600 mm (141.7 in)
J (reach - fully raised, 45 ° dump)	1200 mm (47.2 in)	1338 mm (52.7 in)
K (reach - 2.13 m (7.0 ft), 45 ° dump)	2335 mm (91.9 in)	2430 mm (95.7 in)
L (dig depth)	118 mm (4.7 in)	118 mm (4.7 in)
ISO Load Specifications		
Operating load	7882 kg (17378 lb)	7941 kg (17506 lb)
Tipping load		
Machine straight	18596 kg (40997 lb)	18732 kg (41298 lb)
40° turn	15765 kg (34756 lb)	15881 kg (35012 lb)

CLICK HERE TO **DOWNLOAD** THE COMPLETE MANUAL

- Thank you very much for reading the preview of the manual.
- You can download the complete manual from: www.heydownloads.com by clicking the link below



- Please note: If there is no response to CLICKING the link, please download this PDF first and then click on it.

CLICK HERE TO **DOWNLOAD** THE COMPLETE MANUAL