

# 8400 Series Tractors

*For models 8450 - 8460 - 8470 - 8480 Dyna VT*



CLICK HERE TO **DOWNLOAD** THE COMPLETE MANUAL

- Thank you very much for reading the preview of the manual.
- You can download the complete manual from: [www.heydownloads.com](http://www.heydownloads.com) by clicking the link below



- Please note: If there is no response to CLICKING the link, please download this PDF first and then click on it.

CLICK HERE TO **DOWNLOAD** THE COMPLETE MANUAL

# 1 . TRACTOR IDENTIFICATION

## 1.1 - SERIAL NUMBER

**IMPORTANT: PLEASE QUOTE THE SERIAL NUMBER OF YOUR TRACTOR IN ALL CORRESPONDENCE WITH YOUR DEALER OR AGENT.**

Homologation plate (according to country)



Z3A-1134-09-04

Fig. 1

Name plate with serial number (according to country).



Z3A-1132-09-04

Fig. 2

Front axle serial number



Z4A-1631-11-05

Fig. 3

"Sisu" engine serial number

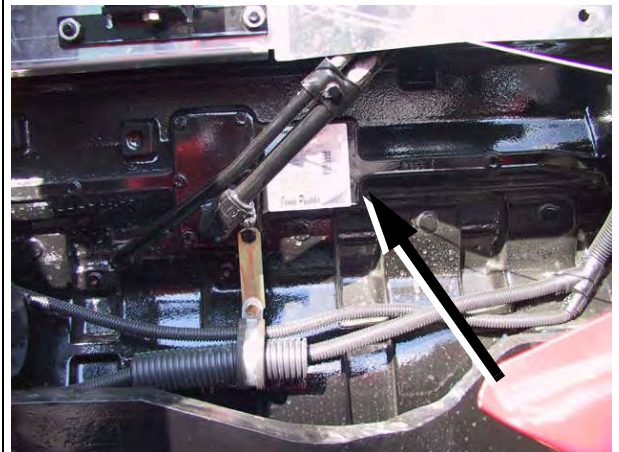

Z4A-1630-11-05

Fig. 4

Cab serial number



Z3A-702-07-04

Fig. 5

## 2 . INTRODUCTION - SAFETY INSTRUCTIONS AND WARRANTY

### 2.7 - SAFETY PROCEDURE

#### 2.7.1 - Ensuring proper operation

To operate an agricultural tractor properly, you must be a qualified and approved operator. To be qualified, you must understand the written instructions supplied in this operator instruction book, have training in how to operate the tractor and know the safety rules and regulations applicable to the job.

Some regulations specify that no one under the age of 16 may operate power machinery, for example. This includes tractors. It is your responsibility to know what these regulations are and to observe them in the operating area or situation.

These regulations include, but are not limited to, the following instructions for safe tractor operation.



**WARNING:** *The operator must not drink alcohol or take any medication that may affect his concentration or co-ordination. If taking medication, whether prescribed or not, the operator must seek medical advice with regard to his ability to operate machinery safely.*

#### 2.7.2 - Observe the following instructions

- **DO NOT ALLOW** children or unqualified persons to operate the tractor. Move unauthorised persons away from the work area.
- Always wear your seat belt securely fastened.
- Where possible, avoid operating the tractor near ditches, embankments and holes. Reduce speed when negotiating turns and slopes and on rough, slippery or muddy surfaces.
- Stay off slopes that are too steep for safe operation.
- Watch where you are going, especially at row ends, on roads and around trees.
- The instructor seat is only intended for short periods of use.
- Do not allow children to use the instructor seat.
- **DO NOT PERMIT** others to ride on the tractor or the implement unless an approved instructor seat is fitted.
- Only hitch attachments to the drawbar and recommended hitch points and never above the centre line of the rear axle.
- Operate the tractor smoothly — avoid jerky turns, starts or stops. When the tractor is stopped, apply the hand brake securely. Lower the implement and remove the ignition key.
- **DO NOT MODIFY OR REMOVE** any part of the equipment and **DO NOT USE** attachments unless they are properly adapted to suit your tractor.

### 2.8 - PROTECTION

#### 2.8.1 - Cab

The ROPS (Roll Over Protective Structure) has been designed for this tractor series and meets all legal safety and sound requirements.

The ROPS conforms to the various international safety standards. The ROPS must **NEVER** be drilled or modified to enable installation of accessories or implements. Welding components is **NOT PERMITTED. DO NOT ATTACH** chains or ropes to the main frame of the ROPS for pulling purposes.

If additional controls or displays must be added to the operator's area, contact your AGCO dealer for information.

The ROPS and the seat belt are effective in reducing injuries during overturn accidents. Wearing the seat belt is an important part of this protection.

#### 2.8.2 - Roll Over Protection Structure (ROPS)

A Roll Over Protection Structure (ROPS) and seat belt are fitted to tractors without a cab during manufacture. If the ROPS has been removed by the original owner or subsequently, it is recommended to fit the tractor with a new one, in addition to a seat belt. ROPS are effective in reducing injuries when accidents occur and the tractor overturns. If the tractor overturns and is not fitted with a ROPS, serious injury or death may result (Fig. 1).

If the tractor is fitted with a folding ROPS, DO NOT wear the seat belt when the ROPS is in folded position.



Fig. 1

## 2 . INTRODUCTION - SAFETY INSTRUCTIONS AND WARRANTY

- Operate the tractor using tyres that are of a suitable width for the particular task you are performing. To adjust tyre width, see the Servicing and Adjustments chapter.
- Reduce your speed when operating over rough or slippery ground and when foliage restricts your view.
- **DO NOT** make sharp turns at high speed.

### 2.12.9 - Implements and attachments



**WARNING:** A front-end loader (bucket or fork) must be fitted with a suitable holding device to prevent the load (bales, fence posts, rolls of fence, wire etc.) from rolling down the lift arms into the operator cab and crushing the operator when the loader is raised. Inadequately secured objects could also fall and injure bystanders.

- Implements fitted to the three-point hitch or to the side of the machine make a much larger arc when turning than trailed attachments. Ensure there is sufficient clearance for turning. Use only AGCO-approved attachments.
- When using attachments or implements with the tractor, be sure to read and understand the instructions in the operator instruction book for that attachment or implement and follow the safety instructions. Use only AGCO-approved attachments and implements.
- **DO NOT** overload accessories or trailed attachments. Use appropriate counterweights to maintain tractor stability. Only hitch loads to the drawbar.
- A safety chain (1) will help control a trailed attachment should it be accidentally separated from the drawbar during transportation. Using the appropriate adaptor parts, attach the chain to the tractor's drawbar anchor or any other specified anchor point. Leave only enough slack in the chain to permit turning. Contact your AGCO Dealer to obtain a chain of equal or greater strength than the weight of the trailed machine (Fig. 18).
- Ensure that all trailed implements are fitted with a safety chain linking the tractor and the implement, if required by law (Fig. 18).
- Pull only from drawbars suitable for traction. Towing or attaching to other locations may cause the tractor to overturn (Fig. 19).

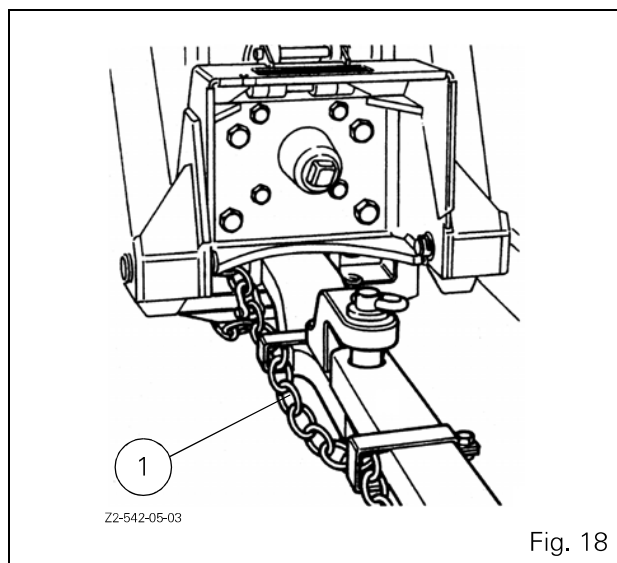

Fig. 18

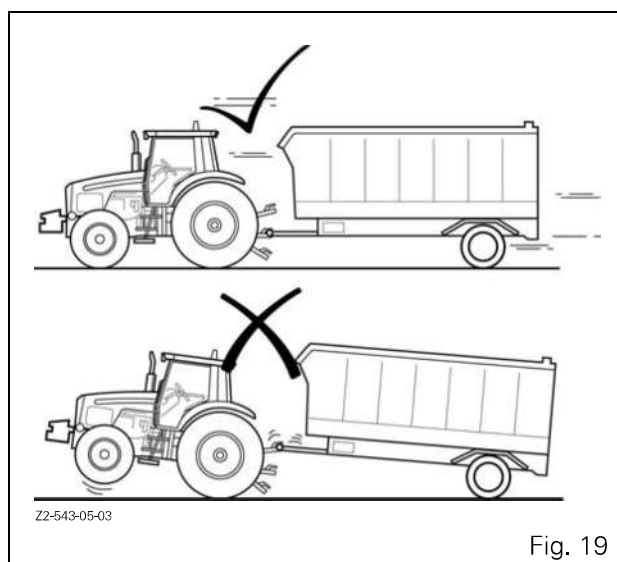
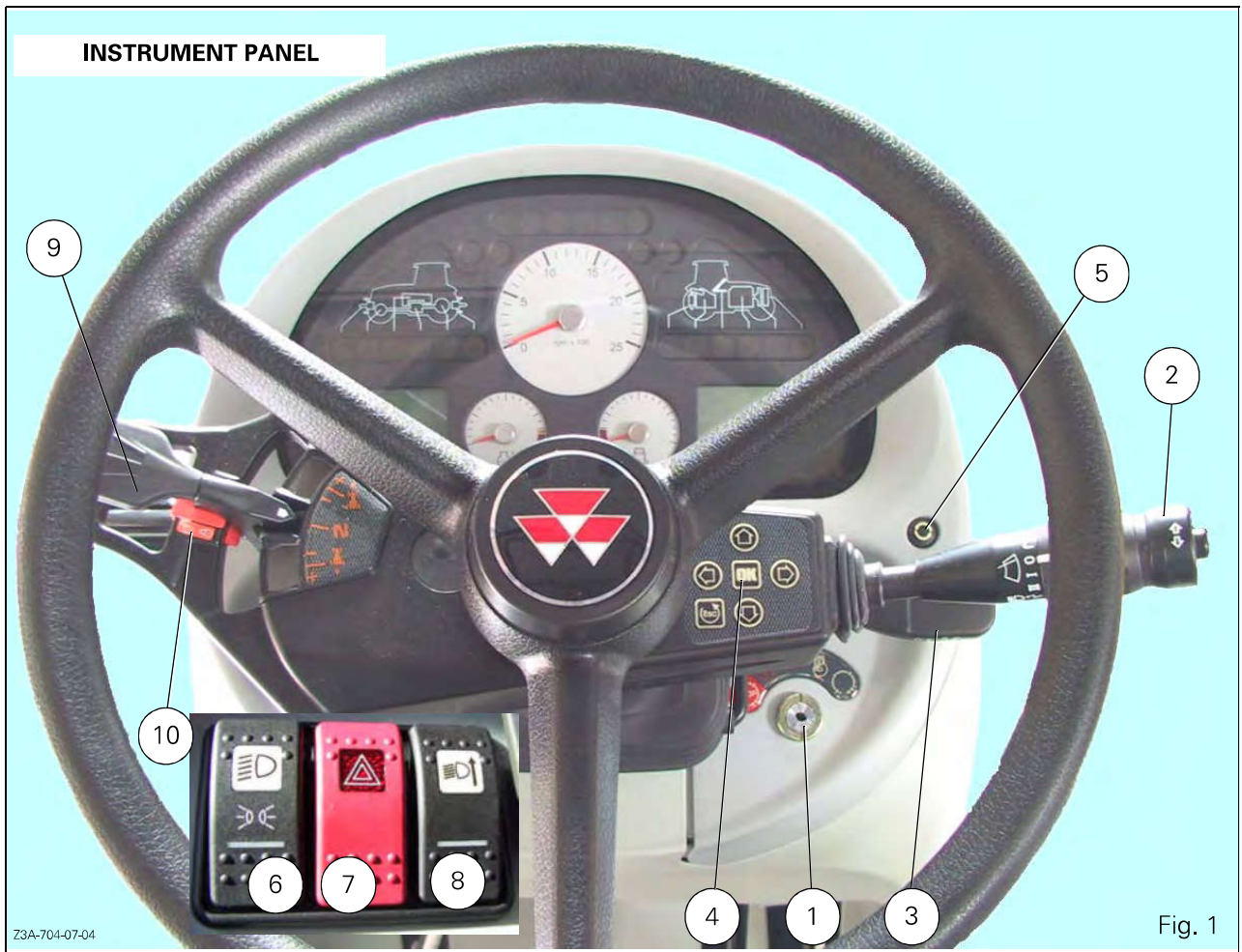

Fig. 19



#### 3.1 - INSTRUMENT PANEL (FIG. 1)

1. Start switch (see detail in Fig. 3).
2. Control unit (see detail in Fig. 2).  
This assembly comprises the direction indicator, windscreen wiper, front and rear windscreen washer and horn.
3. Steering wheel adjustment (see detail in Fig. 26).
4. DOT MATRIX controls (see details in Fig. 11).
5. Parameter display selector switch (22 Fig. 4).
6. Main lighting switch.
7. Hazard warning lights and control switch.
8. Main beams on hand rails control switch (optional).
9. Direction of travel and reverse shuttle control lever.
10. Electro-mechanical brake control (ParkLock option).

Legend:

1. Windscreen wiper:
  - 0. Stop
  - J. Intermittent
  - I. Speed 1
  - II. Speed 2
2. Left-hand indicator
3. Right-hand indicator
4. Horn
5. Headlights flash
6. Headlights
7. Front and rear windscreen washer

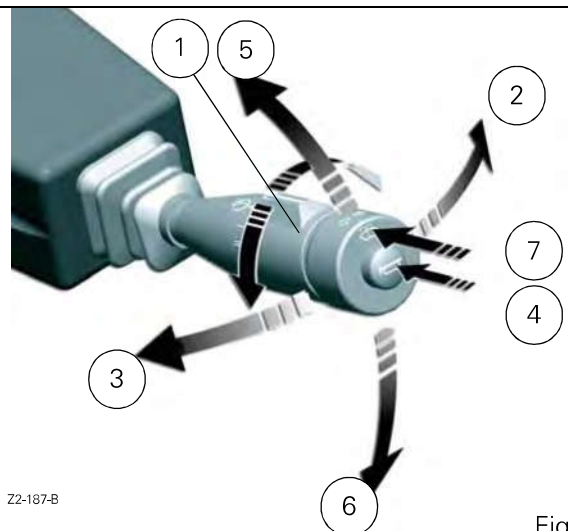

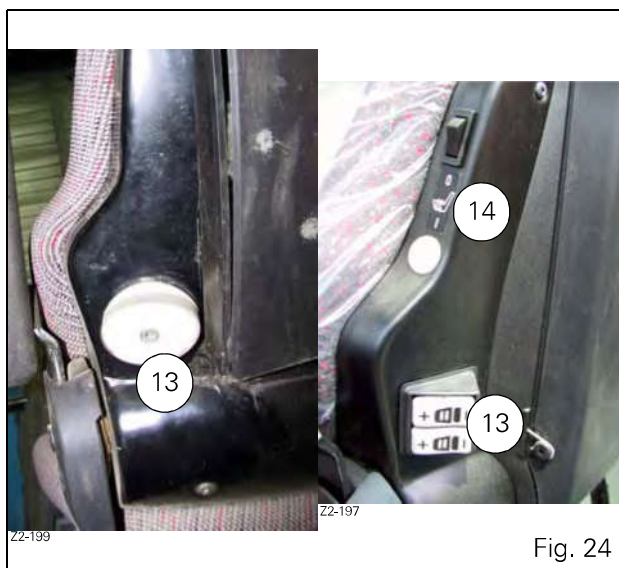

Fig. 24

#### 3.8.1 - Adjusting the multifunction armrest position

The length and height of the multifunction armrest located on the right-hand side of the seat can be adjusted after loosening the thumb wheels on its underside (ref. 1 Fig. 25).

Move the armrest to the required positions and firmly tighten the thumb wheels.

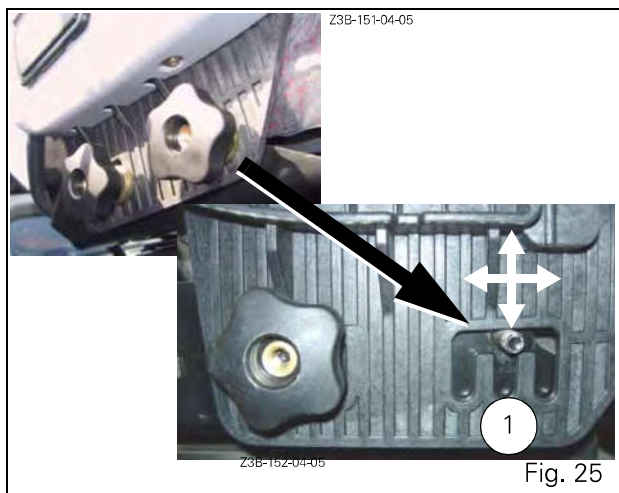

Fig. 25

#### 3.9 - STEERING WHEEL

(Fig. 26)

The steering wheel tilt and height may be adjusted (except on platform models). Both adjustments are made using a single lever.

1. Height adjustment
2. Angle adjustment











**DANGER:** The tractor must be stopped when carrying out steering wheel adjustments.

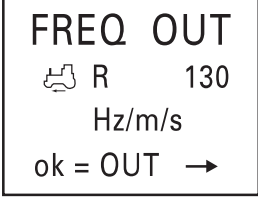

Fig. 26

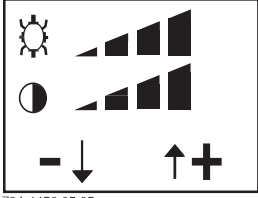
## CONTENTS

<b>4.1 - RUNNING-IN</b> .....	<b>4.5</b>
4.1.1 The following precautions should be taken during the running-in period .....	4.5
<b>4.2 - START-UP</b> .....	<b>4.5</b>
4.2.1 Starting the engine .....	4.5
4.2.2 Cold weather starting .....	4.5
<b>4.3 - STOPPING THE ENGINE</b> .....	<b>4.7</b>
<b>4.4 - DRIVING THE TRACTOR</b> .....	<b>4.7</b>
4.4.1 Foot throttle. ....	4.7
4.4.2 Reverse shuttle control .....	4.7
4.4.3 Brakes .....	4.7
4.4.4 "ParkLock" electro-mechanically controlled brake (optional) .....	4.8
4.4.5 Selecting a suitable transmission ratio .....	4.8
4.4.6 Preselecting A/B engine speeds .....	4.8
4.4.7 Using the DOT MATRIX screen .....	4.9
<b>4.5 - DYNA-VT TRANSMISSION</b> .....	<b>4.14</b>
4.5.1 General .....	4.14
4.5.2 Operation .....	4.14
4.5.3 Different control modes .....	4.15
4.5.4 Setting forward speed .....	4.16
4.5.5 Engine underspeed supervisor .....	4.17
4.5.6 Clutch-coupler function .....	4.18
4.5.7 Setting restart speeds for shifting .....	4.19
4.5.8 Selecting Hare or Tortoise range .....	4.19
4.5.9 SV1 and SV2 speed regulators .....	4.19
<b>4.6 - DIFFERENTIAL LOCK</b> .....	<b>4.20</b>
<b>4.7 - FOUR-WHEEL DRIVE FRONT AXLE</b> .....	<b>4.21</b>
4.7.1 Suspended front axle .....	4.21
<b>4.8 - SUSPENDED CAB</b> .....	<b>4.22</b>
<b>4.9 - STEERING</b> .....	<b>4.22</b>
<b>4.10 - WHEEL SLIP CONTROL</b> .....	<b>4.22</b>
<b>4.11 - POWER TAKE-OFF</b> .....	<b>4.23</b>
4.11.1 Front power take-off .....	4.23
4.11.2 Rear power take-off (PTO) .....	4.23
4.11.3 External PTO stop button .....	4.24
4.11.4 Interchangeable shaft end-fitting (flanged shaft) .....	4.25
<b>4.12 - ELECTRONIC LINKAGE</b> .....	<b>4.26</b>
4.12.1 Attaching an implement from the operator's seat .....	4.27
4.12.2 Lowering .....	4.27
4.12.3 Lifting .....	4.27
4.12.4 Depth control .....	4.27
4.12.5 Attaching an implement using external controls .....	4.28
4.12.6 Transport .....	4.29
4.12.7 Active transport control system .....	4.29
4.12.8 Quick soil engagement .....	4.29
4.12.9 Operation when working .....	4.29
4.12.10 Operation at headlands .....	4.29
<b>4.13 - AUXILIARY HYDRAULICS</b> .....	<b>4.30</b>
4.13.1 General .....	4.30
4.13.2 Hose connection .....	4.31

Screen	Access	Function
 <p>MA-11-06146A</p>	 Used to change the reference speed (next screen).  To exit the Frequency menu.	<p><b>Forward speed output settings screen (models fitted with electronic injection)</b>            Used to adjust the current speed reference frequency (36 to 144) (consult your dealer for details on connection and value settings).</p>
 <p>MA-11-06147A</p>	 Used to return to the PTO FREQ OUT screen.  To exit the Frequency menu.	<p><b>Current forward speed output settings screen (models fitted with electronic injection and radar)</b>            Used to adjust the current speed reference frequency (36 to 144) (consult your dealer for details on connection and value settings).</p>
 <p>Z3A-1450-05-05</p>	 To display from the previous screen.   To increase or decrease the value.	<p><b>Brightness/contrast screen</b>            Used to adjust screen brightness and contrast.</p>

**IMPORTANT:** When stopping the engine, all DOT MATRIX functions except the coupler function (CLUTCH) shift to OFF position.

CLICK HERE TO **DOWNLOAD** THE COMPLETE MANUAL

- Thank you very much for reading the preview of the manual.
- You can download the complete manual from: [www.heydownloads.com](http://www.heydownloads.com) by clicking the link below



- Please note: If there is no response to CLICKING the link, please download this PDF first and then click on it.

CLICK HERE TO **DOWNLOAD** THE COMPLETE MANUAL

## 4.11 - POWER TAKE-OFF



**WARNING:** Always disengage the PTO before hitching, unhitching or adjusting an implement.

Take all necessary safety precautions for any operation involving implements that are driven by the PTO.



**DANGER:** Power take-off

Never go beyond the universal joint line.

Do not use the tractor or trailer drawbars as a step.

Never use the universal joint as a step.

Never wear loose-fitting clothes.

Remain at a safe distance from the universal joint.

### 4.11.1 - Front power take-off

The front PTO is controlled by the switch (Fig. 34).

To engage the PTO, slide the red safety slider, as indicated by the arrow, while pressing the switch, as shown by ref. D, to unlock it; the indicator light ref. 1 lights up on the instrument panel.

Press the switch, as shown by ref. E to stop the PTO; in this position the switch prevents accidental engagement.



### 4.11.2 - Rear power take-off (PTO)

The PTO is operated independently from the transmission. 540 rpm, 540E rpm or 1000 rpm speeds can be obtained by selecting the appropriate speed with the buttons ref. 3 (Fig. 35). The relevant display appears on the digital display and the indicator light ref 6 flashes on the instrument panel.

**IMPORTANT:** Engage the PTO at low engine speed to protect the clutch and transmission.

Button "N" disengages the power take-off if it is activated.

PTO speed selected	Display	Maximum engine speed
540 rpm	540	2090 rpm
540E rpm	ECO	1600 rpm
1000 rpm	1000	2030 rpm

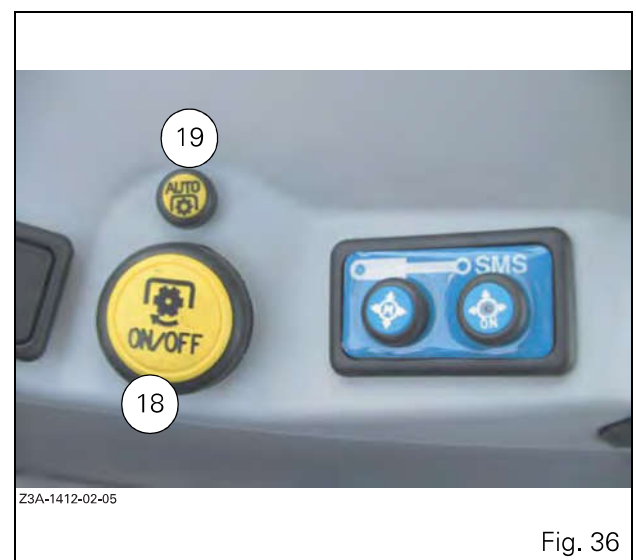
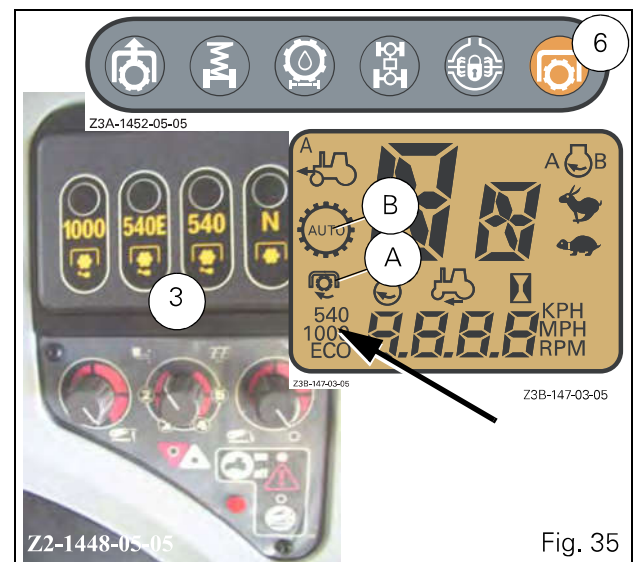

- Floating position (example: Fig. 58)

To activate the floating position, push the lever to its maximum position (E), then release it. The lever returns to its initial position, while the spool valve is in floating position.

To deactivate the floating position, move the lever to any position. The spool valve switches to neutral position.

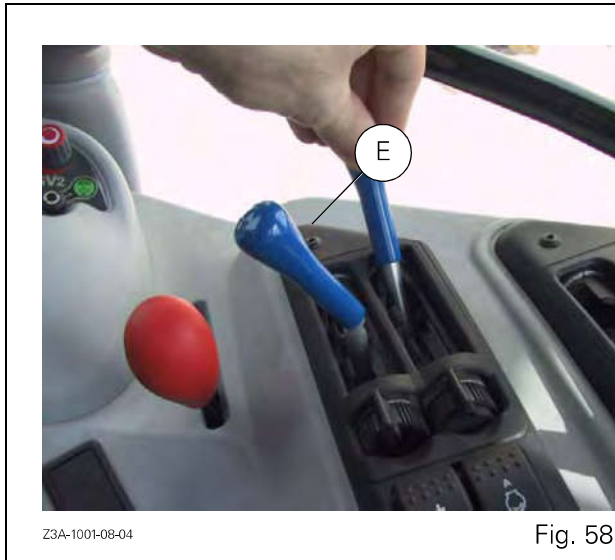

**NOTE:** If the tractor is fitted with Datatronic 3, ensure that the "Floating" function is available for each spool valve (Fig. 59). Refer to the specific documentation for details on activating this function.

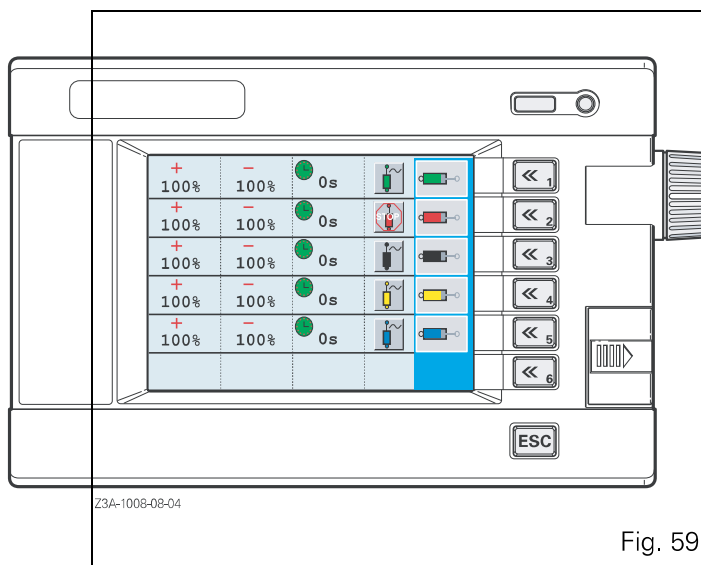

Floating position unavailable



Floating position available

## 4.13.5 - "SMS" joystick control

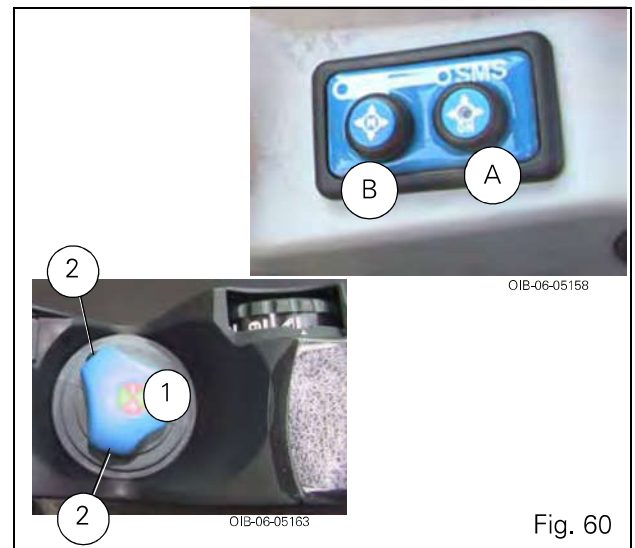

1. 4-function control joystick (separate or combined)  
Description (Fig. 61):  
A - Lift  
B - Lower  
C - Dump (bucket loader)  
D - Fill (bucket)
2. Additional function control buttons (2, Fig. 60), e.g. loader (open/close jaws). To use this function, press and hold the button and move the joystick towards C or D.

Operation (Fig. 60):

When starting the engine, the joystick is unavailable and the red indicator light is lit.

When Datatronic is installed, the corresponding settings in the active window are locked (padlock visible on the half-screens).

1. Press button A (Fig. 60) to activate the joystick; the red indicator light goes out and the padlock icon disappears from the half-screens; adjustment via Datatronic 3 is now possible.

2. Move and hold the joystick in the desired direction to obtain the required movement; the movement stops as soon as the joystick is released.

3. When the joystick is moved to its limit of travel, beyond its locked B1/C1 floating position, and then released immediately, the movement is automated, and when in OFF position the "~" symbol is displayed on the lower screen.

**NOTE:** The speed and duration of the movements depend on the parameters previously recorded on the Datatronic 3. To cancel the values, press the button (B Fig. 60) for approximately 5 seconds (default values 100%).

*Chapter 5*

***SERVICING AND ADJUSTMENTS***

## 5 . SERVICING AND ADJUSTMENTS

5. Lift ram head (2 x 1 grease nipple).

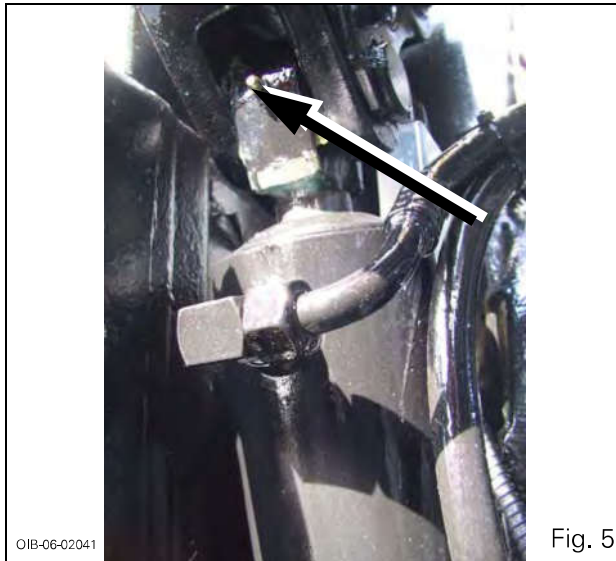

6. "ParkLock" shaft (2 grease nipples).

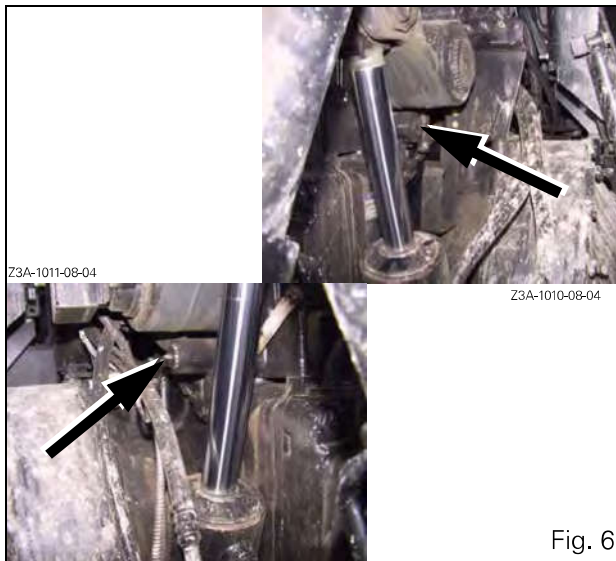

7. Front/rear bearings on 4WD fixed front axle (2 grease nipples).

*NOTE: Lift the front end of the tractor to assist lubrication of the front axle.*

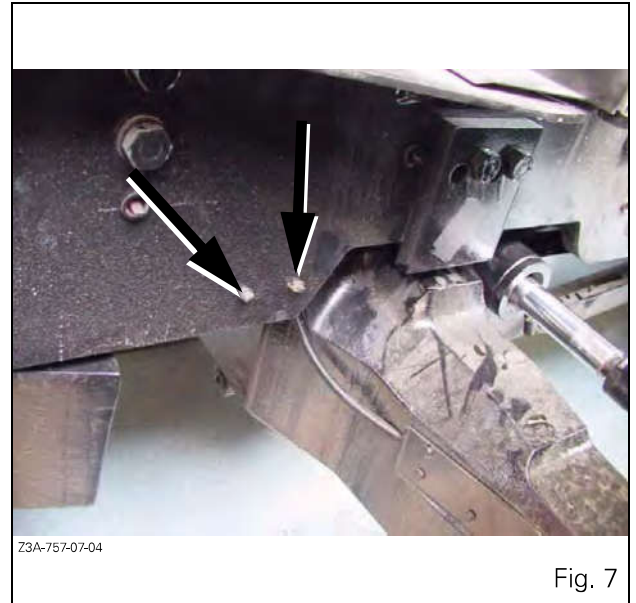

8. Lower cylinder pivot on 4WD suspended front axle (1 grease nipple).

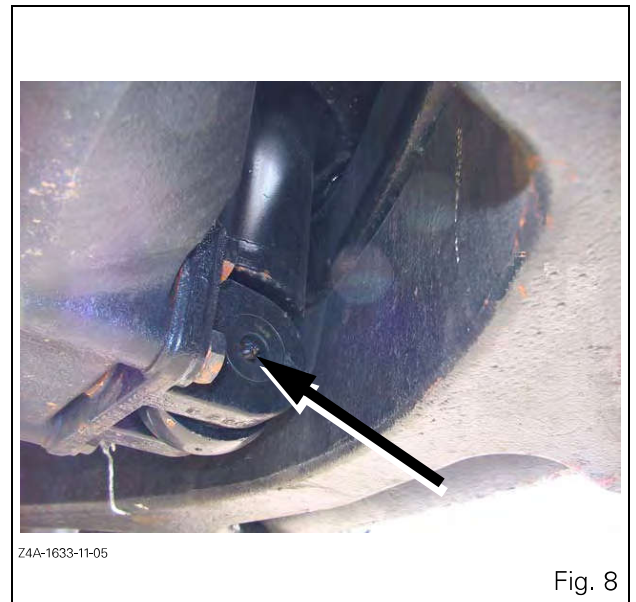

### 5.11.2 - Auxiliary hydraulics

As soon as the instrument panel is switched on, the DOT MATRIX screen displays the auxiliary hydraulic oil level as a percentage (Fig. 38).

**IMPORTANT:** Stand the tractor on level ground, with the front axle suspension disengaged.

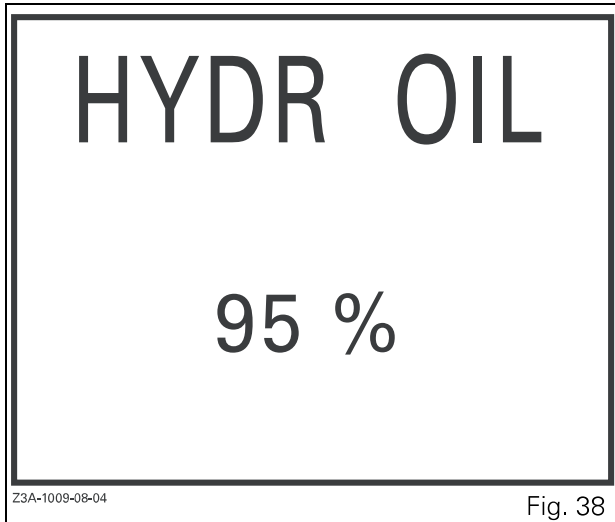

- 100%: tank full
- 50%: warning threshold

When the auxiliary oil tank filling level drops below 50%, it is displayed as a priority on the DOT MATRIX screen.

**IMPORTANT:** When the oil level drops below 50%, top up as soon as possible.

#### 5.11.2.1 - Draining the auxiliary hydraulics

**IMPORTANT:** Stand the tractor on level ground, with the front axle suspension disengaged.

#### Every 1200 hours

To carry out draining, the oil must be hot and the linkage must be in lowered position with all rams retracted.

- Unscrew the drain plug (ref. 4 and 5, Fig. 39).

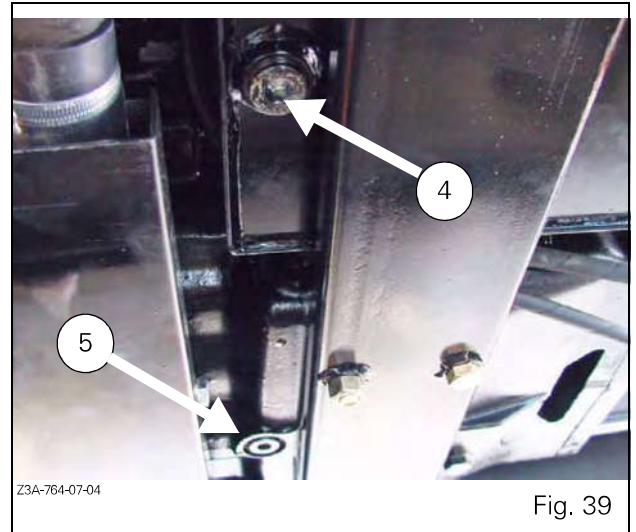

- Fill the tank through the filler plug (ref. 6, Fig. 40).

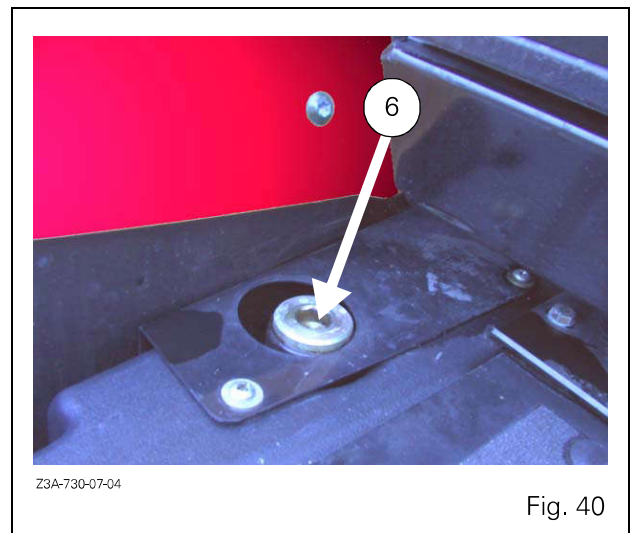

- Replace the breather plug every 1200 hours (1 Fig. 41).
- If the hydraulic system is polluted, change the 300-micron steering suction strainer (2 Fig. 41) and the 300-micron LS pump suction strainer (3 Fig. 42).

**NOTE:** The tank must be disassembled for the latter step of the operation (consult your dealer or agent).

## 5 . SERVICING AND ADJUSTMENTS

### 5.18.9 - Pressure under load (bar)

**Check the tyre pressures** every 100 hours. Tyre pressures vary according to make, load and speed as well as to the type of work being carried out.

Refer to the inflation tables issued by the tyre manufacturers.

**IMPORTANT:** *The relationship between the sizes of the front and rear tyres on 4-wheel drive tractors must be maintained. Compatible options are given in chapter 6.*

Dimensions		Pressure under load (bar)					
		Kleber Super 8 - 9		Michelin		Goodyear	
		Max.	Min.	Max.	Min.	Max.	Min.
Front	16.9R30	2.1	0.6	1.9	0.4	1.6	0.6
	320-85R34	-	-	-	-	-	-
	480-70R30	2.1	0.4	1.9	0.4	2.4	0.6
	540-65R30	2.4	0.4	2.4	0.4	2	0.6
	600-65-R28	2.1	0.4	1.9	0.4	2	0.6
Rear	480-80R-46	-	-	2.7	0.4	-	-
	650-75R38	2.4	0.4	-	-	-	-
	650-85R38	2.4	0.4	-	-	3	0.6
	710-70R38	2.1	0.4	1.9	0.4	3	0.6

### 5.19 - WHEELS

**Check the tightness of wheel nuts** every day. Tighten all wheel nuts until the torque (dry nuts) is the same as that specified (see Specifications).

### 5.20 - ADJUSTING TRACK WIDTHS

#### 5.20.1 - Front track width

##### 5.20.1.1 - 4-wheel drive

The track widths available depend on the type of axle beam and the tyre dimensions.

**NOTE:** *If the wheels are reversed they must be transferred to the opposite side of the tractor.*

When refitting, tighten the nuts progressively to the correct torques. See tightening torque table (chapter 6).

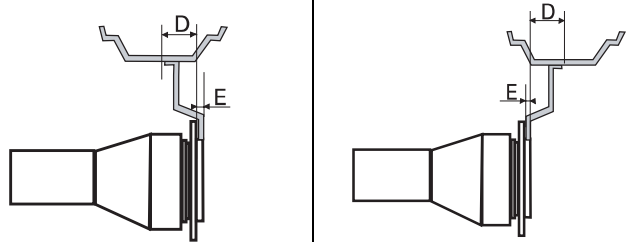
TABLE OF FRONT TRACK WIDTH VALUES in mm				
Transmission type - Front axle				
		Between flanges	Disc facing inwards	Disc facing outwards
		D = wheel offset 75 mm - E = wheel disc thickness 12 mm.		
8450/60	750/601	1892	1842	1996
8470/80	760/601	1892	1692	2116

- remove the 2 screws that hold the fuse (9, Fig. 77) in place.

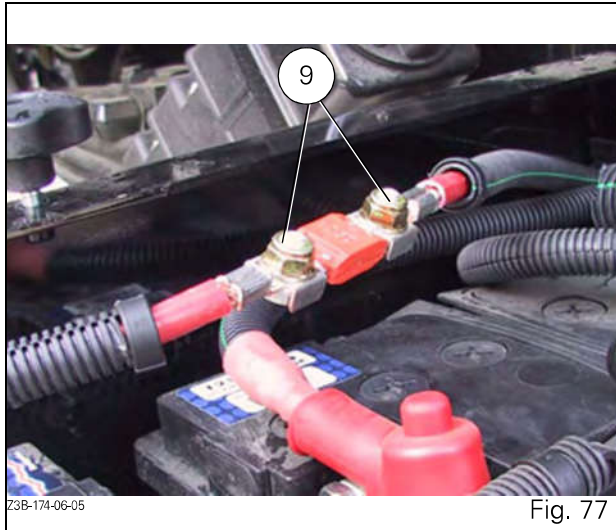

**IMPORTANT:** Always replace the fuse with another fuse of the same capacity.

### 5.22.1 - Battery isolator

(Available as an option)

This safety device is designed to cut the battery power supply in an emergency or during extended storage.



**In an emergency:**

To cut the power supply, **turn the handle** on the battery isolator (Fig. 78) **to the OFF position** (anti-clockwise) (Fig. 79).

**Extended storage:**

If the tractor is to remain out of service for an extended period, it is advisable to isolate the circuit to prevent the batteries going flat.

To do so, turn the handle anti-clockwise and pull it towards you to remove it from its housing, then remove the fuse (1 Fig. 78).

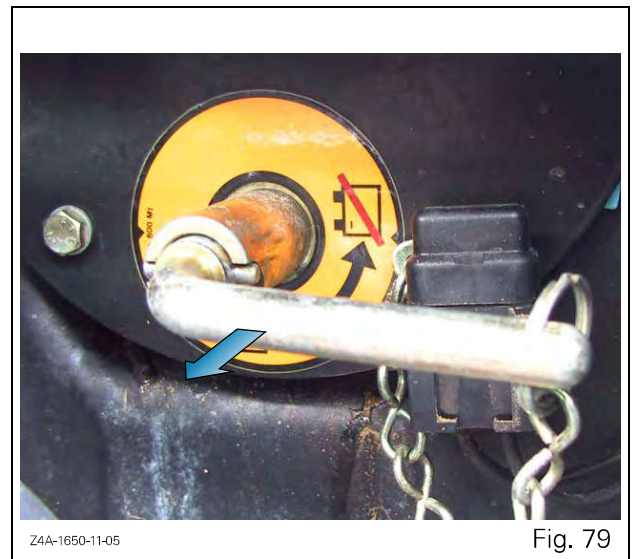
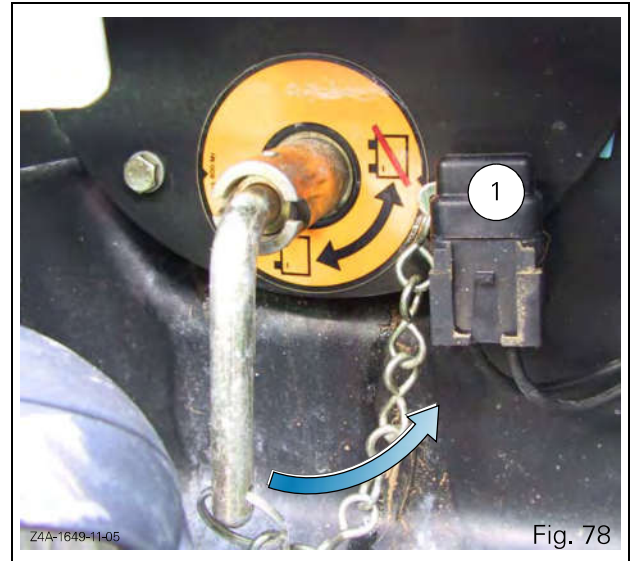

**NOTE:** A 3 A fuse located near the battery isolator switch protects the radio and lighting module (Fig. 78).

To replace this fuse, you must:

- remove the fuse cover (1 Fig. 78) to access the fuse

**IMPORTANT:** Always replace the fuse with another fuse of the same capacity.

- carry out the same operations in reverse order to reassemble

**IMPORTANT:** Before turning the ignition key, ensure the battery isolator switch is closed (Fig. 78); otherwise the 3 A fuse may blow.

### 6.4 - COOLING

Method:	Centrifugal pump and pressurised radiator. Thermostat regulation. Opening temperature (start/full): 83°C/93°C (181.4/199.4°F). Thermostat control.
Fan:	Vistronic or viscostatic clutch fan, according to model. Belt-driven water pump.
Belt:	Fan: Poly-V ribbed belt. Air conditioning compressor: Poly-V ribbed belt.

### 6.5 - TRANSMISSION

Transmission:	
• Dyna VT transmission:	- Continuous speed variation from 0 to 50 kph in forward travel (depending on country) and from 0 to 38 kph in reverse travel.
• Filtration:	- 1 150-micron suction strainer, located to the right of the centre housing. - External main high-pressure 10-micron filter, to the right of the centre housing.
• Crownwheel and pinion/ differential reduction ratios:	- normal assembly (HA 200): 3.58 - reinforced assembly (HA 260): 3.81

### 6.6 - FINAL DRIVES

Drives:	Epicyclic, located in the rear axle housings.
Reduction ratio:	8450/8460 normal assembly (HA 200): 8.25 8470/8480 reinforced assembly (HA 260): 9.2

### 6.7 - REAR POWER TAKE-OFF (PTO)

Flanged shaft:	540/1000 rpm at engine 2000 rpm (Ø35 mm 6 or 21 splines) (Ø44.5 mm 20 splines). 540/540E/1000 rpm at engine 2000 rpm (Ø35 mm 6, 20 or 21 splines) (Ø44.5 mm 20 splines).
Control:	Switches in cab, with PTO brake. With or without PTO stop button on rear fenders.

### 6.8 - FOUR-WHEEL DRIVE FRONT AXLE

Clutch mechanism:	Electrohydraulic, electrically controlled by a button on the console in the cab.
Differential lock:	Multidisc differential lock with electrohydraulic control.
Gear reduction ratios:	8450/8460: 750/601 (750/522): 15.75 8470/8480: 760/601 (760/521): 16.8

### 7.1 - ACCESSORIES AND OPTIONS

- Rear wheel weights: 1 to 4 external wheel weights.
- Front weights: 10/12 or 14 x 55 kg.
- Centre weight: 800 kg.

The centre weight is not compatible with the front PTO.

**IMPORTANT:** *Removal is not easy and the weight must remain fitted.*

- Front linkage: 3.5 T or 5 T (chapter 7.2).
- Rear linkage (chapter 4).
- Rear windscreen wiper and washer.
- Instructor seat.
- Front fenders.
- PTO — different types (chapter 4).
- Radio fittings (loudspeakers, aerial and wiring).
- Radio.
- Seat belt
- Battery circuit breaker.
- "Datatronic 3" computer.
- FRONT DUAL CONTROL
- REAR DUAL CONTROL
- Trailed implement control (TIC)
- Front PTO (section 7.3).

CLICK HERE TO **DOWNLOAD** THE COMPLETE MANUAL

- Thank you very much for reading the preview of the manual.
- You can download the complete manual from: [www.heydownloads.com](http://www.heydownloads.com) by clicking the link below



- Please note: If there is no response to CLICKING the link, please download this PDF first and then click on it.

CLICK HERE TO **DOWNLOAD** THE COMPLETE MANUAL