

en

Operator's manual

Hydraulic excavator

Document ID

	ORIGINAL OPERATOR'S MANUAL
Order number:	11829208
Issued:	2019-10-18
Version:	01
Author:	LFR / Technical Documentation Department

Product ID

Manufacturer:	Liebherr-France SAS
Type:	R 960 Demolition
Type no.:	1465, 1466, 1787 (USA / CAN)
From Serial no.:	39878

Contact

Liebherr-France SAS
2 avenue Joseph Rey, B.P. 90287
F – 68005 Colmar Cedex

CLICK HERE TO **DOWNLOAD** THE COMPLETE MANUAL

- Thank you very much for reading the preview of the manual.
- You can download the complete manual from: www.heydownloads.com by clicking the link below



- Please note: If there is no response to CLICKING the link, please download this PDF first and then click on it.

CLICK HERE TO **DOWNLOAD** THE COMPLETE MANUAL

3.3.4	Fire extinguisher (option)	121
3.3.5	Safety lever	121
3.3.6	Folding console	122
3.3.7	Operator's seat	123
3.3.8	Safety belt	131
3.3.9	Horn	132
3.3.10	Tilting operator's cab	133
3.3.11	Sun blinds	135
3.3.12	Side windows	137
3.3.13	Viewing devices	137
3.3.14	Lighting	143
3.3.15	Cab lighting system	144
3.3.16	Windscreen wipers	145
3.3.17	Compressed air system	146
3.3.18	Auxiliary heater (option)	147
3.4	Operation	148
3.4.1	Inspection tour before putting into service	148
3.4.2	Refuelling	149
3.4.3	Refuelling with the electric refuelling pump (option)	150
3.4.4	Refuelling diesel exhaust fluid	152
3.4.5	Immobiliser (option)	153
3.4.6	Preparing machine for dust intensive application	154
3.4.7	Preparing machine for use in biologically sensitive areas	155
3.4.8	Starting diesel engine	155
3.4.9	Bringing machine to operating temperature	156
3.4.10	Engine speed and operating mode	157
3.4.11	After starting	158
3.4.12	Sensor-controlled low idle automatic	159
3.4.13	Automatic engine shut-off after idling (option)	160
3.4.14	Shutting off diesel engine	160
3.4.15	Travelling and braking	163
3.4.16	Travel alarm (option)	166
3.4.17	Controlling the working attachment	167
3.4.18	Controlling demolition attachment	168
3.4.19	Turning and braking uppercarriage	170

1.1.3 Uppercarriage

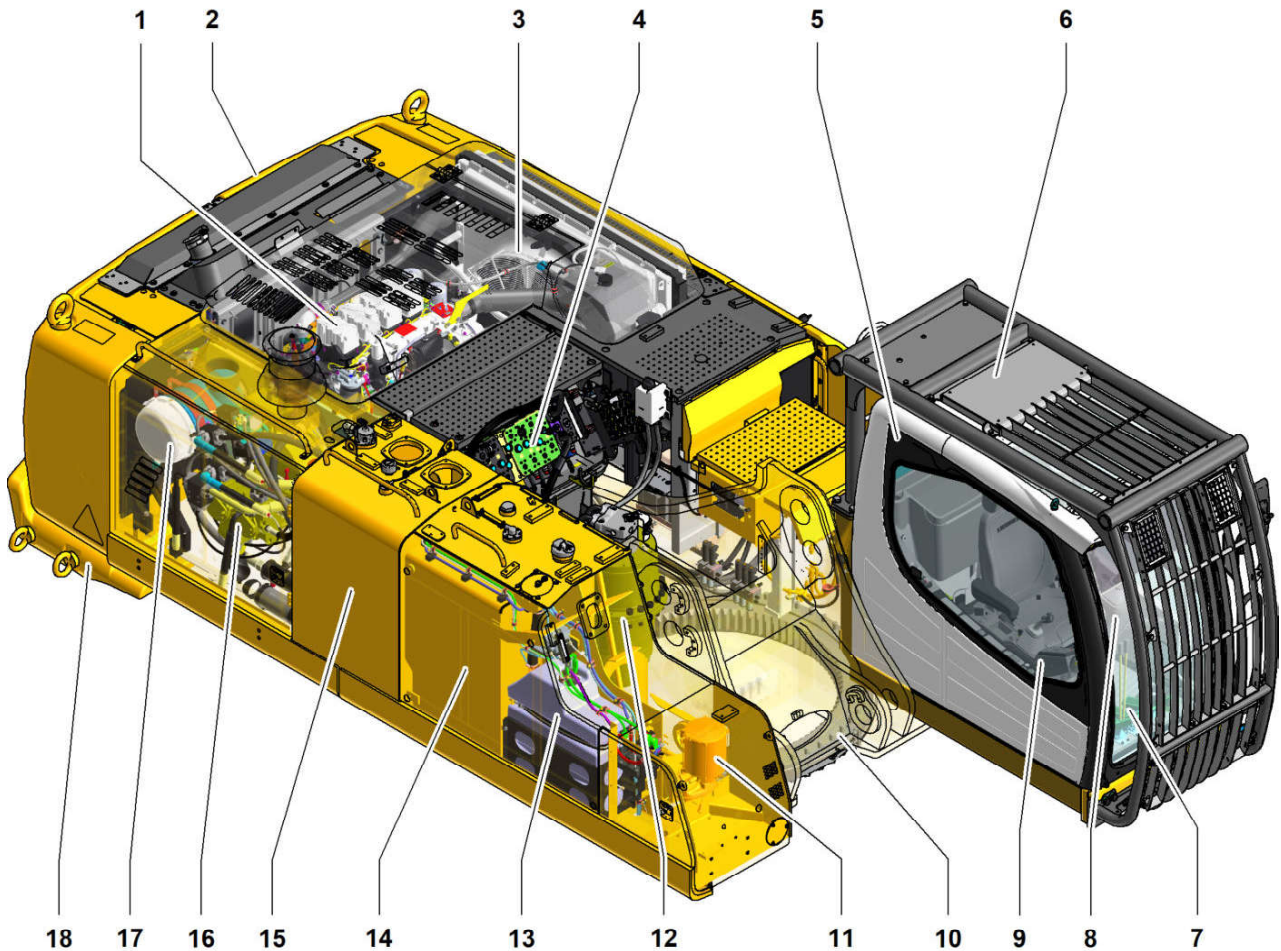

Fig. 3: Uppercarriage

- | | | |
|------------------------|-----------------------|------------------------------|
| 1 Diesel engine | 7 Operator's platform | 13 Diesel exhaust fluid tank |
| 2 Counterweight | 8 Left console | 14 Fuel tank |
| 3 Radiator | 9 Right console | 15 Hydraulic tank |
| 4 Control valve block | 10 Slewing ring | 16 Hydraulic pump |
| 5 Operator's cab | 11 Grease container | 17 Air filter |
| 6 Protective structure | 12 Slewing gearbox | 18 Additional counterweight |



Operator's Cab

Cab	Safety cab structure, headlight integrated under the protection, a door with a sliding window (can be opened on both sides), large storing box and several stowing possibilities, shock-absorbing suspension, sounddamping insulating, tinted laminated safety glass, separate window shades for the sunroof window and windscreen, cigarette lighter and 12 V plug, storage bins, lunchbox, cup holder, polycarbonate windows on right side
Operator's seat	Liebherr-Comfort seat, airsprung with automatic weight adjustment, vertical and longitudinal seat damping including consoles and joysticks. Seat and armrests adjustable separately and in combination, seat heating as standard
Control system	Arm consoles, swinging with the seat
Operation and displays	Large high-resolution color display with intuitive operation via touchscreen, video, additional color display for front and side camera, versatile adjusting, control and monitoring facilities, e.g. climate control, implement and attachment parameters, specific demolition display
Air-conditioning	Standard automatic air-conditioning fully controlled on the display, ambient air function, fast de-icing and demisting at the press of a button, air vents can be operated via a menu. Ambient air and fresh air filters can be easily replaced and are accessible from outside and standing on the ground. Heating-cooling unit, designed for extreme outside temperatures, sensors for solar radiation, inside and outside temperatures
Noise emission	
ISO 6396	L _{PA} (inside cab) = 72 dB(A)
2000/14/EC	L _{WA} (surround noise) = 106 dB(A)



Undercarriage

Versions	
VH-HD	Hydraulic variable gauge
HD-EW	Removable side frames
Drive	Liebherr swashplate motor with brake valves on both sides
Transmission	Liebherr compact planetary reduction gear
Maximum travel speed	Low range 2.0 km/h / 1.2 mph High range 3.2 km/h / 2.0 mph
Net drawbar pull on crawler	563 kN / 126,567 lbf
Track components	D8K, maintenance-free
Track rollers/Carrier rollers	11/2
Tracks	Sealed and greased
Track pads	Double grouser
Holding brake	Wet multi-disc (spring applied, pressure released)



Equipment

Type	Combination of resistant steel plates and cast steel components
Hydraulic cylinders	Liebherr cylinders with seal and guidance systems
Bearings	Sealed, low maintenance
Lubrication	Automatic central lubrication system (except link and tilt geometry)
Hydraulic connections	Pipes and hoses equipped with SAE split-flange connections
Buckets	Standard equipped with Liebherr tooth system

Dimensions and Weights

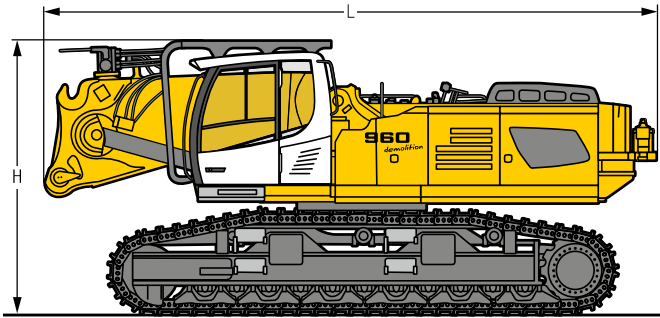

Basic Machine

without counterweight with cab tiltable 30° and integral protection grid

		VH-HD	HD-EW
L	mm / ft in	8,100 / 26' 7"	8,100 / 26' 7"
H	mm / ft in	3,600 / 11' 10"	3,660 / 12'
Weight	kg / lb	59,100 / 130,290	54,100 / 119,270

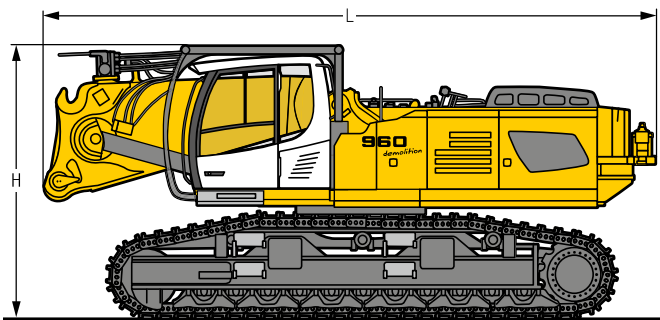

Basic Machine

without counterweight with cab tiltable 30° and integral protection grid on tilting device

		VH-HD	HD-EW
L	mm / ft in	8,100 / 26' 7"	8,100 / 26' 7"
H	mm / ft in	3,600 / 11' 10"	3,660 / 12'
Weight	kg / lb	59,500 / 131,180	54,500 / 120,150

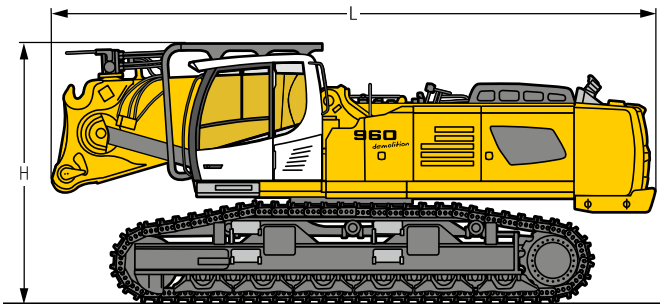

Basic Machine

with counterweight 11.8 t / 26,020 lb and 4 t / 8,820 lb removable, cab tiltable 30° and integral protection grid

		VH-HD	HD-EW
L	mm / ft in	8,450 / 27' 9"	8,450 / 27' 9"
H	mm / ft in	3,600 / 11' 10"	3,660 / 12'
Weight	kg / lb	75,100 / 165,570	70,100 / 154,540

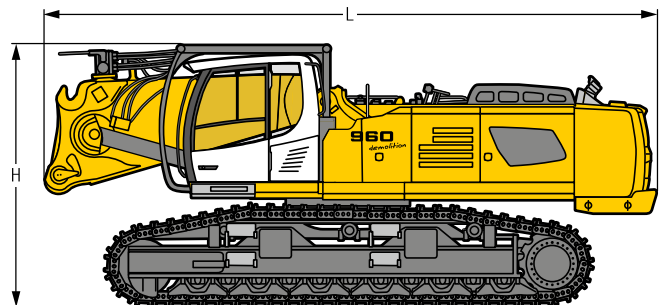

Basic Machine

with counterweight 11.8 t / 26,020 lb and 4 t / 8,820 lb removable, cab tiltable 30° and integral protection grid on tilting device

		VH-HD	HD-EW
L	mm / ft in	8,450 / 27' 9"	8,450 / 27' 9"
H	mm / ft in	3,600 / 11' 10"	3,660 / 12'
Weight	kg / lb	75,500 / 166,450	70,500 / 155,430

- When moving machine with loaded goods, adhere to safety stipulations ([For more information see: 2.7.9 Load-lifting work, page 59](#)).
- For special uses use special working attachments and if necessary special safety equipment.
- Exclusively mount and use special working attachments with permission and as per stipulations of manufacturer of basic machine.

**Note**

- ▶ Any other use or use beyond the stated use is improper use.

2.2.3 Foreseeable misuse

Do not use machine in following cases:

- Transport of persons without mounted and functioning safety equipment
- Lifting of persons without mounted and functioning safety equipment
- Work in explosive environment without corresponding and necessary equipment
- Work in contaminated environment without corresponding and necessary equipment
- Sweeping on side (with working attachment)
- Stamping
- Striking
- Lifting loads with earthmoving attachment without suitable means
- Lifting loads with demolition attachment, regardless which working tool or which quick coupler is mounted
- Pulling and pushing of vehicles or objects without suitable towing attachments and brakes on machine
- ([For more information see: 2.7.10 Demolition work, page 59](#)) ([For more information see: 2.8.1 Demolition machines, page 60](#))

**Note**







- ▶ The manufacturer is not liable for damage caused by improper use.

2.2.4 Operating conditions

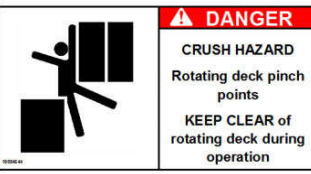
- Operate machine in an ambient temperature of -4 °F to 104 °F.
- In case of divergent ambient temperatures, contact Liebherr customer service.
- In case of deployments at below 14 °F, adhere to diesel fuel quality ([For more information see: 5.3.1 Diesel fuels, page 327](#)).
- In case of deployments at below 14 °F, use preheatings or arctic diesel (for more information on arctic diesel qualities, see table 1 and DIN EN 590).
- Adhere to operating temperatures of diesel fuels.

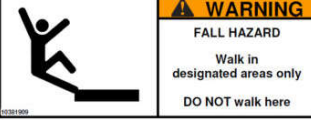
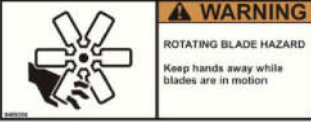
Permitted diesel fuels as per DIN EN 590	Cloud point	Ambient temperature
Standard winter diesel	19 °F	To 14 °F
Arctic class 0	14 °F	To 9 °F
Arctic class 1	3 °F	To -4 °F

Tab. 6: Operating temperatures of diesel fuels

	Sign	Description
1		<p>Danger!</p> <p>Danger of crushing in the slewing area of the uppercarriage. Remaining in danger area is prohibited.</p>
2		<p>Danger!</p> <p>Danger of impact and danger of impaling during machine operation. Remaining in the working area of the machine is prohibited.</p>
3		<p>Lifting prohibited</p> <p>Displayed lifting point is unsuitable for lifting entire machine. Do not lift machine by this lifting point. Adhere to instructions in operator's manual on lifting machine.</p>
4		<p>Prohibited zone</p> <p>Danger of falling. Remaining in the indicated areas is prohibited.</p>
5		<p>Engine shut-off</p> <p>Risk of injury. Exclusively open hood with diesel engine shut off.</p>
6		<p>Risk of explosion</p> <p>Do not smoke. Avoid flames in indicated areas, particularly areas with charging batteries.</p>
7		<p>Risk of electric shock</p> <p>Adhere to a distance of at least 49' 3" ft-in between all parts of working attachment and high voltage cables.</p>
8		<p>Risk of injury</p> <p>Risk of injury from fluids emerging under high pressure.</p>
9		<p>Risk of burns</p> <p>Risk of burns from contact, particularly in area of exhaust silencer.</p>

2.6 Emergency equipment on the machine

2.6.1 Emergency exit (standard)

Danger to life

Incorrect labelling

- Make sure that all information signs are present.
- Make sure that all information signs are legible.

Incorrect equipment

- Make sure that emergency hammer is present.
- Make sure that position of emergency hammer is known.

2.6.2 Fire extinguisher (option)

Danger to life

Incorrect behaviour

- Make sure that all fastening points of fire extinguishers on the machine are known.
- Make sure that everyone is able to operate the fire extinguishers.
- Make sure that everyone knows the local fire alarm possibilities.
- Make sure that everyone knows the local fire-fighting possibilities.
- Before starting machine, unlock all locks of hoods and doors of machine.
- Make sure that check and inspection are performed on time.

2.6.3 Emergency command devices of machine

Depending on equipment, machine has following emergency command devices:

- Emergency stop device
- Emergency cut-off device
- Emergency brake

Danger to life

Defective emergency command devices

- Make sure that all emergency command devices are functioning correctly.
- Regularly check all emergency command devices for function.
- Have defective emergency command devices repaired immediately.

Damage to machine

Incorrect use of emergency command devices

- Exclusively use emergency command devices if there is immediate danger.

2.8.2 Hydraulic hammer

Danger to life

Unsuitable ground

- Make sure that machine does not sink.
- Check load capacity of ground.
- Remove obstacles from working area.

Incorrect use

- If machine is equipped with undercarriage with adjustable width: Extend side frames to the stop.

Damage to machine

Incorrect use of hydraulic hammer

- Exclusively use hydraulic hammers approved by Liebherr. Use of a hydraulic hammer not approved by Liebherr will invalidate warranty on structural elements of machine.
- Exclusively use hydraulic hammer to break stone, concrete and brittle materials.
- Do not break concrete or rock by moving hydraulic hammer into and out of material.
- Operate hydraulic hammer for no more than 15 s without interruption in one location.

Incorrect use

- When movements approach cylinder stops: Reduce speed of movements.

2.8.3 Scaling tooth

Danger to life

Unsuitable ground

- Make sure that machine does not sink.
- Check load-bearing capacity of ground.
- Remove obstacles from working area.

Incorrect use

- If machine is equipped with undercarriage with adjustable width: Extend side frames to the stop.

Damage to machine

Incorrect use of scaling tooth

- Exclusively use scaling tooth approved by Liebherr. Use of a scaling tooth not approved by Liebherr will invalidate warranty on structural elements of machine.
- Exclusively use scaling tooth to break stone, concrete and brittle materials.

3.2 Display

3.2.1 Display

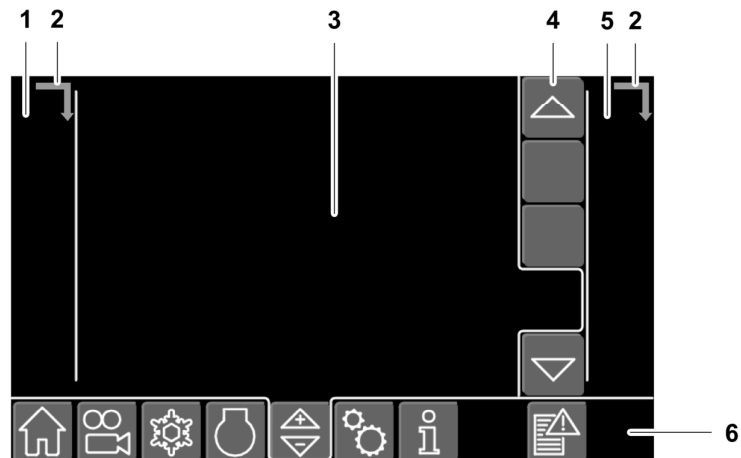

Fig. 66: Display

- | | | | |
|---|-----------------------|---|-------------|
| 1 | Status bar | 4 | Submenu bar |
| 2 | Further symbols arrow | 5 | Warning bar |
| 3 | Display field | 6 | Menu bar |



Note

The arrow indicates that further symbols are available in the status bar or warning bar on the display.

The symbols are displayed alternately under the *Further symbols* arrow 2.

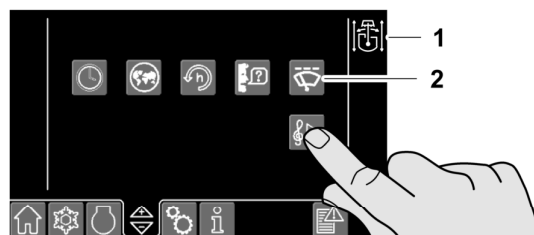

Fig. 67: Symbols with a grey background are buttons

- | | | | |
|---|--------|---|--------|
| 1 | Symbol | 2 | Button |
|---|--------|---|--------|



Fig. 150: Additional display

- | | | | | | |
|---|---|---|--|---|-----------------------------------|
| 1 | Image of front area camera | 4 | Adjusting contrast of side area camera menu button | 7 | Increasing camera contrast button |
| 2 | Adjusting display menu button | 5 | Image of side area camera | | |
| 3 | Adjusting contrast of front area camera menu button | 6 | Reducing camera contrast button | | |

**DANGER**

Restricted field of view for camera!
Danger to life.

- ▶ Pay close attention to the working area and driveway of the machine.

In case of malfunction of a camera:

- ▶ Exclusively manoeuvre with support of an additional person.

- ▶ Set display: Press *adjusting display* menu button **2**.
- ▶ Select required menu for contrast setting: Press *adjusting contrast of front area camera* menu button **3** or *adjusting contrast of side area camera* menu button **4**.
- ▶ Set contrast: Press *reducing camera contrast* button **6** or *increasing camera contrast* button **7**.

3.2.5 Air conditioning

Menu call: 

The cab temperature can be adjusted between 61 °F and 82 °F:

- Maximum cooling power is 61 °F.
- Maximum heating power is 82 °F.

Kenwood radio (option)

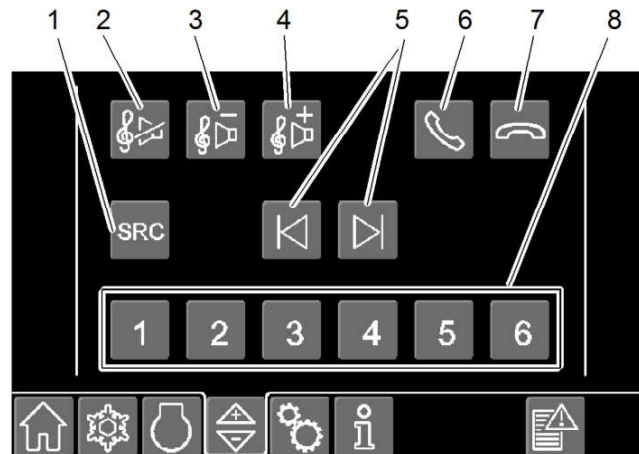

Fig. 179: Radio remote control submenu

- | | | | |
|---|-------------------------------|---|---|
| 1 | Selecting audio source button | 5 | Changing radio station or track buttons |
| 2 | Mute button | 6 | Answering phone call button |
| 3 | Reducing volume button | 7 | Ending phone call button |
| 4 | Increasing volume button | 8 | Selecting stored radio station buttons |

3.2.14 Display brightness and display volume submenu

Menu call:  >  or  >  > 

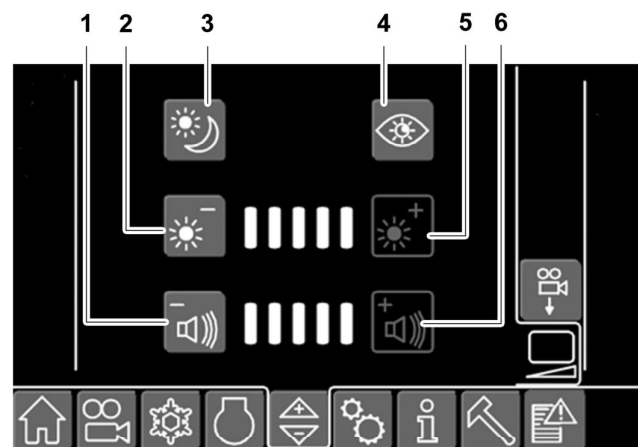

Fig. 180: Display brightness and display volume submenu

- | | | | |
|---|--------------------------------|---|--|
| 1 | Reducing display volume button | 4 | Night Shift mode button ¹⁰⁾ |
|---|--------------------------------|---|--|

[See next page for continuation of the image legend](#)

¹⁰⁾ Available depending on machine type

3.2.28 Maintenance submenu

Menu call:  >  or  > 

Access path and display of this submenu vary depending on machine configuration:

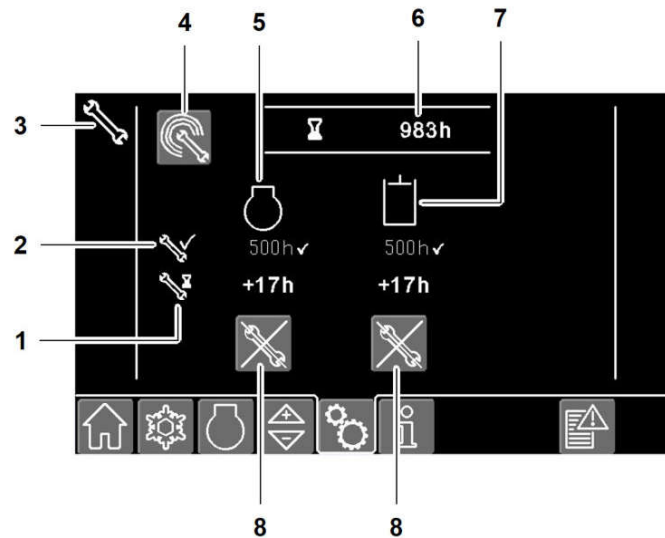

Fig. 211: Maintenance submenu

1	Remaining time to next maintenance	5	Maintenance of diesel engine
2	Operating hour meter at last maintenance	6	Total operating hours
3	<i>Maintenance due</i> status symbol	7	Hydraulic system maintenance
4	<i>Teleservice</i> button	8	<i>Confirmation of maintenance due message</i> button

Maintenance

If next maintenance is due in less than 100 hours or deadline has been exceeded by 100 hours, the following elements are displayed:

- *Maintenance due* status symbol **3**
- *Confirmation of maintenance due message* button **8**

▶ Hide *maintenance due* message: Press *confirmation of maintenance due message* button **8**.

▷ *Maintenance due* status symbol **3** disappears.

▶ Have maintenance performed at specified time: Contact Liebherr customer service.

Teleservice

Via Teleservice Liebherr customer service reads and modifies parameters of machine control online if necessary.









NOTICE

Unsuitable parameters!

Damage to special working attachment.

- ▶ Select suitable parameters for special working attachment.
 - ▶ Adhere to maximum permitted values for pressure and flow rate.
-
- ▶ Press *scroll* buttons **1** until desired *selected special working attachment* button **2** is outlined in white.
 - ▶ Press required *selected special working attachment* button **2**.
 - ▷ Name of special working attachment is displayed in green.
 - ▷ Special working attachment is selected.
 - ▷ Parameters of special working attachment are activated.

3.2.39 Tool Control symbols

Symbol	Meaning
	Automatically forced selection of working tool
	Working tool in continuous mode
	Control changeover activated
	Shear selected
	Mill selected
	Dual circuit tiltrotator selected
	Pulveriser selected
	Mowing bucket selected
	Flow distributor selected

3.3.4 Fire extinguisher (option)

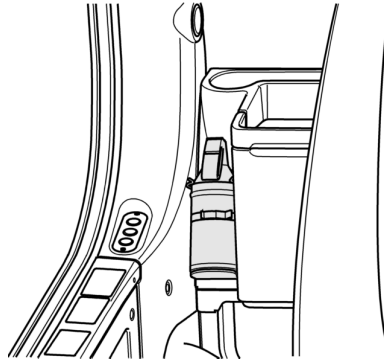

Fig. 281: Fire extinguisher

The fire extinguisher is in the operator's cab.

- ▶ Have fire extinguisher inspected according to the regulations in force where the machine is used.
- ▶ Observe operating instructions on fire extinguisher.



Note

The operator is responsible for installing the fire extinguisher.

- ▶ Observe regulations in force where machine is used.
- ▶ Estimate requirement in relation to operational conditions.
- ▶ Order fire extinguisher and holder: Contact Liebherr customer service.

3.3.5 Safety lever

The safety lever:

- interrupts all hydraulic functions,
- makes it possible to avoid all unintentional movements of the machine.

The engine can only be started when the safety lever is in the upper position.

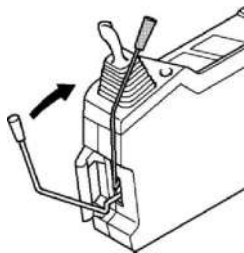

Before starting work:

- ▶ Sit in the operator seat.
- ▶ Start the engine.
- ▶ Move the safety lever to the down position.
 - ▷ The joysticks and the pedals are working.
 - ▷ The slewing gear break returns to its previous state.

Before you stand up:

- ▶ Move the safety lever to the upper position.
 - ▷ The joysticks and the pedals are not working any more.
 - ▷ The slewing gear brake is activated and locked.

Switching seat heating with seat air conditioning on and off (option)

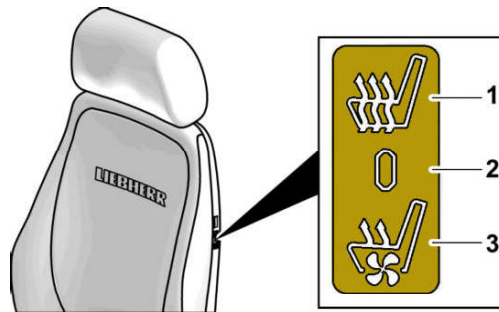

Fig. 302: Seat heating with seat air conditioning

- | | | | |
|---|---|---|---------------------------------|
| 1 | Switch on seat heating | 3 | Switch on seat air conditioning |
| 2 | Switch off seat heating and seat air conditioning | | |

3.3.8 Safety belt

The safety belt is an automatic safety belt. It does not need to be adjusted.

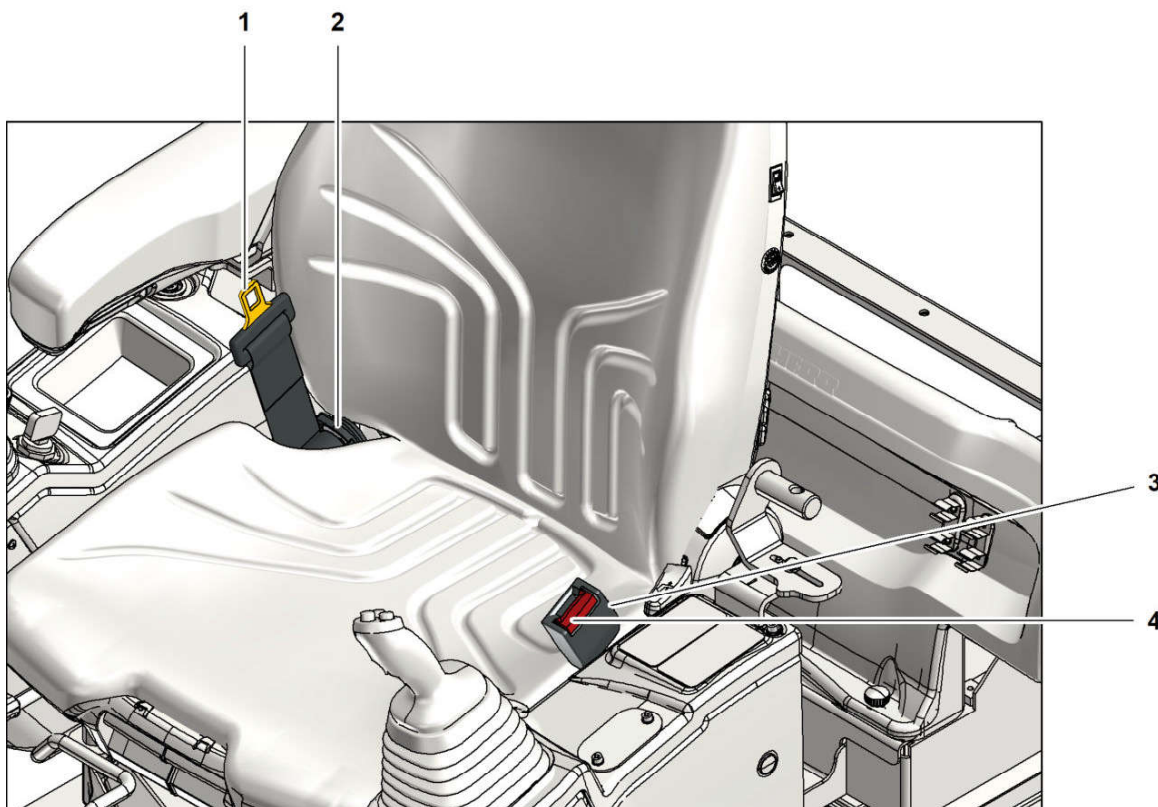

Fig. 303: Safety belt

- | | | | |
|---|-------------------|---|------------------|
| 1 | Belt buckle latch | 3 | Belt buckle |
| 2 | Belt reel | 4 | Unlocking button |

Adjusting rear area camera

- ▶ Contact Liebherr customer service.

Side area camera

Checking blue area covered by side area camera

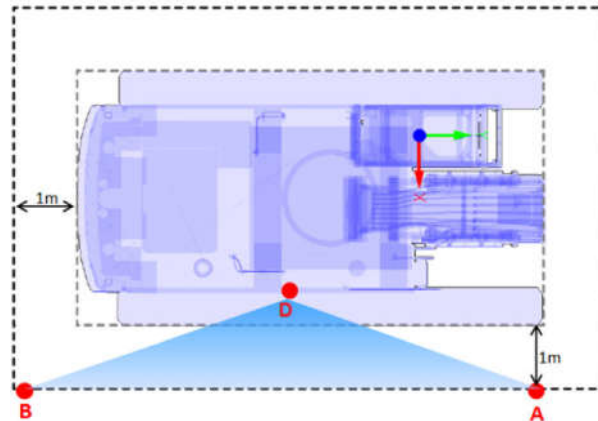

Fig. 317: Checking blue area covered by side area camera



Fig. 318: Additional display

- ▶ Align uppercarriage parallel to undercarriage.
- ▶ Place object **A** at 3' 3" ft-in height and 3' 3" ft-in distance from right side of machine and in front of right track.
- ▶ Place object **B** on the ground at 3' 3" ft-in distance from right side of machine and 3' 3" ft-in distance behind counterweight.
- ▶ On display of operator's cab check blue area covered by side area camera.
 - ▷ Objects **A** and **B** are visible in bottom corners of side area camera image.
 - ▷ Right side **D** of machine is visible in bottom area of side area camera image.
 - ▷ Camera image must cover area of at least 39' 4" ft-in on right side of machine.

If blue area displayed by side area camera is not correct:

- ▶ Adjust side area camera. (For more information see: [Adjusting side area camera](#), page 142)

NOTICE

Penetration by moisture into fuel tank cap!
Damage to fuel system.

- ▶ Remove key from fuel tank cap.
 - ▶ Put on protective cap of fuel tank cap.
-

Starting refuelling with the electric refuelling pump

NOTICE

Incorrect refuelling with electric refuelling pump!
Damage to electric refuelling pump and machine.

- ▶ Use clean fuel.
 - ▶ Do not change length or diameter of suction hose.
 - ▶ Comply with the maximum suction head of electric refuelling pump.
 - ▶ Monitor correct progress of refuelling with electric refuelling pump.
-

Make sure the following preconditions are met:

- Diesel engine is shut off.
- Fuel used is approved. (For more information see: [5.3.1 Diesel fuels, page 327](#))
- Screen plate in foot valve 1 is clean and in good condition.
- ▶ Unlock fuel tank cap.
- ▶ Unscrew fuel tank cap.
- ▶ Unscrew protection plug of foot valve 1.
- ▶ Insert foot valve 1 until bottom of tank container is reached.
- ▶ Press *start* button 2.

Stopping refuelling with the electric refuelling pump

When refuelling has ended, electric refuelling pump switches off automatically.

- ▶ Switch off electric refuelling pump manually: Press *stop* button 3.
- ▶ Unscrew foot valve 1 from tank container.
- ▶ Screw in plug of foot valve 1.
- ▶ Wind up suction hose 4 and stow behind door of fuel tank.
- ▶ Screw in fuel tank cap.
- ▶ Lock fuel tank cap.



- ▶ Press *START STOP* key.
 - ▷ Engine speed slowly falls to idle speed, subsequently diesel engine is shut off.
 - ▷ If already at idle speed, diesel engine is shut off immediately.
 - ▷ LEDs in *START STOP* key go out.

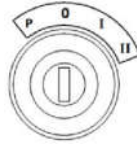

When diesel engine has been shut off:

- ▶ Set ignition key to **0**.
- ▶ Pull out ignition key.

Shutting off diesel engine with delay (option)



Before shut-off, diesel engine runs at idle speed for 30 seconds¹⁴⁾ and *engine stop activated* status symbol appears on the display.

- ▶ Shut off diesel engine normally. (For more information see: [Shutting off diesel engine normally, page 160](#))
- ▶ Remain in the operator's cab during the shut-off delay.

Shutting off diesel engine in emergency with the ignition key

- ▶ Set ignition key to **0**.

Shutting off diesel engine in emergency with emergency stop button (option)

Depending on machine configuration following emergency stop buttons are available:

- In operator's cab
- On right side of uppercarriage
- On left side of uppercarriage

¹⁴⁾ 60 seconds for R 976 and R 980

- ▶ Press *slewing brake* key.
 - ▷ LEDs in *slewing brake* key light up.

Deactivating manual locking

- ▶ Press *slewing brake* key.
 - ▷ LEDs in *slewing brake* key go out.

Semi-automatic locking (option)

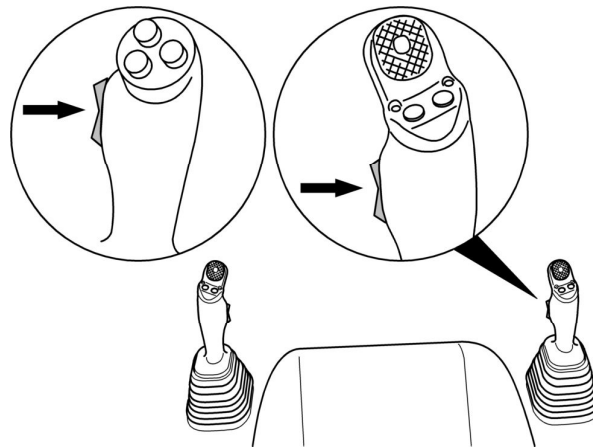

Fig. 384: Semi-automatic locking

Activating semi-automatic locking

- ▶ Move switch on right joystick down.
 - ▷ Slewing brake is applied when uppercarriage is stationary or is just about to stop.

Deactivating semi-automatic locking

- ▶ Move switch on right joystick up.
 - ▷ Slewing brake is released.



Automatic locking

Automatic locking is not stored when the ignition is switched off.

The slewing brake is released when engine is switched on again.

Slewing brake is applied when uppercarriage is stationary or is just about to stop.

Slewing brake is released as soon as left joystick is moved.

Key	Status of LEDs	Slewing brake
		Applied
		Released

Tab. 34: Automatic locking

3.4.24 Controlling special working attachment with mini-joystick

Selecting special working attachment

If available:

- ▶ Select special working attachment from *Tool Control* menu on the display.

Controlling special working attachment with left mini-joystick

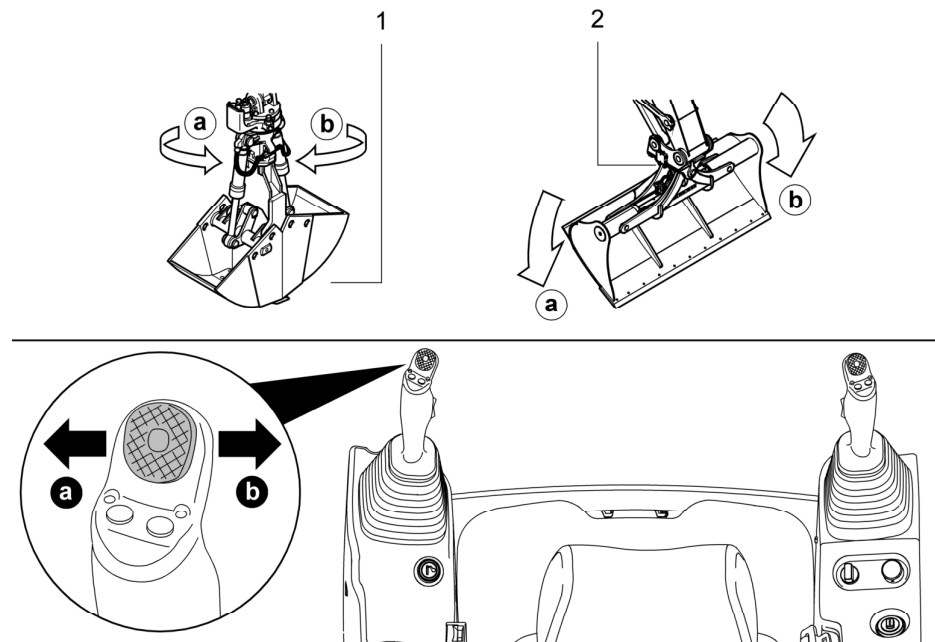

Fig. 418: Controlling special working attachment with left mini-joystick

- | | |
|--|--|
| <p>1 Grapple with rotary actuator</p> <ul style="list-style-type: none"> ▶ Swivel special working attachment to left a: Move left mini-joystick in direction a and hold position. ▶ Swivel special working attachment to right b: Move left mini-joystick in direction b and hold position. | <p>2 Swivelling ditch-cleaning-bucket</p> |
|--|--|

3.4.25 Controlling hydraulic hammer

The *description of control elements* information sign describes the control elements of the excavator control.



WARNING

Unintended movements of the machine!
Death from impact or crushing.

- ▶ Before working with machine, check function of control elements.

3.5.2 Overload warning system (option)

Overload warning system is deactivated automatically if demolition attachment is installed on the machine.



Overload warning system warns operator that maximum permitted load is reached or exceeded:

- *Overload warning system* status symbol appears on the display.
- Acoustic warning signal sounds in operator's cab.
- Control elements of the machine remain operational.

Maximum permitted load is dependent on machine configuration (undercarriage, working attachment). Maximum permitted load is shown in load lift chart in operator's cab.

Specified loads according to ISO 10567 correspond to 75 % of the static tip load or 87 % of the hydraulic limit.

Load capacity varies dependent on the following points:

- Installation of parts of the working attachment
- Removal of parts of the working attachment
- Changing of the working tool

The overload warning system does not release the operator from the responsibility of exclusively lifting loads that are known and approved according to machine load lift chart.

Checking function of the overload warning system

Every time the machine is started and before loads are lifted, the function of the overload warning system must be checked.



DANGER

Failure of overload warning system!
Death, injuries, damage.

- ▶ Do not lift any loads.
 - ▶ Have overload warning system repaired.
-
- ▶ Slowly extend hoist cylinder up to stop.
 - ▶ Continue to operate hoist cylinder when stop is reached.
 - ▷ *Overload warning system* status symbol appears on the display.
 - ▷ Acoustic warning signal sounds in operator's cab.

Activating overload warning system

Overload warning system is activated by default.

- ▶ Press *overload warning system* key.
 - ▷ LEDs in *overload warning system* key light up.



CLICK HERE TO **DOWNLOAD** THE COMPLETE MANUAL

- Thank you very much for reading the preview of the manual.
- You can download the complete manual from: www.heydownloads.com by clicking the link below



- Please note: If there is no response to CLICKING the link, please download this PDF first and then click on it.

CLICK HERE TO **DOWNLOAD** THE COMPLETE MANUAL

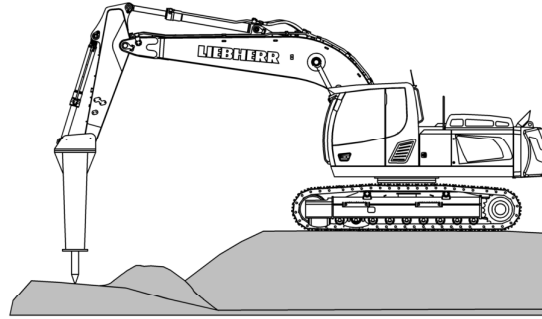

Fig. 477: Working with hydraulic hammer



WARNING

Machine tipping over!
Danger to life.

- ▶ Exclusively work in permitted working area.

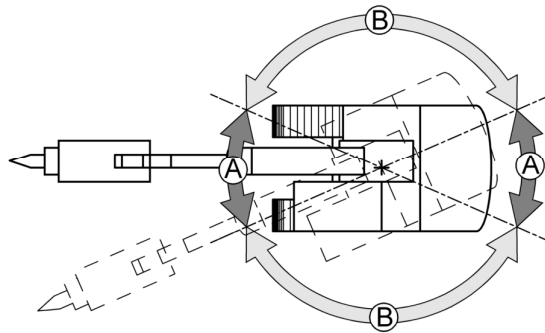

Fig. 478: Work areas

A Permitted working area

B Not approved working area



WARNING

Rockfall!
Danger to life.

- ▶ Work exclusively with hydraulic hammer in vertical position.
- ▶ Close all windows of operator's cab.

Machine	Configuration of demolition attachment	Length of demolition boom	Length of extension of demolition boom	Length of demolition stick	Attachment points
R950 Demolition	Standard	7.7 m	/	7.3 m	Individual
		7.7 m	2.5 m	7.3 m	
		10.2 m	/	7.3 m	Front
	Specific	6 m	/	7.3 m	Individual
			2.5 m	7.3 m	
			/	7.3 m	
		11.2 m	/	9 m	Back
			/	9 m	
		10.2 m	2.5 m	9 m	
	Specific, without quick coupler	10.2 m	2.5 m	7.3 m	Back

Tab. 42: Attachment points of machine R950 Demolition

Dismount pedestal and dismount device

The dismount pedestal and the dismount device make installation, removal and storage of demolition attachment easier.



WARNING

Falling!
Danger to life.

If dismount pedestal or dismount device are not equipped with walkway:

- ▶ Use secured third-party equipment to access required elements.



WARNING

Fall of working attachment!
Danger to life.

- ▶ Use dismount pedestal or dismount device on load-bearing and level ground.

Make sure the following preconditions are met:

- Demolition attachment and machine are on load-bearing and level ground.
- Uppercarriage and undercarriage are perfectly aligned.
- Machine and demolition attachment are perfectly aligned.

If machine is equipped with undercarriage with adjustable width:

- ▶ Extend side frames. (For more information see: [3.10.2 Adjusting undercarriage width mechanically \(option\), page 265](#)) (For more information see: [3.10.3 Adjusting undercarriage width hydraulically \(option\), page 269](#))
- ▶ Insert demolition boom **5** in open end of basic boom **10**: Move machine forwards slowly and carefully.
- ▶ Hook upper pin **7** into hook **9**: Lift basic boom **10**.
- ▶ Connect all hydraulic hoses and all lubricant hoses between basic boom **10** and demolition boom **5** using quick couplings.
- ▶ Connect electrical connections.
- ▶ Make sure that code plugs are connected correctly. (For more information see: [After installing working attachment, page 209](#))
- ▶ If necessary install additional counterweight. (For more information see: [Installing additional counterweight on counterweight, page 251](#)) (For more information see: [Installing additional counterweight on counterweight, page 258](#))
- ▶ Remove dismount pedestal or dismount device.
- ▶ Align bore in lower pin **6** with lower pin **8**: Use stops **11**.
- ▶ Slowly and carefully lift basic boom **10**.
- ▶ Install lower pin **8**.

or

If demolition attachment is equipped with quick coupler:

Lock quick coupler. (For more information see: [3.7.13 Hydraulic quick coupler for working attachment parts \(option\), page 237](#))

- ▶ Make sure that there is 0.04" to 0.08" in play between basic boom **10** and stops **11**.



WARNING

Unexpected lowering of demolition stick!
Danger to life.

- ▶ Support front end of demolition stick with wooden blocks.
-
- ▶ Remove locking bar **3** on side of demolition stick **2** and mount free end on intended mounting point of demolition boom **5**.
 - ▶ Select working tool mounted on machine in *Tool Control* menu.

Disconnecting earthmoving attachment

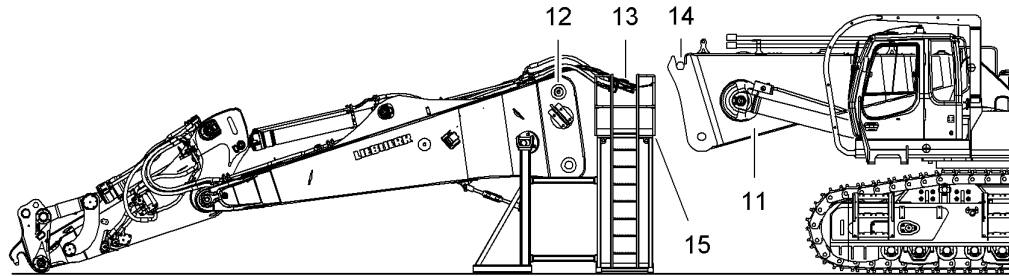

Fig. 512: Disconnecting earthmoving attachment

11 Basic boom
12 Upper pin

13 Quick couplings
14 Hook

15 Walkway

- ▶ Depressurise hydraulic system.
- ▶ Climb walkway 15: Use ladder.

If machine is equipped with hydraulic quick couplings:

- ▶ Disconnect hydraulic quick couplings. (For more information see: [Disconnecting hydraulic hoses with quick couplings, page 235](#)) or (For more information see: [Uncoupling, page 236](#))
- ▶ Disconnect all hydraulic hoses and all lubricant hoses between basic boom 11 and main boom at quick couplings 13.
- ▶ Remove electrical connections.
- ▶ Start diesel engine.
- ▶ Unhook upper pin 12 from hook 14: Slowly and carefully lower basic boom 11.
- ▶ Move machine backwards slowly and carefully.
 - ▷ Earthmoving attachment is disconnected from machine.

3.7.10 Lifting earthmoving attachment from dismount device and installing on machine

Procedure requires deployment of three persons:

- Operator in operator's cab
- Person on left side of dismount device (operator's cab side). This person gives operator necessary instructions
- Person on right side of dismount device

Connecting earthmoving attachment



WARNING

Movement of working attachment!
Danger to life.

- ▶ Before entering danger zone, make sure that working attachment has been lowered to the ground.

Locking quick coupler

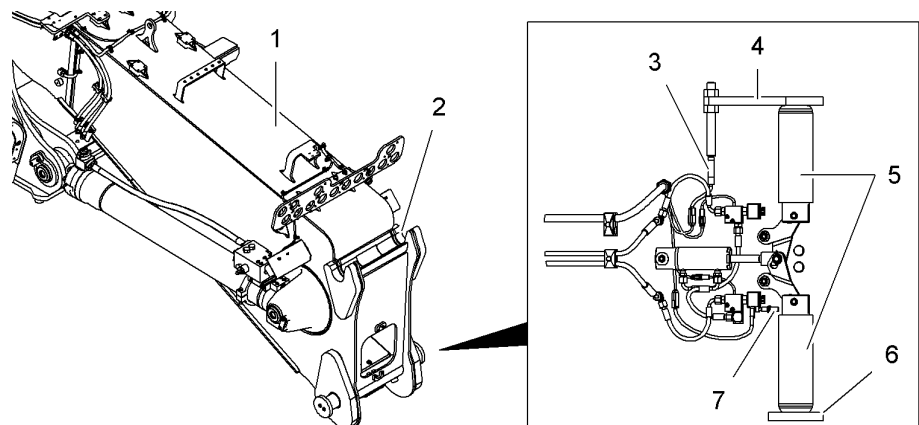
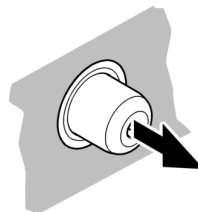
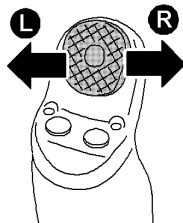

Fig. 542: Hydraulic quick coupler

- | | | | |
|---|---|---|------------------------------------|
| 1 | Permanent working attachment part | 5 | Lock pin |
| 2 | Hook | 6 | Right safety cover |
| 3 | Proximity switch/availability of safety cover | 7 | Proximity switch/lock pin extended |
| 4 | Left safety cover | | |

- ▶ Hook hook 2 of permanent working attachment part 1 into upper pin of working attachment part to be installed.
- ▶ Align lock pin 5 with bores of working attachment part to be installed: Lift permanent working attachment part 1.
- ▶ Press mini-joystick in direction L and hold there.
 - ▷ Lock pins extend as long as mini-joystick is pressed in direction L:



- ▷ Locking quick coupler status symbol appears on the display:



- ▷ Proximity switch 7 detects that lock pins are extended.
- ▷ Intermittent warning sound sounds.
- ▷ Quick coupler unlocked status symbol disappears from the display:



- ▷ Quick coupler activated status symbol disappears from the display:



LFR/11829208/01/2019-10-18/en

Additional counterweight

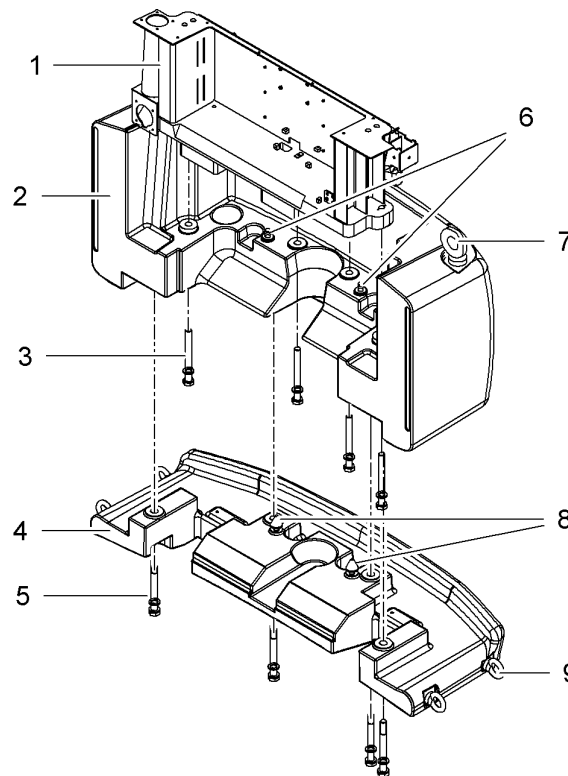

Fig. 555: Installing and removing counterweights

- | | | | |
|---|---|---|--|
| 1 | Rotary stage | 6 | Centring piece |
| 2 | Counterweight | 7 | Lifting eyelet of counterweight |
| 3 | Mounting bolt of counterweight | 8 | Centring piece |
| 4 | Additional counterweight | 9 | Lifting eyelet of additional counterweight |
| 5 | Mounting bolt of additional counterweight | | |

Installing additional counterweight on counterweight

The additional counterweight must exclusively be installed for following demolition attachments:

- 108' 3" ft-in (R960 Demolition)
- 82' ft-in (R950 Demolition)



Note

Additional counterweight is under the counterweight.
Slings must be aligned parallel with side wall of counterweight.

- ▶ Install additional counterweight: Use two lifting accessories simultaneously or one crossbeam.
- ▶ Screw in lifting eyelets of additional counterweight 9 so that they are aligned with axle of slings.
- ▶ Attach both slings to lifting eyelets of additional counterweight 9.
- ▶ Put additional counterweight 4 in horizontal position: Adjust length of slings.

Counterweight and additional counterweight as a unit

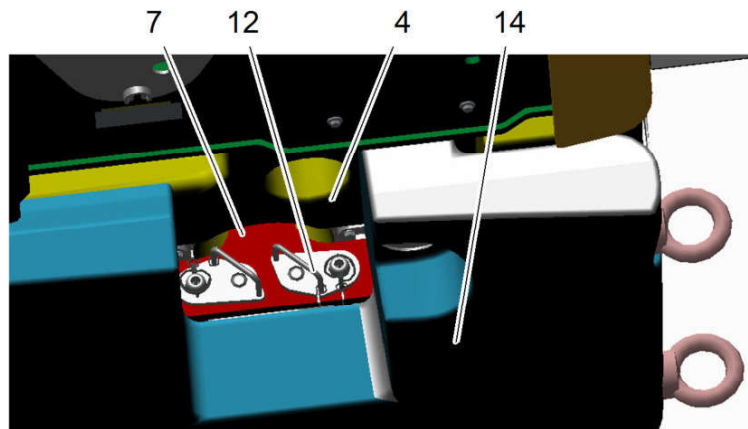

Fig. 564: Position of fastenings in additional counterweight

4	Counterweight	12	Fastening
7	T-piece	14	Additional counterweight

Installing counterweight and additional counterweight as a unit

Make sure the following preconditions are met:

- Fastenings 12 are positioned correctly for mounting additional counterweight 14 on T-piece 7.
- ▶ Adhere to procedure for installing counterweight on uppercarriage. ([For more information see: Installing counterweight to uppercarriage, page 256](#))

Removing counterweight and additional counterweight as a unit

Make sure the following preconditions are met:

- Fastenings 12 are positioned correctly for mounting additional counterweight 14 on T-piece 7.
- ▶ Adhere to procedure for removing counterweight. ([For more information see: Removing counterweight, page 257](#))

Retracting side frames

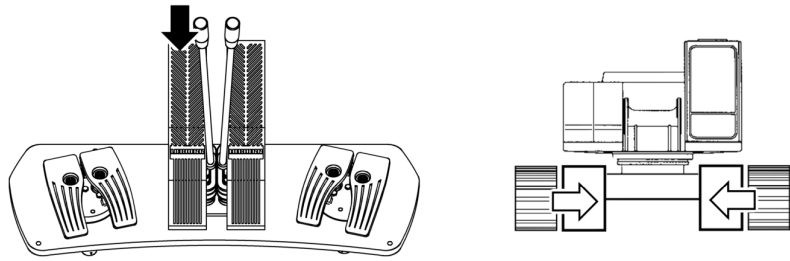

Fig. 577: Retracting side frames

Make sure the following preconditions are met:

- ❑ Travelling pedals are not actuated.
- ▶ Clean exposed surfaces of raceways.
- ▶ Lubricate raceways. (For more information see: [Lubricating raceways, page 400](#))
- ▶ Press *hydraulically adjustable undercarriage width* key.
 - ▷ *Confirmation required* status symbol appears on the display.
 - ▷ LEDs in *hydraulically adjustable undercarriage width* key flash.



- ▶ Press confirmation button within 5 seconds.
 - ▷ *Confirmation required* status symbol disappears.
 - ▷ LEDs in *hydraulically adjustable undercarriage width* key light up.
 - ▷ *Hydraulically adjustable undercarriage width* status symbol appears on the display:



- ▶ Press left travelling pedal forwards.
 - ▷ Side frames are retracted.

When both side frames are at the stop:

- ▶ Release left travelling pedal.
- ▶ Press *hydraulically adjustable undercarriage width* key.
 - ▷ *Confirmation required* status symbol appears on the display.
 - ▷ LEDs in *hydraulically adjustable undercarriage width* key flash.







- ▶ Press confirmation button within 5 seconds.
 - ▷ *Confirmation required* status symbol disappears.
 - ▷ LEDs in *hydraulically adjustable undercarriage width* key go out.
 - ▷ *Hydraulically adjustable undercarriage width* status symbol disappears from the display.
- ▶ Move safety lever up.
- ▶ Shut off diesel engine.
- ▶ Exit operator's cab and climb down.
- ▶ Check if side frames are in contact with middle part of undercarriage.

3.11 Emergency operation

3.11.1 Using emergency mode

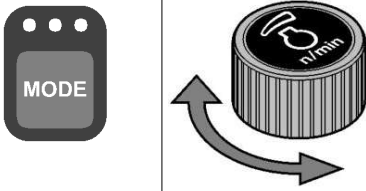
Exclusively use emergency mode to perform following measures:

- Starting diesel engine in the event of an electronic error
- Releasing slewing brake
- Forcing all machine movements

Status symbol	Inactive control element	Status
		Diesel engine at idle speed or rated speed
		Slewing brake released
		Machine movements slowed

Tab. 52: Properties of emergency mode

The main circuit board is behind the operator's seat.

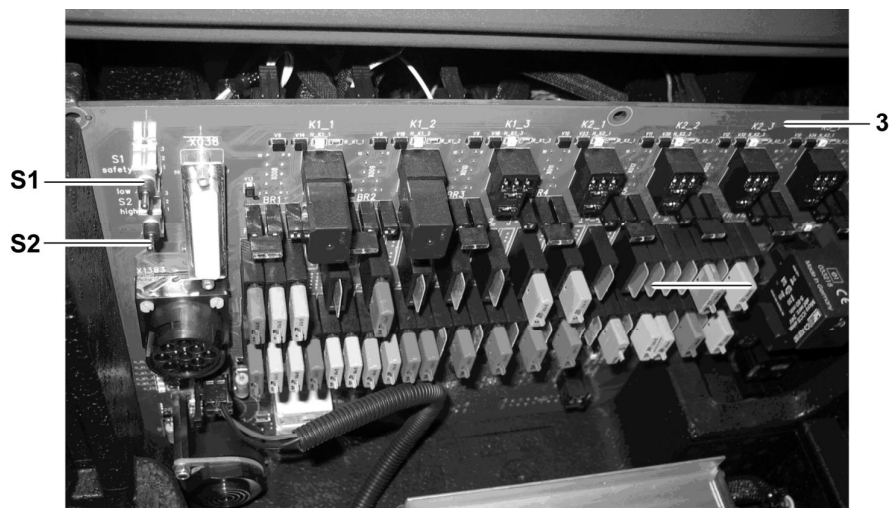













Fig. 608: Main circuit board

- S1 Switch
- S2 Switch
- 3 Main circuit board

LFR/11829208/01/2019-10-18/en

Symbol	Meaning	Effect	Remedy
	Coolant level too low	Damage to diesel engine	Shut off diesel engine. Fill with coolant. If symbol is still displayed, contact Liebherr customer service.
	Warning threshold: Coolant temperature too high	Damage to diesel engine; automatic reduction of diesel engine power	Shut off diesel engine. Reduce load. Fill with coolant. Clean radiator. If symbol is still displayed, contact Liebherr customer service.
	Safety threshold: Coolant temperature too high		
	Air filter contaminated; dust collecting tank full	Damage to diesel engine; automatic reduction of diesel engine power	Empty dust collecting tank. Replace main filter cartridge of air filter.
	Warning threshold: Charge air temperature too high	Damage to diesel engine; automatic reduction of diesel engine power	Clean radiator. If symbol is still displayed, contact Liebherr customer service.
	Safety threshold: Charge air temperature too high		
	Warning threshold: Engine speed too high	Damage to diesel engine	Shut off diesel engine. Contact Liebherr customer service.
	Safety threshold: Engine speed too high	Automatic shut-off of diesel engine	Contact Liebherr customer service.
	Warning threshold: Oil pressure of diesel engine too low	Damage to diesel engine	Shut off diesel engine. Fill with diesel engine oil. If symbol is still displayed, contact Liebherr customer service.
	Safety threshold: Oil pressure of diesel engine too low		
	Warning threshold: Oil pressure of diesel engine too high	Damage to diesel engine	Shut off diesel engine. Correct oil level of diesel engine. Press <i>engine oil level</i> button in <i>measurement display</i> submenu. If symbol is still displayed, contact Liebherr customer service.
	Safety threshold: Oil level of diesel engine too low		

LFR/11829208/01/2019-10-18/en

4.3 Problem remedy

4.3.1 Fuses and relays

Resetting or replacing fuses

**DANGER**

Components under voltage!
Danger to life.

- ▶ Before working on electrical system, switch off battery main switch.
 - ▶ Before working on the electrical system, disconnect batteries from electric circuit.
-

**DANGER**

Bypassed fuses!
Danger to life.

- ▶ Exclusively use genuine fuses.
 - ▶ Do not bypass defective fuses.
-

- ▶ Identify cause of power failure.
- ▶ Repair or replace defective electrical components.
- ▶ Check condition and connection of fuse.

If fuse can be reset and is in good condition:

- ▶ Reset fuse.

or

If fuse is defective:

Replace fuse with original fuse of prescribed current value.

Electric cabinet E50

The electric cabinet E50 is on the partition behind the side door at the front left.

	Current value [A]	Function
F31	20	Air conditioning
F32	10	Roof glass panel windscreen wiper
F33	10	Front windscreen wiper
F34	10	Front windscreen wiper, lower windscreen
F35	15	Radio
Switch fuses on terminal 58 (KL58)		
F23	10	Control unit B
F24	10	Control unit C
F25	10	Control unit D
F26	10	Control unit E
F27	10	Master
Relay		
K01	40	Condenser fan
K02	40	Front roof light
K03		Rear roof light
K04	15	Front windscreen wiper
K05	15	Roof glass panel windscreen wiper
K06	15	Front windscreen wiper, lower windscreen
K07		Rear windscreen wiper
K08	15	KL58
K09	15	Radio
K10		Emergency mode
K11		Warning sound in emergency mode on malfunction of engine
K1_1	15	Option
K1_2	15	Option
K1_3	15	Option
K2_1	15	Option
K2_2	15	Option
K2_3	15	Option
K3_1	15	Option
K3_2	15	Option
K3_3	15	Option

Tab. 59: Fuses and relays of main circuit board

Main fuses

The main fuses are under a protective plate behind the left rear side door.

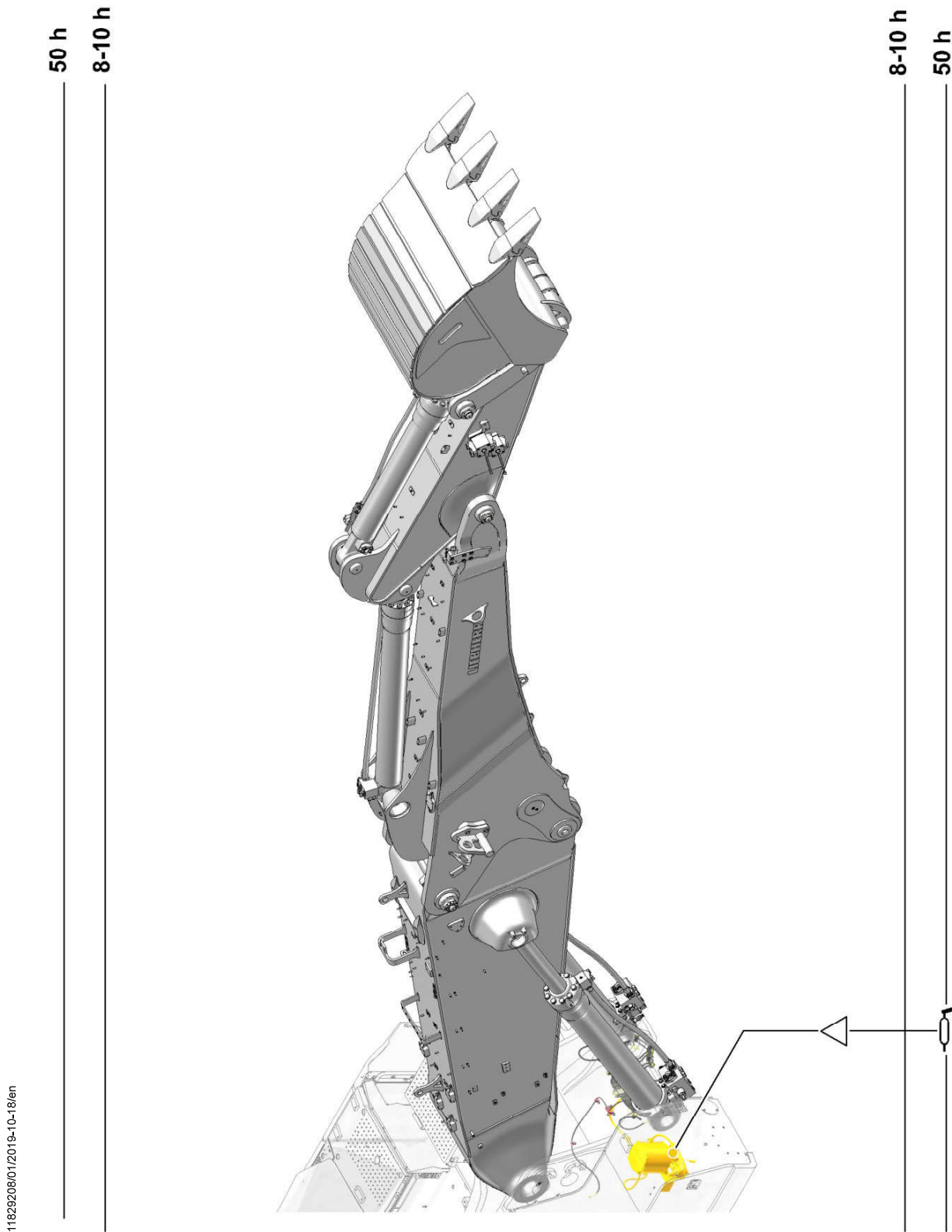

LFR/11829208/01/2019-10-18/en

Fig. 688: Lubrication chart for working attachment in case of central lubrication system

Anti-freeze and corrosion protection agent

Liebherr recommendation

Type	Description
Concentrate	Liebherr-Antifreeze OS Concentrate
Premix ^{A)}	Liebherr-Antifreeze OS Mix

Tab. 79: Liebherr recommendation

Ambient temperature	Mixing ratio
down to -58 °F	40 % water 60 % anti-freeze and corrosion protection agent
down to -35 °F	50 % water 50 % anti-freeze and corrosion protection agent

Tab. 80: Mixing ratio

A) Premix = ready-mixed product (50% water and 50% anti-freeze and corrosion protection agent)

Minimum quality requirements

Specification
LH-01-COL3A

Tab. 81: Minimum quality requirements

If coolants from other manufacturers are used, information on change intervals must be obtained from respective manufacturer or supplier.

5.3.6 Hydraulic oils

Liebherr recommendation

Ambient temperature	Description
	Liebherr mineral oil
59 to 131 °F	Liebherr Hydraulic Basic 100
50 to 113 °F	Liebherr Hydraulic Basic 68
-4 to 104 °F	Liebherr Hydraulic HVI
	Liebherr-PAO ²⁶⁾ biodegradable
-13 to 113 °F	Liebherr Hydraulic Plus
-40 to 86 °F	Liebherr Hydraulic Plus Arctic

Tab. 82: Liebherr recommendation

²⁶⁾ PAO = poly-alpha-olefin

5.5 Preparing for maintenance

5.5.1 Maintenance procedures

Definition of maintenance tasks



Note

Put machine in maintenance position before beginning maintenance tasks.

Following maintenance tasks are defined:

- Lubricate complete machine.
- Check complete machine for cracks.
- Change fuels and operating fluids.
- Replace filter.
- Clean components.
- Check hydraulic system.
- Perform visual inspection for defects.

Definition of visual inspection

Symbol	Meaning
	Visual inspection Indicates places to be examined by visual inspection.

Tab. 98: Symbol of visual inspection

Visual inspection is a visual inspection process of the complete machine and individual components.

The legal basis for visual inspection is provided by DIN EN 13018 or country-specific standards, ordinances and regulations.

Visual inspection without aids

Criteria for the visual inspection without aids are:

- An uninterrupted optical path between the eyes of the inspector and the inspected surface.
- Examination of the complete machine and individual components with the naked eye.

Visual inspection with aids

Criteria for the visual inspection with aids are:

- An interrupted optical path between the eyes of the inspector and the inspected surface.
- Examination of the complete machine and individual components with suitable aids such as mirrors, magnifiers and lighting.

Operating conditions

In general the locally applicable legal regulations must be adhered to. The conditions for storing and application must be adapted to the locally applicable regulations and to the product data sheets. Personal protective equipment must correspond to the list in the safety data sheets. Before chemical products are used, the product data sheets (technical data sheets and safety data sheets) must be read in order to prevent accidents and be able to take appropriate measures in the event of an accident.

Different climatic conditions



Fig. 708: Icy climate



Fig. 709: Polar climate

LFR/11829208/01/2019-10-18/en

5.7 Complete machine

5.7.1 Checking machine for proper condition and tightness

Make sure the following precondition is met:

- Machine is in maintenance position.

5.7.2 Visual inspection before putting into service

NOTICE

Incorrect inspection tour!
Damage to machine.

- ▶ Perform visual inspections as per maintenance and inspection schedule.
 - ▶ Check machine for proper condition.
 - ▶ Check machine for tightness.
 - ▶ Check machine for damage.
-
- ▶ Before putting machine into service, always perform inspection tour.
 - ▶ Perform maintenance tasks as per maintenance and inspection schedule every 8-10 h and 50 h.

5.7.3 Lubricating bearings on machine and working attachment

Lubricating bearings through central lubrication system

The following lubricating points are connected to central lubrication system:

- Lubricating points on basic boom
- Lubricating points on boom
- Lubricating points on stick

The lubricant quantity depends on the following factors:

- Viscosity of grease
- Connected components

NOTICE

Too little lubrication!
Damage to bearings.

- ▶ Make sure that grease emerges at all lubricating points.

If no grease emerges:

- ▶ Change lubrication mode.
 - ▶ Check lubrication lines.
-

Sample document

- ▶ Separate sample document from sample data sheet and store it.



- ▶ Wait until regeneration has finished.

When regeneration is completed:

- *High exhaust temperature* status symbol disappears.
- *Manual activation of regeneration* key returns to its original state.
- ▶ Lower safety lever.
 - ▷ Machine can be used as normal.

Activating manual regeneration after extended downtime

Manual regeneration is required at the specified intervals.

Fuel used	Maximum duration of the extended period without operation
DIN EN 590	12 months
ASTM D975 (89a)	3 months

Tab. 117: Manual regeneration after extended downtime

When maximum duration of extended downtime is reached:

- ▶ Activate the manual regeneration. (For more information see: [Activating the manual regeneration, page 380](#))

Blocking regeneration

NOTICE

Incorrect blocking of regeneration!
Accelerated wear of diesel particulate filter.

- ▶ Exclusively block regeneration in enclosed space or if there is a fire hazard.

Blocking regeneration selectively



- ▶ Select *diesel particulate filter* menu.
- ▶ Press *selective blocking of regeneration* button.
 - ▷ *Selective blocking of regeneration* button appears in green.
 - ▷ *Manual activation of regeneration* button is inactive.
 - ▷ *Regeneration of diesel particulate filter blocked* status symbol appears on the display.
- ▶ Release blocking of regeneration: Press *selective blocking of regeneration* button.
 - ▷ *Selective blocking of regeneration* button appears in white.
 - ▷ *Manual activation of regeneration* button is active.
 - ▷ *Regeneration of diesel particulate filter blocked* status symbol disappears.
- ▶ Blocking of selective regeneration is automatically removed during shut-off.

Blocking regeneration permanently³¹⁾

- ▶ Select *diesel particulate filter* menu.

- ▶ Fill hydraulic tank via return filter **4** until required hydraulic oil level is reached.
- ▶ Screw in breather filter **2**.
- ▶ Fill return filter **4** to the brim.
- ▶ Put on return filter cover **4**.

Checking

- If hydraulic oil is approximately 68 °F:
- ▶ Check hydraulic oil level.

5.10.3 Hydraulic tank: Draining water and sediments

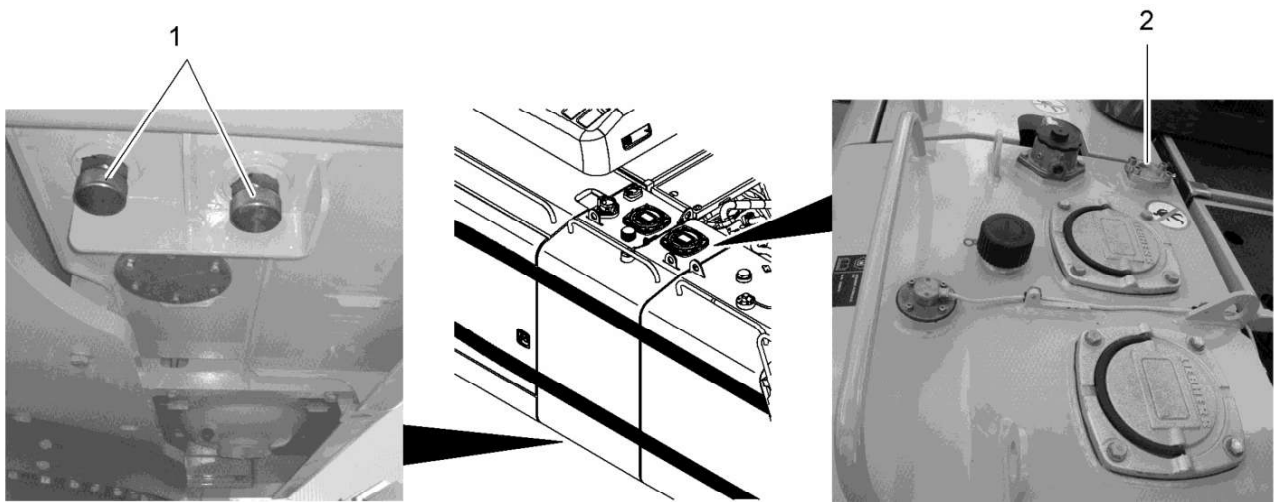

Fig. 758: Hydraulic tank

1 Drain valve

2 Collecting pipe



Note

If biodegradable hydraulic oil is used:

- ▶ After every diesel engine downtime exceeding 24 hours, drain water and sediment from hydraulic tank.
-
- ▶ Depressurise hydraulic system.
 - ▶ Place suitable receptacle under hydraulic tank.
 - ▶ Remove SAE dummy flange of collecting pipe **2**.
 - ▶ Unscrew plugs of drain valves **1**.
 - ▶ Attach drain hoses supplied with machine to drain valves **1** under hydraulic tank.
 - ▶ Drain water and sediments until clean hydraulic oil emerges.
 - ▶ Remove drain hoses.
 - ▶ Screw in plugs of drain valves **1**.
 - ▶ Mount SAE dummy flange of collecting pipe **2**.

5.15 Lubrication system

5.15.1 Lubrication system (option): Topping up grease

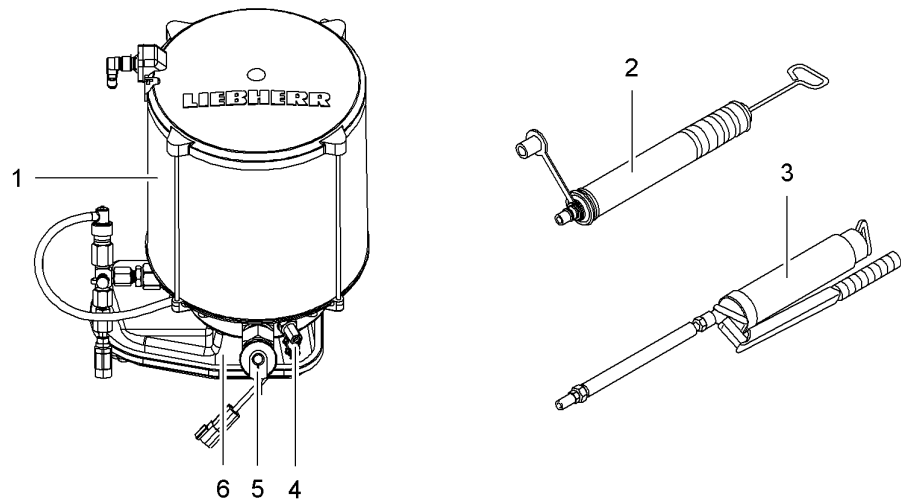

Fig. 775: Lubrication system: Topping up grease

1	Grease container	4	Grease fitting
2	Filling pump	5	Filling pump adapter
3	Grease gun	6	Lubricating pump

NOTICE

Incorrect filling of grease!
Damage.

- ▶ Regularly check fill level of grease container.
- ▶ Exclusively fill with grease via filling pump adapter or grease fitting.

- Grease used is approved.
- ▶ Insert grease cartridge in filling pump 2.
- ▶ Connect filling pump 2 to filling pump adapter 5.
- ▶ Press content of grease cartridge into grease container 1.

If no filling pump 2 is available:

- ▶ Fill in grease with grease gun 3 via grease fitting 4.

5.15.2 Checking lubrication of bearings (grease collar)

- ▶ Check all connected lubricating points for sufficient lubricant distribution.

CLICK HERE TO **DOWNLOAD** THE COMPLETE MANUAL

- Thank you very much for reading the preview of the manual.
- You can download the complete manual from: www.heydownloads.com by clicking the link below



- Please note: If there is no response to CLICKING the link, please download this PDF first and then click on it.

CLICK HERE TO **DOWNLOAD** THE COMPLETE MANUAL