

en

Operator's manual

Machine for Industrial Applications

LH 50 M HR Litronic

From serial number 51023

Document ID

	ORIGINAL OPERATOR'S MANUAL
Order number:	11645668
Issued:	2015-12-15
Version:	01
Author:	LHB / Technical Documentation Department

Product ID

Manufacturer:	Liebherr-Hydraulikbagger GmbH
Type:	LH 50 M HR Litronic
Type no.:	1203
From Serial no.:	51023

Conformity:



Contact

Liebherr-Hydraulikbagger GmbH
Liebherrstraße 12
D – 88457 Kirchdorf/Iller

CLICK HERE TO **DOWNLOAD** THE COMPLETE MANUAL

- Thank you very much for reading the preview of the manual.
- You can download the complete manual from: www.heydownloads.com by clicking the link below



- Please note: If there is no response to CLICKING the link, please download this PDF first and then click on it.

CLICK HERE TO **DOWNLOAD** THE COMPLETE MANUAL

3.2.15	Cab lighting system	78
3.2.16	Beacon (option)	79
3.2.17	Windshield wipers	80
3.2.18	Windscreen washer system	80
3.2.19	Display	81
3.2.20	Status symbols	82
3.2.21	Main menu	95
3.2.22	Camera system menu	96
3.2.23	Automatic heating and automatic ventilation	97
3.2.24	Automatic air conditioning	100
3.2.25	Operating status menu	104
3.2.26	General settings menu	104
3.2.27	Machine-specific settings menu	111
3.2.28	Information menu	118
3.2.29	Tool Control menu	121
3.2.30	Messages menu	121
3.2.31	Auxiliary heater (option)	122
3.2.32	Drink holder	123
3.2.33	Radio system	123
3.2.34	LiDAT (option)	126
3.3	Operation	127
3.3.1	Inspection tour before putting into service	127
3.3.2	Refuelling	128
3.3.3	Fuelling with electric refuelling pump (option)	128
3.3.4	Preheating system (option)	130
3.3.5	Immobiliser (option)	132
3.3.6	Preparing machine for dust intensive application	133
3.3.7	Preparing machine for use in biologically sensitive areas	134
3.3.8	Starting diesel engine	134
3.3.9	Bringing machine to operating temperature	135
3.3.10	Engine speed and operating mode	135
3.3.11	After starting	137
3.3.12	Sensor-controlled low idle automatic	139
3.3.13	Automatic engine shut-off after idling (option)	139
3.3.14	Shutting off the diesel engine	140

1.1.4 Energy recuperation cylinder (option)

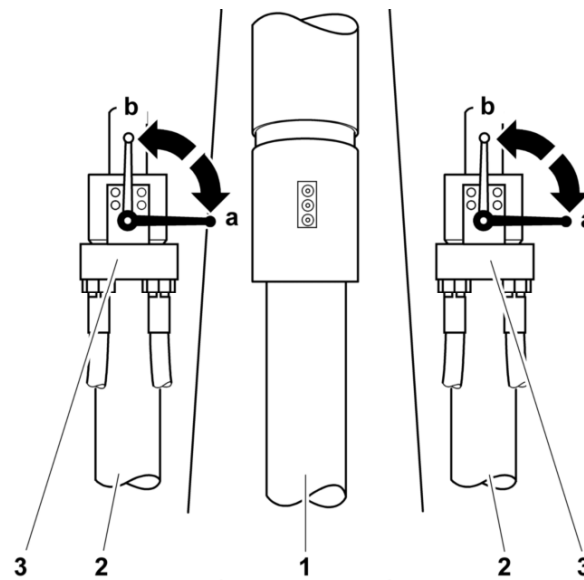

Fig. 5: Block type ball valve on the hoist cylinders

- | | | | |
|---|------------------------------|---|------------------------------|
| 1 | Energy recuperation cylinder | a | Block type ball valve closed |
| 2 | Hoist cylinder | b | Block type ball valve open |
| 3 | Block ball cock | | |

Energy recuperation cylinder (ERC) is a pressure vessel filled with gas, which supports the hoisting movement of boom. This system can be identified in the form of a third cylinder between the hoist cylinders.

When developing the energy recuperation system, which was specially designed for material handling machines, focus was on the overall efficiency of hydraulic system and efficiency of machine. In real operation this means an increase in energy efficiency and more consistent operating cycles.

The energy recuperation system works on the operating principle that gas stored in the energy recuperation cylinder is compressed when the attachment is lowered. The saved energy supports the two hoist cylinders when lifting.

Outside temperature differences may lead to pressure fluctuations inside energy recuperation cylinder. This may result in reduced load lift values as well as inadvertent retraction or extension of energy recuperation cylinder and resulting movement of boom.

To prevent unintentional extension and boom movements, the energy recuperation cylinder must be locked when exiting the machine. This is done with the help of two block type ball valves installed on the hoist cylinders. The block type ball valves must be closed when exiting the machine. Unlike the hydraulic system, the energy recuperation cylinder is still completely pressurised.

Attachment AF18 (Kinematic 2D)

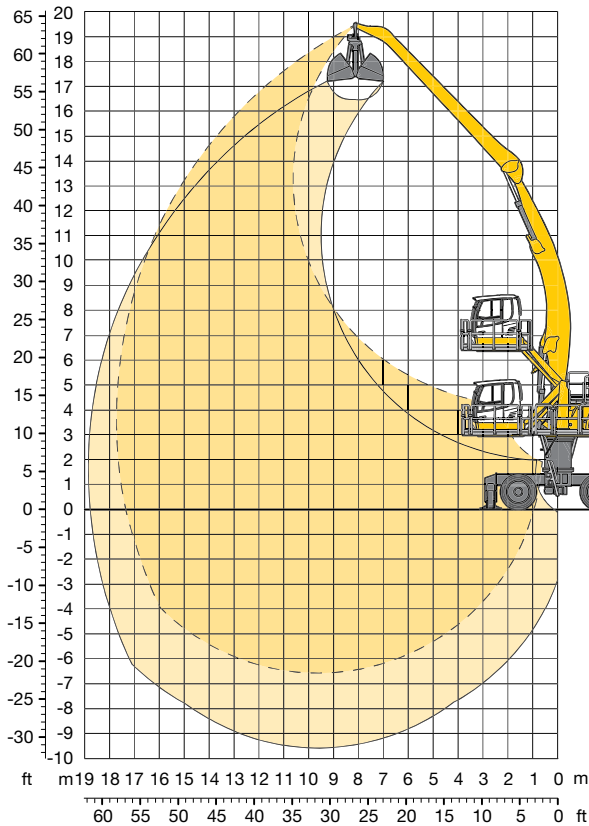

Operating Weight

The operating weight includes basic machine with 4 point outriggers, turret 1.20 m, hydr. cab elevation, 4 solid tires, industrial-type angled mono boom 9.60 m and industrial-type flat angled stick 9.00 m.

with clamshell model GM 20B/1.50 m³
shells for loose material

46,850 kg

Dimensions

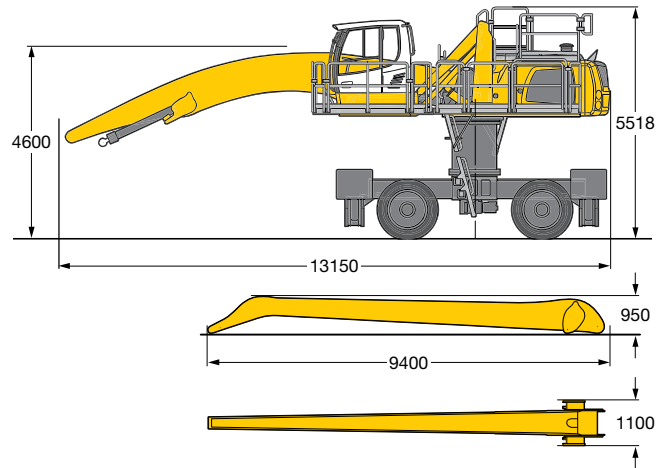

Industrial Stick 9.00 m

m	Undercarriage	3.0 m		4.5 m		6.0 m		7.5 m		9.0 m		10.5 m		12.0 m		13.5 m		15.0 m		16.5 m		18.0 m		m		
		3.0	3.0	4.5	4.5	6.0	6.0	7.5	7.5	9.0	9.0	10.5	10.5	12.0	12.0	13.5	13.5	15.0	15.0	16.5	16.5	18.0	18.0	3.7	3.7	10.5
18.0	4 pt. outriggers down											3.7*	3.7*											3.7*	3.7*	10.5
16.5	4 pt. outriggers down											4.9*	4.9*	3.7*	3.7*									3.3*	3.3*	12.3
15.0	4 pt. outriggers down											5.0*	5.0*	4.6*	4.6*	3.4*	3.4*							3.1*	3.1*	13.7
13.5	4 pt. outriggers down													4.6*	4.6*	4.3*	4.3*							3.0*	3.0*	14.8
12.0	4 pt. outriggers down													4.6*	4.6*	4.3*	4.3*	3.8*	3.8*					2.9*	2.9*	15.7
10.5	4 pt. outriggers down											5.0*	5.0*	4.6*	4.6*	4.3*	4.3*	4.0*	4.0*					2.9*	2.9*	16.4
9.0	4 pt. outriggers down										6.0*	6.0*	5.2*	5.2*	4.7*	4.7*	4.3*	4.3*	4.0*	4.0*	3.6*	3.6*		2.8*	2.8*	17.0
7.5	4 pt. outriggers down									6.0*	6.0*	5.4*	5.4*	4.8*	4.8*	4.4*	4.4*	4.1*	4.1*	3.8*	3.8*		2.9*	2.9*	17.4	
6.0	4 pt. outriggers down							7.4*	7.4*	6.3*	6.3*	5.6*	5.6*	5.0*	5.0*	4.5*	4.5*	4.2*	4.2*	3.8*	3.8*		2.9*	2.9*	17.6	
4.5	4 pt. outriggers down			12.8*	12.8*	9.8*	9.8*	7.9*	7.9*	6.7*	6.7*	5.8*	5.8*	5.2*	5.2*	4.6*	4.6*	4.2*	4.2*	3.8*	3.8*		3.0*	3.0*	17.7	
3.0	4 pt. outriggers down	5.5*	5.5*	14.6*	14.6*	10.7*	10.7*	8.5*	8.5*	7.1*	7.1*	6.1*	6.1*	5.3*	5.3*	4.7*	4.7*	4.3*	4.3*	3.9*	3.9*		3.1*	3.1*	17.7	
1.5	4 pt. outriggers down	3.0*	3.0*	7.9*	7.9*	11.4*	11.4*	8.9*	8.9*	7.4*	7.4*	6.3*	6.3*	5.5*	5.5*	4.8*	4.8*	4.3*	4.3*	3.8*	3.8*		3.2*	3.2*	17.6	
0	4 pt. outriggers down	3.1*	3.1*	5.9*	5.9*	11.8*	11.8*	9.2*	9.2*	7.6*	7.6*	6.4*	6.4*	5.5*	5.5*	4.8*	4.8*	4.3*	4.3*	3.7*	3.7*		3.4*	3.4*	17.3	
-1.5	4 pt. outriggers down	3.6*	3.6*	5.6*	5.6*	9.8*	9.8*	9.3*	9.3*	7.6*	7.6*	6.4*	6.4*	5.5*	5.5*	4.8*	4.8*	4.2*	4.2*	3.5*	3.5*		3.3*	3.3*	16.9	
-3.0	4 pt. outriggers down	4.1*	4.1*	5.8*	5.8*	9.1*	9.1*	9.1*	9.1*	7.5*	7.5*	6.3*	6.3*	5.4*	5.4*	4.6*	4.6*	3.9*	3.9*				3.1*	3.1*	16.4	
-4.5	4 pt. outriggers down			6.2*	6.2*	9.1*	9.1*	8.4*	8.4*	7.0*	7.0*	5.9*	5.9*	5.0*	5.0*	4.2*	4.2*	3.3*	3.3*				3.1*	3.1*	15.3	
-6.0	4 pt. outriggers down							7.4*	7.4*	6.2*	6.2*	5.2*	5.2*	4.3*	4.3*								3.9*	3.9*	12.7	
-7.5	4 pt. outriggers down																									

Height Can be slewed through 360° In longitudinal position of undercarriage Max. reach * Limited by hydr. capacity

The lift capacities on the stick end without attachment are stated in metric tons (t) and are valid on a firm, level supporting surface with blocked oscillating axle. These capacities can be slewed through 360° with the undercarriage in the transverse position. Capacities in the longitudinal position of the undercarriage (+/- 15°) are specified over the steering axle with the stabilizers raised and over the rigid axle with the stabilizers down. Indicated loads comply with the ISO 10567 standard and do not exceed 75% of tipping or 87% of hydraulic capacity. The lift capacity values indicated are attained at the corresponding operating temperature. This operating temperature is ensured by continuous movement of the boom. Weights of fitted working tools (grabs, load hooks, etc.) and load accommodation equipment are to be deducted from the lift capacity values. The lift capacity of the unit is limited by its stability, the lifting capability of the hydraulic elements, or the maximum permissible lifting capacity of the load hook. In accordance with the harmonised European Standard EN 474-5, hydraulic excavators used for lifting operations must be equipped with pipe fracture safety valves, an overload warning device, a load hook and a lift capacity chart.

The manufacturer is not liable for damage attributable to use not in accordance with the designated use. The user bears sole responsibility.

2.4 Signs on the machine

2.4.1 Warning signs



DANGER

Non-observance of the warning signs!
Consequence may be severe injuries or death!

- ▶ Check that all warning signs are in place and are legible.
 - ▶ Replace immediately signs that are missing or illegible.
-

“Safety belt” sign

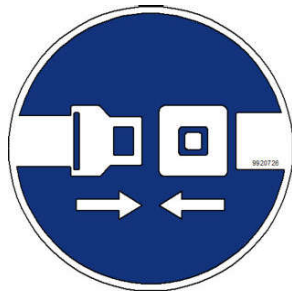

Fig. 15: “Safety belt” sign

Put on the safety belt before taking the machine into operation.

“Hazardous area” sign



Fig. 16: “Hazardous area” sign

Waiting in the danger zone of the machine during operation is prohibited.

“Grease specifications” sign

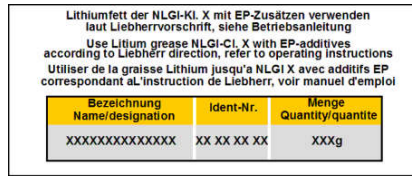

Fig. 42: "Grease specifications" sign

Indicates the specified grease and information in the operator's manual.

“ROPS” sign

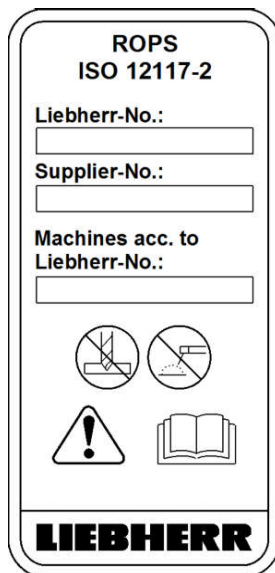

Fig. 43: "ROPS" sign

Identifies the ROPS equipment option.

2.4.3 Control description sticker

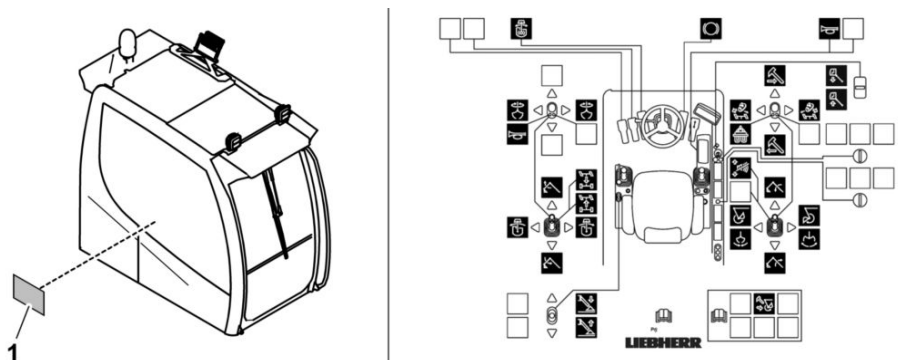

Fig. 44: Control description sticker in the operator's cab, example of control description sticker

1 Control description sticker

LHB/11645668/01/2015-12-15/en

Park the machine on level ground and secure the tracks or wheels using wedges.

If necessary, remove parts of the working attachment for the duration of transport if these exceed the permissible transport dimensions.

Clean the undercarriage. The undercarriage must be swept clean. Before driving onto the transport vehicle, clean the tracks or wheels to remove snow, ice and mud.

Align the machine precisely with the loading ramp.

Tracked travel gear: attach the hand levers for precision movement to the accelerator pedals.

Make sure that a spotter gives the machine operator the necessary signs.

Secure the machine and all individual parts by lashing in accordance with the applicable national regulations.

Pull out the ignition key and move the safety lever upwards before you leave the machine.

Close all doors (operator's cab, covers).

Make sure that no-one is on the machine during the transport.

Prior to the transport, find out about the route to be taken as well as the applicable limits for width, height and weight.

Pay particular attention when passing under power lines and bridges, as well as when passing through tunnels.

Proceed with the same caution when unloading as when loading.

2.5.13 Towing

The machine is only allowed to be towed under exceptional circumstances, e.g. in order to remove the machine from a place of danger in order to take it for repair.

Damage or accidents which occur during towing will never be covered by the manufacturer's warranty.

Before pulling or towing, check that all attachment and towing devices are safe and secure.

Only secure attachment and towing devices to the points provided on the machine for this purpose.

When towing, comply with the prescribed transport position, permitted speed and distance.

When towing, comply with the information given in the operating manual.

2.5.14 Maintenance and repair

Qualification of the personnel

Maintenance and repair work is only allowed to be performed by trained specialist personnel.

Make sure that a sufficiently equipped workshop is available to carry out this work, and that the responsible personnel have the necessary qualifications.

The inspection and maintenance schedule defines precisely who is allowed to or who must perform which jobs.

3.1.2 Control unit A

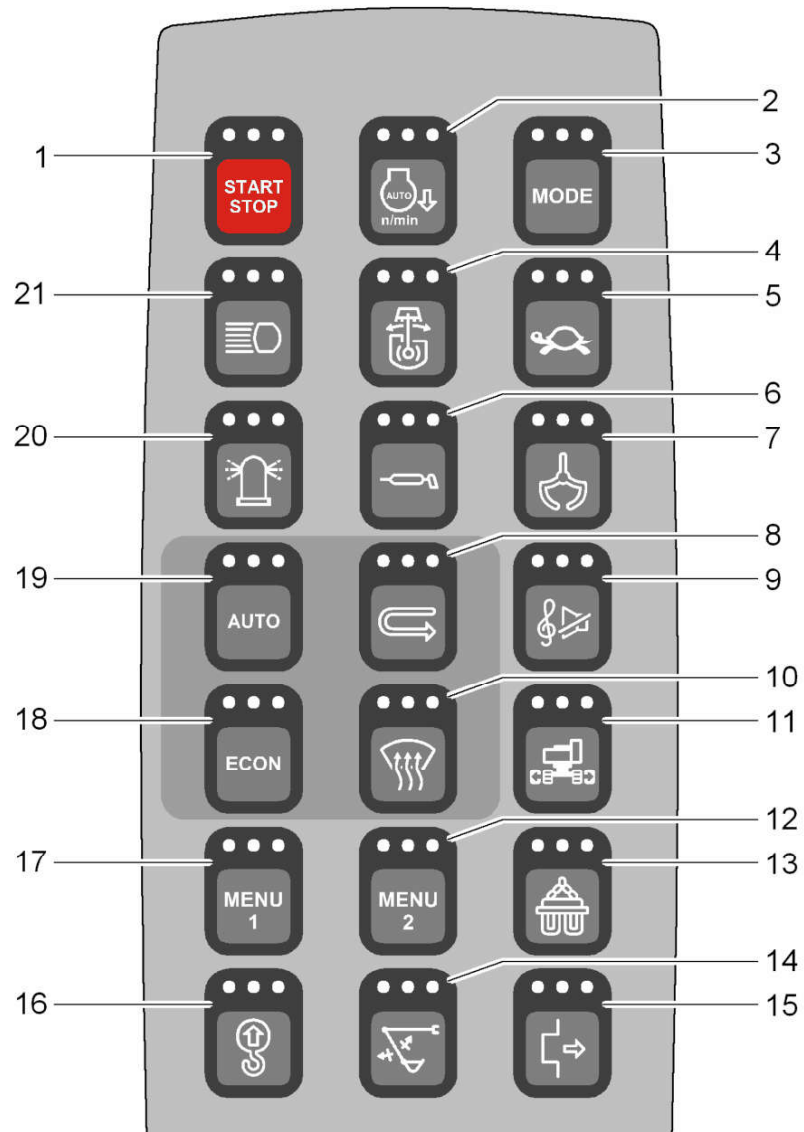

Fig. 47: Control unit A, key assignment

- | | | | |
|---|--------------------------------------|----|---|
| 1 | Engine start / stop | 12 | Quick access menu 2 ⁶⁾ |
| 2 | Sensor-controlled low idle automatic | 13 | Magnet system ³⁾ |
| 3 | MODE (operating mode) ³⁾ | 14 | Bypass stick cylinder shut-off |
| 4 | Slewing gear brake | 15 | Quick change adapter |
| 5 | Creeper gear | 16 | Overload warning system ³⁾ |
| 6 | Central lubrication system | 17 | Quick access menu 1 ⁶⁾ |
| 7 | Grapple circuit ³⁾ | 18 | ECON (operation without cooling function) ⁴⁾ |

See next page for continuation of the image legend

⁶⁾ User-programmable key

³⁾ Option / equipment variant

Setting seat position

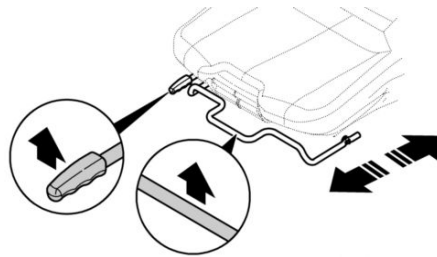

Fig. 64: Setting seat position

Setting seat position with armrests

- ▶ Pull middle lever up.
- ▶ Move operator's seat.
- ▶ Release lever.
 - ▷ Lever engages audibly.
 - ▷ Operator's seat is adjusted.

Setting seat position without armrests

- ▶ Pull outer lever up.
- ▶ Move operator's seat.
- ▶ Release lever.
 - ▷ Lever engages audibly.
 - ▷ Operator's seat is adjusted.

Setting armrest angle

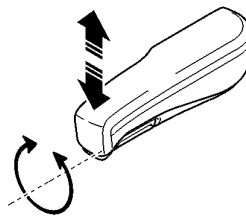

Fig. 65: Setting armrest angle

- ▶ Turn hand wheel on the underside to the right.
 - ▷ Armrest is moved upwards.
- ▶ Turn hand wheel on the underside to the left.
 - ▷ Armrest is moved downwards.

Roof glass panel sun blind

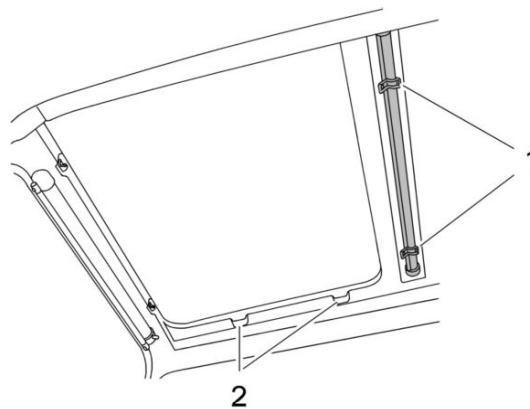

Fig. 82: Roof glass panel sun blind

1 Handles

2 Catches

Rolling out the roof glass panel sun blind

- ▶ Pull the roof glass panel sun blind forward using the handles 1.
- ▶ Clip the roof glass panel sun blind into the catches 2.

Rolling up the roof glass panel sun blind



- ▶ Lift the roof glass panel sun blind out of the catches 2 and roll it back slowly.

3.2.14 Lighting

Key	Status of LEDs	Function
	○ ○ ○	Working attachment headlights off
	○ ○ ☀	Boom headlights light up
	☀ ☀ ☀	Boom and stick headlights light up
	○ ☀ ○	Stick headlights light up
	○ ○ ○	Front operator's cab headlights off
	☀ ☀ ☀	Front operator's cab headlights on

LHB11645668/01/2015-12-15/en

Travelling

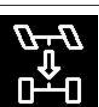
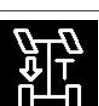
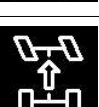
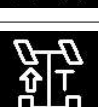
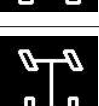
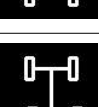
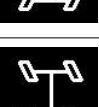
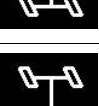
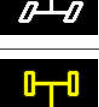
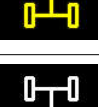
Symbol	Meaning
	Travel speed reduced
	Travel mode blocked
	Travel mode; neutral position required
	Travelling backwards
	Travel backwards with speed controller
	Travelling forward
	Travel forwards with speed controller
	Front steering axle
	Rear steering axle
	Four-wheel steering
	Crab steering
	Align axles straight
	Axles aligned straight

Camera activity indicator

The camera activity indicator **2** indicates the correct display of camera images in real time.

- ▶ Make sure that the bar in the activity indicator is moving.

3.2.23 Automatic heating and automatic ventilation



The temperature in the cab can be set in a range from 16 °C to 28 °C. It is not possible to reach temperatures below the outside temperature.

The ventilation blows fresh air into the cab.

The automatic heating and automatic ventilation functions optimally under the following conditions:

- Diesel engine is running.
- Automatic mode is switched on.
- Windows and doors are closed.
- Air outlets are opened.

The colour of the buttons in the display show whether the function is active.

Display	Meaning
	Function not active
	Function active

Tab. 23: Example representation for all buttons



CAUTION

Fogged up windows!
Restricted visibility.

- ▶ Do not switch on recirculated air mode for long periods.

The light sensor for sunlight is on the rear of the display.

Make sure the following preconditions are met:

- Light sensor is not covered.
- Light sensor is not damaged.

Teleservice

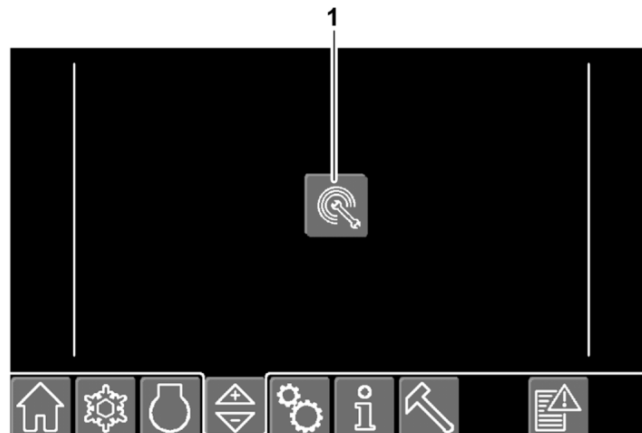

Fig. 301: Teleservice menu

1 Teleservice button

Through teleservice, Liebherr customer service has read/write access so that it can read and modify the machine control parameters online.

Activating write access



DANGER

Unexpected movement of machine!
Danger to life.

- ▶ Make sure that no-one is in working area of machine.



Note

Malfunctions in machine control!

- ▶ Do not operate machine during write access by Liebherr customer service.



- ▶ Press *teleservice 1* button when asked to do so by Liebherr customer service.
 - ▷ *Teleservice 1* button is displayed in green:



- ▷ *Teleservice active* symbol is displayed:



- ▷ Online connection is enabled.
- ▷ Liebherr customer service has write access to machine control parameters.

Deactivating write access

Write access is disconnected by Liebherr customer service.

Bleeding hydraulic circuit menu

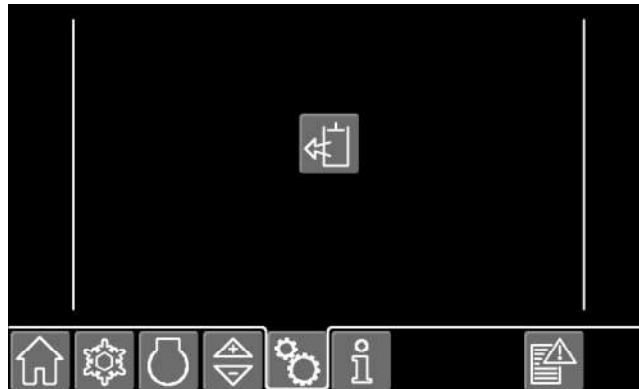

Fig. 331: Bleeding hydraulic circuit menu

When function is activated, no fuel is injected. The diesel engine is rotated by starter but will not start. By rotating flange-mounted pumps it is possible to bleed oil circuits.

Automatic reversing fan drive menu (option)

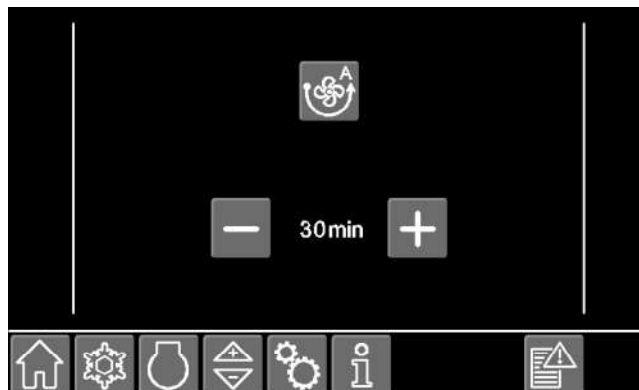

Fig. 332: Automatic reversing fan drive menu

- ▶ Activate automatic reversing fan drive: (For more information see: [3.3.33 Reversing fan drive for radiator cleaning \(option\)](#), page 165)

3.3 Operation

3.3.1 Inspection tour before putting into service

- ▶ Before putting machine into service, always perform inspection tour.
- ▶ Secure the machine before the inspection tour to prevent rolling away.
- ▶ Make sure there is free access to areas that have to be checked.
- ▶ Carry out inspection tour according to the following schedule.

Checkpoint	Activity
Overall status	Check the machine for loose pins, cracks, wear, damage and tightness. Never put defective machine into service. Have damage repaired immediately.
Warning signs	Check the warning signs for completeness and readability. Replace damaged signs. Replace unreadable signs.
Protective devices and safety devices	Check completeness and function of protective devices and safety devices (for example safety belt, mounting of pressure sensors and angle sensors).
Intake area	Clean engine bonnet and uppercarriage in the area of cooling air and combustion air intake to remove dirt, ice and snow.
Window panes and mirrors	Clean contaminated window panes and mirrors. Adjust mirrors. Check fill level of windscreen washer system. Check antifreeze concentration.
Doors and covers	Close all hoods, covers and doors. Do not lock hoods, covers and doors, so that the source of any fire can be accessed quickly. Secure windows against inadvertent movements.
Diesel engine	Check oil level.
Cooling system	Check coolant level. Check radiator for damage. Clean contaminated radiator.
Fuel system	Check fuel lines for damage and tightness. Drain water from fuel pre-filter.
Hydraulic system	Check oil level. Check hydraulic lines for damage and tightness.
Energy recuperation cylinder ^{B)}	Open the block type ball valves on the hoist cylinders. (For more information see: 1.1.4 Energy recuperation cylinder (option), page 21)
Tyres ^{A)}	Check tyres for damage. Check wheel nuts for completeness and mounting. Check tyre pressure. Check tread depth. Have defects repaired immediately.
Travel gear ^{A)}	Check the travel gear for damage, missing or loose parts. Have defects repaired immediately.
Persons in the danger zone	Make sure no-one is working on machine in the danger zone of the machine. Sound horn to warn bystanders before starting machine. Do not start operation if people do not leave danger zone in spite of being warned.
Climbing facilities	Have missing steps, railings and handles renewed. Have defective steps, railings and handles replaced. Clean contaminated, slippery climbing facilities.

Tab. 27: Inspection tour

A) depending on travel gear type

B) Option

LHB11645668/01/2015-12-15/en

CLICK HERE TO **DOWNLOAD** THE COMPLETE MANUAL

- Thank you very much for reading the preview of the manual.
- You can download the complete manual from: www.heydownloads.com by clicking the link below



- Please note: If there is no response to CLICKING the link, please download this PDF first and then click on it.

CLICK HERE TO **DOWNLOAD** THE COMPLETE MANUAL

Operating mode P+

Operating mode P+ corresponds to speed step 10+. Operating mode P+ can exclusively be selected with *engine speed* controller.

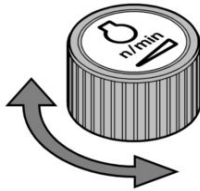

- ▶ Select operating mode P+: Turn *engine speed* controller to right.
 - ▷ Operating mode appears on display.
 - ▷ LEDs of *MODE* key display selected operating mode.
- ▶ Deselect operating mode P+: Press *MODE* key.
 - or
 - Turn *engine speed* controller to left.

Engine speed and operating mode after starting machine

After starting the machine speed step 1 is preset.

In *Mode* key LEDs for the most recently activated operating mode flash.

- ▶ Enter most recently activated operating mode: Press *MODE* key.
 - or
 - Select operating mode S, E and P: Press *MODE* key until required operating mode is active.
 - or
 - Select operating mode P+: Turn *engine speed* controller.

3.3.11 After starting

Operating the machine



DANGER

Risk of suffocation due to exhaust fumes when the engine is run inside buildings.

- ▶ Do not run the engine in enclosed rooms unless there is adequate ventilation.
- ▶ Open the doors and windows of the building in order to ensure an adequate fresh-air supply.



WARNING

Low oil temperatures have the effect of the control system operating sluggishly. Risk of accidents if the functional check is not carried out.

- ▶ Before exposing the machine to full load, bring the engine and hydraulic oil to operating temperature.
- ▶ Carefully drive the machine onto open ground and check all safety-relevant functions.

3.3.17 Selecting the operating mode of the oscillating axle

Locking the oscillating axle

The oscillating axle (the steering axle) can be operated in oscillating mode (unlocked) or rigid (locked), depending on the application. The function is adjusted with the *oscillating axle switch*.

When unlocked, the oscillating axle can move and is able to adapt to irregularities in the ground. When locked, the oscillating axle cannot be moved, which increases the stability of the machine but makes it unable to adapt to irregularities in the ground.

The oscillating axle switch determines the operating mode of the oscillating axle.



DANGER

Unlocking the oscillating axle reduces the stability of the machine! The oscillating axle support automatic (switch setting A) unlocks the oscillating axle when the operating brake is released!

Selecting the wrong operating mode could result in you being surprised by the sudden flexure of the oscillating axle! The machine can fall over when carrying a suspended load! Danger of accidents!

Before working, or before attempting to move the machine with a suspended load:

- ▶ Lock the oscillating axle.

When using the oscillating axle support automatic:

- ▶ Only release the operating brake for load-free travelling when the working attachment is free from load.

Oscillating axle switch	Switch setting	Operating mode	Application
		Oscillating axle unlocked	Travelling without load
		Oscillating axle locked	Working or driving with a suspended load (load on the working attachment, tool attachment)
	A	Oscillating axle support automatic; locking the operating brake locks the oscillating axle. Releasing the operating brake unlocks the oscillating axle.	Working, travelling without load

Tab. 34: Operating modes of the oscillating axle

Symbol	Explanation
	Oscillating axle locked
	Oscillating axle support automatic, oscillating axle locked

LHB11645668/01/2015-12-15/en

In a machine with energy recuperation cylinder and short or light attachment, the intrinsic weight of boom is not sufficient to overcome the lifting force of energy recuperation cylinder. Boom is not lowered, or not lowered evenly.

- ▶ Stop attachment movements.
- ▶ Pay attention to control description sticker in operator's cab. ([For more information see: 2.4.3 Control description sticker, page 37](#))
- ▶ Press *active boom lowering* key.
or
- ▶ Press button on left joystick.
 - ▷ "Active boom lowering" operating mode is active.
 - ▷ Boom is lowered hydraulically.

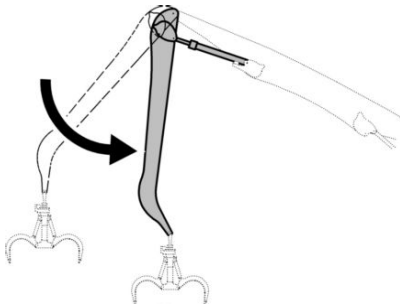

3.3.25 Lowering stick actively (option)

In "passive stick lowering" operating mode, stick moves downwards exclusively under its own weight. This reduced energy consumption and leaves a greater power reserve in the hydraulics for other movements.

In the "passive stick lowering" operating mode, the stick can exclusively be lowered to the lowest point, at which the stick is approximately vertical. If the stick should be retracted further, the operating mode must be changed to "active stick lowering".

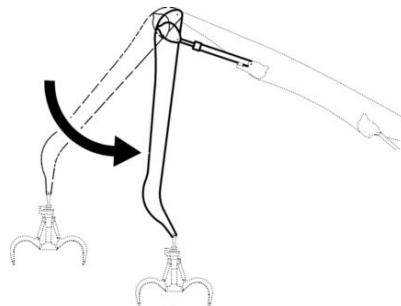

Fig. 453: Possible stick movement in "passive stick lowering" operating mode

- ▶ Stop attachment movements.
- ▶ Press *active stick lowering* key.



- ▷ The LEDs in the key light up.
- ▷ "Active stick lowering" operating mode is active.
- ▷ The stick is retracted hydraulically.

3.3.26 Selecting the working tool

The machine can move working tools with various pressure settings and flow settings. The settings for working tools are listed in the *Tool Control* menu.

3.4 Shut-down and limitation devices

3.4.1 Stick cylinder shut-off (option)

The working attachment with suspended load can collide with the machine, the operator's cab or obstacles in the vicinity. This can lead to accidents due to inattention by the operator.

To support the operator, the permitted working area of the working attachment can be limited by the stick cylinder shut-off.

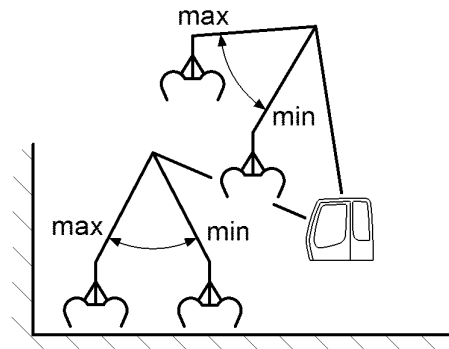

Fig. 496: Shut-off points: Move in stick (min), move out stick (max)

Activating the stick cylinder shut-off and setting the shut-off points are performed in the "machine-specific settings/setting the stick cylinder shut-off" menu.

The specifications are given in % of possible deflection.

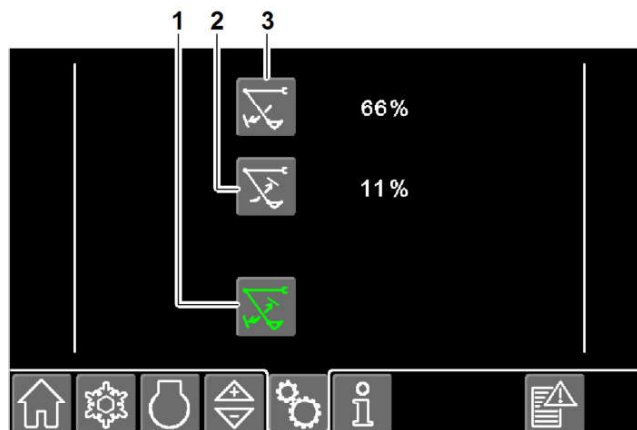

Fig. 497: Stick cylinder shut-off menu

- | | | | |
|---|--------------------------------|---|-----------------------|
| 1 | Stick cylinder shut-off On/Off | 3 | Outer shut-off point |
| 2 | Inner shut-off point | 4 | Confirmation required |



- ▶ Press confirmation button within 5 seconds.
 - ▷ *Height limitation* button lights up white:



Troubleshooting

Height limitation not switched off?

If confirmation button is not pressed within 5 seconds, height limitation remains switched on.

- ▶ Switch off height limitation again.
-

Teaching in maximum height limitation value



DANGER

High voltage!
Danger to life.

If an overhead power line restricts the height:

- ▶ Set maximum height limitation value exclusively by hand.
-



DANGER

Height limitation setting incorrect!
Danger to life.

- ▶ Set the height limitation value so that swinging working tools do not collide with obstacles.
-

The limit value of the maximum working height **3** is set at 3.50 m when the machine is started.

Make sure the following preconditions are met:

- Machine is lifted to the maximum with the support.
- Working tool operating mode is selected.
- Bucket cylinder shut-off is set. (For more information see: [Setting bucket cylinder shut-off, page 183](#))
- Supervisor supervises setting of maximum working height.
- ▶ Insert authorisation key in key switch.
- ▶ Turn key to right into enabled position.
- ▶ Switch on height limitation. (For more information see: [Switching on height limitation, page 176](#))

If new maximum working height is higher than previously set maximum working height:

- ▶ Bypass height limitation. (For more information see: [Bypassing height limitation, page 185](#))
- ▶ Move working attachment up to limit value of maximum permitted working height.

3.5 General working methods

3.5.1 Safety belt

The probability of surviving an accident increases if the safety belt is fastened. The safest place in an accident is the protective operator's cab, with the safety belt fastened.

Many severe and fatal injuries are due to the operator not having the seat belt fastened and attempting to jump out of the operator's cab in case of an accident. In the majority of cases, it is better to remain in the operator's cab.

The accident prevention instructions demand that a safety belt must be fastened, and that it must be serviced and checked regularly.

3.5.2 Drugs and alcohol

Safe operation of large and powerful machinery is significantly dependent on the performance of the operator. Alcohol and drugs affect sensory perception. They slow reaction times, reduce attentiveness and make it more difficult to detect problematic situations.

The consumption of alcohol and drugs not only endangers the operator himself, but also everyone else at the place of use. Misuse of alcohol and drugs can have severe or fatal consequences and lead to damage. Do not work under the influence of alcohol or drugs.

3.5.3 Working without damaging the machine

Comply with the following points in order to increase the service life of the machine and to avoid unnecessary damage and the need to carry out repairs as a result:

- Repeated striking of the working attachments against hard material will lead to damage to the machine. Do not use the working attachment to strike against material or objects to be demolished.
- Certain combinations of boom, stick and working tool mean that the working tool can strike against or penetrate the operator's cab. This can damage the operator's cab and injure the machine operator.
- The slewing gear can be damaged if the rotary motion is obstructed by an opposing force. Do not use the slewing gear to force the working attachment to penetrate material.
- The machine can be damaged by being raised using the working attachment. Do not lift the machine using the working attachment. If this does happen inadvertently nevertheless, lower the machine slowly onto the ground. Do not allow the machine to drop quickly, and do not attempt to cushion the drop using the hydraulics.

3.8 Transport and assembly













Normally, the machine is only fully assembled at the place of use. The individual working steps are performed in accordance with Liebherr assembly guidelines.

Assembly, disassembly and transport are only allowed to be carried out by trained specialist personnel from Liebherr, or by partners authorised by Liebherr.

Contact the responsible customer service if the machine is to be transported or converted.

If the machine has to be transported or converted:

- ▶ Contact the Liebherr customer service.

Symbol	Meaning	Effect, characteristic	Remedy
	Prewarning: Oil level of diesel engine is low.	Diesel engine is damaged.	Shut off diesel engine. Fill with diesel engine oil. If symbol is still displayed: Contact Liebherr customer service.
	Oil level of diesel engine is too low.		
	A control error occurred while actuating diesel engine.	Diesel engine is damaged.	Shut off diesel engine. Contact Liebherr customer service.
	Control unit of diesel engine is defective.	Diesel engine is damaged.	Shut off diesel engine. Contact Liebherr customer service.
	Engine speed sensor is defective.	Diesel engine is damaged.	Shut off diesel engine. Contact Liebherr customer service.
	An error occurred in the injection system of diesel engine.	Diesel engine is damaged.	Shut off diesel engine. Contact Liebherr customer service.
	Prewarning: A control error occurred during actuation of diesel engine, emergency shut-off of diesel engine is recommended.	Diesel engine runs in emergency mode. Diesel engine is damaged.	Shut off diesel engine. Contact Liebherr customer service.
	Control errors occurred during actuation of diesel engine, emergency shut-off of diesel engine is recommended.		
	A synchronisation error occurred while actuating the diesel engine.	Diesel engine is damaged.	Shut off diesel engine. Contact Liebherr customer service.
	Control circuit of hydraulic system is depressurised.	Control of attachment and uppercarriage is not possible.	Shut off diesel engine and restart. If symbol is still displayed: Contact Liebherr customer service.
	A general control error has occurred.	Functionality is restricted. Machine is damaged.	Shut off diesel engine. Contact Liebherr customer service.
	Software parameters missing after software update.	Diesel engine does not start.	Contact Liebherr customer service.
	Combination of machine and attachment – parameters do not match.	Diesel engine output is reduced automatically.	Contact Liebherr customer service.

LHB11645668/01/2015-12-15/en

5 Maintenance

5.1 Inspection and maintenance schedule

Wartung / Inspektion bei Betriebs- stunden	
bei Übergabe	
alle 8-10 h	●
alle 50 h	■
alle 500 h	○
alle 1000 h	□
alle 2000 h	◇
alle 3000 h	⊛
andere Intervalle	

Abbreviations used in this section: h = operating hours

Various symbols divide the maintenance work into two groups.

Maintenance personnel

●	■	○	□	◇	⊛	+
						*
						●250h

Maintenance work by the machine owner or the maintenance personnel under their own responsibility

Symbols: solid circle, solid square, solid star and snow flake

Maintenance intervals: every 10 and 50 operating hours (h) and special intervals

Authorised specialist personnel

○	□	◇	⊛	⊕
				*
				○6000h

Maintenance and inspection work by authorised specialist personnel from Liebherr or a Liebherr dealership

Symbols: empty circle, empty square, empty star and snow flake

Maintenance intervals: on delivery and every 500, 1000, 2000, 3000 operating hours (h) and special intervals

A list of necessary spare parts for maintenance and inspection work can be found under the "SERVICE PACKAGE" in the spare parts list.

5.2.2 Lubricating chart

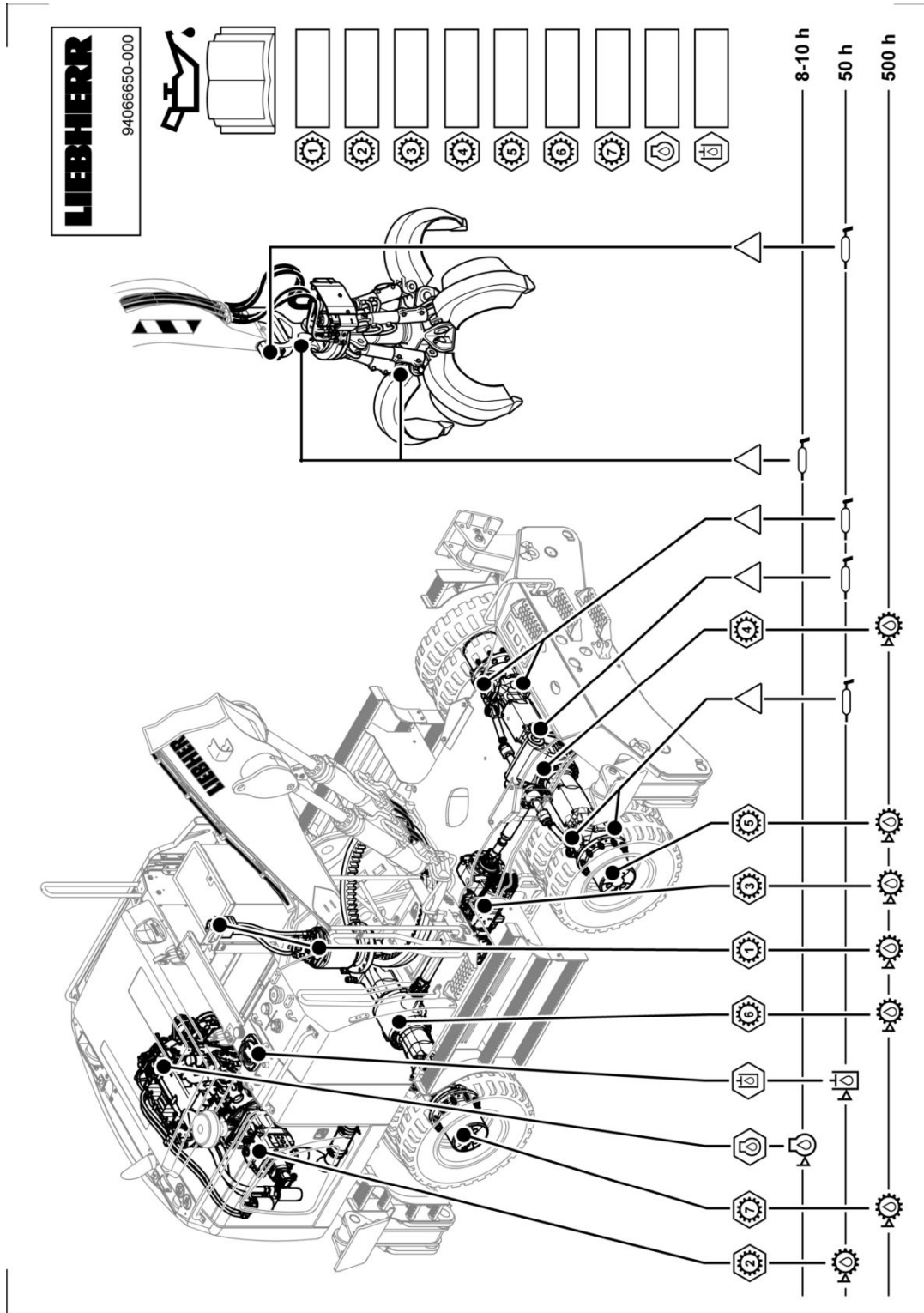

LHB11645668/01/2015-12-15/en

Fig. 663: Lubricating chart

5.4 Access points for maintenance work

5.4.1 Access points on uppercarriage

General overview

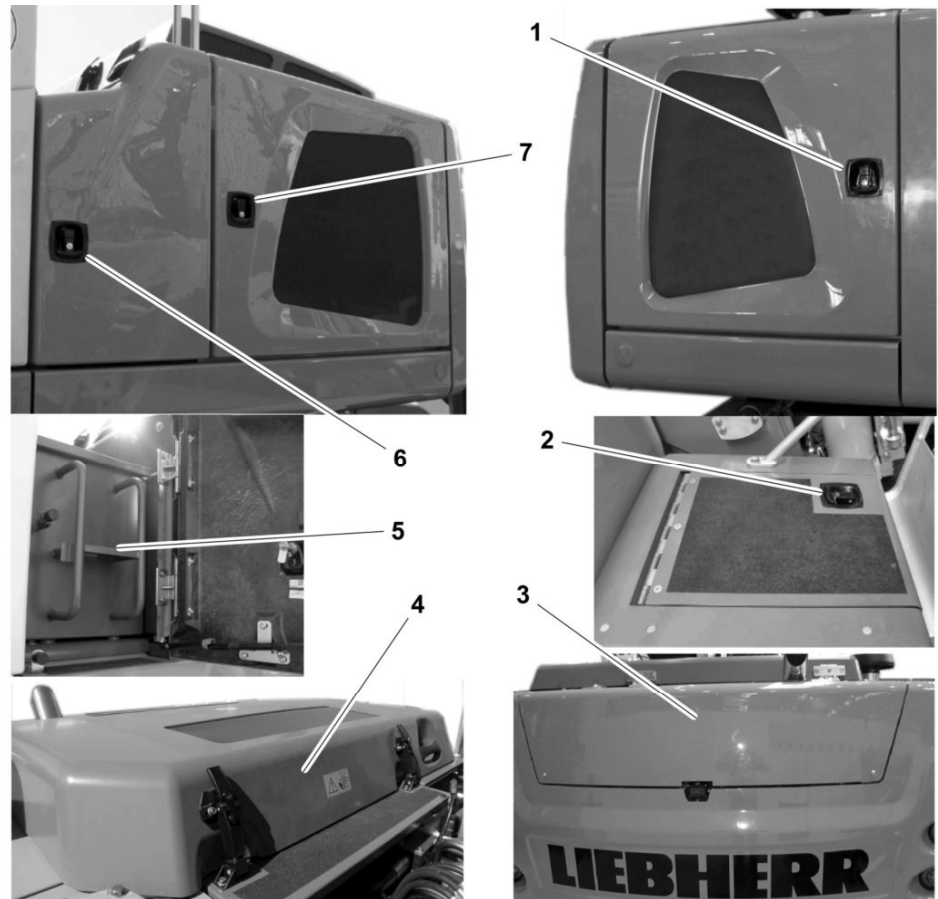

Fig. 673: Access points on uppercarriage

No.	Access point	Access to
1	Right side door	Oil filter, air filter
2	Cab access	Fuel tank
3	Rear hood	Exhaust muffler, diesel particulate filter
4	Engine bonnet	Diesel engine, coolant container, fuel pre-filter, fuel fine filter, hydraulic pumps, servo control unit
5	Tool boxes with cab access	On-board tool kit
6	Middle left side door	Battery main switch, cab access, hydraulic tank, grease container and engine bonnet

5.7.3 Checking components for cracks

- ▶ Carefully check frame components and bearings in operator's cab, uppercarriage and undercarriage for cracks or hairline cracks.

If there are cracks or hairline cracks:

- ▶ Have machine checked and repair work performed by Liebherr customer service.

5.7.4 Lubricating hinges, locks and gas pressure springs of doors, hoods and windows

- ▶ Lubricate hinges regularly with oil or grease.
- ▶ Regularly lubricate locks with resin-free oil or commercially available door lock care product (with graphite or MoS₂ compounds).
- ▶ Lubricate the joints of the gas pressure springs regularly with oil or grease.

5.7.5 Cleaning and treating rubber seals on doors and hoods

Rubber seals are treated with a rubber care product:

- to prevent premature wear
- to prevent freezing at low temperatures

Recommended care products: Silicone, talcum, deer tallow

- ▶ Clean and service rubber seals on doors and panels as required.

5.7.6 Inspecting rescue system

Visual inspection



Note

- ▶ Liebherr recommends documenting inspection of rescue system with inspection table.

- ▶ Make sure rescue system is ready for use: Perform visual inspection every year.
- ▶ Make sure that suitcase is undamaged.
- ▶ Make sure that lead seal on suitcase is undamaged.
- ▶ Make sure that inspection date on inspection seal is not exceeded.

If inspection has negative result:

- ▶ Have rescue system inspected by manufacturer.
- ▶ After return by manufacturer, stow rescue system in intended space in operator's cab.

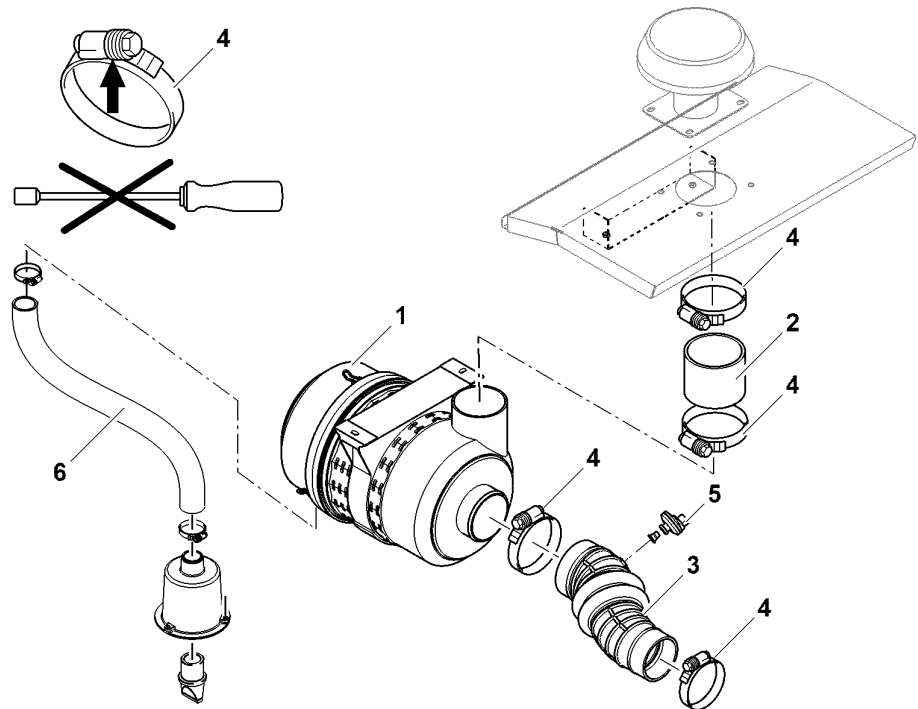

Fig. 684: Filter housing, clean air line and air hose with hose clamps

1	Filter housing	4	Hose clamp with spring plate package
2	Air hose	5	Vacuum switch
3	Clean air line	6	Air hose

NOTICE

Loose or damaged hose connections!
Diesel engine damage.

- ▶ Regularly check hose connections and hose clamps.
- ▶ Replace damaged hose connections.
- ▶ Replace hose clamps on loose or damaged hose connections.
- ▶ Observe prescribed tightening torques.

Check the following air lines:

- Between air filter and turbocharger
- Between turbocharger and intercooling air cooler
- Between intercooling air cooler and diesel engine

The hose clamps 4 with spring plate package compensate any diameter changes.

- ▶ For loose hose connections replace hose clamp 4.
- ▶ Tighten hose clamp, observe prescribed tightening torque specified in table.

Check following components for condition, mounting and tightness:

- Filter housing 1
- All mounting clamps
- All intake lines
- All intake pipes

5.11 Electrical system

5.11.1 General information

Before any intervention in electrical system

- ▶ Put on safety glasses and work gloves.
- ▶ Switch off battery main switch.
- ▶ Disconnect batteries: First disconnect negative terminal (-).
- ▶ Connect batteries: Connect negative terminal (-) last.

General maintenance work

- ▶ Check correct condition of electrical system.
- ▶ Have all defects repaired immediately.

If fuse or bulb is damaged:

- ▶ Remove cause.
- ▶ Replace damaged fuse or bulb immediately.

- | | |
|--|--|
| <p>2 Automatic air conditioning temperature display</p> <p>3 6 temperature levels temperature display (emergency mode of automatic air conditioning)</p> <p>4 12 temperature levels temperature display (air conditioning unit)</p> <p>5 Raise temperature button</p>
<p>6 Operating status of air outlets</p> <p>7 Head area air outlets button</p> <p>8 Chest area air outlets button</p> | <p>10 Raise blower power button</p> <p>11 Heating and air conditioning menu</p> <p>12 Lower blower power button</p> <p>13 Automatic mode button (not in emergency mode of automatic air conditioning and air conditioning unit)</p> <p>14 ECON button (not in emergency mode of air conditioning unit)</p> <p>15 Recirculated air button</p> <p>16 Defrosting and defogging button</p> |
|--|--|

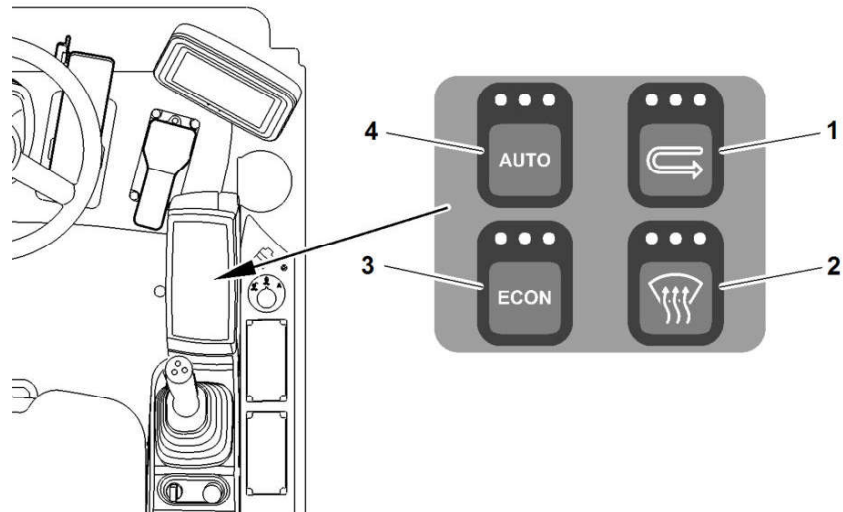

Fig. 703: Operation using keys

- | | |
|--------------------------------|----------------------|
| 1 Recirculated air key | 3 ECON key |
| 2 Defrosting and defogging key | 4 Automatic mode key |

- ▶ Start diesel engine.
- ▶ Bring diesel engine to operating temperature.
- ▶ Open air outlets in operator's cab.
- ▶ Switch on automatic mode.



- ▶ Switch on defrosting and defogging.



- ▶ Switch on recirculated air.

CLICK HERE TO **DOWNLOAD** THE COMPLETE MANUAL

- Thank you very much for reading the preview of the manual.
- You can download the complete manual from: www.heydownloads.com by clicking the link below



- Please note: If there is no response to CLICKING the link, please download this PDF first and then click on it.

CLICK HERE TO **DOWNLOAD** THE COMPLETE MANUAL