

en

Operator's manual

Material handling machine

Document ID

	ORIGINAL OPERATOR'S MANUAL
Order number:	12200354
Issued:	2020-09-03
Version:	01
Author:	LHB / Technical Documentation Department

Product ID

Manufacturer:	Liebherr-Hydraulikbagger GmbH
Type:	LH 110 C Litronic High Rise
Type no.:	1228
From Serial no.:	79878

Contact

Liebherr-Hydraulikbagger GmbH
Liebherrstraße 12
D – 88457 Kirchdorf/Iller

CLICK HERE TO **DOWNLOAD** THE COMPLETE MANUAL

- Thank you very much for reading the preview of the manual.
- You can download the complete manual from: www.heydownloads.com by clicking the link below



- Please note: If there is no response to CLICKING the link, please download this PDF first and then click on it.

CLICK HERE TO **DOWNLOAD** THE COMPLETE MANUAL

3	Control and operation	59
3.1	Control and operating elements	59
3.1.1	Overview of operator's platform	59
3.1.2	Control unit A	61
3.1.3	Control unit B	62
3.1.4	Further control units	62
3.1.5	Symbols on control description sticker	63
3.2	Display	71
3.2.1	Display	71
3.2.2	Status symbols	72
3.2.3	Start page menu	85
3.2.4	Camera menu	86
3.2.5	Air conditioning	88
3.2.6	Operating status menu	90
3.2.7	Diesel particulate filter submenu (option)	91
3.2.8	Sensor-controlled low idle automatic and automatic engine stop submenu (option)	91
3.2.9	System settings menu	92
3.2.10	Operating hour meter and odometer submenu	93
3.2.11	Windscreen wiper interval submenu	94
3.2.12	Radio remote control submenu	94
3.2.13	Display settings submenu	95
3.2.14	Display brightness and display volume submenu	95
3.2.15	Camera image contrast submenu	96
3.2.16	Camera return time submenu	96
3.2.17	Regional settings and system parameters submenu	97
3.2.18	Unit selection submenu	98
3.2.19	System diagnosis submenu	98
3.2.20	Time zone submenu	99
3.2.21	Time format and date format submenu	99
3.2.22	Language selection submenu	100
3.2.23	Electrical outputs submenu	100
3.2.24	Electrical inputs submenu	101
3.2.25	Function settings menu	102
3.2.26	Central lubrication system submenu (option)	103

1.2 Technical data

1.2.1 Vibration emission

Designation	Unit	Value
Hand/arm vibrations	m/s ²	≤ 2.5
Whole-body vibrations	m/s ²	≤ 0.5

Tab. 1: Vibration emission

Operator's seat

- The operator's seat built into this machine by the manufacturer conforms to ISO 7096:2000, EM 6.

Hand/arm vibrations

- If the machine is operated as intended, the weighted (frequency-weighted) effective value of the hand/arm vibrations in accordance with ISO 5349- 1:2001 is less than 2.5 m/s².

Whole-body vibrations

- This value conforms to the details of technical report ISO/TR 25398:2006.
- The measuring inaccuracy is defined in standard EN 12096:1997.
- As the specified values are individual effective values for specific typical application areas, only a limited assessment of the load imposed on the operator by whole-body vibrations is possible.

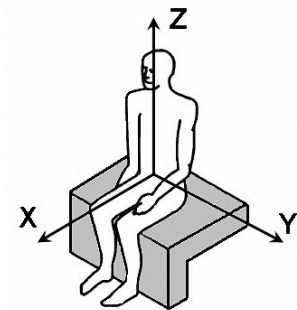

1.2.2 CO₂ emissions of diesel engine

NOTICE

Incorrect operation!
High emission values.

- ▶ Operate and service diesel engine and exhaust treatment system according to operator's manual.



Operator's Cab

Cab	safety cab structure with fixed built-in front and roof window made from impact-resistant laminated safety glass, work headlights integrated in the ceiling, a door with a sliding window (can be opened on both sides), large stowing and depositing possibilities, shock-absorbing suspension, sounddamping insulating, tinted laminated safety glass, separate shades for the sunroof window and windscreen
High Rise/Gantry	deviating from standard: safety cab structure with fixed built-in front and roof window made from impact-resistant laminated safety glass
Operator's seat Comfort	air cushioned operator's seat with 3D-adjustable armrests, headrest, lap belt, seat heater, adjustable seat cushion inclination and length, lockable horizontal suspension, automatic weight adjustment, adjustable suspension stiffness, pneumatic lumbar vertebrae support and passive seat climatization with active coal
Operator's seat Premium (Option)	in addition to operator's seat comfort: active electronic weight adjustment (automatic re-adjustment), pneumatic low frequency suspension and active seat climatization with active coal and ventilator
Control system	joysticks with control consoles and swivel seat, folding left control console
Operation and displays	large high-resolution operating unit, self-explanatory, colour display with touchscreen, video-compatible, numerous setting, control and monitoring options, e.g. air conditioning control, fuel consumption respectively energy consumption, machine and attachment parameters
Air-conditioning	
Diesel engine	automatic air-conditioning, recirculated air function, fast de-icing and demisting at the press of a button, air vents can be operated via a menu; recirculated air and fresh air filters can be easily replaced and are accessible from the outside; heating-cooling unit, designed for extreme outside temperatures, sensors for solar radiation, inside and outside temperatures
Electric motor	in addition to diesel engine: stationary air conditioning function with external climate condenser – controlled by a weekly timer
Refrigerant	R134a
Global warming potential	1,430
Quantity at 25 °C*	1,500 – 2.000 g
CO ₂ equivalent*	2.145 – 2.86 t
Vibration emission**	
Hand/arm vibrations	< 2.5 m/s ²
Whole-body vibrations	< 0.5 m/s ²
Measuring inaccuracy	according with standard EN 12096:1997

* depending on configuration

** for risk assessment according to 2002/44/EC see ISO/TR 25398:2006



Undercarriage

Mobile	
Versions	Standard, High Rise
Drive	one driven axle with transmission with Liebherr axial piston motor and functional brake valve on both sides
Travel speed	
Joystick steering	0 – 5.0 km/h stepless (creeper speed) 0 – 8.0 km/h stepless
Driving operation	automotive driving using accelerator pedal, cruise control function: storage of variable accelerator pedal positions
Axles	90 t drive axles; manual or automatic hydraulically controlled front axle oscillation lock
Service brake	two circuit travel brake system with accumulator; wet and backlash-free disc brake
Holding brake	wet multi-disc (spring applied, pressure released)
Stabilization	4 point outriggers
Crawler	
Versions	SW, High Rise, Gantry
Drive	Liebherr compact planetary reduction gear with Liebherr axial piston motor per side of undercarriage
Travel speed	0 – 2.6 km/h stepless (creeper speed) 0 – 4.0 km/h stepless
Brake	functional brake valves on both sides
Holding brake	wet multi-disc (spring applied, pressure released)
Track pads	flat
Tracks	sealed and greased



Equipment

Type	high-strength steel plates at highly stressed points for the toughest requirements. Complex and stable mountings of equipment and cylinders
Hydraulic cylinders	Liebherr cylinders with special sealing and guide system and, depending on cylinder type, shock absorption
Energy recovering cylinder	Liebherr gas cylinder with special sealing and control system
Bearings	sealed, low maintenance



Complete Machine

Lubrication	Liebherr central lubrication system for upper-carriage and equipment, automatically
Mobile (Option)	Liebherr central lubrication system for undercarriage, automatically
Steps system	safe and durable access system with anti-slip steps; main components hot-galvanised
Noise emission	
ISO 6396	L _{pA} (inside cab) = 70 dB(A) (Stage V)
2000/14/EC	L _{WA} (surround noise) = 107 dB(A) (Stage V)
ISO 6396	L _{pA} (inside cab) = 70 dB(A) (Stage IIIA compliant)
2000/14/EC	L _{WA} (surround noise) = 107 dB(A) (Stage IIIA compliant)
ISO 6396	L _{pA} (inside cab) = not specified (Electric)
2000/14/EC	L _{WA} (surround noise) = not specified (Electric)

LH 110 C – Equipment GA23

Industry – Kinematic 2A

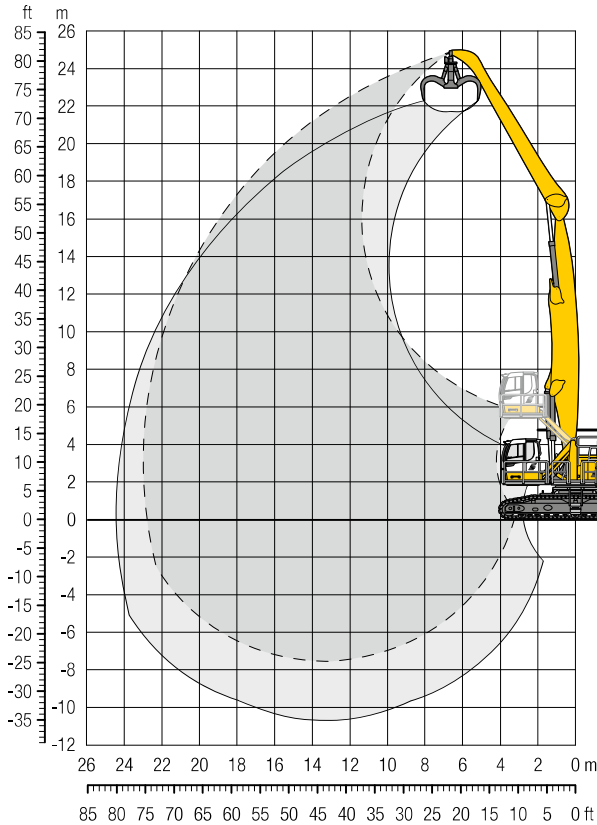

Operating Weight and Ground Pressure

The operating weight includes the basic machine with hydr. cab elevation, straight boom 13.00 m, angled stick 10.50 m and multi-line grab GMM 120-5/2.00 m³ semi-closed tines.

Weight	104,500 kg
Pad width	750 mm
Ground pressure	on request

Dimensions

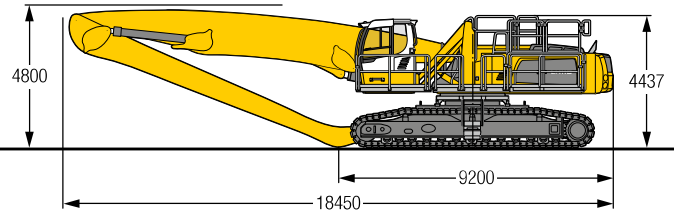

m	Undercarriage	6.0 m		7.5 m		9.0 m		10.5 m		12.0 m		13.5 m		15.0 m		16.5 m		18.0 m		19.5 m		21.0 m		22.5 m		24.0 m		m			
		SW	SW	SW	SW	SW	SW	SW	SW	SW	SW	SW	SW	SW	SW	SW	SW	SW	SW	SW	SW	SW	SW	SW	SW	SW	SW	SW	SW		
24.0	SW					12.8*	12.8*																					12.6*	12.6*	9.1	
22.5	SW							13.3*	13.3*	10.7*	10.7*																	10.6*	10.6*	12.1	
21.0	SW							14.9*	14.9*	13.3*	13.3*	11.1*	11.1*															9.5*	9.5*	14.2	
19.5	SW									13.5*	13.5*	12.2*	12.2*	11.0*	11.0*														8.8*	8.8*	16.0
18.0	SW									13.3*	13.3*	12.1*	12.1*	11.1*	11.1*	10.3*	10.3*												8.4*	8.4*	17.4
16.5	SW									13.2*	13.2*	12.0*	12.0*	11.0*	11.0*	10.2*	10.2*	9.5*	9.5*										8.0*	8.0*	18.6
15.0	SW									13.2*	13.2*	12.0*	12.0*	11.0*	11.0*	10.1*	10.1*	9.5*	9.5*	8.2*	8.2*								7.8*	7.8*	19.6
13.5	SW									13.3*	13.3*	12.0*	12.0*	11.0*	11.0*	10.1*	10.1*	9.4*	9.4*	8.8*	8.8*								7.6*	7.6*	20.5
12.0	SW									13.4*	13.4*	12.1*	12.1*	11.1*	11.1*	10.2*	10.2*	9.4*	9.4*	8.8*	8.8*	8.1*	8.1*						7.5*	7.5*	21.2
10.5	SW							15.3*	15.3*	13.6*	13.6*	12.3*	12.3*	11.2*	11.2*	10.3*	10.3*	9.5*	9.5*	8.8*	8.8*	8.2*	8.2*						7.4*	7.4*	21.8
9.0	SW					18.0*	18.0*	15.7*	15.7*	13.9*	13.9*	12.4*	12.4*	11.3*	11.3*	10.3*	10.3*	9.5*	9.5*	8.9*	8.9*	8.2*	8.2*						7.4*	7.4*	22.2
7.5	SW					21.1*	21.1*	18.6*	18.6*	16.1*	16.1*	14.2*	14.2*	12.7*	12.7*	11.5*	11.5*	10.5*	10.5*	9.6*	9.6*	8.9*	8.9*	8.2*	8.2*	7.6*	7.6*		7.5*	7.5*	22.6
6.0	SW	27.2*	27.2*	23.2*	23.2*	19.3*	19.3*	16.6*	16.6*	14.5*	14.5*	12.9*	12.9*	11.6*	11.6*	10.6*	10.6*	9.7*	9.7*	8.9*	8.9*	8.2*	8.2*	7.5*	7.5*		7.4*	7.4*	22.8		
4.5	SW	31.0*	31.0*	24.3*	24.3*	20.0*	20.0*	17.1*	17.1*	14.9*	14.9*	13.2*	13.2*	11.8*	11.8*	10.7*	10.7*	9.8*	9.8*	9.0*	9.0*	8.2*	8.2*	7.5*	7.5*		7.2*	7.2*	23.0		
3.0	SW	14.9*	14.9*	25.3*	25.3*	20.7*	20.7*	17.5*	17.5*	15.2*	15.2*	13.4*	13.4*	12.0*	12.0*	10.8*	10.8*	9.8*	9.8*	9.0*	9.0*	8.2*	8.2*	7.3*	7.3*		7.0*	7.0*	23.0		
1.5	SW	7.7*	7.7*	20.5*	20.5*	21.2*	21.2*	17.9*	17.9*	15.4*	15.4*	13.6*	13.6*	12.1*	12.1*	10.9*	10.9*	9.8*	9.8*	8.9*	8.9*	8.1*	8.1*	7.1*	7.1*		6.7*	6.7*	22.9		
0	SW	6.5*	6.5*	13.6*	13.6*	21.5*	21.5*	18.1*	18.1*	15.6*	15.6*	13.7*	13.7*	12.1*	12.1*	10.9*	10.9*	9.8*	9.8*	8.8*	8.8*	7.9*	7.9*	6.7*	6.7*		6.4*	6.4*	22.8		
-1.5	SW	6.7*	6.7*	11.9*	11.9*	21.4*	21.4*	18.1*	18.1*	15.6*	15.6*	13.6*	13.6*	12.1*	12.1*	10.8*	10.8*	9.6*	9.6*	8.6*	8.6*	7.5*	7.5*	6.1*	6.1*		6.1*	6.1*	22.5		
-3.0	SW	7.4*	7.4*	11.6*	11.6*	19.3*	19.3*	17.7*	17.7*	15.3*	15.3*	13.4*	13.4*	11.8*	11.8*	10.5*	10.5*	9.3*	9.3*	8.2*	8.2*	7.0*	7.0*				5.9*	5.9*	22.0		
-4.5	SW	8.4*	8.4*	12.0*	12.0*	18.4*	18.4*	16.9*	16.9*	14.7*	14.7*	12.9*	12.9*	11.3*	11.3*	10.0*	10.0*	8.8*	8.8*	7.5*	7.5*						6.4*	6.4*	20.7		
-6.0	SW					17.8*	17.8*	15.6*	15.6*	13.6*	13.6*	12.0*	12.0*	10.5*	10.5*	9.2*	9.2*	7.9*	7.9*								7.2*	7.2*	18.8		
-7.5	SW									10.6*	10.6*																	10.1*	10.1*	14.0	

Height Can be slewed through 360° In longitudinal position of undercarriage Max. reach * Limited by hydr. capacity

The lift capacities on the stick end without attachment are stated in metric tons (t) and can be slewed through 360° on a firm, level supporting surface. Capacities are valid for 750 mm wide flat pads. Indicated loads based on the ISO 10567 standard and do not exceed 75% of tipping or 87% of hydraulic capacity. The lift capacity values indicated are attained at the corresponding operating temperature. This operating temperature is ensured by continuous movement of the boom. Weights of fitted attachments (grabs, load hooks, etc.) and load accommodation attachment are to be deducted from the lift capacity values. The lift capacity of the unit is limited by its stability, the lifting capability of the hydraulic elements, or the maximum permissible lifting capacity of the load hook.

In accordance with the harmonised European Standard EN 474-5, hydraulic excavators used for lifting operations must be equipped with pipe fracture safety valves, an overload warning device, a load hook and a lift capacity chart.

LH 110 C HR - Dimensions

Industry

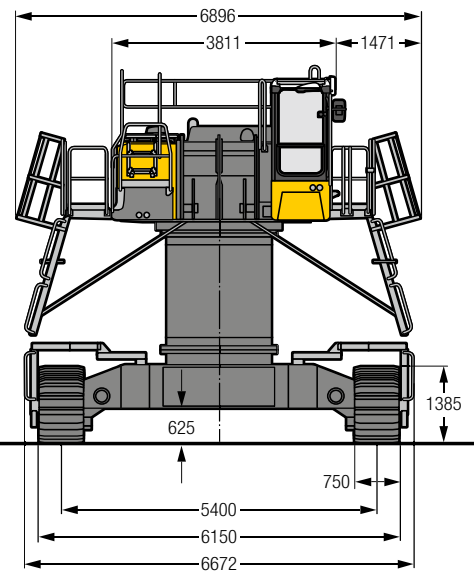
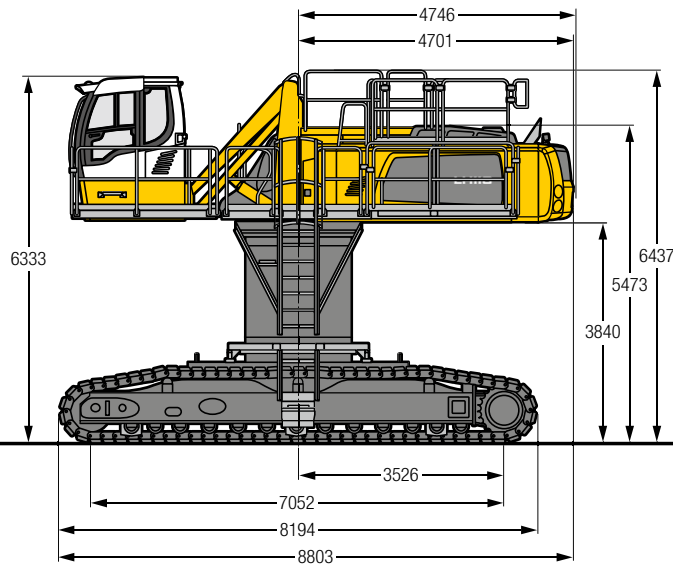

LH 110 C HR - Choice of Cab Elevation

Cab Elevation LHC (Hydraulic Elevation)

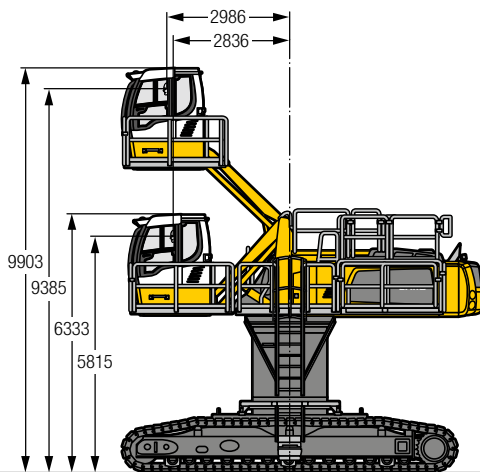

Increase type

LHC 360-50

The hydraulically adjustable cab allows the driver, that he can choose his field of view freely and at any time within the stroke.

Cab Elevation LHC-D (Hydraulic Elevation)

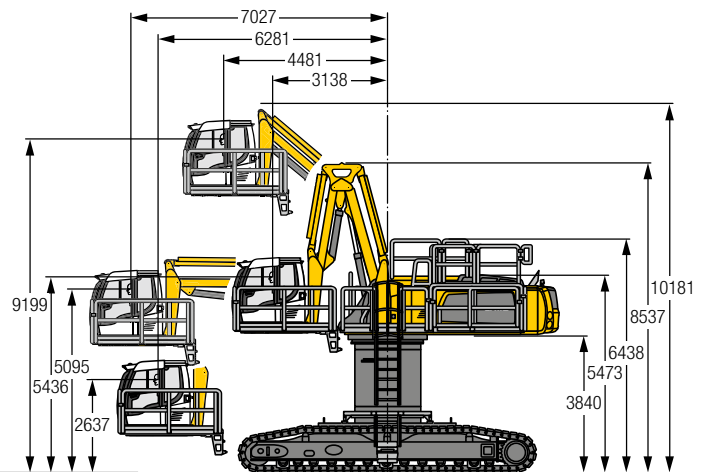

Increase type

LHC-D 730

The hydraulically adjustable cab allows the driver, that he can choose his field of view freely and at any time within the stroke.

2 Safety warnings

2.1 Information on these instructions

2.1.1 Representation of warning messages

Warning symbol

	The warning symbol warns of potential dangers. Obey all measures marked with this symbol to avoid injury or death.
---	--



Tab. 4: Warning symbol

Grading of warning messages

The grading of warning messages is defined by following signal words:

- DANGER**
- WARNING**
- CAUTION**
- NOTICE**

Definition of warning levels

	DANGER	Indicates an immediately hazardous situation which, if not avoided, will result in death or serious injury.
	WARNING	Indicates a hazardous situation which, if not avoided, could result in death or serious injury.
	CAUTION	Indicates a hazardous situation which, if not avoided, could result in minor or moderate injury.
	NOTICE	Indicates a hazardous situation which, if not avoided, could result in property damage.

Tab. 5: Warning levels

2.1.2 Graphic symbols in these instructions

Symbol	Meaning
	Note Identifies useful information and tips.

LHB/1220035/01/2020-09-03/en

- The spotter has the necessary education (theoretical and practical) for the following:
 - Spotting
 - Applying all necessary signal signs
- Is not under any physical or mental impairment that limits one of the prescribed requirements.
- Is not under the influence of alcohol.
- Is not under the influence of drugs.

2.4 Signs on the machine

2.4.1 Warning signs



Note

- ▶ Make sure that all safety signs are in place on the machine and legible.
- ▶ Adhere to warning signs.

Sign	Description
	Safety belt Before putting machine into service, put on safety belt.
	Safety glasses Put on safety glasses before starting work.
	Protective gloves Put on protective gloves before starting work.

LHB/1220035/01/2020-09-03/en

Injuries

Objects in the operator's cab

- Remove objects that are not necessary for the work from the operator's cab.
- Stow and fasten objects that are necessary for the work before starting.
- Make sure that objects carried do not protrude into the operator's workspace.

2.5.3 Height-adjustable operator's cab

Danger to life

Persons in the danger zone

- Make sure there are no persons in the danger zone under the operator's cab.
- Keep your distance from moving parts when the operator's cab is moving down.

Machine tipping

- On slopes, travel with lowered operator's cab.

Injuries

Falling from operator's cab

- Close cab door before raising and adjusting operator's cab.
- If operator's cab is raised: Make sure that cab door is closed.

Damage to operator's cab and machine

Collision with obstacles

- Make sure there are no obstacles in the range of movement of operator's cab.
- Exclusively adjust operator's cab when machine is at a standstill.
- Move operator's cab to upper park position before starting travel.
- Move slowly to end positions (upper or lower park position) using automatic mode.

2.5.4 Roll over protective structure (ROPS)

Danger to life

Damaged falling object protective structures

- Do not put machine into service with damaged falling object protective structures.
- Do not put machine into service with deformed falling object protective structures.
- Do not use falling object protective structures with structural changes.
- Do not use repaired falling object protective structures.
- Do not perform welding on falling object protective structures.
- Do not cut or saw falling object protective structures.
- Do not drill falling object protective structures.

2.8 Safe work

2.8.1 Machine with turret

Danger to life

Unsuitable ground

- Make sure that machine does not sink.
- Check load capacity of ground.
- Check support surface of support.

Incorrect use

- Before operation, align machine to be horizontal.
- Make sure that uppercarriage is aligned parallel to undercarriage.
- Make sure that centre of gravity of the uppercarriage is over centre of undercarriage.
- If the uppercarriage is to be moved from travel position: Support machine.
- Keep raised load close to machine and move close to the ground.
- Avoid sudden braking or acceleration of working attachment.

Incorrect travel

- Drive slowly and carefully.
- Do not drive with raised load.
- Make sure that ground to be driven over is firm and level.
- Retract support legs after aligning uppercarriage.
- Adapt driving behaviour to higher centre of gravity of machine.
- Adapt speed to driving conditions.
- Drive slowly and carefully through narrow passages.
- Avoid sudden speed changes.

2.8.2 Machines with height adjustable cab

Danger to life

Persons in the danger zone

- Make sure there are no persons in the danger zone under the operator's cab.
- If operator's cab is being lowered: Keep distance from moving parts.



Machine tipping

- On slopes, exclusively travel with lowered operator's cab.

Injuries











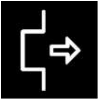









Falling out of operator's cab

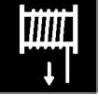













- Make sure that the cab door is closed during adjustment of operator's cab.
- Make sure that cab door is closed when in raised state.

Symbol	Description	Symbol	Description
	Dust extraction		Air compressor

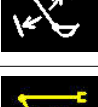

Tab. 12: Optional equipment

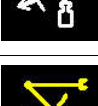
Working tools

Symbol	Description	Symbol	Description
	Quick coupler		Turning tiltrotator left
	Turning grapple		Tilting tiltrotator left
	Turning grapple left		Turning tiltrotator right
	Turning grapple right		Tilting tiltrotator right
	Opening grapple		Opening grapple of tiltrotator
	Closing grapple		Closing grapple of tiltrotator
	Tilting in bottom dump shovel		Uncoiling rope
	Tilting out bottom dump shovel		Coiling up rope
	Lifting bottom dump shovel		Pulling out pipe
	Lowering bottom dump shovel		Pushing pipe in
	Tilting bucket out		Activating pipe grapple





Symbol	Meaning
	Working tool; neutral position required
	Rotary stick; neutral position required
	Grapple active
	Turn grapple; neutral position required
	Open grapple and close grapple; neutral position required
	Main movements of working attachment and slewing gear blocked
	Main movements of working attachment and slewing gear; neutral position required
	Hoist cylinder protection switched off
	Stick cylinder protection switched off
	Boom line break safety open
	Stick cylinder shut-off active
	Stick cylinder shut-off bypassed
	Stick cylinder shut-off for heavy working tool active
	Stick cylinder shut-off for heavy working tool bypassed

LHB12200354/01/2020-09-03/en

Symbol	Meaning
	Pressure relief active
	Bleeding of cooling circuit active
	Heating circuit active

Tab. 31: Status symbols of SCR system

Rail guide system

Symbol	Meaning
	Rail guide system: Additional tyres blocked
	Automatic mode not active
	Neutral position required
	Rail guide system automatically blocked
	Sanding equipment active

Tab. 32: Status symbols of rail guide system

3.2.3 Start page menu

Menu call: 

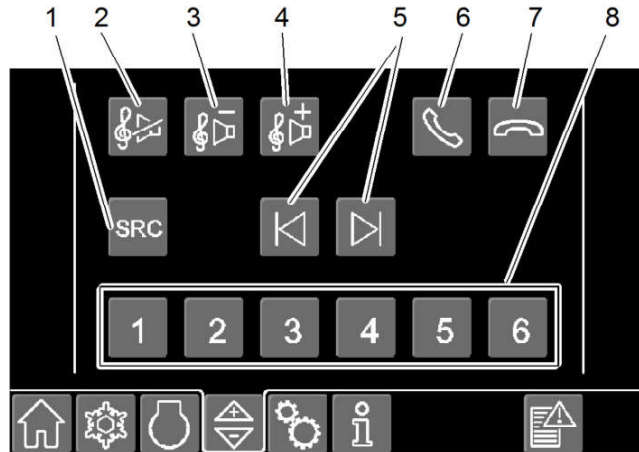





Fig. 395: Radio remote control submenu

- | | | | |
|---|-------------------------------|---|---|
| 1 | Selecting audio source button | 5 | Changing radio station or track buttons |
| 2 | Mute button | 6 | Answering phone call button |
| 3 | Volume down button | 7 | Ending phone call button |
| 4 | Volume up button | 8 | Selecting stored radio station buttons |

3.2.13 Display settings submenu

Menu call:  > 

Menu button	Designation
	Return time (For more information see: 3.2.16 Camera return time submenu , page 96)
	Camera image contrast, side area camera (For more information see: 3.2.15 Camera image contrast submenu , page 96)
	Camera image contrast, rear area camera (For more information see: 3.2.15 Camera image contrast submenu , page 96)
	Display brightness and display volume (For more information see: 3.2.14 Display brightness and display volume submenu , page 95)

Tab. 35: Menu buttons

3.2.14 Display brightness and display volume submenu

Menu call:  >  > 

The display of this submenu varies depending on machine configuration:

LHB/12200354/01/2020-09-03/en

2	Operating hour meter at last maintenance	6	Transmission and axle maintenance ⁶⁾	10	Confirmation of maintenance due message button
3	Maintenance of diesel engine	7	Maintenance due status symbol		
4	Total operating hours	8	Teleservice button		

Maintenance

If *maintenance due* status symbol **7** appears:

- ▶ Contact Liebherr customer service and have maintenance performed.
- ▶ Confirm display: Press *confirmation of maintenance due message* button **10**.
 - ▷ *Maintenance due* status symbol **7** disappears.

Teleservice

Via Teleservice Liebherr customer service reads and modifies parameters of machine control online if necessary.

Activating write access



DANGER

Unexpected machine movement!
Danger to life.

- ▶ Make sure there are no persons in working area of machine.



Note

Malfunctions in machine control!

- ▶ Do not operate machine during write access by Liebherr customer service.



- ▶ Press *teleservice* button **8** when prompted by Liebherr customer service.
 - ▷ *Teleservice* button **8** is displayed in green.
 - ▷ *Teleservice activated* status symbol **9** appears.
 - ▷ Online connection is enabled.
 - ▷ Liebherr customer service has write access to machine control parameters.

Deactivating write access

Liebherr customer service deactivates write access.

Read access

Read access is always possible for Liebherr customer service. It is not necessary that the operator enables the online connection.

3.2.28 SF submenu

Menu call:  > 

⁶⁾ Applies to machines with wheeled undercarriage

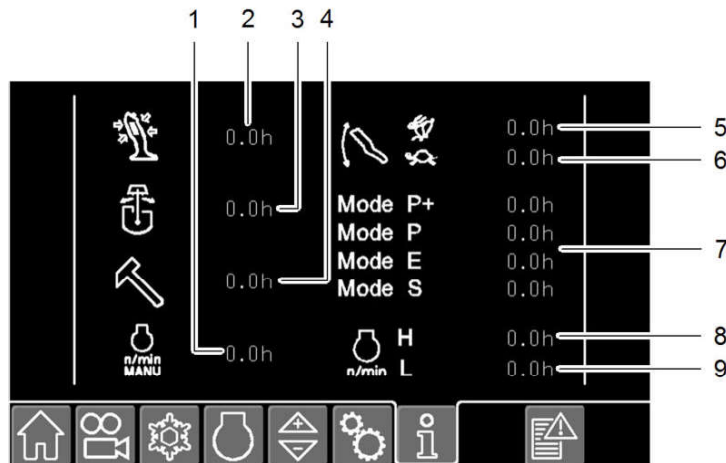

Fig. 465: Operating time submenu

- | | | | |
|---|-------------------------|---|----------------------------|
| 1 | No function assigned | 6 | Travelling in creeper gear |
| 2 | Joysticks | 7 | Modes |
| 3 | Slewing gear | 8 | Maximum engine speed |
| 4 | Working tool | 9 | Minimum engine speed |
| 5 | Travelling in high gear | | |

3.2.40 Fuel consumption submenu

If machine is equipped with an SCR system, the *fuel consumption* menu additionally displays the values for the consumption of diesel exhaust fluid.

Menu call:  > 

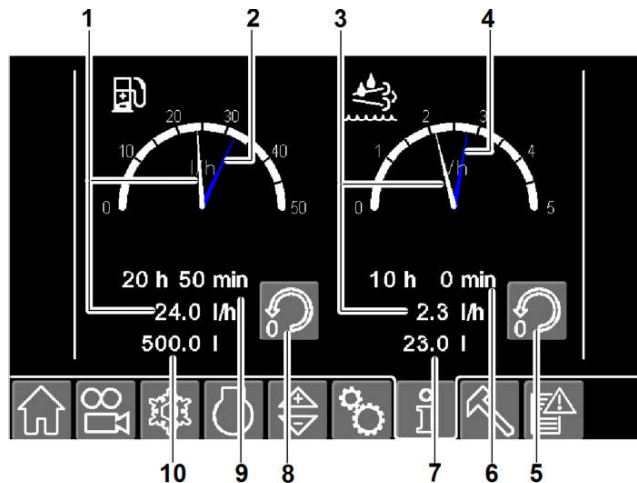

Fig. 466: Fuel consumption submenu

- | | | | |
|---|--|----|-------------------------------|
| 1 | Average fuel consumption | 6 | Measurement period |
| 2 | Current fuel consumption | 7 | Consumed diesel exhaust fluid |
| 3 | Average diesel exhaust fluid consumption | 8 | Resetting counter button |
| 4 | Current diesel exhaust fluid consumption | 9 | Measurement period |
| 5 | Resetting counter button | 10 | Consumed fuel |

- ▶ Guide the saw blade into the hole and make one saw cut each to the left, upwards and right (3.).
- ▶ Push window outwards.
- ▶ Exit through the opening.

3.3.6 Fire extinguisher (option)



DANGER

Incorrect use of fire extinguisher!
Danger to life.

- ▶ Use fire extinguisher exclusively to extinguish blocked escape routes.
- ▶ Do not use fire extinguisher on electrical systems exceeding 1000 V.
- ▶ Adhere to instructions on fire extinguisher.

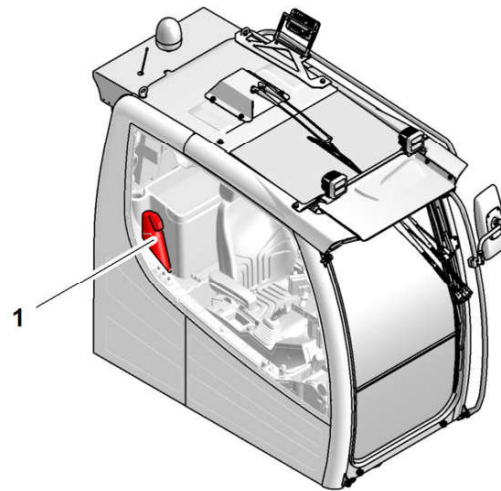

Fig. 486: Fire extinguisher

1 Fire extinguisher

3.3.7 Folding console

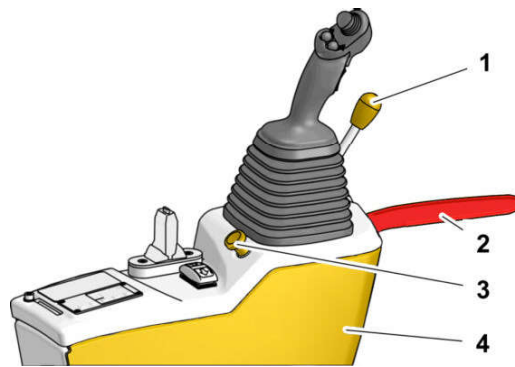

Fig. 487: Folding console

1 Console handle	3 Unlocking button
2 Safety barrier	4 Folding console

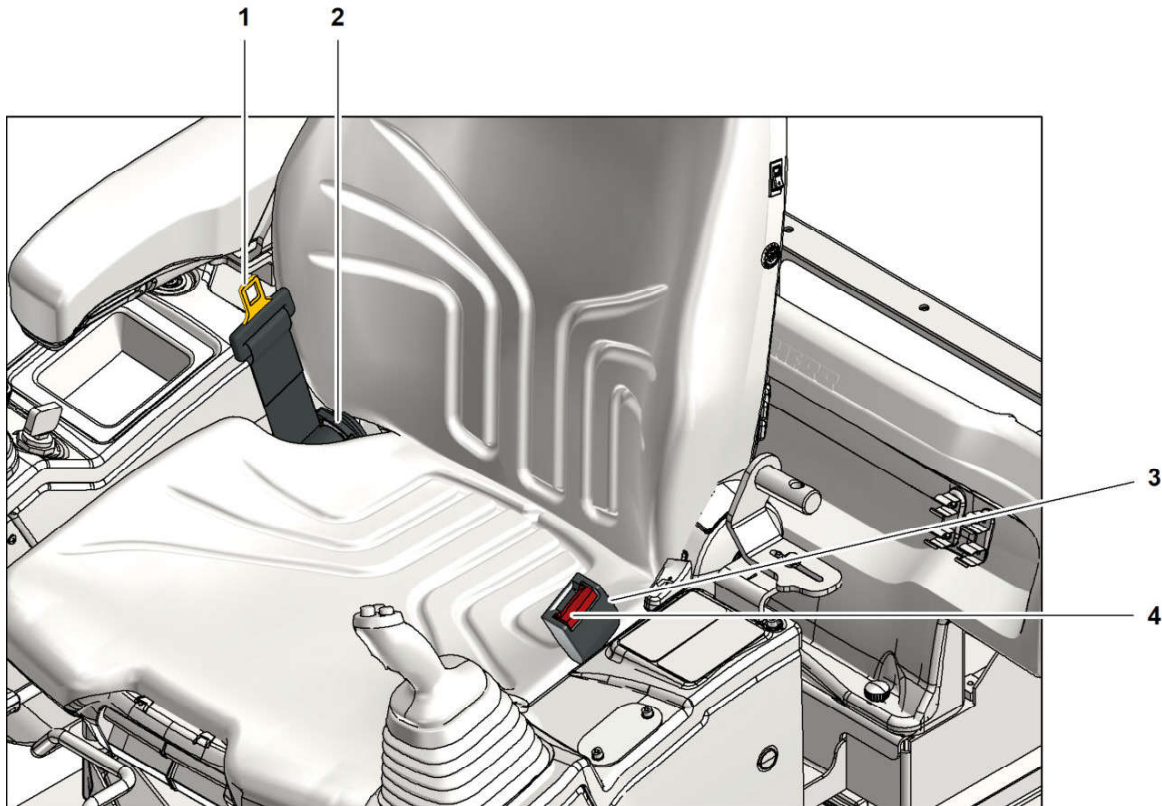

Fig. 507: Safety belt

- | | | | |
|---|-------------------|---|------------------|
| 1 | Belt buckle latch | 3 | Belt buckle |
| 2 | Belt reel | 4 | Unlocking button |

**DANGER**

Defective safety belt!
Danger to life.

- ▶ Check condition and function of safety belt.
- ▶ Immediately replace damaged parts.

Putting on safety belt

- ▶ Unroll safety belt from belt reel 2.
 - ▷ Safety belt can lock in case of sudden unrolling.
- ▶ Insert belt buckle latch 1 in belt buckle 3.

Releasing safety belt

- ▶ Press unlocking button 4.
 - ▷ Safety belt is wound onto belt reel 2.

Upper windscreen

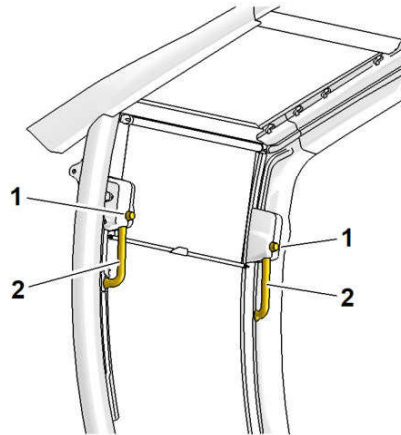

Fig. 543: Upper windscreen

1 Knob

2 Handle

Opening upper windscreen

- ▶ Unlock upper windscreen: Press knobs **1** simultaneously.
- ▶ Push upper windscreen upwards with handles **2** and pull back until it engages in roof of operator's cab.

Closing upper windscreen

- ▶ Unlock upper windscreen: Press knobs **1** simultaneously.
- ▶ Pull upper windscreen forwards and downwards with handles **2** until it engages in front in operator's cab.

Complete windscreen

Opening complete windscreen

- ▶ Open lower windscreen.
- ▶ Open upper windscreen.

Closing complete windscreen

- ▶ Close upper windscreen.
- ▶ Close lower windscreen.

CLICK HERE TO **DOWNLOAD** THE COMPLETE MANUAL

- Thank you very much for reading the preview of the manual.
- You can download the complete manual from: www.heydownloads.com by clicking the link below



- Please note: If there is no response to CLICKING the link, please download this PDF first and then click on it.

CLICK HERE TO **DOWNLOAD** THE COMPLETE MANUAL

3.4.2 Refuelling

The machine is refuelled at the top of fuel tank. The tank lid can be locked.

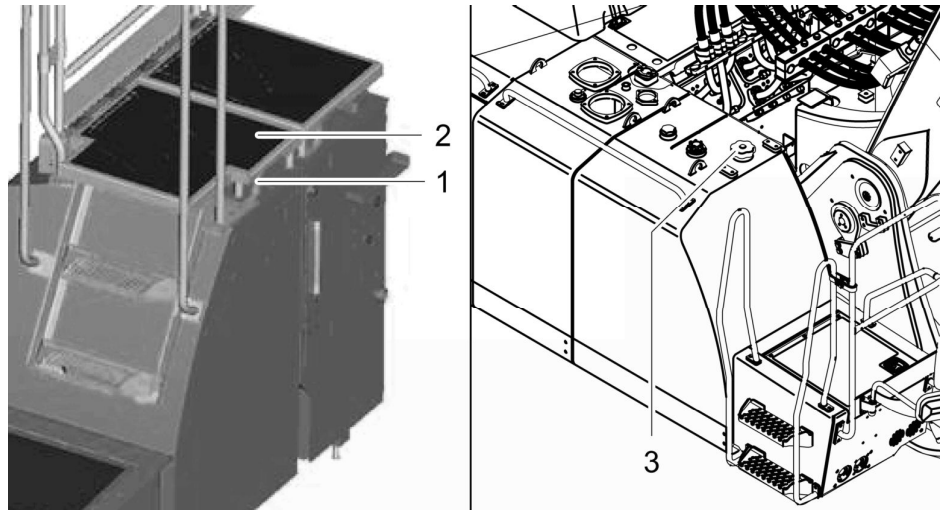

Fig. 582: Fuel tank

- 1 Clamping lock
- 2 Folding step

- 3 Tank lid



DANGER

Explosion of highly flammable fuel!
Danger to life.

- ▶ Avoid naked flames.
- ▶ Do not smoke.



Note

Sulphur content of fuel affects change interval of engine oil and oil filter.

- ▶ Adhere to sulphur content of fuel and change intervals of engine oil. (For more information see: [Difficulty factors, page 280](#))

If sulphur content of fuel is not known:

- ▶ Determine sulphur content with oil analysis set.

- ▶ Shut off diesel engine.
- ▶ Open clamping lock 1.
- ▶ Fold up folding step 2.
- ▶ Open tank lid 3.
- ▶ Fill with clean fuel through strainer until required fuel fill level is reached.
- ▶ Close tank lid 3.
- ▶ Lock tank lid 3.
- ▶ Fold down folding step 2.
- ▶ Close clamping lock 1.

3.4.22 Turning and braking uppercarriage

Turning uppercarriage

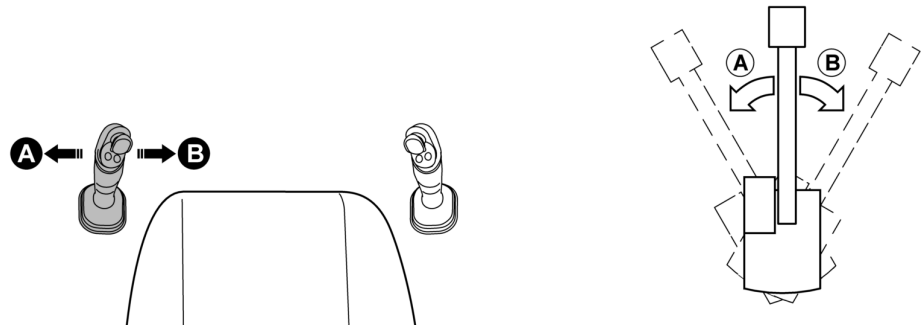

Fig. 625: Turning uppercarriage





Make sure the following preconditions are met:

- Slewing brake is released.
- ▶ Move joystick in direction **A**.
 - ▷ Uppercarriage turns to the left.
- ▶ Move joystick in direction **B**.
 - ▷ Uppercarriage turns to the right.



Braking uppercarriage

- ▶ Release joystick.
 - ▷ Uppercarriage is braked hydraulically.
- ▶ Move joystick in opposite direction.
 - ▷ Uppercarriage is braked hydraulically to maximum extent.

3.4.23 Slewing brake

Key	Status of LEDs	Slewing brake
	LEDs light up 	Applied
	LEDs do not light up 	Released
	Two LEDs flash 	Slewing brake is applied as soon as uppercarriage is stationary.

Tab. 56: Status of slewing brake

Key	Status of LEDs	Function
	○ ○ ○	Grapple priority: Suitable for loads that require a significant closing force from the grapple. Working attachment movements are slower.
		Reduced grapple priority: Suitable for loads that require a low closing force from the grapple. Working attachment movements remain fast and smooth.

Tab. 57: Grapple priority key



Make sure the following preconditions are met:

- Grapple is selected in *Tool Control* menu.
- Grapple* status symbol appears on the display.



- ▶ Press *grapple priority* key.
 - ▷ LEDs in key light up.

3.4.31 AutoLift (Option)

The “ AutoLift ” function raises the working attachment when the grapple closes. This reduces the danger of the grapple damaging the loading surface.

NOTICE

Careless movement of working attachment!
Damage to loading surface.

- ▶ Move working attachment carefully.
-



- ▶ Select AutoLift speed in *SuperFinish* menu.
- ▶ Press *AutoLift* key.
 - ▷ LEDs in key light up.
 - ▷ Working attachment is raised when grapple closes.

3.4.32 Magnet system (option)

Activation of magnet system has following effects:

- Folding console has no effect on engine speed.
- Manually increasing engine speed is possible.
- Lowering engine speed is not possible.



Switching off hoist cylinder shut-off

- ▶ Press *function settings* menu button.
- ▶ *Hoist cylinder shut-off* menu button.
- ▶ Press *hoist cylinder shut-off* button 1.
 - ▷ *Confirmation required* status symbol appears on the display:



- ▶ Press confirmation button within 5 seconds.
 - ▷ *Hoist cylinder shut-off* button lights up white:



Setting hoist cylinder shut-off



DANGER

Swinging working tool!
Danger to life.

- ▶ Set shut-off points with adequate safe distance (swinging working tool, long stopping distance for working attachment).

Teaching in upper shut-off point

If hoist cylinder shut-off is switched on, new shut-off points are exclusively possible within approved movement range.

- ▶ Put machine in working position.

If machine is equipped with 4-point support:

- ▶ Extend support.

If the machine is equipped with 2-point support or a support blade:

- ▶ Extend support and move working attachment over support.

- ▶ Move boom up to required maximum working height.



- ▶ Press *upper shut-off point* button 3.

▷ *Confirmation required* status symbol appears on the display:



- ▶ Press confirmation button within 5 seconds.
 - ▷ Upper shut-off point is saved.



Scale	Status symbol	Meaning
Font colour of current height of working attachment 2 is red. Arrow is at set limit value.		Movement of working attachment has stopped. Exclusively movement into safe area possible.
Font colour of current height of working attachment 2 is red. Arrow is in red area of scale.		Height limitation is bypassed.

Tab. 66: Height limitation function

**DANGER**

Collision between working attachment and obstacles!
Danger to life.

- ▶ Move working attachment slowly.

**DANGER**

Collision between working attachment and obstacles!
Danger to life.

When height limitation stops movement of working attachment:

- ▶ Do not change position of support.
- ▶ Exclusively move laterally adjustable boom into safe area.
- ▶ Make sure that operator is informed of changed limit values.
- ▶ Checking height limitation. (For more information see: [Checking height limitation, page 206](#))

Bypassing height limitation

It is possible to bypass the height limitation temporarily. After 10 seconds, the working attachment can exclusively be moved downward.

**DANGER**

Collision between working attachment and obstacles!
Danger to life.

- ▶ Bypass height limitation exclusively in exceptional cases.
- ▶ Carefully move working attachment.



- ▶ Press *bypassing height limitation* key.
- ▶ Press confirmation button.
 - ▷ *Height limitation bypassed* status symbol appears on the display:



- ▷ Height limitation is bypassed for 10 seconds.
- ▷ Intermittent warning sound sounds.

- If measured working depth undershoots set limit value:
- ▶ Contact Liebherr customer service.

3.5.5 Overload warning system (option)



Note

The overload warning system warns during work before maximum permitted load is exceeded.

Load-increasing movements do not stop.

Activating overload warning system

An activated overload warning system is active after machine is started again.



- ▶ Press *overload warning system* key.
 - ▷ LEDs in key light up.

Deactivating overload warning system

- ▶ Press *overload warning system* key.
- ▶ Press confirmation button.
 - ▷ LEDs in key go out.

Working with overload warning system

The load lift values depend on following factors:

- Reach of working attachment
- Counterweight

The load capacity values are changed by installation and removal of attachment components and working tools:

- For backhoe bucket attachment (including bucket cylinder, change lever and joint plate) the values at the tip of stick apply.
- If a quick coupler is used, the load lift values are reduced by approx. 240 kg.



DANGER

Machine tipping over!
Danger to life.

- ▶ Do not exceed maximum permitted load.
- ▶ Move working attachment slowly.

- ▶ Make sure that overload warning system is functioning correctly.



DANGER

Machine tipping over!
Danger to life.

If warning sound sounds and *overload warning* status symbol appears on the display:

- ▶ Exclusively perform load-reducing movements.

- ▶ Slowly press accelerator pedals.
- ▶ Maintain basic travel position while travelling.

If travel is exclusively possible with camera for rear area monitoring:

- ▶ Slowly move machine over short distances.
- ▶ Make sure that camera image is displayed in real time.

3.6.4 Travelling on inclination

Make sure the following preconditions are met:

- Ground has sufficient grip and load-bearing capacity.
- Basic travel position has been assumed. (For more information see: [Basic travel position, page 224](#))
- Oscillating axle support automatic is switched on. ²⁰⁾
- Support is retracted.
- ▶ Adhere to inclination angle. (For more information see: [3.4.20 Observing the inclination angle, page 173](#))
- ▶ Approach target with lowest inclination.
- ▶ Adhere to maximum speed of 2.0 km/h (approx. half walking speed).
- ▶ Drive around corners with largest possible radius.
- ▶ Maintain basic travel position while travelling.
- ▶ Move machine evenly.
- ▶ Press *accelerator pedal* slowly.

3.6.5 Travelling under obstacles

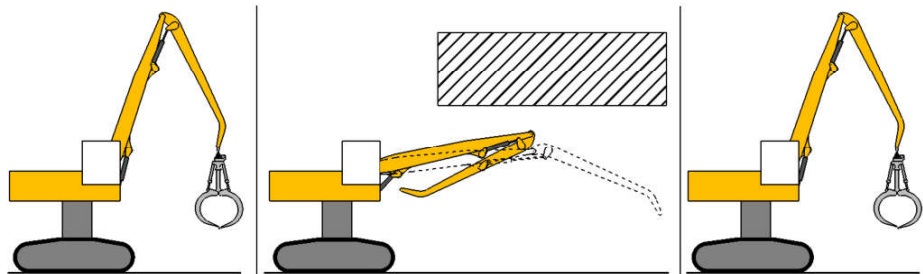

Fig. 789: Travelling under obstacles

- ▶ Drive up to obstacle in basic travelling position.
- ▶ Remove working tool.
- ▶ Lower and retract working attachment.

If it is not possible to travel under the obstacle with lowered and retracted working attachment:

- ▶ Lower and extend working attachment.
- ▶ Travel under obstacle.











²⁰⁾ Applies to machines with wheeled undercarriage.

3.9 Transport and assembly

- ▶ Make sure that machine is assembled exclusively by trained staff.
- ▶ Make sure that machine is dismantled exclusively by trained staff.
- ▶ Make sure that machine is transported exclusively by trained staff.

If the machine is transported or converted:

- ▶ Contact Liebherr customer service.

Symbol	Meaning	Effect, characteristic	Remedy
	Control circuit of hydraulic system is depressurised.	Control of working attachment and uppercarriage is not possible.	Shut off diesel engine and restart. If symbol is still displayed: Contact Liebherr customer service.
	A general control error has occurred.	Functionality is restricted. Machine is damaged.	Shut off diesel engine. Contact Liebherr customer service.
	Software parameters missing after software update.	Diesel engine does not start.	Contact Liebherr customer service.
	Machine and attachment parameters do not match.	Diesel engine output is reduced automatically.	Contact Liebherr customer service.
	Prewarning: Exhaust system is heavily contaminated.		Start manual filter regeneration (see Maintenance).
	Exhaust system is excessively contaminated.	Diesel engine output is reduced automatically.	Contact Liebherr customer service (see Maintenance).
	Prewarning: DPF: Diesel exhaust fluid level is low.		Fill with diesel exhaust fluid.
	DPF: Diesel exhaust fluid level is too low.	Diesel engine output is reduced automatically.	Fill with diesel exhaust fluid.
	SCR: Diesel exhaust fluid level is too low.	Diesel engine output is reduced automatically.	Fill with diesel exhaust fluid.
	Malfunction of oscillating axle.	Machine stability is at risk.	Shut off diesel engine. Contact Liebherr customer service.
	Oil temperature of pump distributor gear is too high.	Pump distributor gear is damaged.	Shut off diesel engine. Reduce load. Clean hydraulic oil cooler. If symbol is still displayed: Contact Liebherr customer service.

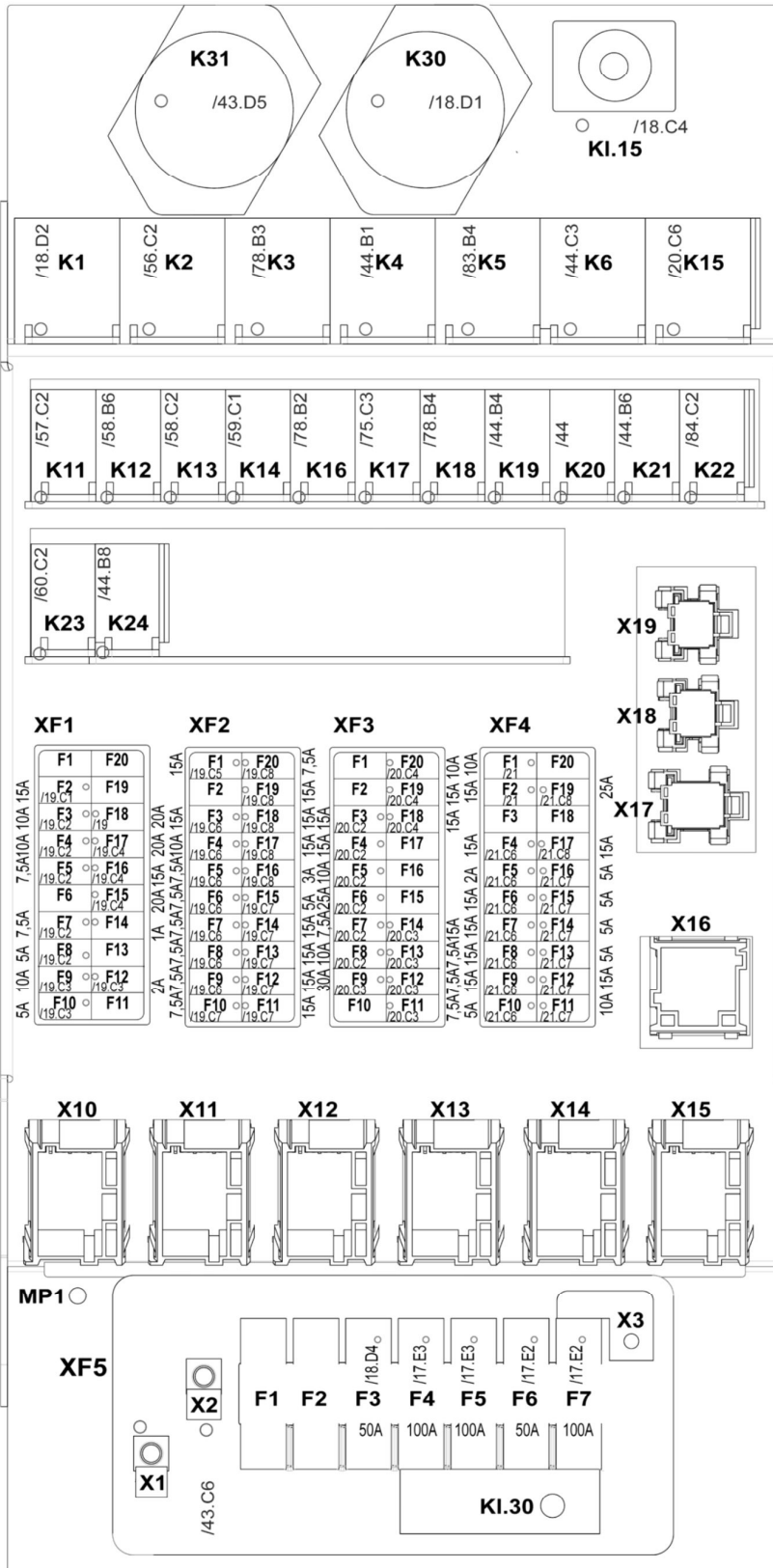

LHB12200354/01/2020-09-03/en

Fig. 871: Electric cabinet A214

Relay	Consumer
K3	Turn indicator

Tab. 80: Additional printed circuit board A166

Make sure the following preconditions are met:

- Battery main switch is set to **OFF**.
- ▶ Fold backrest forwards.
- ▶ Open cover 1.
- ▶ Replace fuse.
- ▶ Close cover 1.

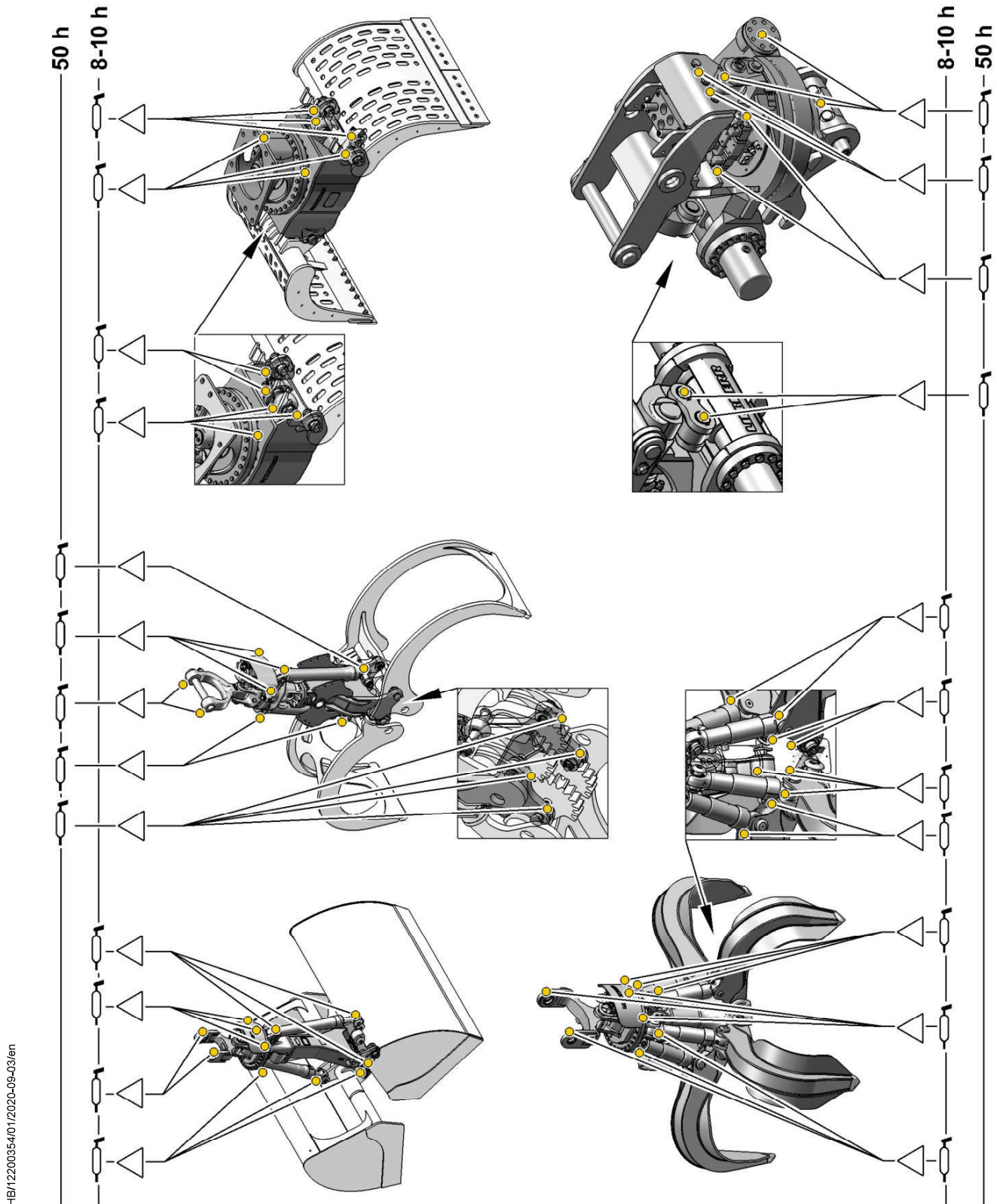

LHB12200354/01/2020-09-03/en

Fig. 877: Lubrication chart for working tools

For fuel and operating fluids that only meet the minimum requirements, it is possible that the oil service life may differ from that of the Liebherr recommendation.

5.3.9 Pump distributor gear oils

Machine without pump distributor gear oil cooler

Liebherr recommendation

Ambient temperature	Description
-25 to 50 °C	Liebherr Hypoid 85W-140 EP
-30 to 50 °C	Liebherr Gear Basic 90 LS
-30 to 50 °C	Liebherr Gear Hypoid 90 EP
-40 to 50 °C	Liebherr Syntogear Plus 75W-90

Tab. 107: Liebherr recommendation

Minimum quality requirements

Specification
API: GL-5
MIL-L: 2105 D or E, PRF-2105 D or E

Tab. 108: Minimum quality requirements

If gear oils from other manufacturers are used, information on change intervals must be obtained from respective manufacturer or supplier.

For fuel and operating fluids that only meet the minimum requirements, it is possible that the oil service life may differ from that of the Liebherr recommendation.

Machine with pump distributor gear oil cooler

Liebherr recommendation

Ambient temperature	Description
5 to 50 °C	Liebherr Hypoid 85W-140 EP
-5 to 50 °C	Liebherr Gear Basic 90 LS
-5 to 50 °C	Liebherr Gear Hypoid 90 EP
-20 to 50 °C	Liebherr Syntogear Plus 75W-90

Tab. 109: Liebherr recommendation

5.6 General maintenance

5.6.1 Welding

- ▶ For procedure on repair welding, refer to service manual under Chapter 140.
- ▶ Document repair case in repair report, refer to service manual under Chapter 140.
- ▶ Only have repair welding performed by certified specialist welding operation.

5.6.2 Corrosion-proofing piston rods

Corrosion-proofing piston rods prevents corrosion.



Note

Liebherr recommends:

- ▶ Use Liebherr Chrome Protect.

NOTICE

Corrosion!

Damage to piston rods.

- ▶ Check corrosion-proofing daily.
- ▶ Where necessary, apply corrosion inhibitor.



Note

Corrosion in maritime areas or corrosive environments!

- ▶ When in storage, use acid-free corrosion inhibitor grease as corrosion inhibitor.
- ▶ For non-moved piston rods, use acid-free corrosion inhibitor grease as corrosion inhibitor.
- ▶ Remove grease before retracting the piston rods.
- ▶ For moved piston rods, use Liebherr Chrome Protect as the corrosion inhibitor.
- ▶ Replace corrosion inhibitor at susceptible areas after each cleaning.

Machine in operation

- ▶ Fully retract all piston rods every day.
 - ▷ Piston rods are covered with a protective film of hydraulic oil.

If it is not possible to retract piston rods fully into cylinders:

- ▶ Apply corrosion inhibitor to exposed areas of piston rods.

If hydraulic cylinder is not moved for a long time:

- ▶ Apply corrosion inhibitor to exposed areas of piston rods.
- ▶ Check corrosion protection on little-moving hydraulic cylinders every day.

Parking or transporting machine

- ▶ Retract piston rods fully into cylinders.

- ▶ Clean dipstick **1** with clean lint-free cloth.
- ▶ Insert dipstick **1** fully.
- ▶ Pull out dipstick **1** again.
- ▶ Check that oil level is between **min** mark and **max** mark on dipstick **1**.

NOTICE

Incorrect mixture of engine oils!
Damage to diesel engine.

- ▶ Do not mix engine oils.

NOTICE

Unapproved oil!
Damage to diesel engine.

- ▶ Exclusively use oil in line with Liebherr specification.

- ▶ Observe difficulty factors and oil specification ([For more information see: 5.3.4 Engine oils, page 279](#)).

If oil level is below **min** mark:

- ▶ Unlock oil fill cover **2**.
- ▶ Remove oil fill cover **2**.
- ▶ Fill oil through oil fill pipe **3** until **max** mark is reached.
- ▶ Clean oil fill cover **2** with clean lint-free cloth.
- ▶ Lock oil fill cover **2**.

5.8.3 Fuel pre-filter: Draining water

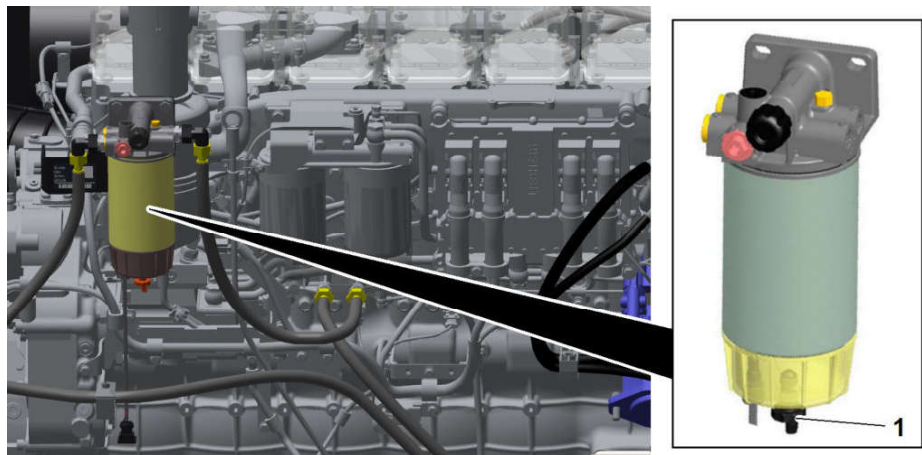

Fig. 894: Draining water

- 1** Water drain tap

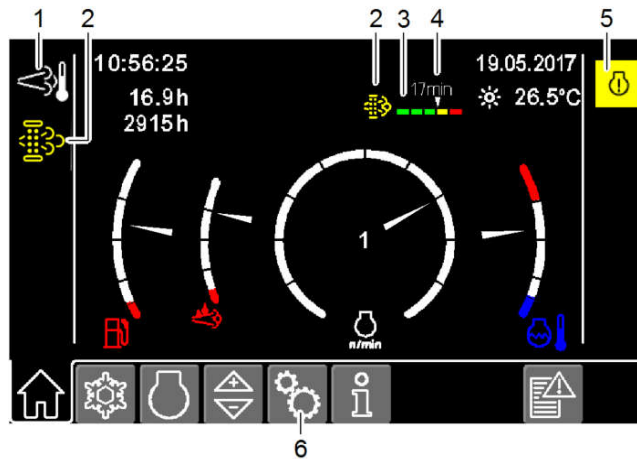

Fig. 900: Start page menu

- | | | | |
|---|--|---|---|
| 1 | Increased exhaust temperature status symbol | 4 | Remaining filter regeneration time |
| 2 | Diesel particulate filter contaminated status symbol | 5 | Prewarning: Control error of diesel engine warning symbol |
| 3 | Contamination level of diesel particulate filter | 6 | Function settings menu |

Contamination level of diesel particulate filter

NOTICE

Contaminated diesel particulate filter!
Damage to diesel engine.

- ▶ Shut off diesel engine.
- ▶ Have diesel particulate filter checked by Liebherr customer service.

The bar chart display on the display shows the contamination level of the diesel particulate filter in five stages. The pointer above the bar chart display indicates the degree of contamination of the diesel particulate filter.

	Stage 1	Stage 2	Stage 3	Stage 4	Stage 5	Stage 5
Stage shown on the display						
Activation of filter regeneration	—	—	—	Manual	Manual	Manually by Liebherr customer service
Deactivating or cancelling filter regeneration	—	—	—	Deactivating or cancelling possible	Cancelling possible	Cancelling possible

Tab. 120: Contamination level of diesel particulate filter

LHB/12200354/01/2020-09-03/en

5.12.2 Tightening track

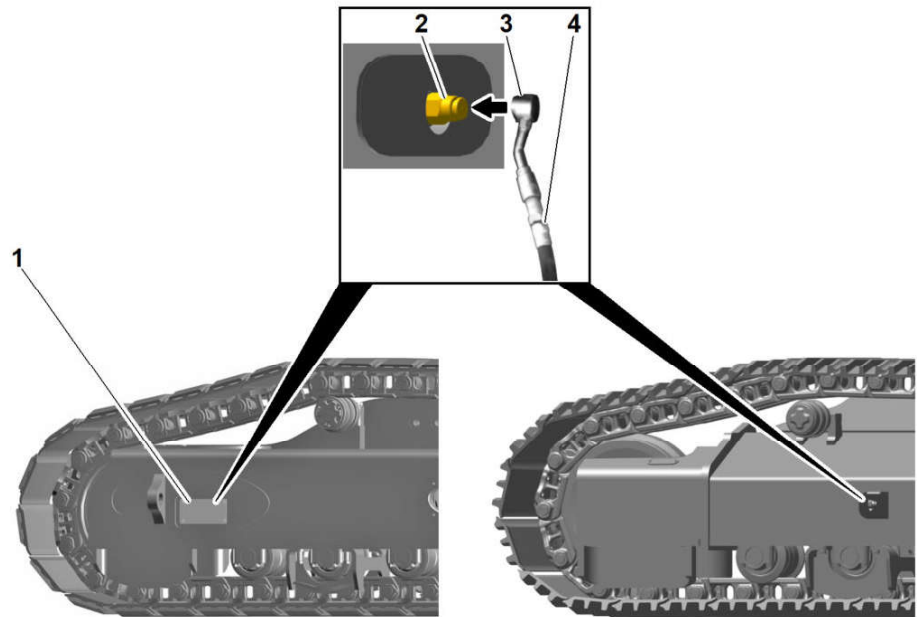

Fig. 940: Tightening track

- | | | | |
|---|------------------------|---|------------------------|
| 1 | Cover (type dependent) | 3 | Grease fitting adapter |
| 2 | Grease fitting | 4 | Grease gun hose |

Make sure the following preconditions are met:

- Machine is parked on level and firm ground.
- Machine is secured against rolling away.

- ▶ Clean track.
- ▶ Remove objects jammed in track.

If cover 1 is installed:

- ▶ Remove cover 1.
- ▶ Clean grease fitting 2.
- ▶ Connect supplied grease fitting adapter 3 to grease gun hose 4.
- ▶ Connect grease fitting adapter 3 to grease fitting 2.
- ▶ Inject grease until track tension corresponds to specifications. (For more information see: [5.12.1 Checking track tension, page 334](#))
- ▶ Attach cover 1.

Troubleshooting

Track tension is not increasing?

Grease fitting or tensioning unit is damaged.

- ▶ Replace grease fitting and tensioning unit. For procedure see service manual under chapter 130.

If service manual cannot be accessed:

- ▶ Have repairs performed by Liebherr customer service.

Undercarriage (option)

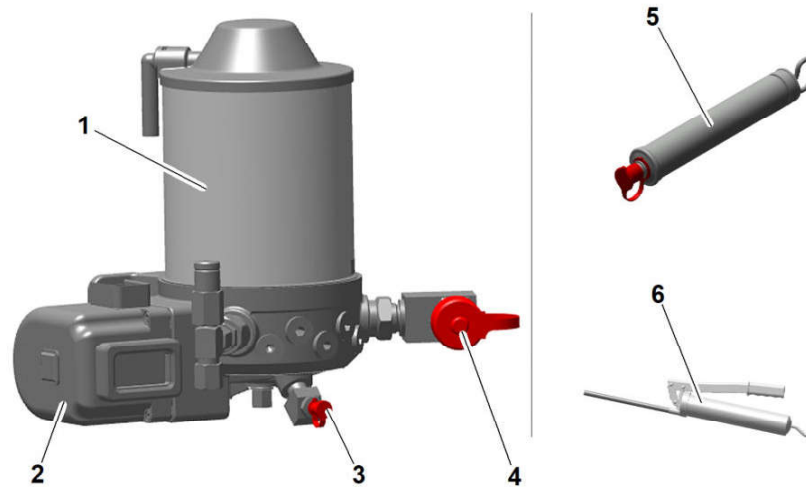

Fig. 952: Filling grease container

- | | | | |
|---|------------------|---|----------------------|
| 1 | Grease container | 4 | Filling pump adapter |
| 2 | Lubricating pump | 5 | Filling pump |
| 3 | Grease nipple | 6 | Grease gun |

NOTICE

Incorrect filling of grease container!
Machine damage.

- ▶ Exclusively fill grease container through adapter or grease nipple.

- ▶ Insert grease cartridge in filling pump 5.
- ▶ Connect filling pump 5 to filling pump adapter 4.
- ▶ Press contents of grease cartridge into grease container 1.

If no filling pump 5 is available:

- ▶ Fill grease container 1 with grease gun 6 via grease nipple 3.

5.15.2 Checking lubrication of bearings (grease collar)

- ▶ Check all connected lubricating points for sufficient lubricant distribution.

CLICK HERE TO **DOWNLOAD** THE COMPLETE MANUAL

- Thank you very much for reading the preview of the manual.
- You can download the complete manual from: www.heydownloads.com by clicking the link below



- Please note: If there is no response to CLICKING the link, please download this PDF first and then click on it.

CLICK HERE TO **DOWNLOAD** THE COMPLETE MANUAL