

en

Operator's manual

Wheel loader

Document ID

	ORIGINAL OPERATOR'S MANUAL
Order number:	12239307
Issued:	2020-02-03
Version:	07
Author:	LBH / Technical Documentation Department

Product ID

Manufacturer:	Liebherr-Werk Bischofshofen GmbH
Type:	L 580
Type no.:	1760 (USA / CAN)
From Serial no.:	48644

Contact

Liebherr-Werk Bischofshofen GmbH
Dr. Hans Liebherr-Straße 4
A – 5500 Bischofshofen

CLICK HERE TO **DOWNLOAD** THE COMPLETE MANUAL

- Thank you very much for reading the preview of the manual.
- You can download the complete manual from: www.heydownloads.com by clicking the link below



- Please note: If there is no response to CLICKING the link, please download this PDF first and then click on it.

CLICK HERE TO **DOWNLOAD** THE COMPLETE MANUAL

3.3.8	Forklift	216
3.3.9	2in1 steering	218
3.3.10	Joystick steering	220
3.3.11	Roof camera for front space monitoring	228
3.3.12	Skyview 360°	230
3.4	Working methods	237
3.4.1	Picking up material	237
3.4.2	Transporting and moving material	238
3.4.3	Emptying the working attachment	239
3.4.4	Handling materials with high dump buckets	240
3.4.5	Loading with clamp buckets	241
3.4.6	Grading work	241
3.4.7	Removing material from a slope or wall	242
3.4.8	Loading a transport vehicle	244
3.4.9	Excavation	246
3.5	Fitting and removing the attachment	248
3.5.1	Hydraulic connections for hydraulic working attachment	248
3.5.2	Removing the working attachment from the quick coupler	248
3.5.3	Fitting working attachments to the quick coupler	250
3.6	Transport	254
3.6.1	Transporting the machine	254
3.6.2	Transport safety retainer	258
3.7	Emergency modes	260
3.7.1	Lowering the lift arms if the diesel engine fails	260
3.7.2	Recovering and towing the machine	261
3.7.3	Emergency steering	265
3.7.4	Jump starting procedure	266
3.7.5	Jump start aid	267
3.7.6	Emergency actuation of parking brake	269
4	Malfunctions	273
4.1	Servicecodes	273
4.1.1	Service code indicator in the display	273
4.2	Problems - Cause - Remedy	274
4.2.1	Warning symbols	274

1.2.7 Axles

- All-wheel drive
- Axle ratio: planetary drives in wheel hubs

Front axle

Rigidly mounted planetary axle.

Description	Unit	Value
Track width	mm	2230
	ft-in	7' 4"
Automatic self-locking differential	%	45

Rear axle

Oscillating planetary axle.

Description	Unit	Value
Track width	mm	2230
	ft-in	7' 4"
Automatic self-locking differential	%	45
Angle of articulation to each side	°	13
Maximum obstacle height (standard tyres), with all four wheels on ground.	mm ft-in	473 1' 7"

1.2.8 Braking

The brake systems comply with the roadworthiness certification regulations.

Service brake

- Self-arrest of travel drive, acting on all four wheels.
- Hydraulic pump accumulator brake system with wet disc brakes (two separate brake circuits)

Parking brake

Electrohydraulically actuated spring accumulator disc brake on the transmission.

1.2.9 Steering

Type:

- Load sensing swash plate variable displacement pump with pressure cut-off and flow regulator.
- Central articulated joint with two dual-action steering cylinders with shock absorbers.

Emergency steering: Electrohydraulic emergency steering system

- H) In practice, the bucket capacity can be around 10% greater than as calculated using the ISO 7546 standard. The bucket filling level depends on the type of material.

1.2.22 Complete machine with loading bucket (industrial lift arms)

Values stated refer to machine:

- In standard version
- With 26.5R25 L3 tyres
- Including all lubricants
- With a full fuel tank
- With ROPS/FOPS cab and operator
- On level and stable ground



Note

Tyres and working attachments affect operating weight and tipping load.

► Note information about tyres and working attachment.

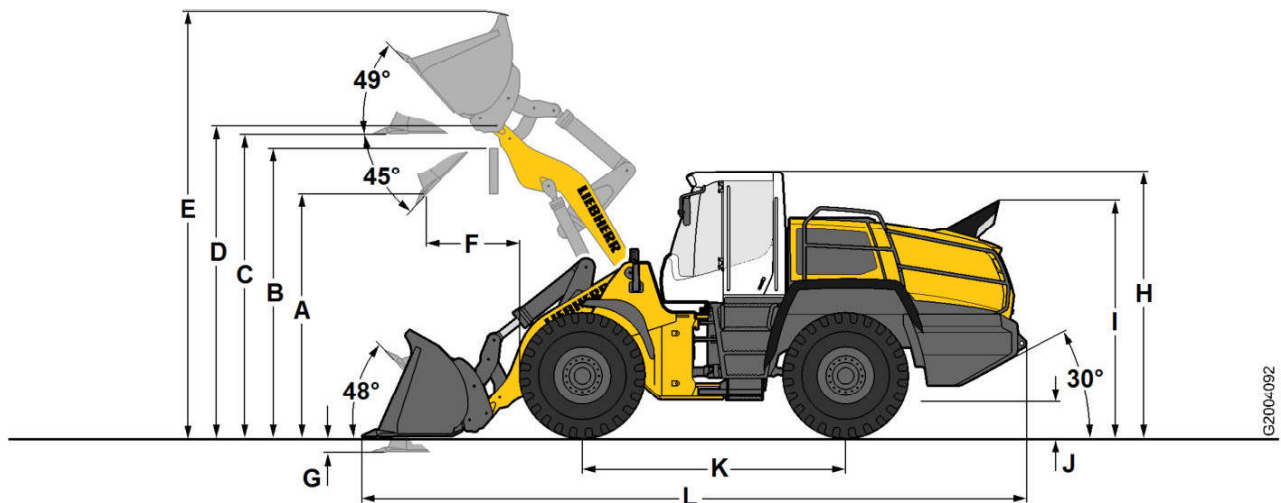

Fig. 5: Complete machine with loading bucket (industrial lift arms)

Designation	Unit	Value	
Hydraulic quick coupler		Yes	Yes
Load geometry		A)	A)
Bucket type		B)	B)
Cutting tool		C)	C)
Lift arm length	mm in	2900 9' 6"	2900 9' 6"
Bucket capacity as per ISO 7546 ^{D)}	m ³ yd ³	4.5 5.89	5.0 6.54
Bucket width	mm in	3000 9' 10"	3000 9' 10"

1.3.3 Manufacturer's warranty coverage

All emission related parts of 2011 and later nonroad engines, which are purchased in the United States of America, are warranted for a period of five years or 3,000 hours of operation, whichever occurs first. If any emission-related part on the engine is defective, the part will be repaired or replaced by an authorized Liebherr Dealer.

1.3.4 Owner's warranty responsibilities

- A nonroad compression-ignition engine owner is responsible for the performance of the required maintenance listed in the machine's Operation & Maintenance Manual. Liebherr recommends that the owner maintains a log book and retains all receipts covering maintenance on the nonroad engine, but Liebherr cannot deny warranty solely for the lack of receipts or for failure to ensure the performance of all scheduled maintenance.
- Liebherr may deny warranty coverage if the nonroad compression-ignition engine or a part thereof has failed due to abuse, neglect, improper maintenance, or unapproved modifications.
- The nonroad compression-ignition engine is designed to operate on Ultra low sulfur diesel fuel only. Use of any other fuel may result in the engine no longer operating in compliance with US Environmental Protection Agency (EPA) and California Air Resources Board (ARB) emission requirements.
- The owner is responsible for initiating the warranty process. The US Environmental Protection Agency and California Air Resources Board suggests that nonroad engines or machines be made available to an authorized Liebherr Dealer to perform warranty service on behalf of Liebherr as soon as a problem arises. The warranty repairs should be completed by the authorized Dealer as expeditiously as possible.

Questions in regard to warranty rights and responsibilities or the location of the nearest authorized Liebherr Dealer should be directed to Liebherr service department in Newport News, VA, (757) 245-5251.

1.3.5 Warranty coverage

Liebherr warrants any 2011 and later model year nonroad diesel engine certified for sale and registered in the United States of America and the State of California is designed, built, and equipped so as to conform to all applicable regulations adopted by the EPA and ARB. Liebherr warrants that such engine is free from defects in materials and workmanship which cause the failure of a warranted part to be identical in all material respects to the part as described in the engine manufacturer's application for certification for a period of five (5) years or 3,000 hours of operation, whichever occurs first. The warranty period begins on the date the engine or machine is delivered to an ultimate purchaser. Liebherr also warrants that any part that is on the warranted emission parts list of this warranty and installed as original equipment is free from defects in material and workmanship, which would cause this engine not to be in compliance with the emission standards adopted by the EPA and ARB for five (5) years or 3,000 hours, whichever occurs first. Except for any warranted part that is scheduled for replacement as required maintenance, if any warranted part fails during the period of warranty coverage, the part will be repaired or replaced by LCE at no charge to the owner by any authorized Liebherr Dealer. Any such part repaired or replaced during the warranty period will be warranted for the remaining warranty period. If any warranted part that is scheduled for replacement as required maintenance fails prior to the first scheduled replacement point for that part, that part will be repaired or replaced by

- Is able to guide a load.
- Has the necessary authorisation for attaching loads.
- The slinger has the necessary education (theoretical and practical) for the following:
 - Selecting the suitable slinging gear
 - Attaching slinging gear
 - Securing to prevent unintended disengaging of slinging gear
 - Avoiding damage to slinging gear
 - Spotting
 - Applying all necessary signal signs
- Is not under any physical or mental impairment that limits one of the prescribed requirements.
- Is not under the influence of alcohol.
- Is not under the influence of drugs.

2.3.8 Spotter

Responsibility

The spotter is responsible for the following:

- Wear personal protective equipment.
- Forward signals from slinger to operator.
- If the spotter is the only person for this purpose: Give instructions to operator.
- The spotter must be in the field of view of operator or have voice contact with the operator.

Requirement

The spotter has following qualification and skills:

- Has completed the legally specified minimum age.
- Physically and mentally capable of spotting and providing signals:
 - Satisfactory eyesight
 - Satisfactory hearing ability
 - Quick reactions
 - Is able to estimate distance, height and gaps.
- The spotter has following skills:
 - Is able to operate radio units.
 - Is able to give clear instructions on radio units.
 - Is able to guide a load.
 - Is able to ensure safe movement of load and machine.
- Has the necessary authorisation for giving signal signs.
- The spotter has the necessary education (theoretical and practical) for the following:
 - Spotting
 - Applying all necessary signal signs
- Is not under any physical or mental impairment that limits one of the prescribed requirements.
- Is not under the influence of alcohol.
- Is not under the influence of drugs.

2.4 Signs on the machine

There are various types of sign attached to your machine.

- To load and unload machine, use only sturdy, stable loading ramps.
- Make sure that width and angle of ramps match the gauge and climbing ability of machine.

Incorrect transport

- Park machine on level ground during preparation for transport (disassembly, cleaning).
- Secure machine against rolling away.
- Apply parking brake.
- Pull out ignition key.
- Leave operator's cab.
- All doors, windows and service access points are closed.
- Make sure that nobody is on the machine during transport.
- If necessary, dismantle a portion of working attachment from machine for duration of transport.
- Make sure that the road to be travelled is known.
- Make sure that all applicable limitations for width, height and weight are known.
- Drive carefully under electric cables and bridges.
- Drive carefully through tunnels.

2.7.4 Access to machine

















Injury

Incorrect entry and exit

- Clean dirt, oil, ice and snow from steps, ladders, anti-slip mats, handrails and handles.
- Enter and exit carefully on muddy roads, ice, snow, traffic on access roads and in narrow conditions.
- Regularly check steps, ladders, anti-slip mats, handrails and handles and have them repaired if necessary.
- Before entering machine, clean mud, grease, ice and snow from shoes and climbing aids.
- Put on gloves for secure grip.
- Do not climb up or down using tyres, wheel hubs or rims.
- When exterior influences (for example wind) make opening and closing the door more difficult: Always guide door with your hand.
- Make sure that the opened or closed door has engaged properly.
- If the machine is still moving: Do not stand up from the operator's seat.
- Never jump off machine.
- Enter and leave the machine exclusively using the access system.
- Do not use control elements as handles.
- Keep your face towards machine during entry and exit.
- Make sure you always have two hands and a foot or two feet and one hand in contact with the access system.
- After entering the operator's cab, find out about emergency exit.

If the machine has a cab elevation:

- Climb until the door is reached.
- When you reach door handle with your free hand: Open door.
- Continue climbing.

Key	Designation	Key	Designation
	Auto lift arm position ^{A)}		Auto lowering ^{A)}
	Central lubrication system (option)		Vmax (speed restriction)
	Emergency steering		Float position ^{B)}
	Bucket return-to-dig ^{A)}		Ride control ^{A)}
	Increase tractive force ^{A)}		Reduce tractive force ^{A)}
	Automatic heating, air conditioning		Recirculated air
	Increase the blower speed		Reduce the blower speed
	Temperature up button		Temperature down button
	Defrost mode		

Tab. 19: Control unit

A) The setting remains stored after the ignition is switched off.

B) The memory function for the setting is optional.

3.1.4 Switches and buttons

The switches and buttons are used to activate and deactivate various functions on the machine. When a function is activated, the corresponding LED lights up.

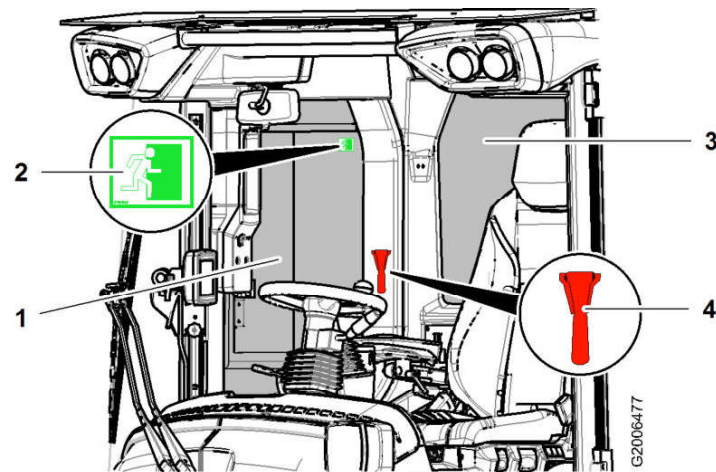

Fig. 102: Using the emergency hammer

- | | | | |
|---|----------------------|---|------------------|
| 1 | Side window | 3 | Rear window |
| 2 | Emergency exit decal | 4 | Emergency hammer |

- ▶ Turn off the engine.
 - ▷ All travel and working functions are switched off.
- ▶ Depending on the emergency situation: Break the side window 1 or the rear window 3 using the emergency hammer 4.
- ▶ Leave the cab through the broken window.

3.2.6 Fire extinguisher

This equipment is optional.



Note

Use, safety and inspection of the fire extinguisher!

- ▶ Find out about fire alarm options and fire fighting equipment on the site.
- ▶ Make sure you know where the fire extinguisher is located and how to use it.

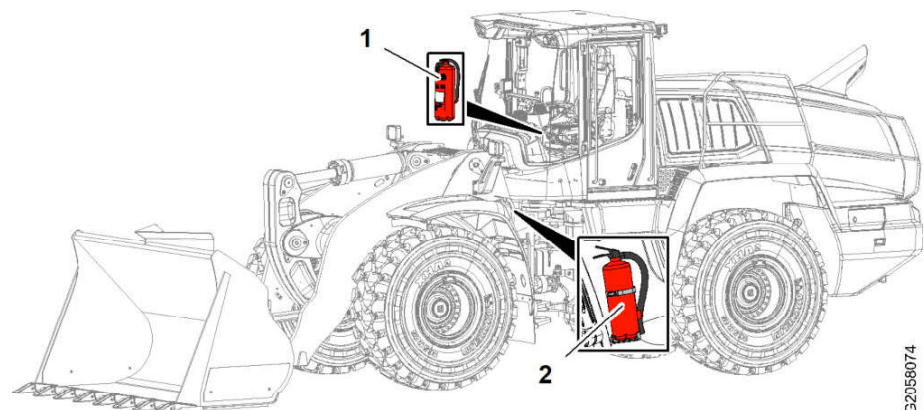

Fig. 103: Fire extinguisher

- | | | | |
|---|----------------------------------|---|-----------------------------------|
| 1 | Fire extinguisher 2 kg (4.41 lb) | 2 | Fire extinguisher 6 kg (13.23 lb) |
|---|----------------------------------|---|-----------------------------------|

When installing a fire extinguisher at a later point:

- Find out about the mounting options: contact Liebherr customer service.

- With acoustic warning device (warning sound in operator's cab) (option)
- With acoustic (warning sound in operator's cab) and visual warning device (option)

**WARNING**

Always wear a safety belt!
Injury.

- ▶ Always wear safety belt before putting machine into service.

Fastening safety belt

Make sure that following requirements are fulfilled:

- Condition, function and fastening have been checked.
- Damaged parts have been replaced.
- The safety belt is not twisted.
- A proper seating position is adopted.

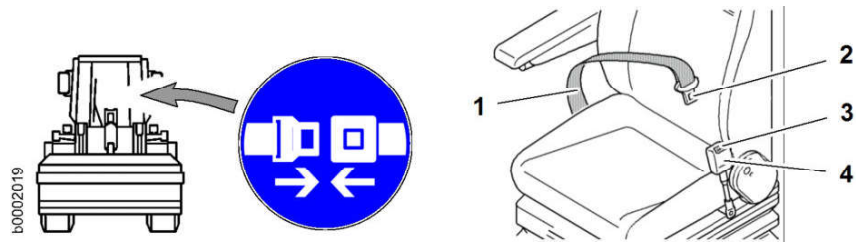

Fig. 148: Safety belt

- 1 Strap
- 2 Lug

- 3 Release button
- 4 Belt lock

- ▶ To fasten the safety belt: pull the strap 1 over your lap and lock the lug 2 into the belt lock 4.

- ▶ To release the safety belt: press the release button 3.

3.2.9 Steering wheel

By adjusting the steering column you can change the height of the steering wheel and the distance from your body. This adjustment is continuous.

**WARNING**

Uncontrolled steering movements!
Risk of injury.

- ▶ Only adjust the steering wheel when the engine is switched off.

Adjusting the distance from the steering wheel to your body**NOTICE**

Collision of steering wheel with windscreen!
Damage to the operator's cab.

- ▶ Ensure that when unlocking the steering column, the steering wheel does not hit the windscreen.

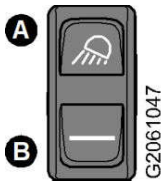
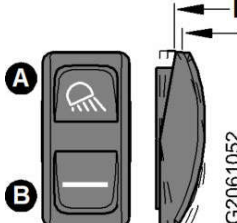
Switch	Switch positions
	A Front working headlights B OFF
	A-I Rear working headlights for reverse travel A-II Rear working headlights B OFF

Tab. 29: Working headlights

Indicator lights

Make sure that following requirements are met:

- The electrical system of the machine is switched on.

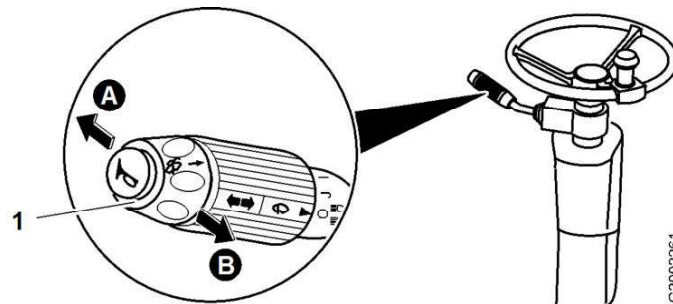

Fig. 166: Indicator lights

- 1 Steering-column switch
 A Right indicator light

- B Left indicator light

- ▶ To switch on the right indicator light: push the steering-column switch 1 in direction A.
- ▶ To switch on the left indicator light: push the steering-column switch 1 in direction B.

Flashing beacon

This equipment is optional.

The flashing beacon still works when the ignition key has been taken out.

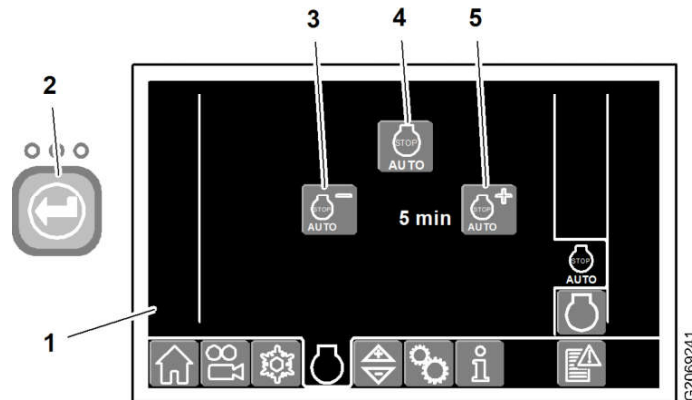

Fig. 222: Automatic engine shut down

- | | |
|---|--|
| <p>1 Confirmation required status symbol</p> <p>2 Confirmation key</p> <p>3 Reduce engine shut-off time</p> | <p>4 Activate and deactivate automatic engine shut down</p> <p>5 Increase engine shut-off time</p> |
|---|--|

- ▶ Press button **3** or **5** to adjust the engine shut-off time.
 - ▷ The status symbol **1** flashes.
- ▶ Press the key **2** to confirm the engine shutdown time.
- ▶ Press the button **4** to activate/deactivate *automatic engine shut down*.
 - ▷ The status symbol **1** flashes.
- ▶ Press the key **2** to confirm the *automatic engine shut down*.
 - ▷ If *automatic engine shut down* is activated: the button **4** is green. The *automatic engine shut down* symbol appears on the start page.



Note

Engine shut down deactivates if the cab door is opened during the engine shut down time!

- ▶ Activate engine shut down: close cab door and carry out operator activity, for example, press accelerator pedal briefly.

Checking diesel engine oil level

(For more information see: [Checking the oil level on the display, page 328](#))

Menu: System settings

Menu call:

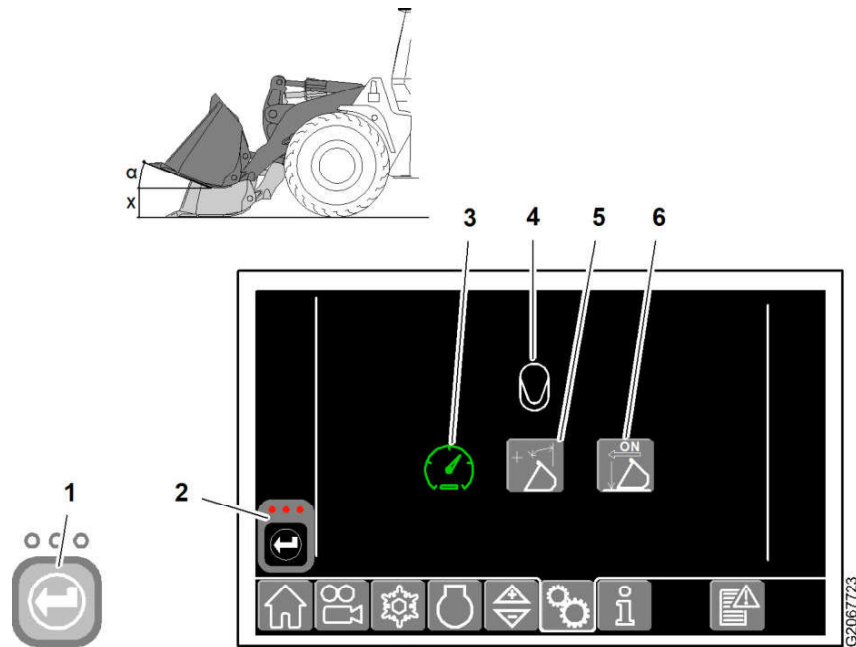

Fig. 264: Adjusting ride control

- 1 Confirmation key
- 2 Confirmation required status symbol
- 3 Ride control activated according to speed (default setting)
- 4 Ride control symbol
- 5 Ride control activated with working attachment tilted in button
- 6 Ride control activated in loading position button
- α Maximum angle of loading position
- X Maximum height of loading position



Note

Outside **both** tolerances, α and X, the working attachment is no longer in loading position!

- ▶ Press button 5 or 6.
 - ▷ Symbol 2 flashes.
- ▶ Press key 1.
 - ▷ Selected mode is active.

Indicator in the display	Ride control activated according to speed (default setting)
	Ride control is activated or deactivated above the loading position at the following travel speeds: Forward travel: on 7 km/h (4 mph), off 6 km/h (4 mph) Reverse travel: on 4 km/h (2 mph), off 3 km/h (2 mph) Ride control is deactivated in the loading position regardless of the travel speed.
Example: reverse loading operations, material handling	

Tab. 36: Ride control activated according to speed (default setting)

LBH/12239307/07/2020-02-03/en



Note

Acoustic warning sound is re-activated after ignition **OFF / ON**.

- ▶ Deactivate personnel detection: press button **2** or button **3**.
 - ▷ Personnel detection is deactivated for forward travel direction or neutral travel direction.

Menu: information

Menu call: 

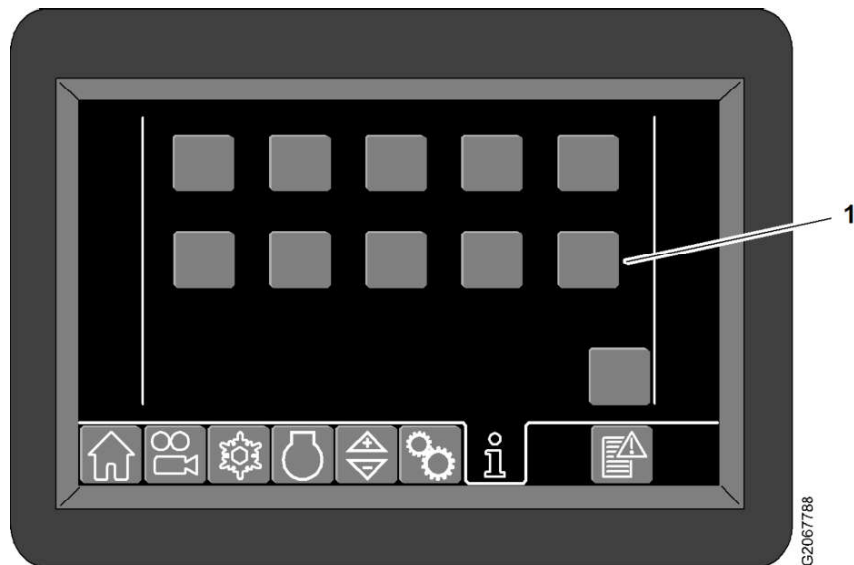





Fig. 282: Menu: information

1 Buttons

Buttons	Designation
	Fuel consumption indicator
	Tachometer
	Expert mode (option)
	Tyre pressure monitoring system (option)

Tab. 41: Buttons

LBH/12239307/07/2020-02-03/en

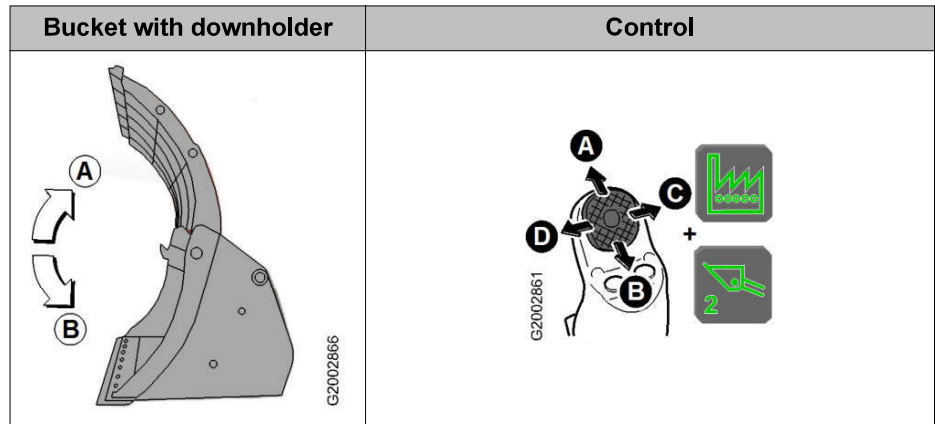

Tab. 46: Bucket with downholder control system

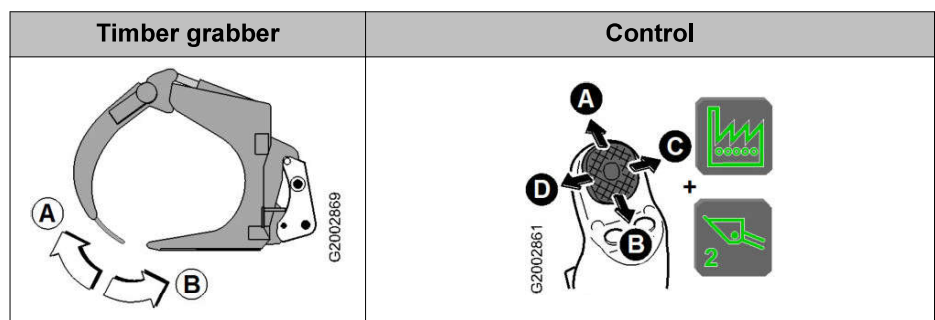

Tab. 47: Timber grabber control

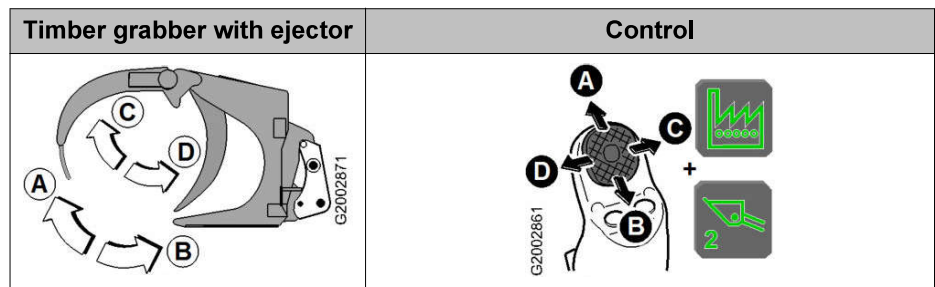

Tab. 48: Timber grabber with ejector control

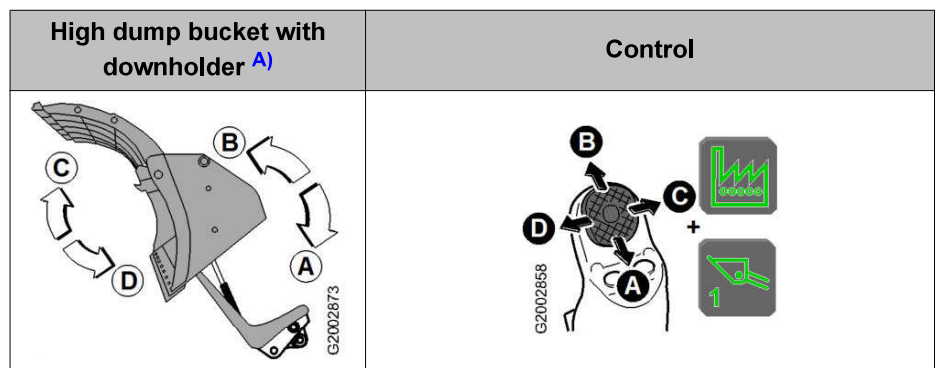

Tab. 49: High dump bucket with downholder control

LBH/12239307/07/2020-02-03/en

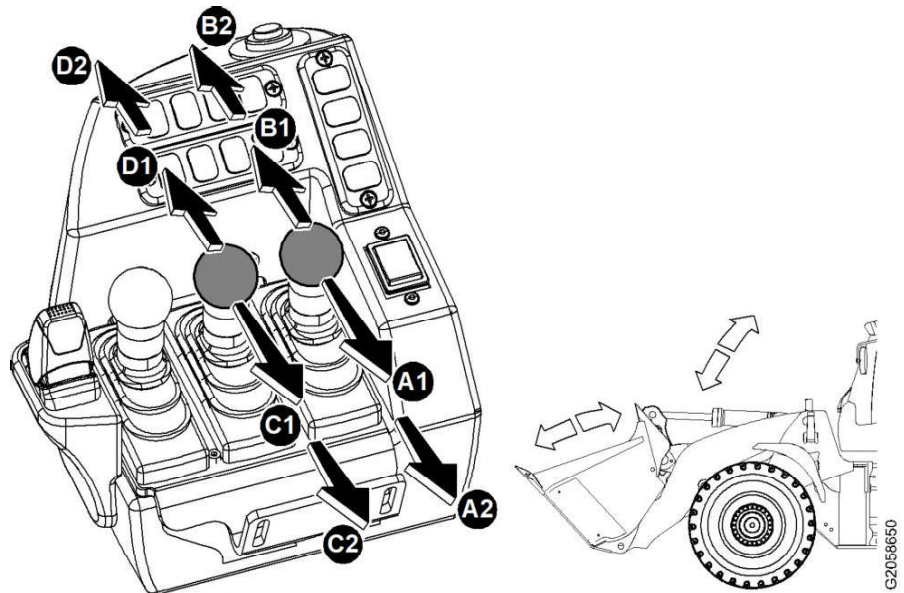

Fig. 341: Controlling the working attachment

Direction of lever movement		Working attachment function	
A1	Back to action point	Raise the lift arms.	Standard
A2	Back to limit	Auto lift arm position	Standard
B1	Forward to action point	Lower the lift arms.	Standard
B2	Forward to limit	Float position	Standard
		Auto lowering	Standard
C1	Back to action point	Tilt bucket in.	Standard
C2	Back to limit	Bucket return-to-dig	Standard
D1	Forward to action point	Tilt the bucket out.	Standard
D2	Forward to limit	Bucket return-to-dig	Standard

Tab. 52: Controlling the working attachment

Selecting the travel direction

The travel direction cannot be selected while the parking brake is engaged.

Make sure that following requirements are met:

- Accelerator pedal is not pressed.
- The parking brake is released.

LBH/12239307/07/2020-02-03/en

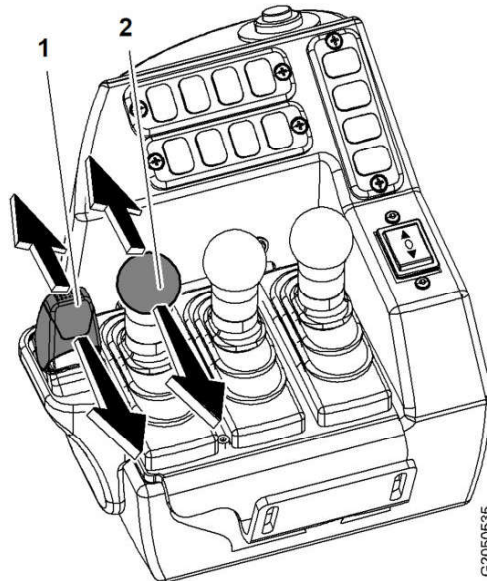

Fig. 359: Controlling the hydraulic working attachment

- 1 4th function lever
- 2 3rd function lever

- ▶ Press lever 1 or lever 2 in desired direction.
 - ▷ The hydraulic working attachment is controlled (for example, opening and closing a timber grabber).

Multi-lever control function settings

Menu call:  > 

The following function settings can be selected:

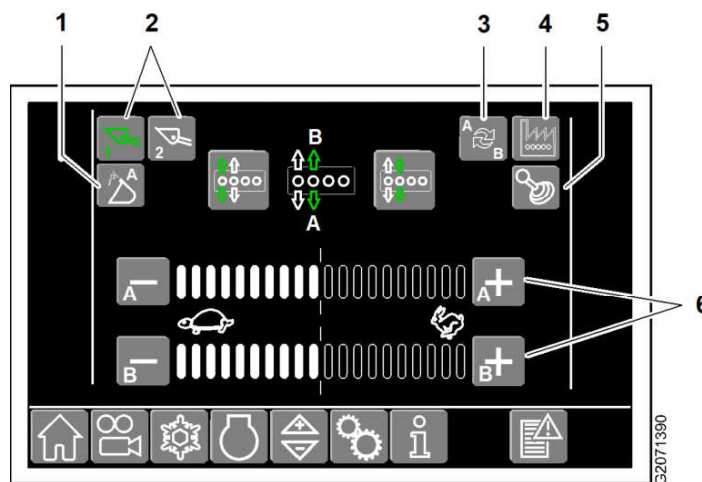
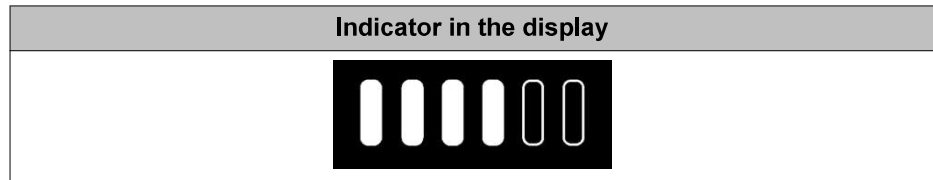

Fig. 360: Multi-lever control function settings

Item	Designation
1	Automatic return 3rd function key (For more information see: Settings for automatic return 3rd function , page 162)

LBH/12239307/07/2020-02-03/en









Tab. 67: Display: fan regulation

Adjusting the air distribution

The function can only be deactivated on the display.

Make sure that following preconditions are met:

- The outlet nozzles are open.

Operation on the display		Indicator in the display	
	<i>Head level button</i>		<i>Head level indicator</i>
	<i>Mid-level button</i>		<i>Mid-level indicator</i>
	<i>Foot level button</i>		<i>Foot level indicator</i>

Tab. 68: Adjusting the air distribution

3.2.21 Rear window heater and exterior mirror heater (option)

This function is only available when the ignition is on.

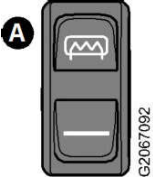
Button	Switch positions
	A Rear window heater, exterior mirror heater

Tab. 69: Rear window heater and exterior mirror heater (option)



Note

Rear window heater and exterior mirror heater switch off automatically after 15 minutes.

LBH/12239307/07/2020-02-03/en

▷ The flashing light **4** is switched off.

Flashing beacon on the rear of the machine

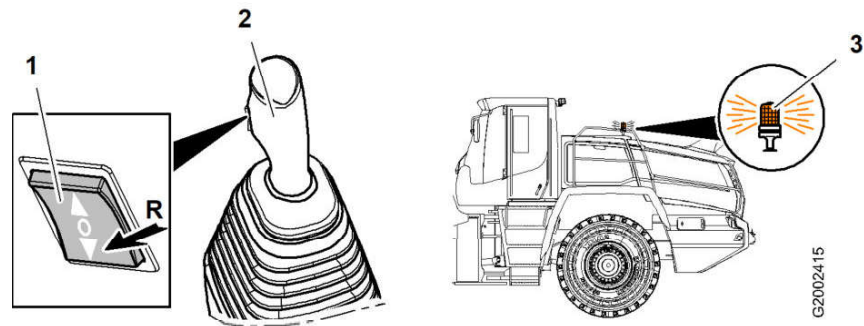

Fig. 405: Flashing beacon on the rear of the machine

- | | |
|----------------------------------|-----------------------------------|
| 1 Travel direction switch | 3 Flashing beacon |
| 2 Control lever | R Reverse travel direction |

- ▶ Press the switch **1** in travel direction **R**.
 - ▷ Reverse travel direction symbol is shown in display.
 - ▷ The beacon **3** is switched on.

Flashing beacon on the operator's cab

Selectable functions:

- Flashing beacon active when travelling in reverse
- Flashing beacon in continuous operation
- Flashing beacon off

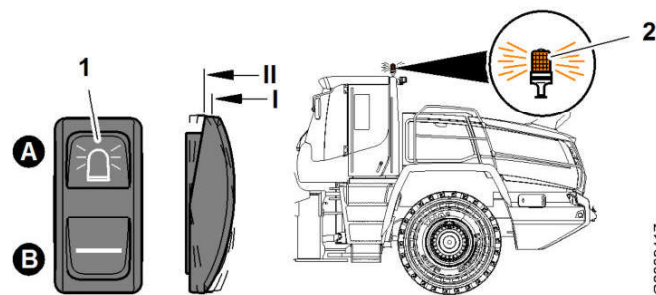

Fig. 406: Flashing beacon on the operator's cab

- | | |
|------------------------|--------------------------|
| 1 Beacon switch | 2 Flashing beacon |
|------------------------|--------------------------|

Flashing beacon active when travelling in reverse

- ▶ Push the switch **1** from position **A** to position **I**.
 - ▷ The flashing beacon **2** is active when travelling in reverse.

Flashing beacon in continuous operation

- ▶ Push the switch **1** from position **A** to position **II**.
 - ▷ The flashing beacon **2** is continuously active.

Flashing beacon off

CLICK HERE TO **DOWNLOAD** THE COMPLETE MANUAL

- Thank you very much for reading the preview of the manual.
- You can download the complete manual from: www.heydownloads.com by clicking the link below



- Please note: If there is no response to CLICKING the link, please download this PDF first and then click on it.

CLICK HERE TO **DOWNLOAD** THE COMPLETE MANUAL

3.3.3 Travel mode

Preparations for travel mode

Make sure the following preconditions are met:

- Machine is in operating position. (For more information see: [Putting the machine in the operating position, page 187](#))
- The mirrors and other visual aids (such as the reversing camera) are adjusted for the best possible all-round view. (For more information see: [2.7.6 Visibility, page 62](#))
- All lighting equipment has been checked and correctly adjusted. (For more information see: [5.12.1 Checking function of the lighting and horn, page 361](#))
- The steering system and service brake have been tested.
- The diesel engine has started.



WARNING

Always wear a safety belt!
Injury.

- ▶ Always wear safety belt before putting machine into service.

Transmission warm-up phase

At outside temperatures around freezing point, the transmission has to be brought up to operating temperature in order to operate the machine at full power.

There are two warm-up phases, depending on the gear oil temperature:

- Stationary warm-up phase: gear oil temperature below $-2\text{ }^{\circ}\text{C}$ ($28\text{ }^{\circ}\text{F}$)
- Travel mode warm-up phase: gear oil temperature between $-2\text{ }^{\circ}\text{C}$ ($28\text{ }^{\circ}\text{F}$) and $10\text{ }^{\circ}\text{C}$ ($50\text{ }^{\circ}\text{F}$)



Note

Gear oil temperature below $-2\text{ }^{\circ}\text{C}$ ($28\text{ }^{\circ}\text{F}$)!
Driving is not possible.

- ▶ Bring the transmission up to operating temperature.

Stationary warm-up phase

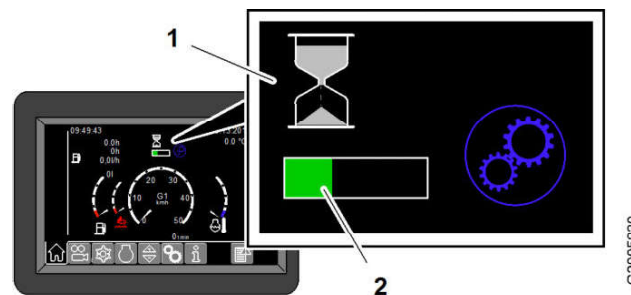

Fig. 414: Stationary warm-up phase

- 1 Stationary warm-up phase 2 Warm-up phase status

- ▶ Start diesel engine.
 - ▷ The machine cannot be driven.
 - ▷ The stationary warm-up phase 1 indicator appears in the display.
 - ▷ The diesel engine automatically begins with the stationary warm-up phase.

- ▶ Contact Liebherr customer service.

If you leave the machine with the diesel engine running after stopping:



DANGER

Beware of the machine rolling away!
There is a risk of fatal injury.

- ▶ Secure the machine against rolling away.

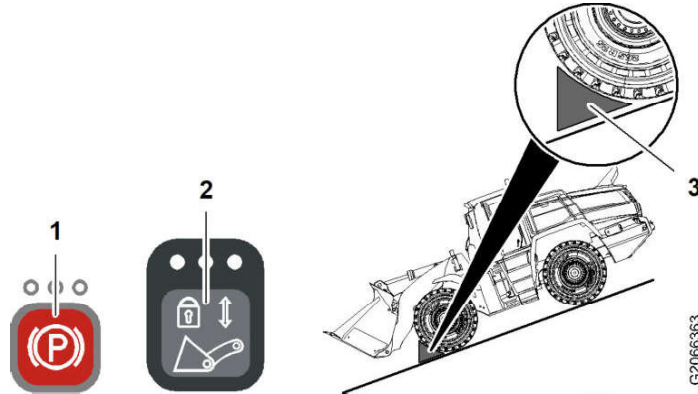

Fig. 429: After the machine stops

- | | |
|--|-----------------|
| <p>1 Parking brake key</p> <p>2 Working hydraulics lockout key</p> | <p>3 Chocks</p> |
|--|-----------------|

- ▶ Activate the parking brake using the key 1.
 - ▷ Parking brake symbol is shown in display.
 - ▷ The parking brake is engaged.
 - ▷ The travel direction is switched to neutral.
- ▶ Press the key 2 to activate the working hydraulics lockout.
 - ▷ Working hydraulics lockout symbol is shown in display.
 - ▷ Working hydraulics lockout is activated.
- ▶ Secure the machine with chocks 3.
- ▶ Always supervise the machine.

3.3.4 Driving on public roads

Always observe national regulations for driving on public roads!

Before driving on public roads, find out about the route (roads, bridges, tunnels, underpasses, bottlenecks etc.) and any weight limits, bridge loads, width and height restrictions that apply.



DANGER

Long journeys at high speed without a break!
Burst tyres, overheated drive components.

- ▶ After driving at 40 km (24.85 mi) or after driving for an hour without a break, stop the machine for at least 30 minutes (30 min).

Make sure that the following requirements are fulfilled:

- The requirements for permission to drive on public roads are met.
- You are familiar with the relevant safety regulations.

- ▶ Move the control lever **2** to the limit in direction **A2**.
 - ▷ The lift arms are automatically raised to the set kick-out position.

If the process has to be stopped:

- ▶ Move the control lever **2** in the opposite direction.

To deactivate the auto lift arm position function:

- ▶ Press key **1**.
 - ▷ The LEDs go out.
 - ▷ The auto lift arm position function is deactivated.

To define the work application:



Note

Shut-off heights can be saved for two different work applications (working attachments).

- ▶ Move the lift arms to the required position within the range **X**.
 - ▷ The button **7** lights up green.
- ▶ Press button **5** or **6**.
 - ▷ The symbol **4** and the selected button flash.
- ▶ Press key **3**.
 - ▷ The selected button lights up green.

To save the kick-out position:

- ▶ Press button **7**.
 - ▷ Symbol **4** flashes.
- ▶ Press key **3**.
 - ▷ The kick-out position is saved.

Auto lowering

Menu call:  > 

Auto lowering allows lift arms to be actively moved to a stored position. The factory setting for the kick-out position can be changed if necessary.

In auto lowering, a distinction is made between two variants:

- Auto lowering with bucket return-to-dig with the bucket tilted out
- Auto lowering with bucket return-to-dig with the bucket tilted in (option)



Note

When auto lowering is activated, the bucket return-to-dig function is automatically executed.

- ▶ Familiarise yourself with the working attachment in a secure area.

Procedure for saving the shut-off height of auto lowering:

1. Define the work application.
2. Save auto lowering.

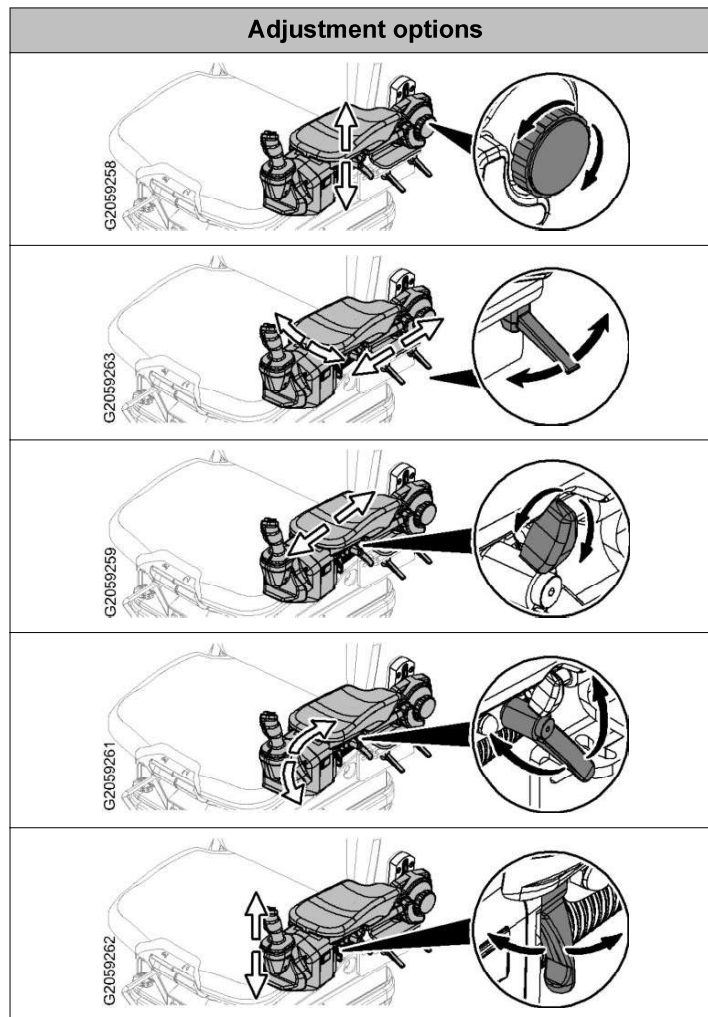

Tab. 76: Adjusting the left armrest

Activating joystick steering

Make sure that following requirements are met:

- The diesel engine has started.
- The transmission warm-up phase is completed.
- The parking brake is engaged.
- The on-road travel function is not activated.
- All levers and pedals are in the neutral position.

**DANGER**

Improper use!
Danger to life.

- ▶ Set display and other visual aids in such a way that they do not obscure each other and instead provide the best possible all-round view.
- ▶ Use the Skyview 360° option only at very low travel speeds (maximum walking speed).

The images from the cameras installed on the rear and the roof combine to form one common image (machine and machine surroundings) which provides a bird's eye view. With a glance at the additional display, the operator can view the immediate surroundings.

**Note**

The display has already been calibrated with the camera images ex-works!

- ▶ Do not change the position settings of the camera.

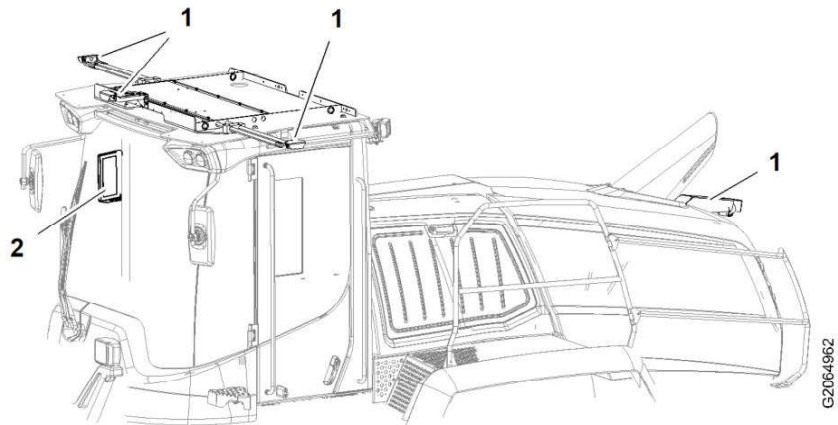

Fig. 467: Skyview 360°

1 Camera (4x)

2 Display Skyview 360°

Putting into service

The display has already been calibrated with the camera images ex-works; positions and angles of the camera have been precisely defined. For proper rendering of the close range of the machine, it is important to adopt these positions precisely.

Make sure that following preconditions are met:

- Machine is in maintenance position 1.
- Dirt or deposits on cameras have been removed.

3.4.5 Loading with clamp buckets

Buckets with downholder clamps are mainly used for loading light bulky goods, such as compost, branches and garbage.

The downholder clamp is only used to keep the load in the working attachment.

NOTICE

Unnecessary jolting of the working attachment!

Damage to the lift arms and lay the working attachment flat.

- ▶ Avoid unnecessary jolting.
-

Make sure that following requirements are met:

- Observe manufacturer's separate operating manual.
- The hydraulic lines of the clamp buckets are correctly connected.
- The functions have been checked.

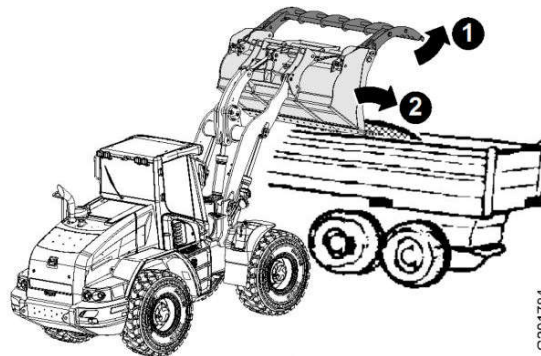

Fig. 478: Loading with clamp buckets

- ▶ Take up the loading material with the clamp bucket tilted in and the downholder clamp open.
- ▶ At the unloading site, open the downholder clamp and empty the loading material.

3.4.6 Grading work

There are two different ways to carry out grading work.

- In forward travel direction
- In reverse travel direction

Grading in forward travel direction

The following procedures are recommended to avoid any possible loss of traction.

- Do not work with a strong downwards pressure on the working attachment.
- Use *float position* function.

The quick coupler is fitted on the front of the attachment holder. It enables you to change the working attachment without getting out of the cab.

**DANGER**

Falling working attachment!
Danger to life.

- ▶ Make sure there is nobody in danger area.

**Note**

Changing the working attachment alters the total weight of the machine!

- ▶ In order to ensure the roll over protective structure of the operator's cab, do not exceed the permissible total weight of the machine (see identification plate).

**Note**

No equipment or attachments from other manufacturers may be installed or attached to the machine without prior written consent from Liebherr.

- ▶ The appropriate technical documentation should be made available to Liebherr for this purpose.

The following tasks must be carried out in the following sequence in order to safely remove the working attachment:

1. Connect and lock the working attachment
2. Checking that the working attachment is locked
3. Connect hydraulic lines. ⁷⁸⁾

Connecting and locking the working attachment

Make sure that following requirements are met:

- The quick coupler is completely unlocked.

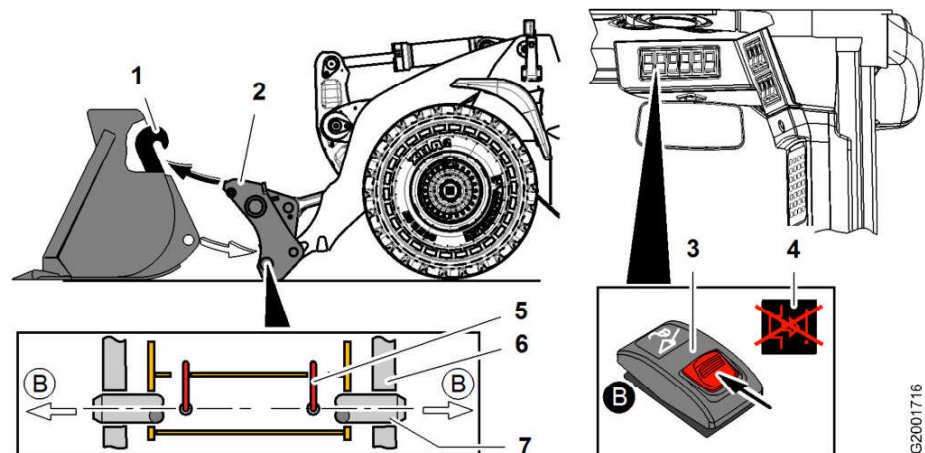

Fig. 493: Connecting and locking the working attachment

- | | |
|-----------------------------|-----------------------------|
| 1 Working attachment holder | 5 Locked position indicator |
| 2 Quick coupler | 6 Working attachment |

See next page for continuation of the image legend

⁷⁸⁾ If a working attachment with its own hydraulic supply is installed.

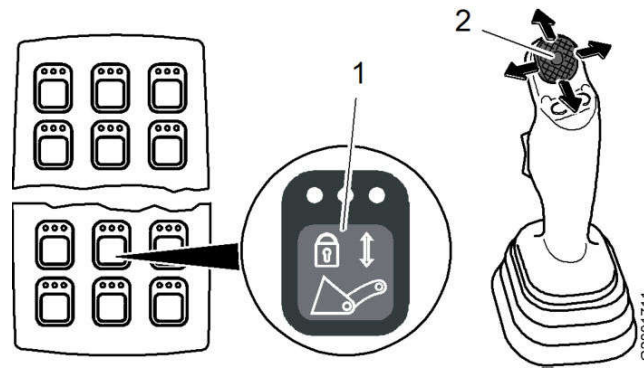

Fig. 503: Depressurising the hydraulics

1 Working hydraulics lockout key 2 Mini-joystick

- ▶ Switch on the ignition.
- ▶ Press and hold the key 1 while moving the mini-joystick 2 in the direction of the arrow several times.
 - ▷ The working attachment hydraulics have been depressurised.

3.7.2 Recovering and towing the machine

The machine has towing devices attached to it so that it can be quickly recovered from danger and towed away if it is unable to move under its own power. This means the machine can be towed for repairs to a suitable place for loading in accordance with the following instructions.

Instructions for recovering and towing a broken-down machine:

- Observe the local legal regulations.
- Use appropriate slinging gear and towing equipment of sufficient tensile strength.
- Avoid sudden loads on the slinging gear, towing equipment and recovery equipment.
- Make sure the load on the attachment points is evenly distributed.
- Avoid diagonal loads. Pull the machine, as straight forward or straight back as possible (maximum diagonal load = 20°).
- The maximum tensile load must not exceed the operating weight of the machine to be towed.
- The power and braking force of the towing machine must be sufficient for the route (uphill slopes).
- Towing machine and the machine being towed must be in the same weight class.
- The maximum permissible towing speed is 10 km/h (6 mph).
- The maximum permissible towing distance is 10 km (6.21 mi).
- For long distances, load the machine onto a transport vehicle or trailer.
- If the machine is stuck or there is no solid ground, a professional towing or recovery contractor must be called.



Note

Towing the machine can present problems and is always in the responsibility of the operator.

- ▶ The manufacturer will not be held liable for damage or accidents caused by towing.

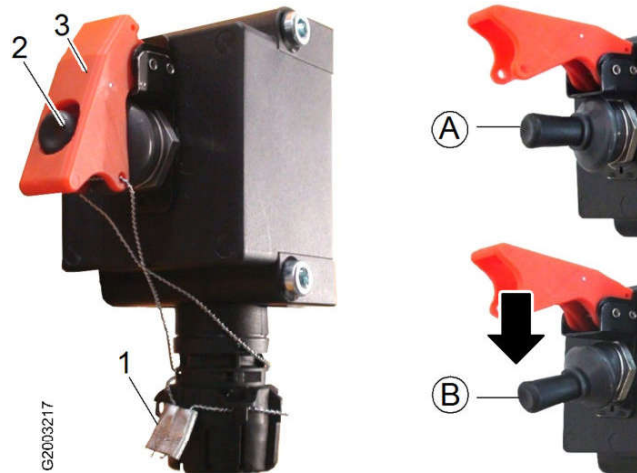

Fig. 513: Activating the towing function

- | | | | |
|---|--|---|---------------------------------|
| 1 | Seal | A | Travel mode active position |
| 2 | Parking brake emergency actuation switch | B | Travel mode not active position |
| 3 | Protective flap | | |

- ▶ Check that the tow bar is properly attached to the towing machine and the wheel loader.

When the tow bar is correctly attached to both vehicles:

- ▶ Remove the seal 1.
- ▶ Open the protective flap 3.
- ▶ Push the switch 2 down (position) B.



- ▷ The parking brake is released.
- ▷ Acoustic warning signal in the operator's cab (continuous tone).
- ▷ The diesel engine is switched off.
- ▷ *Parking brake malfunction* symbol and service code are shown on the display.
- ▷ Emergency steering is activated.
- ▷ Limited service brake functionality.

Towing the machine

- ▶ Remove the chocks.
- ▶ Tow the machine out of the danger area using the tow bar.
- ▶ After finishing towing, use chocks to secure the machine against accidentally rolling away.

4.3 Problem remedy

4.3.1 Replacing fuses

NOTICE

Incorrect fuse rating!
Damage.

- ▶ Use a fuse of the correct rating.
-

Make sure that following requirements are met:

- The affected circuit has been checked.
 - The battery main switch of the machine is turned off.
-

NOTICE

Live components!
Risk of injury.

- ▶ Turn off the battery main switch.
-

There are three fuse boards on the machine:

- Fuse board A4 in the operator's cab
- Fuse board A4a in the left ballast weight
- Fuse board A4b in the operator's cab

Fuses on fuse board A4 in the operator's cab

The board with the plug-in fuses is beside the operator's seat.

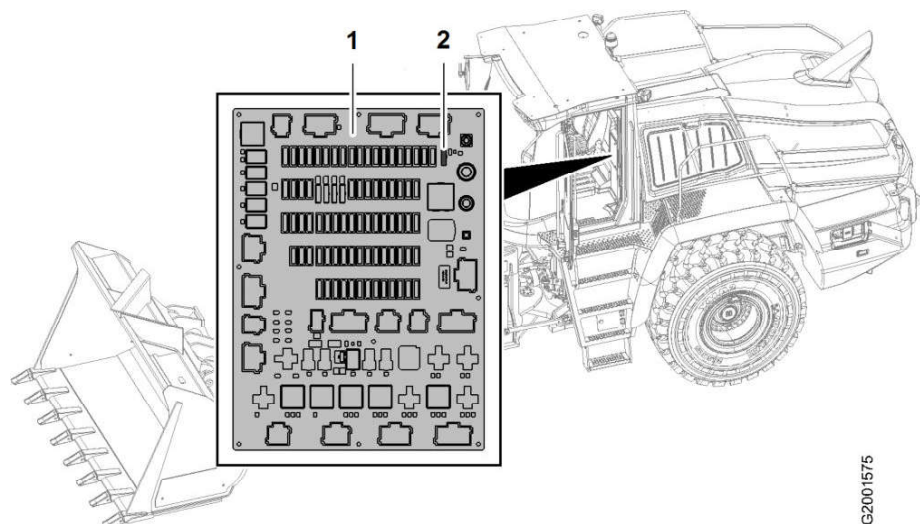

Fig. 544: Fuses on fuse board A4 in the operator's cab

1 Fuse board A4

2 FUSE-TEST

If fuses have to be replaced:

- ▶ Switch off ignition.

5 Maintenance

5.1 Maintenance and inspection schedule

General information

Shorten maintenance intervals depending on conditions of use, for example:

- Dust-intensive use
- Oil quality
- Fuel quality

Ensure that lubricants, liquids and replaced parts are disposed of safely and in an environmentally friendly manner. Comply with applicable country-specific guidelines and applicable laws in country of use.

Service packs in spare parts catalogue contain spare parts required for maintenance activities.

The following abbreviations are used in this section:

- h = operating hours

Various symbols (solid or empty circles, boxes and stars) are used to indicate the maintenance tasks, which fall into two main types.

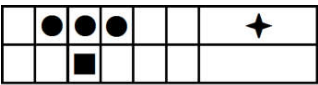
 <p style="text-align: right; margin-right: 50px;">G2010460</p>	<p>The symbols have the following meanings:</p> <p>Table with solid circle, box or star</p> <p>Responsibility for carrying out the maintenance work lies with the machine operator or his maintenance staff. Maintenance interval: every 10, 50 and 500 service hours (h), and at unscheduled times.</p>
--	---

Tab. 86: Machine operator

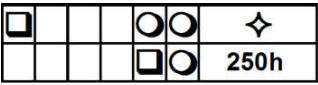
 <p style="text-align: right; margin-right: 50px;">G2010467</p>	<p>The symbols have the following meanings:</p> <p>Table with empty circle, box or star, or service hours (h)</p> <p>The maintenance and inspection work must be performed or supervised by authorised engineers from Liebherr or its authorised dealers. Maintenance interval: on delivery and every 1000, 2000, 3000 service hours (h), and at unscheduled times.</p>
--	--

Tab. 87: Authorised specialist staff

You will find a list of the spare parts needed for maintenance and inspection work in the service package of the spare parts list.

LBH/12239307/07/2020-02-03/en

5.3 Lubricants and fuels

5.3.1 General information on lubricants and fuels

General questions

For general questions on lubricants and fuels, please contact the Liebherr Lubricant Hotline by e-mail.

Liebherr Lubricant Hotline (e-mail): lubricants@liebherr.com

Safety data sheets

Safety data sheets for lubricants and fuels are available online via the Liebherr lubricant portal.

Liebherr lubricant portal: lubricants.liebherr.com

Technical data sheets and specific Liebherr standards

For technical data sheets and specific Liebherr standards: contact Liebherr customer service.

5.3.2 General information on changing lubricants and fuels

The values stated for filling quantities in the lubricant table and fuels table are only guidelines. After every oil change or refill, check the corresponding level.

NOTICE

Improper change of lubricants and fuels!
Damage to machine.

- ▶ Observe manufacturer's instructions for lubricants and fuels.
-

NOTICE

Contamination due to dirt!
Damage to machine.

- ▶ Clean filler plugs, filler caps and drain plugs, including their environment, before opening.
-

When inspecting and changing lubricants and fuels, consider following, among other things:

- Local environmental guidelines.
- Specifications according to operator's manual.
- Avoid naked lights and fire.

5.3.3 Converting hydraulic system from mineral oils to biodegradable hydraulic fluids

For operation of Liebherr earth moving machines with biodegradable hydraulic fluids, we recommend **Liebherr Hydraulic Plus**.

5.5 Preparatory tasks for maintenance

Before performing the various maintenance tasks, move the machine to the maintenance position unless otherwise explicitly specified in the description.

The various maintenance tasks include:

- Lubricating the lift arms and attachment
- Checking the oil level in the engine, transmission, axles, hydraulic tank, etc.
- Changing filters

5.5.1 Maintenance positions

The maintenance position depends on the maintenance task to be performed.

The two basic maintenance positions 1 and 2 are described below.

They enable you to access the individual maintenance points.

Maintenance position 1

To move the machine into maintenance position 1, carry out the following steps.

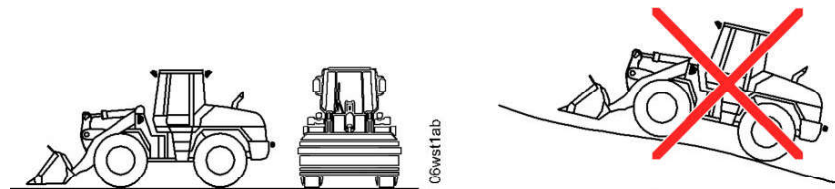

Fig. 553: Maintenance position 1

- ▶ Park the machine on level ground.
- ▶ Lower the lift arms.
- ▶ Lay the bucket flat on the ground.
- ▶ Engage the parking brake.
- ▶ Turn off the engine.
- ▶ Take out the ignition key.
- ▶ Turn off the battery main switch.

Maintenance position 2

To move the machine into maintenance position 2, carry out the following steps.

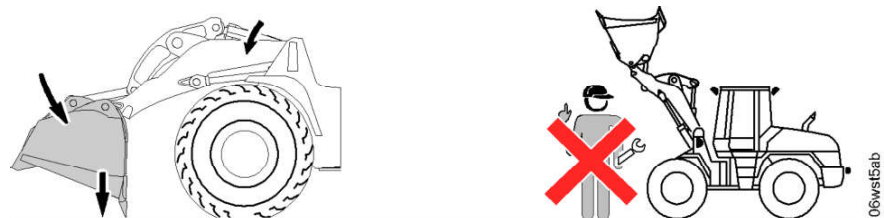

Fig. 554: Maintenance position 2

If the condition deteriorates:

- ▶ Have the hydraulic lines replaced by Liebherr customer service.

Medium damage to the hydraulic lines

Cracks or cuts up to the steel fabric or steel fabric exposed due to damage to the outer jacket

The damage to the outer jacket (such as cracks, cuts or abrasions) through which the steel fabric is exposed is classified as medium damage if the steel fabric is undamaged. Damage to the steel fabric is classified as severe damage.

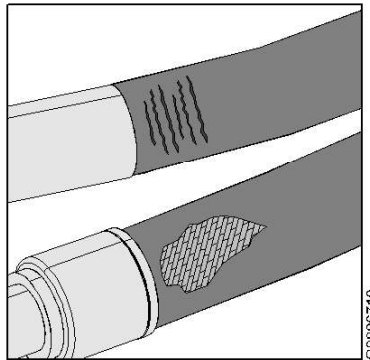

Fig. 564: Cracks or cuts up to the steel fabric or steel fabric exposed due to damage to the outer jacket

- ▶ Document the damage and observe whether the condition deteriorates.

If the condition deteriorates:

- ▶ Have the hydraulic lines replaced immediately by Liebherr customer service.

If the condition does not deteriorate:

- ▶ Have the hydraulic line replaced within the next 250 operating hours by Liebherr customer service.

Moist surfaces, slight oil leak visible

Moist spots can be seen on the surface. Slight oil leak or small oil drops are visible. As long as you do not observe a severe oil leak, it is classified as medium damage.

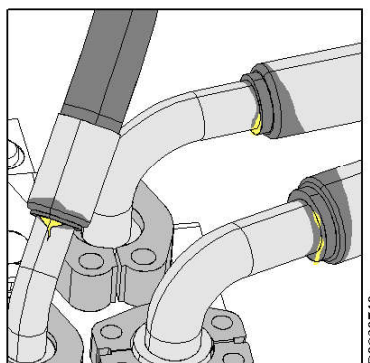

Fig. 565: Moist surfaces, slight oil leak visible

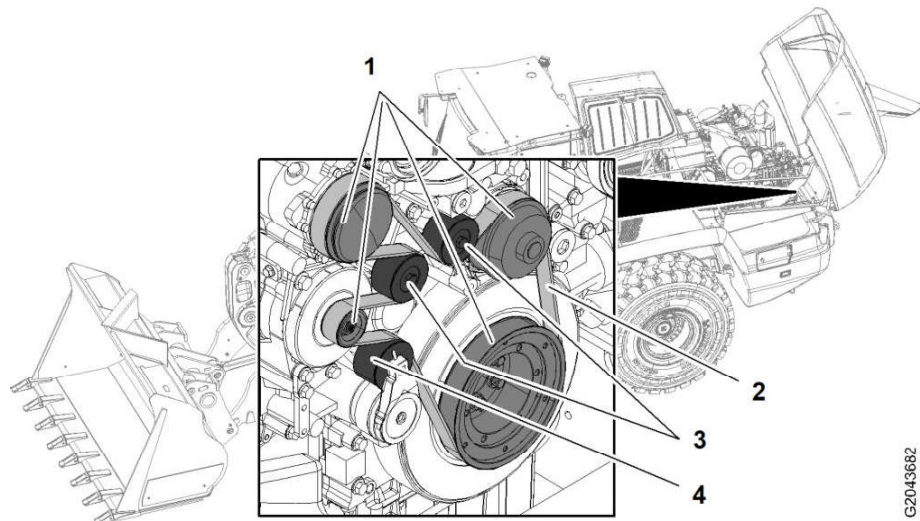

Fig. 573: Checking diesel engine belt drive

- | | |
|-----------------|---------------------|
| 1 Pulleys | 3 Deflector roller |
| 2 V-ribbed-belt | 4 Tensioning device |

Following damage could occur on the V-ribbed belt:

- Broken ribs
- Lumps of rubber on the belt
- Accumulated dirt or grit
- Ribs coming loose from the belt
- Cracks across the back
- Cracks across several ribs

- ▶ Check V-ribbed belt **2** for damage.
- ▶ Check that belt pulleys **1**, deflection rollers **3** and tension device **4** are in good order.

If you find any damage:

- ▶ Have damaged components replaced by Liebherr customer service.

5.7.3 Fuel tank: Draining off condensate and sediment

Make sure that the following requirements are fulfilled:

- The machine is in maintenance position 1.
- You have a suitable receptacle ready.
- The machine has been out of operation for at least 3 hours.



WARNING

Highly flammable consumables!
Beware of burns.

- ▶ Avoid naked lights and fire.

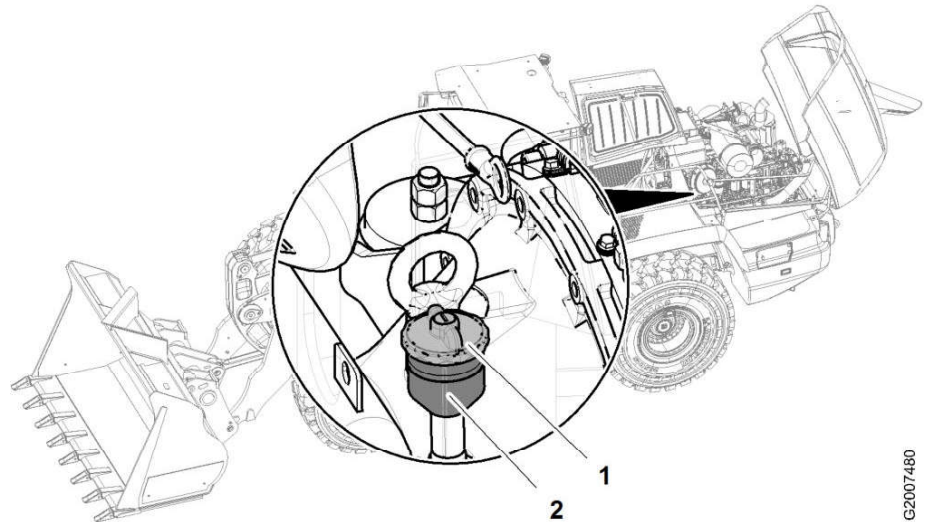

Fig. 584: Checking the oil level

1 Cap

2 Filling tube

- ▶ Take the cap 1 off the filler pipe 2.

NOTICE

Non-approved oil!
Damage.

- ▶ Only use oil that meets the Liebherr specifications.

- ▶ Top up the appropriate amount of splitter box oil via the filler pipe. (For more information see: [5.3.10 Splitter box oil, page 307](#))

- ▶ Clean the cap 1, place it on the filler pipe 2 and tighten it.

5.7.9 Checking that the diesel engine intake and exhaust system is in good condition and not loose or leaking

Make sure that following requirements are met:

- Machine is in maintenance position 1.
- Service access is open.
- Diesel engine has cooled down.

Checking the corrosion inhibitor concentration

In exceptional circumstances, the machine can be filled with corrosion inhibitor without antifreeze.



Note

Corrosion inhibitor without antifreeze may only be used in exceptional cases.

- ▶ Only use corrosion inhibitor without antifreeze when no approved antifreeze and corrosion inhibitor is available and the ambient temperature is above freezing all year round.
- ▶ If in doubt, contact the technical customer service department.

Make sure the following preconditions are met:

- Machine is cold.
- Machine is in maintenance position 1.
- Service access is open.

Make sure that following tools are ready:

- Refractometer with Brix scale
- Drain hose
- Receptacle

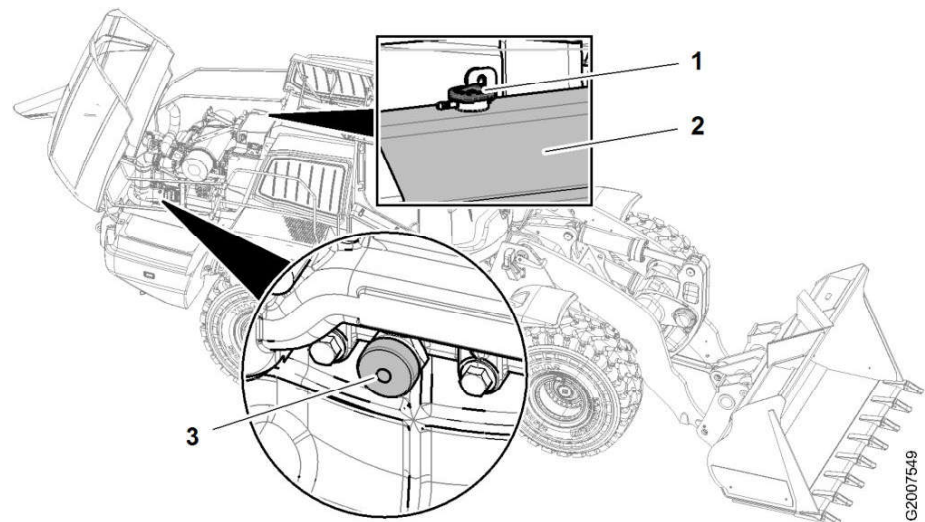

Fig. 592: Checking the corrosion inhibitor concentration

- | | | | |
|---|----------------------|---|-------------|
| 1 | Cap | 3 | Drain valve |
| 2 | Equalising reservoir | | |



CAUTION

Hot, pressurised liquid!
Beware of burns.

- ▶ Let the engine cool down.

- ▶ Open the cap 1 of the equalising reservoir 2.

Checking the corrosion inhibitor concentration

5.12 Electrical system

5.12.1 Checking function of the lighting and horn

Make sure that the following requirements are fulfilled:

- The machine is parked in a safe place.
- The electrical system of the machine is switched on.

All the lights can be tested without starting the machine. Start the machine when testing the reversing headlights.



WARNING

The working headlights can become hot!
Burns, fire.

- ▶ Observe the minimum interval of 1 m (3' 3" ft-in) to persons and material.

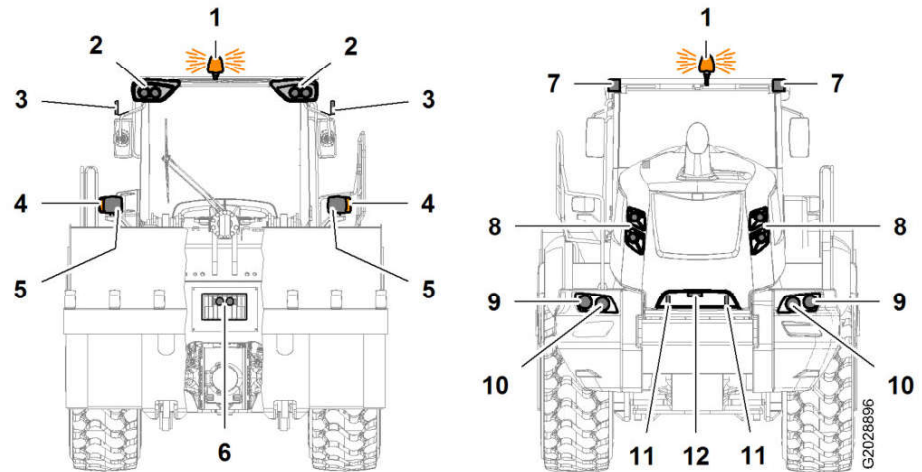

Fig. 601: Lighting

- | | | | |
|---|--|----|---|
| 1 | Flashing beacon (optional) | 7 | Rear working headlight (optional) |
| 2 | Front working headlights | 8 | Engine bonnet working headlight |
| 3 | Marker light (optional) | 9 | Brake light, tail light, rear indicator |
| 4 | Front indicator light | 10 | Reversing light |
| 5 | Driving headlights | 11 | Flash (optional) |
| 6 | Front section working headlight (optional) | 12 | License plate light (optional) |

- ▶ Turn on all the lights.
- ▶ Check all the lights work properly.

When you are checking the brake light:

- ▶ Press the inching brake pedal.

To check the reversing light:

- ▶ Start the machine.
- ▶ Release the parking brake.
- ▶ Select reverse travel direction.
- ▶ Test the reversing light.

Cleaning the recirculated air filter

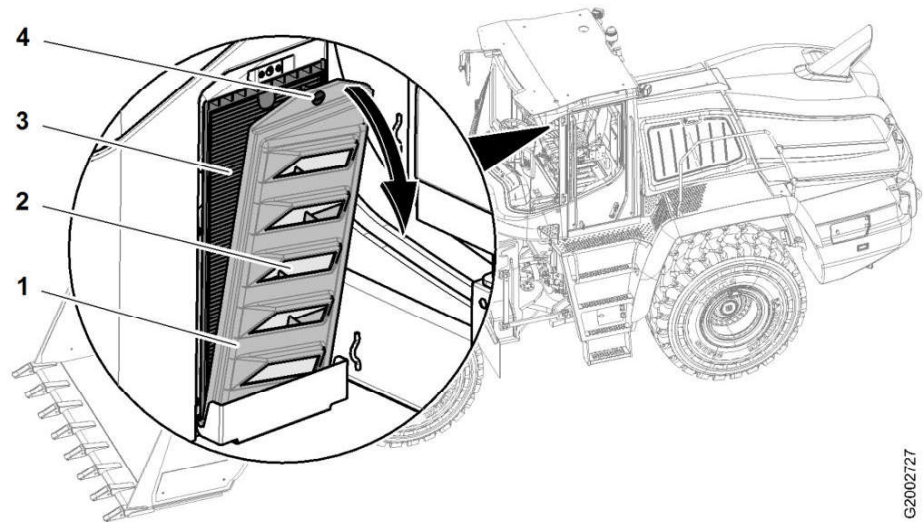

G2002727

Fig. 621: Cleaning the recirculated air filter

- | | | | |
|---|------------------|---|-------------------------|
| 1 | Filter cartridge | 3 | Recirculated air filter |
| 2 | Pre-filter | 4 | Knurled screw |

- ▶ Unscrew the knurled screw **4**.
 - ▷ The filter cartridge **1** is unlocked.
- ▶ Move the filter cartridge **1** forward and take it out.
- ▶ Take the pre-filter **2** out of the filter cartridge **1** and clean it (by blowing it out or washing it).
- ▶ Take out the recirculated air filter **3** and clean it (blow it out).
- ▶ Put in the clean recirculated air filter **3**.
- ▶ Put the pre-filter **2** into the filter cartridge **1** and fit them.
- ▶ Screw in the knurled screw **4**.
 - ▷ The filter cartridge **1** is locked.

5.17.2 Operator's cab: changing fresh air filter and recirculated air filters

Make sure the following preconditions are met:

- Machine is in maintenance position 1.
- The right cab access is extended.
- Suitable protective equipment is used.

CLICK HERE TO **DOWNLOAD** THE COMPLETE MANUAL

- Thank you very much for reading the preview of the manual.
- You can download the complete manual from: www.heydownloads.com by clicking the link below



- Please note: If there is no response to CLICKING the link, please download this PDF first and then click on it.

CLICK HERE TO **DOWNLOAD** THE COMPLETE MANUAL