

**en**

**Operator's manual**

Wheeled excavator

**Document ID**

	ORIGINAL OPERATOR'S MANUAL
<b>Order number:</b>	12211187
<b>Issued:</b>	2020-04-22
<b>Version:</b>	01
<b>Author:</b>	LHB / Technical Documentation Department

**Product ID**

<b>Manufacturer:</b>	Liebherr-Hydraulikbagger GmbH
<b>Type:</b>	A 910 Compact Litronic
<b>Type no.:</b>	1505
<b>From Serial no.:</b>	87687

**Contact**

Liebherr-Hydraulikbagger GmbH  
Liebherrstraße 12  
D – 88457 Kirchdorf/Iller

CLICK HERE TO **DOWNLOAD** THE COMPLETE MANUAL

- Thank you very much for reading the preview of the manual.
- You can download the complete manual from: [www.heydownloads.com](http://www.heydownloads.com) by clicking the link below



- Please note: If there is no response to CLICKING the link, please download this PDF first and then click on it.

CLICK HERE TO **DOWNLOAD** THE COMPLETE MANUAL

3.1.2	Control unit A	58
3.1.3	Control unit B	59
3.1.4	Control unit C	59
3.1.5	Further control units	60
3.1.6	Symbols on control description sticker	60
3.2	Display	68
3.2.1	Display	68
3.2.2	Status symbols	69
3.2.3	Start page menu	82
3.2.4	Camera menu	83
3.2.5	Automatic heating and automatic ventilation	84
3.2.6	Automatic air conditioning	88
3.2.7	Operating status menu	91
3.2.8	Exhaust system submenu	92
3.2.9	Sensor-controlled low idle automatic and automatic engine stop submenu (option)	93
3.2.10	System settings menu	94
3.2.11	Operating hour meter and odometer submenu	95
3.2.12	Windscreen wiper interval submenu	95
3.2.13	Radio remote control submenu	96
3.2.14	Display settings submenu	97
3.2.15	Display brightness and display volume submenu	97
3.2.16	Camera image contrast submenu	98
3.2.17	Camera return time submenu	98
3.2.18	Regional settings and system parameters submenu	99
3.2.19	Unit selection submenu	99
3.2.20	System diagnosis submenu	100
3.2.21	Time zone submenu	100
3.2.22	Time format and date format submenu	101
3.2.23	Language selection submenu	101
3.2.24	Electrical outputs submenu	102
3.2.25	Electrical inputs submenu	103
3.2.26	Function settings menu	103
3.2.27	Central lubrication system submenu (option)	105
3.2.28	Maintenance submenu	105

## 1.2 Technical data

### 1.2.1 Vibration emission

Designation	Unit	Value
Hand/arm vibrations	m/s <sup>2</sup>	≤ 2.5
Whole-body vibrations	m/s <sup>2</sup>	≤ 0.5

Tab. 1: Vibration emission

#### Operator's seat

- The operator's seat built into this machine by the manufacturer conforms to ISO 7096:2000, EM 6.

#### Hand/arm vibrations

- If the machine is operated as intended, the weighted (frequency-weighted) effective value of the hand/arm vibrations in accordance with ISO 5349- 1:2001 is less than 2.5 m/s<sup>2</sup>.

#### Whole-body vibrations

- This value conforms to the details of technical report ISO/TR 25398:2006.
- The measuring inaccuracy is defined in standard EN 12096:1997.
- As the specified values are individual effective values for specific typical application areas, only a limited assessment of the load imposed on the operator by whole-body vibrations is possible.

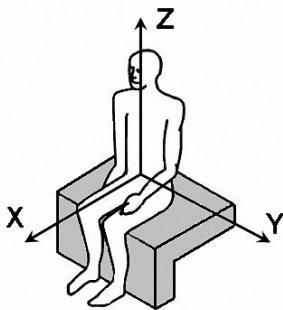

### 1.2.2 CO<sub>2</sub> emissions of diesel engine

#### NOTICE

Incorrect operation!  
High emission values.

- ▶ Operate and service diesel engine and exhaust treatment system according to operator's manual.

	mm
A	2,525
B	2,550
B1	2,550
B2	2,550
B3	2,550
C	3,150
D	1,675
E	1,675
H	2,575
I1	405
I2	420
I3	465
I5	420
J1	585
J2	625
J3	650
J5	625
K	1,210
L	2,400
M	1,100
M1	1,300
Q	340
T1	1,185
T2	1,105
T3	1,170
T5	1,120
U2	4,235
U5	4,710
U7	4,690

E = Tail radius  
Tyres 9.00-20

Stick	Two-piece boom 4.00 m				
	Rear blade	Rear outriggers	Rear outriggers + front blade	Rear two-piece blade	Rear two-piece + front blade
	m	mm	mm	mm	mm
V	1.85	6,250	6,350	6,350	6,300
W	1.85	2,400	2,400	2,400	2,400
X	1.85	8,100	8,200	8,200	8,150

Dimensions are with equipment over steering axle  
W = Max. ground clearance including approx. 150 mm piping

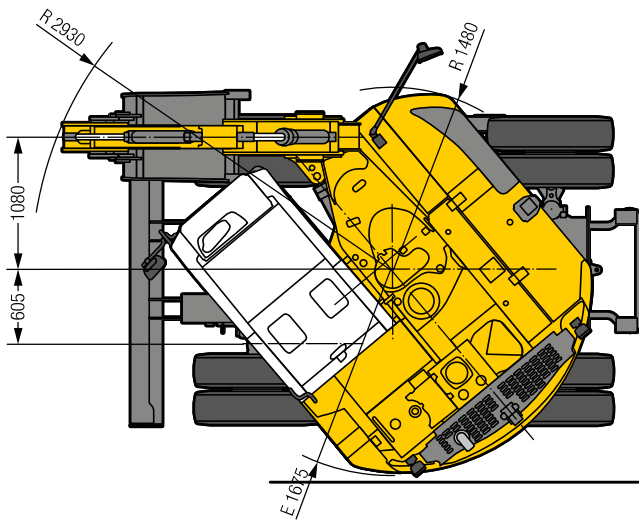

**Min. turning radius on tyres 9.00-20**

Four wheel steering 4.17 m

Front wheel steering 6.29 m

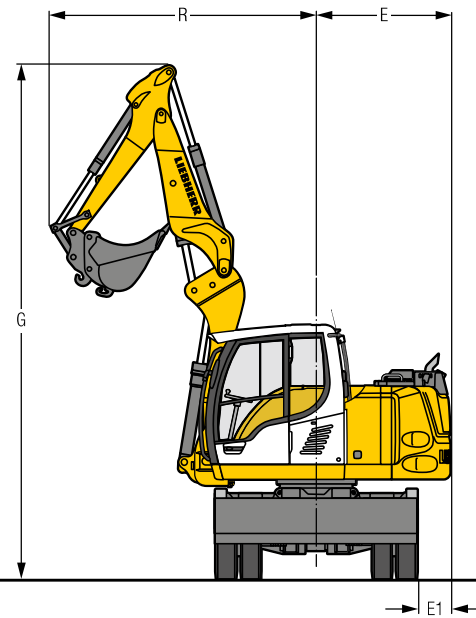

Boom	Stick m	G mm	R mm	E mm	E1 mm
Two-piece boom	1.85	6,380	3,320	1,675	405



## Operator's Cab

<b>Cab</b>	ROPS safety cab structure (roll-over protection system) with individual windscreens or featuring a slide-in subpart under the ceiling, work headlights integrated in the ceiling, a door with a sliding window (can be opened on both sides), large stowing and depositing possibilities, shock-absorbing suspension, sounddamping insulating, tinted laminated safety glass, separate window shades for the sunroof window and windscreen
<b>Operator's seat Standard</b>	air cushioned operator's seat with 3D-adjustable armrests, headrest, lap belt, seat heater, manual weight adjustment, adjustable seat cushion inclination and length and mechanical lumbar vertebrae support
<b>Operator's seat Comfort (Option)</b>	in addition to operator's seat standard: lockable horizontal suspension, automatic weight adjustment, adjustable suspension stiffness, pneumatic lumbar vertebrae support and passive seat climatisation with active coal
<b>Operator's seat Premium (Option)</b>	in addition to operator's seat comfort: active electronic weight adjustment (automatic re-adjustment), pneumatic low frequency suspension and active seat climatisation with active coal and ventilator
<b>Control system</b>	joysticks with arm consoles and swivel seat, folding left arm console
<b>Operation and displays</b>	large high-resolution operating unit, self-explanatory, colour display with touchscreen, video-compatible, numerous setting, control and monitoring options, e.g. air conditioning control, fuel consumption, machine and tool parameters
<b>Air-conditioning</b>	automatic air-conditioning including demisting (optional). Automatic heating and ventilation system (standard): fast de-icing at the press of a button, air vents can be operated via a menu; recirculated air and fresh air filters can be easily replaced and are accessible from the outside; designed for extreme outside temperatures, sensors for solar radiation, inside and outside temperatures



## Undercarriage

<b>Drive</b>	oversized two speed power shift transmission with additional creeper speed, Liebherr axial piston motor with functional brake valve on both sides
<b>Pulling force</b>	84 kN
<b>Travel speed</b>	0 – 3.5 km/h stepless (creeper speed off-road) 0 – 7.0 km/h stepless (off-road) 0 – 13.0 km/h stepless (creeper speed on-road) 0 – 20.0 km/h stepless (road travel) 0 – max. 25.0 or 30.0 km/h Speeder (Option)
<b>Driving operation</b>	automotive driving using accelerator pedal, cruise control function: storage of variable accelerator pedal positions, both off-road and on-road
<b>Axles</b>	manual or automatic hydraulically controlled front axle oscillation lock
<b>Option</b>	four wheel steering
<b>Service brake</b>	two circuit travel brake system with accumulator; wet and backlash-free disc brake
<b>Holding brake</b>	wet multi-disc (spring applied, pressure released)
<b>Stabilization</b>	stabilizing blade (adjustable during travel for dozing) 2 point outriggers stabilizing blade front + 2 point outriggers rear divided blade rear divided blade rear and stabilizing blade front



## Attachment

<b>Type</b>	high-strength steel plates at highly stressed points for the toughest requirements. Complex and stable mountings of attachment and cylinders
<b>Hydraulic cylinders</b>	Liebherr cylinders with special seal system as well as shock absorption
<b>Bearings</b>	sealed, low maintenance



## Complete Machine

<b>Lubrication</b>	Option	Liebherr central lubrication system for upper-carriage and attachment, automatically
<b>Noise emission</b>	ISO 6396	$L_{pA}$ (inside cab) = 71 dB(A)
	2000/14/EC	$L_{WA}$ (surround noise) = 99 dB(A)

## Environmental pollution

### Unapproved disposal of machine

- Make sure that the individual elements of the machine are disposed of correctly after the service life.
- Dispose of elements of machine in line with valid country-specific waste disposal guidelines and relevant valid laws.
- Remove fuels, operating fluids and lubricants from all components before disposal.
- Collect and store fuels, operating fluids and lubricants in suitable containers before disposal.
- Adhere to instructions of relevant manufacturer when disposing of fuels, operating fluids and lubricants.
- Have fuels, operating fluids and lubricants disposed of by old oil recycling point.
- Have metal parts disposed of by metal recycling point.
- Have plastic parts disposed of by plastic recycling point.
- Have rubber parts disposed of by rubber recycling point.
- Have electronic components disposed of by electronics recycling point.

## 2.3 Description of staff

### 2.3.1 Personal protective equipment

Operators, assistants and maintenance staff are responsible for the following:

- Wearing personal protective equipment
- Regular cleaning and care of protective equipment
- Immediate replacement of damaged parts of protective equipment



The protective equipment consists of following elements:

- Protective helmet
- Safety glasses
- Hearing protection
- Breathing equipment
- Protective gloves
- Warning clothing (reflective, in signal colour)
- Safety boots
- Special protective clothing
  - To prevent burns
  - To prevent freezing
  - To prevent acid burns
  - To prevent stabbing and cutting injuries

### 2.3.2 Requirements for staff

Staff meet the following requirements:

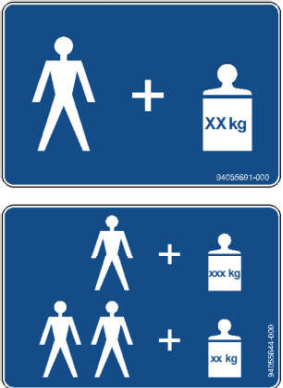
- The machine is operated, maintained and repaired exclusively by authorised and trained persons.
- All persons operating, maintaining or repairing the machine have the required minimum age.
- Staff training involves theoretical information (technology and safety) and practical training on the machine.

Sign	Description
	<p><b>Jump starting</b> Applies to machines with diesel engine. Before jump-starting machine, read instructions in the operator's manual.</p>
	<p><b>Load capacity</b> Indicate maximum load capacity value of height adjustable cab.</p>
	<p><b>Closing upper windscreen</b> Applies to wheeled excavators. Indicates sequence for closing upper windscreen.</p>
	<p><b>Speed 20 km/h</b> Applies to wheeled excavators. Indicates maximum permitted speed.</p>

Tab. 8: Warning signs

## 2.4.2 Information signs

These signs contain information about:

- Machine operation
- Machine maintenance
- Machine characteristics

- Keep your face towards machine during entry and exit.
- Make sure you always have two hands and a foot or two feet and one hand in contact with the access system.
- After entering the operator's cab, find out about emergency exit.

If the machine has a cab elevation:

- Climb until the door is reached.
- When you reach door handle with your free hand: Open door.
- Continue climbing.

Adhere to safety instructions on entry and exit in operator's manual of complete machine:

- If the uppercarriage is mounted on a support.
- If the machine is part of a system.
- If the uppercarriage is mounted on a pontoon or rail guide system.

## 2.7.5 Machine danger zone

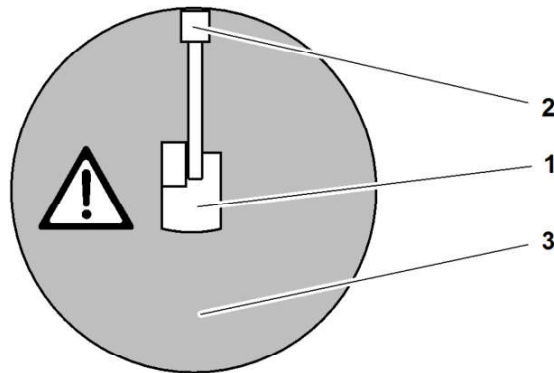

Fig. 55: Machine danger zone (view from above)

- |   |                             |   |             |
|---|-----------------------------|---|-------------|
| 1 | Machine                     | 3 | Danger zone |
| 2 | Reach of working attachment |   |             |

### Danger to life

#### Unapproved presence in danger zone

- Make sure there are no persons in danger zone.

## 2.7.6 Visibility

### Danger to life

#### Insufficient visibility

- Make sure that persons approach machine from the front and within operator's field of vision.
- Make sure that persons contact the operator before approaching the machine.
- Make sure that no obstacles impair visibility in the working area.
- Use viewing devices to observe environment of machine if necessary.
- Use viewing devices if necessary to observe areas around the machine that cannot be seen directly.

- 10 Magnet system key (option)
- 11 Quick coupler key (option)

- 21 Beacon key (option)
- 22 Travel light key

### 3.1.3 Control unit B

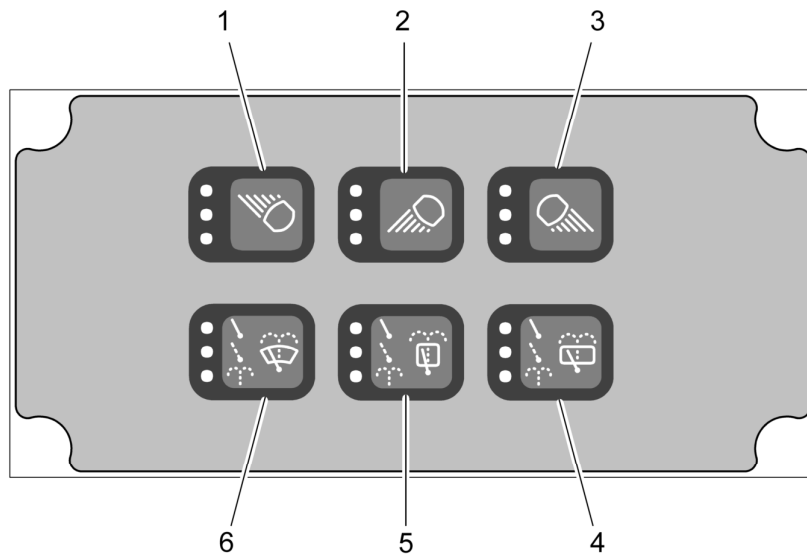

Fig. 58: Control unit B

- 1 Working attachment headlight key
- 2 Front operator's cab headlight key
- 3 Rear operator's cab headlight key
- 4 No function assigned
- 5 Roof glass panel key (option)
- 6 Windscreen key

### 3.1.4 Control unit C

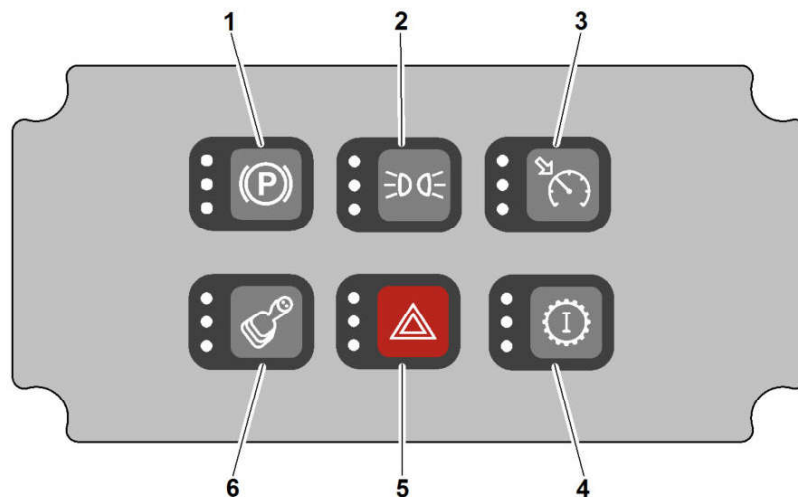

Fig. 59: Control unit C

- 1 Parking brake key
- 2 Parking light key
- 3 Speed controller key
- 4 Gear key
- 5 Hazard warning lights key
- 6 Servo control key

LHB/12211187/01/2020-04-22/en

## Selecting menu via menu bar

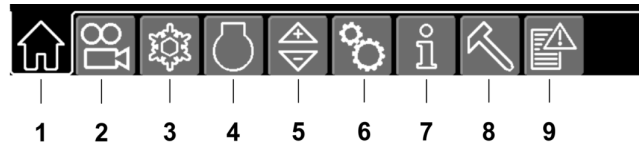

Fig. 214: Menu bar

- |   |  |   |                               |
|---|--|---|-------------------------------|
| 1 | Start page menu button   | 6 | Function settings menu button |
| 2 | Camera menu button <sup>1)</sup>   | 7 | Information menu button       |
| 3 | Automatic heating, automatic ventilation and automatic air conditioning system menu button | 8 | Tool Control menu button      |
| 4 | Operating status menu button   | 9 | Service codes menu button     |
| 5 | System settings menu button  |   |                               |

- ▶ Press menu button in menu bar.
  - ▷ Symbol of selected menu has a black background.

## Selecting menu via programmable keys

### Programming key

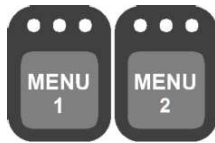

- ▶ Select menu: Press menu button in menu bar.
- ▶ Press *MENU 1* key or *MENU 2* key until middle and right LEDs light up.
- ▶ Release key/button.
  - ▷ Left LED lights up.
  - ▷ Menu is saved to key.

### Selecting menu via key

- ▶ Press *MENU 1* key or *MENU 2* key.
  - ▷ Menu appears on the display.



## 3.2.2 Status symbols

The symbols in the status bar indicate the operating status. The displayed symbols depend on model and equipment of machine.

### General symbols







Symbol	Meaning
	Confirmation required; press confirmation button.
	Confirmation error; press confirmation button.

<sup>1)</sup> not valid for Rail machines.

Symbol	Meaning
	Diesel engine emergency mode active
	Preglowing



Tab. 26: Status symbols of diesel engine

## Oscillating axle

Symbol	Meaning
	Oscillating axle support automatic; oscillating axle unlocked
	Oscillating axle support automatic; oscillating axle locked
	Oscillating axle locked
	Oscillating axle locked
	Oscillating axle locked
	Backward Stability locks oscillating axle.

Tab. 27: Status symbols of oscillating axle

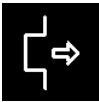
## Quick coupler

Symbol	Meaning
	Quick coupler active
	Quick coupler 2 active

## Operation via menu

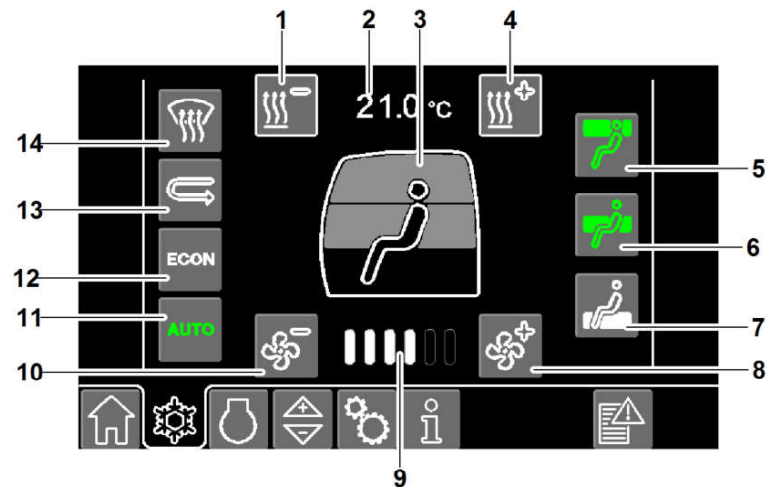

Fig. 388: Air conditioning menu

- |   |                                 |    |                                    |
|---|---------------------------------|----|------------------------------------|
| 1 | Reducing temperature button     | 8  | Increasing blower power button     |
| 2 | Set temperature                 | 9  | Bar chart display for blower power |
| 3 | Operating status of air outlets | 10 | Reducing blower power button       |
| 4 | Increasing temperature button   | 11 | Automatic mode button              |
| 5 | Head area air outlets button    | 12 | ECON button                        |
| 6 | Chest area air outlets button   | 13 | Recirculated air button            |
| 7 | Foot area air outlets button    | 14 | Defrosting and defogging button    |

## Automatic mode

The climate in the cab depends on the following factors:

- Set temperature
- Outside temperature
- Direct sunlight

Depending on these factors, the following functions are adjusted automatically:

- Air distribution
- Cooling power
- Heating power
- Blower power

- ▶ Press *automatic mode* button.
  - ▷ *Automatic mode* button lights up green.



## Setting set temperature

- ▶ Press *reducing temperature* or *increasing temperature* button.
  - ▷ Set temperature **2** is displayed in °C.



## Setting blower power







- ▶ Press *reducing blower power* or *increasing blower power* button.
  - ▷ Bar chart display for blower power **9** displays set value.
  - ▷ Automatic setting of blower power is switched off.



If the display is not used, it displays the *camera* menu after the return time has elapsed.

### 3.2.18 *Regional settings and system parameters submenu*







Menu call:  > 

Menu button	Designation
	Time format and date format (For more information see: <a href="#">3.2.22 Time format and date format submenu, page 101</a> )
	Time zone (For more information see: <a href="#">3.2.21 Time zone submenu, page 100</a> )
	Language selection (For more information see: <a href="#">3.2.23 Language selection submenu, page 101</a> )
	Unit selection (For more information see: <a href="#">3.2.19 Unit selection submenu, page 99</a> )
	Electrical inputs (For more information see: <a href="#">3.2.25 Electrical inputs submenu, page 103</a> )
	Electrical outputs (For more information see: <a href="#">3.2.24 Electrical outputs submenu, page 102</a> )
	System diagnosis (For more information see: <a href="#">3.2.20 System diagnosis submenu, page 100</a> )

Tab. 38: Menu buttons

### 3.2.19 *Unit selection submenu*

Menu call:  >  > 

-  *Slewing gear fine adjustment* menu button  
Fine adjustment of rotating speed of uppercarriage
-  *Travel gearbox fine adjustment* menu button<sup>11)</sup>  
Fine adjustment of speed of travel gearbox
-  *Travel gear fine adjustment* menu button<sup>12)</sup>  
Fine adjustment of speed of travel gear
-  *Boom and stick fine adjustment* menu button  
Fine adjustment of speed of boom and stick
-  *Adjustable boom fine adjustment* menu button<sup>13)</sup>  
Fine adjustment of speed of adjustable boom
-  *Laterally adjustable boom fine adjustment* menu button<sup>14)</sup>  
Fine adjustment of speed of laterally adjustable boom
-  *Rotary stick fine adjustment* menu button<sup>15)</sup>  
Fine adjustment of speed of rotary stick

### 3.2.30 User profile submenu

In the *user profile* submenu it is possible to save the fine adjustment of control elements. The most recently saved conditions are restored when a user profile is activated.

Menu call:  >  > 



Fig. 466: User profile submenu and on-screen keyboard submenu

- |                                  |                              |
|----------------------------------|------------------------------|
| 1 On-screen keyboard menu button | 3 User profile button        |
| 2 Factory settings button        | 4 On-screen keyboard submenu |

- ▶ Rename user profile: Press *on-screen keyboard* menu button 1.
  - ▷ *On-screen keyboard* submenu 4 appears.

- 11) Applies to wheeled excavators
- 12) Applies to machines with travel gear
- 13) Applies to machines with adjustable boom
- 14) Applies to machines with laterally adjustable boom
- 15) Applies to machines with rotary stick

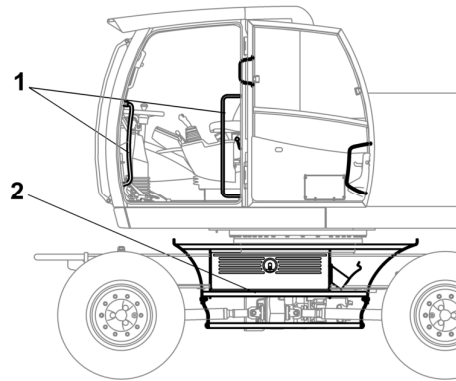

Fig. 490: Climbing facilities

1 Handles

2 Steps

## Entering machine

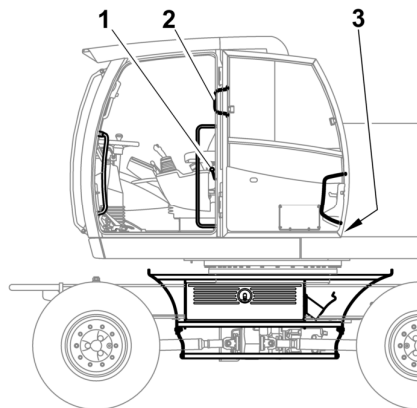

Fig. 491: Entering machine

1 Unlocking mechanism

2 Handle

3 Locking mechanism

- ▶ Open door.
- ▶ Engage door in locking mechanism 3.
- ▶ Enter machine.
- ▶ Unlock door with unlocking mechanism 1.
- ▶ Adjust operator's seat and steering wheel.

If machine is driving on road:

- ▶ Close door with handle 2.

If door is open in working mode:

- ▶ Make sure that door is engaged in locking mechanism 3.

## Exiting machine

- ▶ Move folding console up.

- ▶ Sit on operator's seat.
- ▶ Turn ignition key to I. (For more information see: 3.3.9 Ignition key, page 132)
  - ▷ Operator's seat automatically adjusts to body weight.
  - ▷ Setting is stored for 5 minutes after leaving operator's seat.
- ▶ Ensure that automatic adjustment is completed.
- ▶ If necessary, adjust operator's seat with *Adjust operator's seat* button 1.
- ▶ When operator changes, sit on operator's seat.
  - ▷ Operator's seat automatically adjusts to body weight.
  - ▷ Setting is stored for 5 minutes after leaving operator's seat.

## Adjusting lumbar support

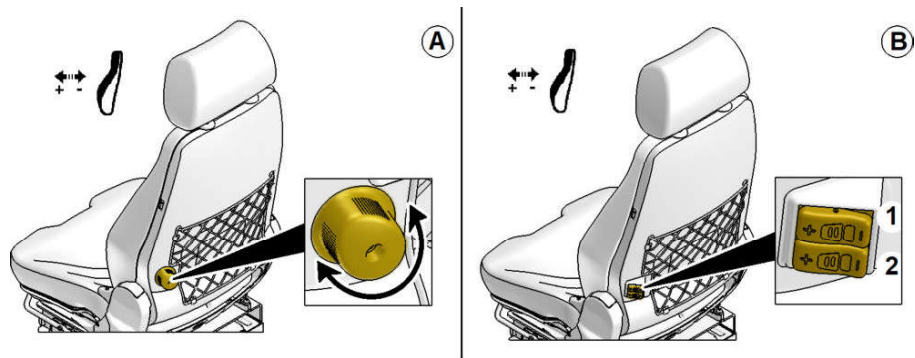

Fig. 511: Adjusting lumbar support

- |   |                                     |   |                           |
|---|-------------------------------------|---|---------------------------|
| A | Manual adjustment                   | 1 | Upper back cushion button |
| B | Pneumatic adjustment <sup>17)</sup> | 2 | Lower back cushion button |

## Switching seat heating on and off (option)

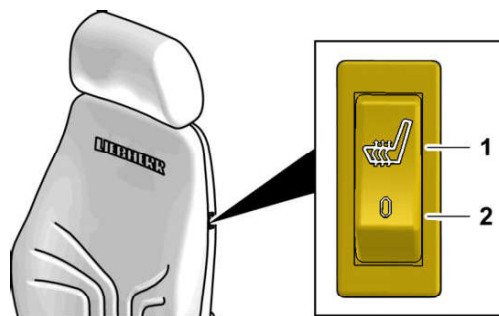

Fig. 512: Seat heating

- |   |                        |   |                         |
|---|------------------------|---|-------------------------|
| 1 | Switch on seat heating | 2 | Switch off seat seating |
|---|------------------------|---|-------------------------|

<sup>17)</sup> Option

- Mirrors and windows are clean.
- Camera images are displayed in real time.
- Cameras and display are clean.

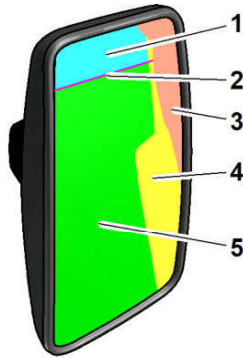

Fig. 538: Field of vision in left side mirror

- |   |             |   |                 |
|---|-------------|---|-----------------|
| 1 | Sky         | 4 | Machine         |
| 2 | Horizon     | 5 | Field of vision |
| 3 | Hidden area |   |                 |

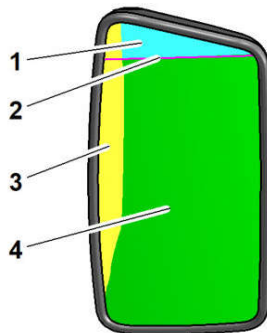

Fig. 539: Field of vision in right side mirror

- |   |         |   |                 |
|---|---------|---|-----------------|
| 1 | Sky     | 3 | Machine         |
| 2 | Horizon | 4 | Field of vision |

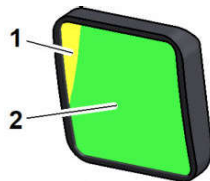

Fig. 540: Field of vision in right wide-angle mirror

- |   |         |   |                 |
|---|---------|---|-----------------|
| 1 | Machine | 2 | Field of vision |
|---|---------|---|-----------------|
- ▶ Adjust mirrors.

LHB/12211187/01/2020-04-22/en

### 3.4.2 Refuelling

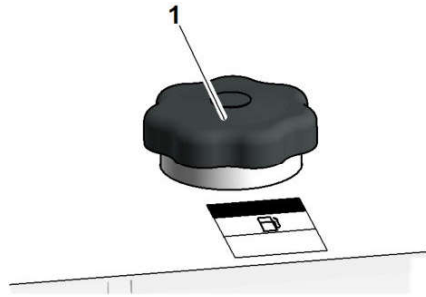

Fig. 577: Fuel tank

1 Tank lid



#### DANGER

Explosion of highly flammable fuel!  
Danger to life.

- ▶ Avoid naked flames.
- ▶ Do not smoke.



#### Note

Sulphur content of fuel affects change interval of engine oil and oil filter.

- ▶ Adhere to sulphur content of fuel and change intervals of engine oil.

If sulphur content of fuel is not known:

- ▶ Determine sulphur content with oil analysis set.

### 3.4.3 Refuelling with electric refuelling pump (option)

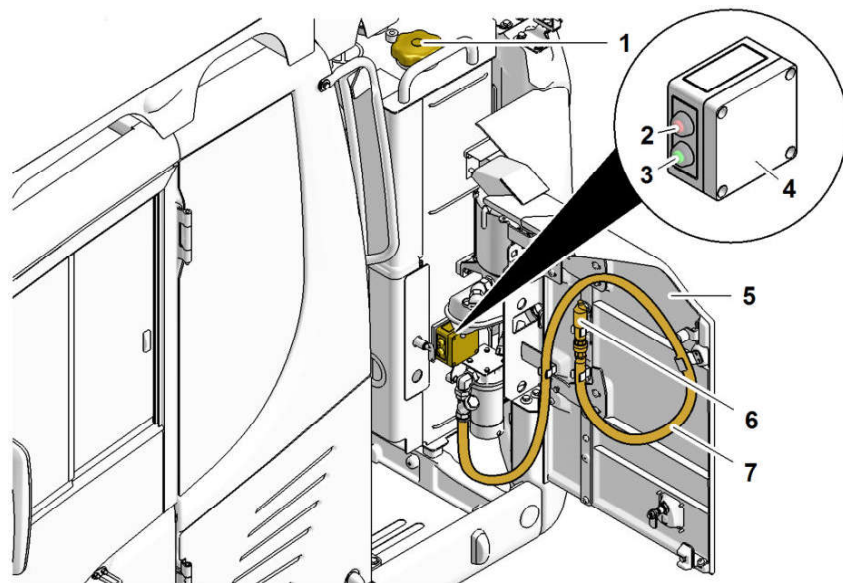

Fig. 578: Electric refuelling pump

1 Tank lid

5 Left side door

*See next page for continuation of the image legend*



CLICK HERE TO **DOWNLOAD** THE COMPLETE MANUAL

- Thank you very much for reading the preview of the manual.
- You can download the complete manual from: [www.heydownloads.com](http://www.heydownloads.com) by clicking the link below



- Please note: If there is no response to CLICKING the link, please download this PDF first and then click on it.

CLICK HERE TO **DOWNLOAD** THE COMPLETE MANUAL

Status symbol	Warning sound	Meaning
	Intermittent warning sound	Automatic engine stop before long.
		Automatic engine stop active. Diesel engine is shut off.
		Automatic engine stop is blocked.

Tab. 52: Status symbols and warning sounds

- ▶ Set shut-off period for automatic engine stop. (For more information see: [3.2.9 Sensor-controlled low idle automatic and automatic engine stop submenu \(option\)](#), page 93)
- ▶ Activate automatic engine stop. (For more information see: [3.2.9 Sensor-controlled low idle automatic and automatic engine stop submenu \(option\)](#), page 93)



- ▷ LEDs in *sensor-controlled low idle automatic* key light up.
- ▷ *Sensor-controlled low idle automatic* key does not function.
- ▶ Start diesel engine after automatic engine stop: Move folding console up.
- ▶ Press *start/stop* key.

### 3.4.14 Shutting off diesel engine



- ▶ Make sure that all control elements are in neutral position.
- ▶ Press *start/stop* key.

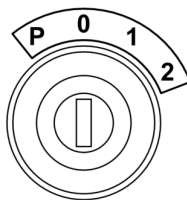

- ▶ Set ignition key to 0.
- ▶ Pull out ignition key.

- ▶ Push *switching off travel alarm* switch,  
or
- Press *deactivating travel alarm* button.
- ▷ Warning sound stops after 10 s.

### 3.4.22 Locking and unlocking oscillating axle



**DANGER**  
Machine tipping over!  
Danger to life.

- ▶ Make sure that operating mode of oscillating axle is set correctly.

#### Setting operating mode

Switch position	Operating mode	Property
	Oscillating axle is unlocked.	Stability is reduced. The oscillating axle adapts to surface roughness.
	Oscillating axle is locked.	Stability is increased. Oscillating axle does not adapt to surface roughness.
	Oscillating axle support automatic	Unlocked: Stability is reduced. The oscillating axle adapts to surface roughness.
		Locked: Stability is increased. Oscillating axle does not adapt to surface roughness.

Tab. 59: Oscillating axle switch switch position

Application	Operating mode
On-road travel	Oscillating axle is unlocked.
Travel at operating location. (For more information see: <a href="#">3.6.3 Travelling at operating location, page 212</a> )	Oscillating axle is unlocked. Oscillating axle support automatic: Oscillating axle is unlocked.
Travel with load at operating location.	Oscillating axle is unlocked. Oscillating axle support automatic: Oscillating axle is unlocked.
Working	Oscillating axle is locked. Oscillating axle support automatic: Oscillating axle is locked.

Tab. 60: Selecting operating mode

- ▶ Release left joystick.
  - ▶ Press *slewing brake* switch **1** to position **A**.
- If two LEDs in *slewing brake* key flash:
- ▶ Wait until LEDs in *slewing brake* key light up.
    - ▷ Uppercarriage is locked.

### Deactivating locking mechanism

#### Deactivating locking mechanism with joystick

- ▶ Move left joystick to left or to right.

#### Deactivating locking mechanism with switch

- ▶ Press *slewing brake* switch **1** to position **A**.
  - ▷ LEDs in *slewing brake* key go out.
  - ▷ Uppercarriage can be turned.

### Locking uppercarriage automatically

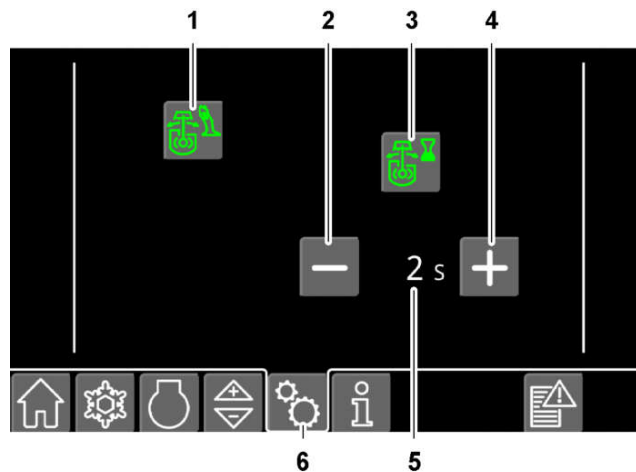

Fig. 675: Comfort slewing brake menu: Automatic mode

- |   |                              |   |                                |
|---|------------------------------|---|--------------------------------|
| 1 | Semi-automatic button        | 4 | Increasing locking time button |
| 2 | Reducing locking time button | 5 | Locking time                   |
| 3 | Automatic button             | 6 | Function settings menu button  |

After the locking time has elapsed the comfort slewing gear locks the stationary uppercarriage.



#### Note

Different machine configuration!





- ▶ Observe control description sticker.

#### Switching on automatic

- ▶ Press *function settings* menu button **6**.



## Switching on reversible fan drive manually

Key	Status of LEDs	Function
		Fan changes from normal mode to stationary.
		Fan turns in opposite direction of rotation.
		Fan changes from opposite direction of rotation to stationary.

Tab. 69: Switching on reversible fan drive manually

- Make sure that air intake area is free from persistent soiling (For more information see: 5.9.2 Checking cooling system and heat exchanger for contamination, page 324) .

## Automatic reversible fan drive (option)

Menu call:  > 

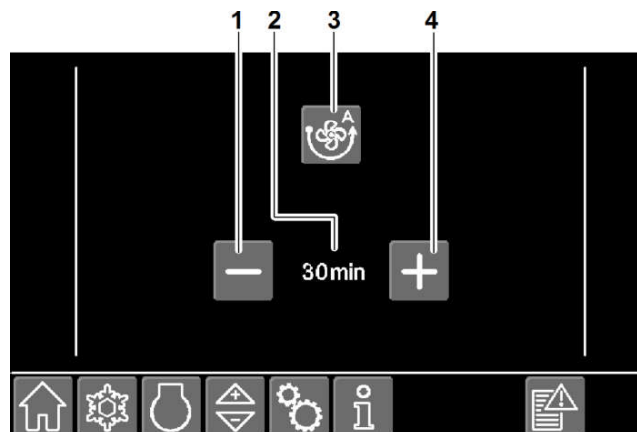



Fig. 707: Automatic reversible fan drive menu

- |                                 |   |
|---------------------------------|---|
| 1 Reducing time interval button | 3 Automatic reversible fan drive button |
| 2 Set time interval             | 4 Increasing time interval button       |

Key	Function
	Automatic reversible fan drive is switched off.

LHB/12211187/01/2020-04-22/en

- ▶ Turn key to right into enabled position for authorisation.
- ▶ Press *height limitation* button.
- ▶ Press confirmation button.
  - ▷ *Height limitation* button lights up white:



- ▶ Turn key to left for authorisation.

## Switching on height limitation

Make sure the following precondition is met:

- Settings for height limitation are enabled.
- ▶ Press *height limitation* button.
- ▶ Press confirmation button.
  - ▷ *Height limitation* button lights up green:



## Switching off height limitation

Make sure the following precondition is met:

- Settings for height limitation are enabled.
- ▶ Press *height limitation* button.
- ▶ Press confirmation button.
  - ▷ *Height limitation* button lights up white:



## Locking settings for height limitation



### Note

After height limitation is locked, switched-on load moment limitation is locked.

- ▶ Make sure that load moment limitation is switched off.



### Note

After height limitation is locked, switched-on slew limitation is locked.

- ▶ Make sure that slew limitation is switched off.



### Note

After height limitation is locked, switched-on virtual wall is locked.

- ▶ Make sure that virtual wall is switched off.

A supervisor is authorised to lock following settings for the operator:

- Switch off height limitation.

**DANGER**

Machine tipping over!  
Danger to life.

If warning sound sounds and *overload warning* status symbol appears on the display:

- ▶ Exclusively perform load-reducing movements.



If warning sound sounds and *overload warning system* status symbol appears on the display:

- ▶ Reduce reach.

## Checking the overload warning system

According to regulations the overload warning system must be checked in following situations:

- After starting the machine
- Before lifting a load

Make sure the following preconditions are met:

- Machine is on level and firm ground.
- Uppercarriage is aligned parallel to undercarriage.
- Oscillating axle is locked.

- ▶ Raise boom to the stop.
- ▶ When the stop is reached, continue to steer boom in lifting direction.
  - ▷ Overload warning system status symbol appears on the display.
  - ▷ Warning sound sounds.

If no warning sound sounds of *overload warning system* status symbol does not appear on the display:

- ▶ Do not perform any load lifting work.
- ▶ Contact Liebherr customer service.

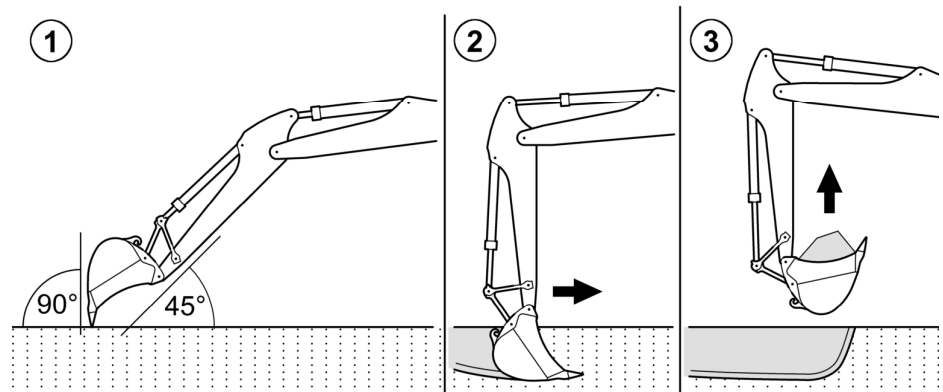

Fig. 791: Working with backhoe bucket

- |   |                                 |   |                          |
|---|---------------------------------|---|--------------------------|
| 1 | Aligning stick and working tool | 3 | Lifting digging material |
| 2 | Picking up digging material     |   |                          |

## Aligning stick and working tool

(see: fig. 791, page 219) – Fig 1

- ▶ Align stick so that underside is at an angle of about 45° to the ground.
- ▶ Align working tool so that piston side penetrates the ground at an angle of about 90°.

## Picking up digging material

(see: fig. 791, page 219) – Fig 2

- ▶ Adhere to load lift chart<sup>19)</sup>.
- ▶ To excavate digging material, swivel stick in slowly and evenly and simultaneously swivel in working tool slowly and evenly.



### CAUTION

Impact loads and vibrations on working tool!  
Damage to working tool.

- ▶ Avoid jerky movements.

When the stick is at right angles to the ground:

- ▶ In addition to swivelling in stick and working tool, also slowly and evenly raise boom.

## Lifting digging material

(see: fig. 791, page 219) – Fig 3

When the working tool is full or the stick is fully swivelled in:

- ▶ Raise boom and swivel in working tool until filling surface is parallel with the ground.

<sup>19)</sup> The load lift chart states the permissible loads that can be lifted at the end of the stick, depending on the reach.

## 3.9 Transport

### 3.9.1 Preparatory work

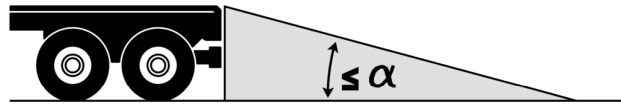

Fig. 798: Loading ramp

Make sure the following preconditions are met:

- Loading ramp is designed for required load capacity.
- Inclination angle  $\alpha$  of loading ramp is smaller than  $15^\circ$ .
- Loading ramp is clean, free from snow and free from ice.
- Loading surface of low-loader is clean, free from snow and free from ice.

▶ Push blocks under loading ramp.

If wheeled excavator is being loaded:

▶ Make sure that tyres are clean, free from snow and free from ice.

If crawler excavator is being loaded:

▶ Make sure that travel gear is clean, free from snow and free from ice.

▶ Place non-slip mats as per EN 12195-1 on loading surface of low-loader.

### 3.9.2 Driving machine onto low-loader



#### Note

Different machine configuration!

▶ Adhere to control description sticker in operator's cab.



#### DANGER

Machine tipping over!  
Danger to life.

▶ Work with spotter.

▶ Adhere to swapped steering directions.

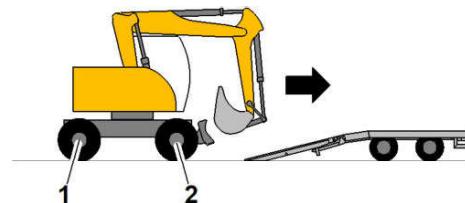

Fig. 799: Driving machine onto low-loader

1 Oscillating axle

2 Rigid axle

▶ Align machine with loading ramp.

▶ Turn operator's cab over rigid axle 2.

▶ Drive slowly onto low loader with rigid axle 2 first.



- ▶ Switch on hazard light system: Press *hazard light system* key.
- ▶ Switch on vehicle illumination.
- ▶ Make sure that involved persons wear warning clothing.
- ▶ Secure accident area.
- ▶ Secure machine with chocks to prevent it rolling away.
- ▶ Uncouple transmission. (For more information see: [3.10.4 Transmission, page 240](#))

**DANGER**

Machine rolling away!  
Danger to life.

- ▶ Exclusively use suitably dimensioned towing devices.
- 
- ▶ Mount towing device with pin **4** and securing pin **5** to coupling **1** of undercarriage.
  - ▶ Connect towing device to towing machine.
  - ▶ Store chocks.
  - ▶ Make sure that no one is between machine and towing vehicle.
  - ▶ Turn uppercarriage in travel direction.
  - ▶ Position working attachment in travel position.
  - ▶ Tow machine with caution and circumspection.

## Parking machine with uncoupled transmission

**DANGER**

Insufficient braking effect!  
Danger to life.



If transmission is uncoupled:

- ▶ Make sure that no unauthorised persons are in the danger area.
- ▶ Secure machine to prevent use.

**Note**

When transmission is uncoupled, the parking brake does not function!

- ▶ Use warning sign to draw attention to insufficient braking effect.
- 
- ▶ Park machine on level and firm ground.
  - ▶ Secure machine with chocks to prevent it rolling away.

Symbol	Meaning	Effect, characteristic	Remedy
	Wind speed too high.	Working area is restricted.	Park and secure machine.
	Operator code is incorrect.	Machine is blocked.	Use correct operator code.

Tab. 78: Warning symbols

Fuse	Consumer	Rating [A]
F10	Reserve, terminal 15	
F11	Supply voltage: Y50, power reduction pump 1, Y414 pressure reduction A-side, Y414-2 pressure reduction B-side, Y417-1 flow reduction A-side, Y417-2 flow reduction B-side, Y447 lowering of control pressure, Y451 slewing gear fine control, Y546 adjustable boom cylinder, proportional	15
F12	Supply voltage: Y24 crawler fast gear, Y353 travel, proportional, Y545 high pressure circuit, proportional, Y547 turning grapple, proportional, Y560 lateral boom adjustment, proportional, Y552 joystick steering left, Y553 joystick steering right, Y596 support, proportional	15
F13	Supply voltage: E178 beacon, rotary stage, E1.1-E1.4 headlights, working attachment	15
F14	Supply voltage: H9 horn, M8 central lubrication system	15
F15	Power supply Ausgangsmodule A201, A217 und Eingangsmodule A52	5
F16	Supply voltage, sensors A201, A215, A218	3
F17	Supply voltage: Y7 slewing brake, Y212 shut-off, retracting stick, Y480 retracting adjustable boom cylinder, Y481 extending adjustable boom cylinder, E4 travel light right, E151 working headlight, counterweight, E191 brake light right, E192 brake light left, H33 acoustic warning	15
F18	Supply voltage: Y62 forward travel, Y63 reverse travel, Y233 shut-off, extending stick, Y385-1 high pressure circuit switch-over, Y385-2 tilt bucket in, Y603 pressure increase, slewing gear	15
F19	Supply voltage: Y22 turning grapple left, Y23 turning grapple right, Y237 shut-off lift up, Y524 shut-off lift down, Y484 high pressure circuit A-side, Y485 high pressure circuit B-side	15
F20	Reserve, terminal 15	

Tab. 80: Fuse strip A214.XF2

Fuse	Consumer	Rating [A]
F1	Not occupied	
F2	Not occupied	
F3	SCR heating tank line, SCR heating injector	15
F4	Not occupied	
F5	Not occupied	
F6	Refuelling pump	25
F7	Hazard light	7.5
F8	Engine control unit controller	10

# 5 Maintenance

## 5.1 Inspection and maintenance schedule

### General information

Abbreviations used in this section: h = operating hours

Shorten maintenance intervals according to operating conditions, for example:

- Dust intensive application
- Oil quality
- Fuel quality

Make sure lubricants, fluids and replaced parts are disposed of safely and in eco-friendly manner. Adhere to country-specific directives applicable in country of use and to relevant applicable laws.

The service packages in the spare parts catalogue contain the spare parts required for maintenance tasks.

Symbols	Affected employees
Filled-in symbols	Machine owner or their maintenance staff that perform maintenance tasks independently
Empty symbols	Trained staff authorised by Liebherr

Tab. 88: Meaning of symbols

## 5.3 Fuels, lubricants and operating fluids

### 5.3.1 General information about lubricants and fuels

#### General questions

General questions can be addressed to the Liebherr Lubricant Hotline via email.

Liebherr Lubricant Hotline (email): <https://lubricants.liebherr.com>

#### Safety data sheets

Safety data sheets for lubricants and fuels are available online from the Liebherr lubricants portal.

Liebherr lubricants portal: <https://lubricants.liebherr.com>

#### Technical data sheets

Technical data sheets for lubricants and fuels are available online from the Liebherr lubricants portal.

One-time registration is required in order to access technical data sheets.

Liebherr lubricants portal: <https://lubricants.liebherr.com>

#### Specific Liebherr standards

Specific Liebherr standards for lubricants and fuels are available from the technical customer service at the relevant manufacturing plant.

### 5.3.2 Diesel fuels

#### Liebherr recommendation

Approved diesel fuels in line with DIN EN 590, ASTM D 975 1–D/2–D	Diesel engine stage V	Diesel engine stage IV or Tier 4f	Power band I/H as per Regulation ECE-R.96 (stage 3A, TIER III, CHINA III equivalent)
Maximum sulphur content	Up to 10 ppm	Up to 15 ppm	Up to 5000 ppm <sup>21)</sup>
Lubrication properties at 60 °C	400 µm	460 µm	
Minimum cetane number	45	45	

Tab. 92: Minimum quality requirements

Do not mix diesel fuel with fuel additives.

<sup>21)</sup> The sulphur content in the fuel determines the change interval in dependence on the quality of the engine oil.

## 5.4 Access points for maintenance work

### 5.4.1 Access points on uppercarriage



Fig. 903: Access points on uppercarriage

No.	Access point	Access to
1	Left side door	Air filter, battery main switch, servo control unit, main fuses, electric cabinet, grease container
2	Cover plate	Exhaust muffler, diesel particulate filter, SCR module
3	Engine bonnet	Diesel engine, fuel pre-filter, fuel fine filter, oil filter, hydraulic pumps, radiator, coolant container

Tab. 124: Access points on uppercarriage

## 5.7 Complete machine

### 5.7.1 Checking machine for proper condition and tightness

---

**NOTICE**

Incorrect check!  
Damage to machine.

- ▶ Perform visual inspections as per maintenance and inspection schedule.
  - ▶ Check machine for proper condition.
  - ▶ Check machine for tightness.
  - ▶ Check machine for damage.
- 

Make sure the following preconditions are met:

- Machine is in maintenance position.

#### Visual inspection before putting into service

- ▶ Before putting machine into service, always perform inspection tour.
- ▶ Perform maintenance tasks as per maintenance and inspection schedule every 8-10 h and 50 h.

#### Visual inspection during maintenance tasks

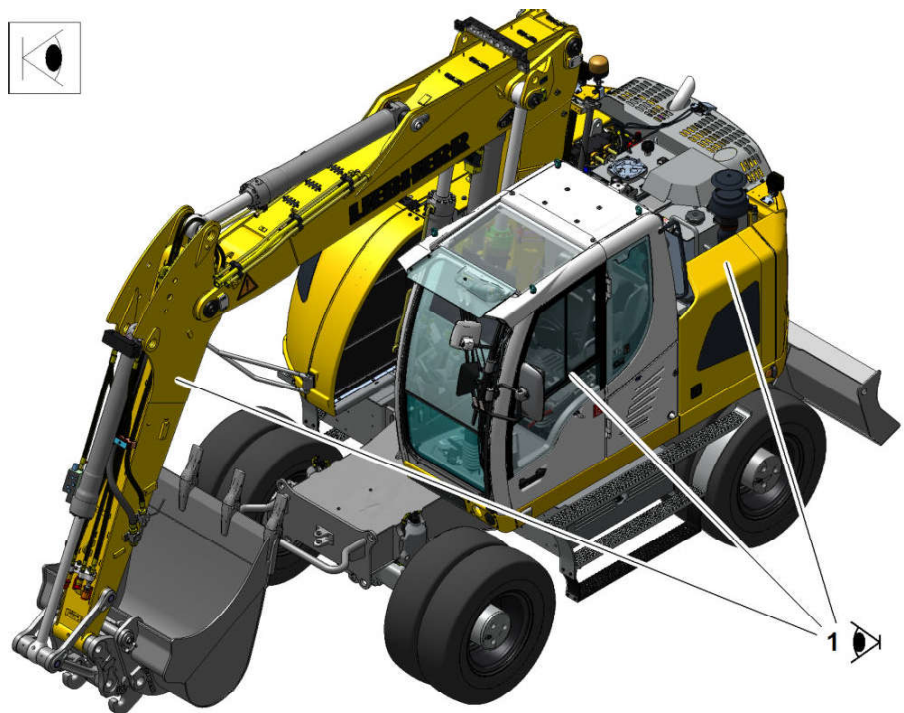

Fig. 907: Visual inspection of complete machine

	Machine	Size	Specific type	Serial number
Bulldozer	PR	756	1312	11290

Tab. 134: Examples, Liebherr machines

### Oil quantity in system

- ▶ Enter oil quantity of entire system.



#### Note

For filling quantities see chapter 030.2.

### Sampling information

- ▶ Enter component of sampled fuel or operating fluid.

### Machine location / note

If machine is operated at site with complication factors:

- ▶ Enter complication factor.

Examples of complicating factors:

- Working in extreme climate zones
- Working at strongly varying altitudes
- Working in bodies of water
- Working in dust intensive application

### Customer details

#### Kunde Customer / Client

Kundennummer Customer number	.....
Firma Company	.....
Name Name	.....
Straße, Postfach Street, P.O. Box	.....
Land, PLZ, Ort Country, ZIP, City	.....
Telefon, Mobil Phone, Mobile	.....
E-Mail Email	.....
Probenentnahme durch Sampling by	.....
Probe betrifft Firma Sample relates to	.....

Fig. 917: Customer details

- ▶ Enter customer details.

LHB/12211187/01/2020-04-22/en

**NOTICE**

Bowl 2 not lying correctly against filter housing 1!  
Leaking filter system. Damaged clamps 4.

- ▶ Make sure that the bowl 2 is in contact with the filter housing 1 all around the circumference.
- ▶ Tighten clamps 4 without great effort.

- ▶ Close clamps 4.

### 5.8.8 Regenerating exhaust system

#### Exhaust gas treatment menu



**DANGER**

Hot exhaust gases!  
Danger to life.

- ▶ Exclusively regenerate exhaust system outdoors.
- ▶ Make sure that no flammable materials are in the vicinity.

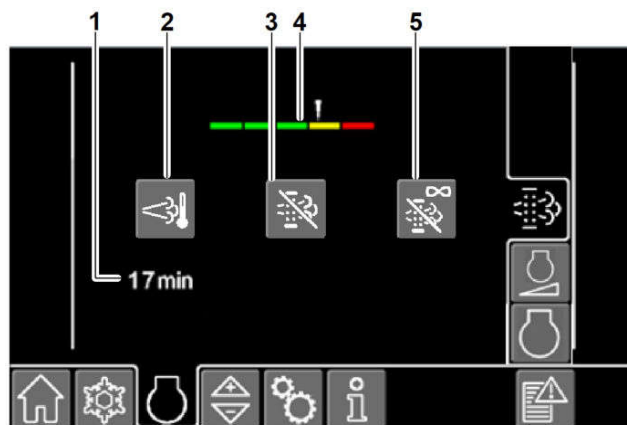

Fig. 926: Exhaust gas treatment menu

- |   |   |   |                           |
|---|---|---|---------------------------|
| 1 | Remaining regeneration time                             | 4 | Blocking regeneration     |
| 2 | Activating regeneration                                 | 5 | Deactivating regeneration |
| 3 | Diesel particulate filter contamination levels (option) |   |                           |

	Stage 1	Stage 2	Stage 3	Stage 4	Stage 5
Contami- nation level					

LHB/12211187/01/2020-04-22/en

**NOTICE**

Escaped oil!  
Environmental pollution.

- ▶ Collect oil in suitable receptacle.
  - ▶ Dispose of discharged oil in eco-friendly manner.
- 
- ▶ Remove existing covers. (For more information see: [5.4.2 Access points under the uppercarriage, page 290](#))
  - ▶ Depressurise hydraulic tank. (For more information see: [Depressurising hydraulic tank, page 326](#))
  - ▶ Remove protective cap from suction side drain valve **4**.
  - ▶ Place suitable receptacle under suction side drain valve **4**.
  - ▶ Place free end of drain hose **3** in receptacle.
  - ▶ Screw drain hose **3** onto suction side drain valve **4** until oil is discharged slowly.
  - ▶ Monitor hydraulic oil level, work with assistant if necessary.
- When required hydraulic oil level is reached:
- ▶ Remove drain hose **3** from suction side drain valve **4**.
  - ▶ Dispose of hydraulic oil in eco-friendly manner.
  - ▶ Screw protective cap onto suction side drain valve **4**.

### 5.10.3 Hydraulic tank: Draining water and sediments

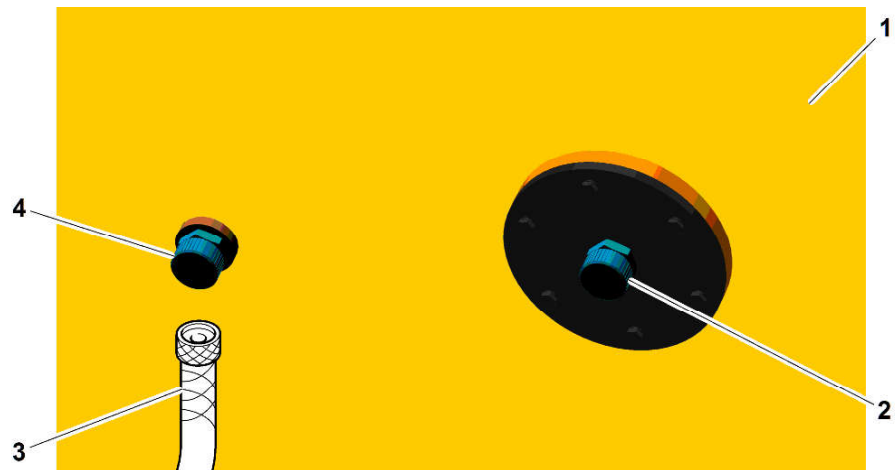

Fig. 952: Hydraulic tank drain valves

- |   |                         |   |                          |
|---|-------------------------|---|--------------------------|
| 1 | Hydraulic tank          | 3 | Drain hose               |
| 2 | Return side drain valve | 4 | Suction side drain valve |

- |  |  |
|--|--|
| <p>3 6 temperature levels temperature display (for emergency mode of automatic air conditioning)</p> <p>4 12 temperature levels temperature display (for air conditioning)</p> <p>5 Raise temperature button</p> <p>6 Operating status of air outlets</p> <p>7 Head area air outlets button</p> <p>8 Chest area air outlets button</p> | <p>11 Heating and air conditioning menu</p> <p>12 Lower blower power button</p> <p>13 Automatic mode button (not for emergency mode of automatic air conditioning and air conditioning)</p> <p>14 ECON button (not for emergency mode of air conditioning)</p> <p>15 Recirculated air button</p> <p>16 Defrosting and defogging button</p> |
|--|--|

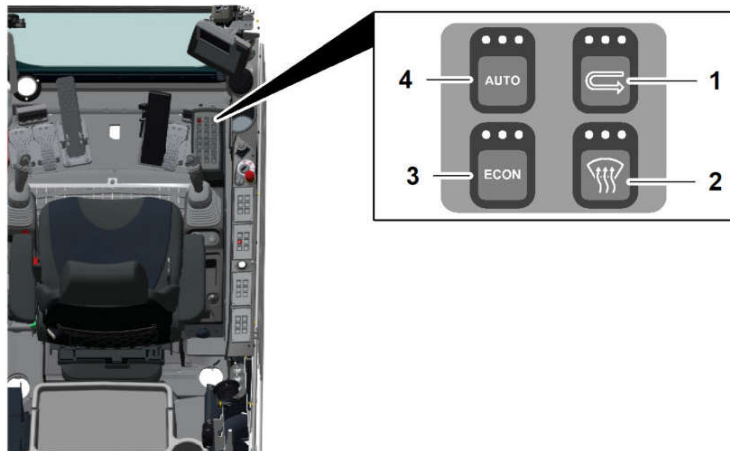

Fig. 960: Operation

- |                                |                      |
|--------------------------------|----------------------|
| 1 Recirculated air key         | 3 ECON key           |
| 2 Defrosting and defogging key | 4 Automatic mode key |

- ▶ Start diesel engine.
- ▶ Run machine warm. (For more information see: [3.4.9 Bringing machine to operating temperature, page 155](#))
- ▶ Open air outlets in operator's cab.
- ▶ Switch on automatic mode.



- ▶ Switch on defrosting and defogging.
- ▶ Switch on recirculated air.
- ▶ Check heating air flow for sufficient air outlet output.
- ▶ Clean air outlet if necessary.

LHB/12211187/01/2020-04-22/en

CLICK HERE TO **DOWNLOAD** THE COMPLETE MANUAL

- Thank you very much for reading the preview of the manual.
- You can download the complete manual from: [www.heydownloads.com](http://www.heydownloads.com) by clicking the link below



- Please note: If there is no response to CLICKING the link, please download this PDF first and then click on it.

CLICK HERE TO **DOWNLOAD** THE COMPLETE MANUAL