

Operation and Maintenance Manual

GALEO

PC300LC-7E0

PC300HD-7E0

HYDRAULIC EXCAVATOR

SERIAL NUMBERS **PC300LC-7E0** **A88001** and UP
PC300HD-7E0 **A86001**

This material is proprietary to Komatsu America Corp. and is not to be reproduced, used, or disclosed except in accordance with written authorization from Komatsu America Corp.

It is our policy to improve our products whenever it is possible and practical to do so. We reserve the right to make changes or add improvements at any time without incurring any obligation to install such changes on products sold previously.

Due to this continuous program of research and development, periodic revisions may be made to this publication. It is recommended that customers contact their distributor for information on the latest revision.

CLICK HERE TO **DOWNLOAD** THE COMPLETE MANUAL

- Thank you very much for reading the preview of the manual.
- You can download the complete manual from: www.heydownloads.com by clicking the link below



- Please note: If there is no response to CLICKING the link, please download this PDF first and then click on it.

CLICK HERE TO **DOWNLOAD** THE COMPLETE MANUAL

INTRODUCTION

PRE-OPERATIONAL CHECKS	1-18
STARTING YOUR WORK OPERATIONS	1-18
WORK SITE HAZARDS	1-18
AVOIDING DANGEROUS SITUATIONS	1-19
DIGGING HARD ROCKY GROUND	1-22
SUDDEN LEVER SHIFTING HIGH SPEED TRAVEL	1-22
WORKING CLEARANCES	1-23
OPERATIONS ON SLOPES	1-24
OPERATIONS ON SNOW	1-24
RULES FOR ROAD TRAVEL	1-25
TRAVELING WITH CARRIAGE REVERSED	1-25
TRAVEL ON SLOPES	1-26
PARKING THE MACHINE	1-27
PRECAUTIONS DURING MAINTENANCE OPERATIONS	1-28
WARNING TAGS	1-28
EQUIPMENT STORAGE	1-28
WORKING UNDER THE MACHINE	1-29
USING DROP LAMPS	1-29
KEEPING THE MACHINE CLEAN	1-29
PERFORMING GENERAL MAINTENANCE PROCEDURES	1-30
RUNNING THE ENGINE DURING MAINTENANCE	1-31
PROPER TOOLS	1-31
WELDING, GRINDING OR CUTTING	1-32
ADJUSTING TRACK TENSION	1-32
DO NOT DISASSEMBLE RECOIL SPRINGS	1-32
WHEN USING HAMMER	1-32
RULES FOR REFUELING THE MACHINE	1-33
COOLING SYSTEM PRECAUTIONS	1-33
BATTERY PRECAUTIONS	1-34
STARTING ENGINE WITH BOOSTER CABLES	1-34
STARTING PRECAUTIONS	1-34
HIGH PRESSURE HOSES	1-35
SAFETY HANDLING HIGH-PRESSURE HOSES	1-35
PRECAUTION FOR HIGH FUEL PRESSURE	1-35
HIGH TEMPERATURES AREAS	1-35
DISPOSAL OF WASTE MATERIALS	1-36
ACCUMULATOR	1-36
CRITICAL PARTS	1-36
HIGH VOLTAGE	1-37
TOWING	1-37
SAFETY RULES FOR TOWING	1-37

OPERATION

GENERAL VIEWS	2-2
VIEW OF MACHINE	2-2
VIEW CONTROLS AND GAUGES	2-3
MACHINE MONITOR SYSTEM	2-4
MONITOR BEZEL LAYOUT	2-4

SAFETY LABELS

1. Caution Before Operating Or Maintaining Machine (09651-03001)

Improper operation and maintenance can cause serious injury or death

Read manual and tables before operation and maintenance. Follow instructions and warnings in manual and in tables on machine.

Keep manual in machine cab near operator. Contact Komatsu distributor for replacement manual.

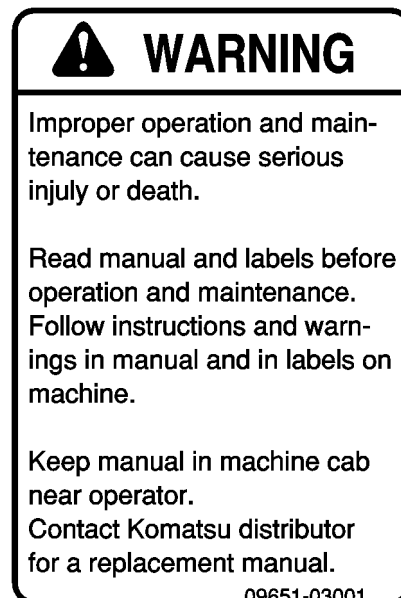

2. Caution Before Operating (09802-03000)

To prevent SEVERE INJURY or DEATH, do the following before moving the machine or its attachments:

- Honk horn to alert people nearby.
- Be sure no one is on or near machine or in swing area.
- Rotate cab for full view of travel path if it can be done safely.
- Use spotter if view is obstructed.

Follow above even if machine is equipped with travel alarm and mirrors.

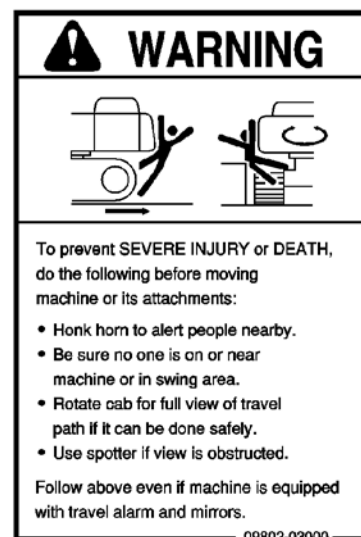

3. Warning For Leaving Operator's Seat (09654-03001)

To avoid hitting unlocked operation levers, lower equipment to ground and move SAFETY LOCK LEVER (located near seat) to LOCK position before standing up from operators seat.

Sudden and unwanted machine movement can cause serious injury or death.

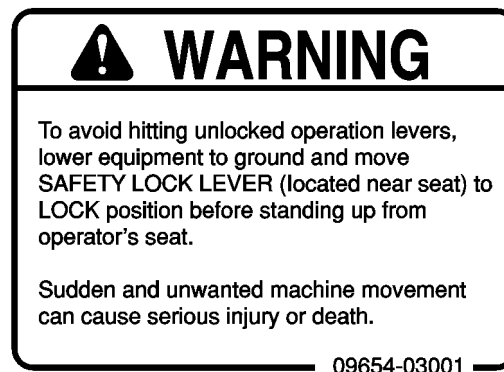

FIRE COMING FROM ELECTRIC WIRING

Short circuits in the electrical system can cause fire.

Always keep electric wiring connections clean and securely tightened.

Check the wiring every day for looseness or damage to the wire insulation.

- Tighten any loose connectors or wiring clamps.
- Repair or replace any damaged, pinched or chaffed wiring.
- After market radios or other electrical operated equipment in the cab must be fused close to the power supply

FIRE COMING FROM HYDRAULIC LINE

- Check that all the hose and tube clamps, guards, and cushions are securely fixed in position.
- If they are loose, they may vibrate during operation and rub against other parts. This may lead to damage to the hoses, and cause high-pressure oil to spurt out, leading to fire damage or serious injury.
- Check for oil leaks daily and repair them immediately.

WINDSHIELD WASHER FLUID

- Use an automotive type washer fluid in the windshield washer system.
- Never use flammable fluids in the windshield washer system

ACTION IF FIRE OCCURS

- If a fire occurs, escape from the machine as follows:
- Do not attempt to move the machine or continue operations.
- Turn the start switch OFF to stop the engine.
- Use the handrails and steps to get off the machine.
- Immediately call for help.
- When using a fire extinguisher, always aim the extinguisher at the base of the fire
- If an optional fire extinguishing system is in place be finality with it's operating procedures.

DUST HAZARD PRECAUTIONS

Dust can be hazardous to your health if inhaled. Komatsu does not use asbestos in its products. There is a danger imitation products may contain asbestos. If you have to handle materials containing asbestos fibers or other dust materials during demolition operations, always do as follows.

- Never use compressed air for cleaning.
- Use water to keep down the dust when cleaning.
- If there is a danger there may be asbestos dust in the air, operate the machine with the wind to your back whenever possible.
- Use an approved respirator.
- Do not allow any other person into the area during operation.

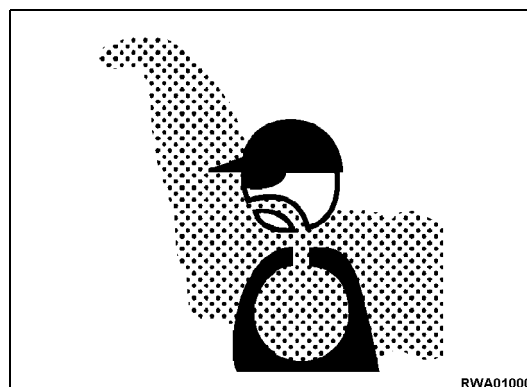

WORKING CLEARANCES

It is always a good idea to be aware of your clearances around, in front, behind and especially above your work area or travel rout.

Some basic safety precautions to prevent risk are:

- When working or traveling in an area where clearances are a problem, travel at a slow cautious speed.
- If you are not sure of your clearances, request the aid of another person who can guide or warn you if you get too close to objects.
- Be aware of the dangers when working around overhead electrical lines, high humidity may pose an electrical hazard even if your machine clears the overhead power lines.
- If your machine should come in contact with overhead electrical lines, stop the machine and remain on the machine until the power company clears the lines and it is safe to get off or move the machine.
- If you must leave the machine, jump free of the machine (do not touch it) do not allow anyone on the ground to touch the machine.
- If low power lines pose a greater hazard, ask the power company to remove the lines until your work is finished.

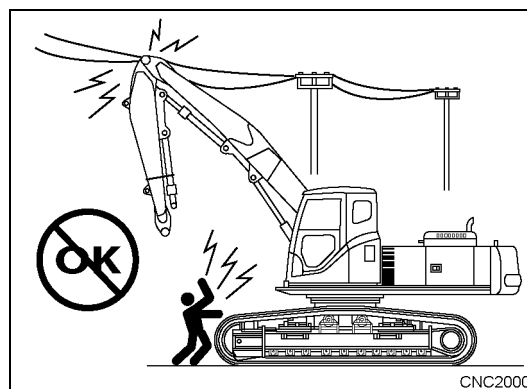
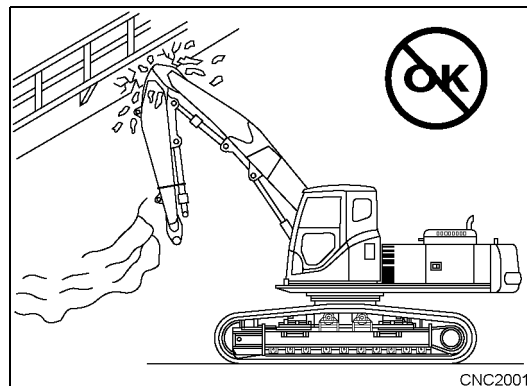

Cable Voltage	Min. Safe Distance	
	m	ft
100 V - 200 V	Over 2 m	(7 ft)
6,600 V	Over 2 m	(7 ft)
22,000 V	Over 3 m	(10 ft)
66,000 V	Over 4 m	(14 ft)
154,000 V	Over 5 m	(17 ft)
187,000 V	Over 6 m	(20 ft)
275,000 V	Over 7 m	(23 ft)
500,000 V	Over 11 m	(36 ft)

RULES FOR REFUELING THE MACHINE

Always clean up any spills. Grease, fuel, oil or coolant spills can pose a trip hazard if not mopped up immediately.

Be sure you are adding the correct fluids to the proper location. Mixing fluids can cause damage to internal components.

When refueling or adding any fluids, be sure you are in a well ventilated area. Never smoke or allow open flames near you while you are refueling the machine.

Never mix gasoline with diesel fuel. Gasoline is extremely flammable and could cause an explosion. Do not fill the fuel tank completely, leave room for the fuel to expand.



COOLING SYSTEM PRECAUTIONS

Never add coolant to a hot or warm engine. Always allow the engine time to cool down completely before opening the radiator cap.

Never dump used coolant on the ground, in a lake, stream or in a sewer system. EPA Law requires these fluids to be captured and recycled properly. Failure to do so is in violation of the law.

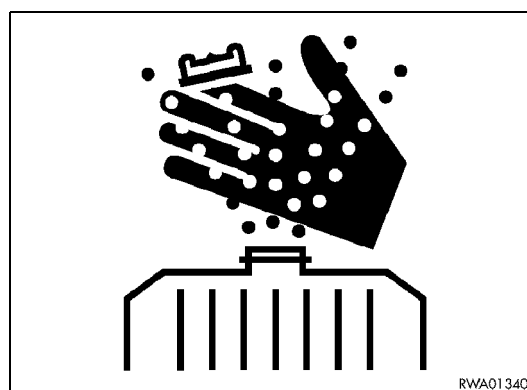

BASIC OPERATION OF MACHINE MONITOR

The following is an explanation of devices needed for operating the machine. To perform suitable operations correctly and safely, it is important to completely understand methods of operating the equipment, and the meanings of the displays.

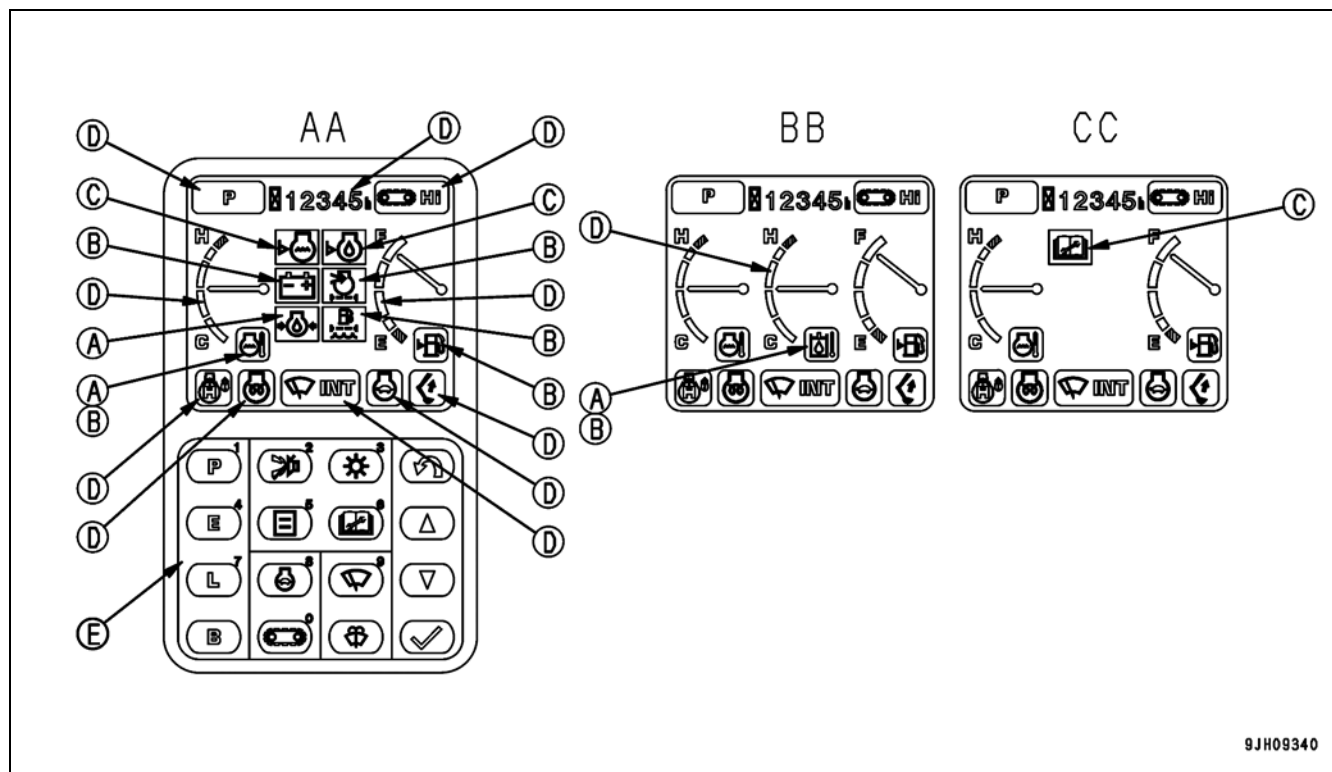

AA: Screen with all lamps lit

BB: Screen for normal operation

CC: Maintenance warning screen

A. Emergency monitors

C. Basic check monitors

E. Monitor switches position

B. Caution monitors

D. Meter display portion

ENGINE OIL LEVEL MONITOR

Monitor (2) warns the operator that the oil level in the engine oil pan has dropped.

If oil level in the engine oil pan is low, the lamp lights up red, so check the oil level, and add oil.

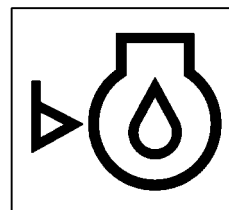

9JH01663

MAINTENANCE INTERVAL MONITOR

Monitor (3) lights up to warn the operator that the set time has passed since maintenance was last performed.

This monitor screen goes out after 30 seconds and returns to the normal operation screen.

For details on the method of checking the maintenance interval, see "MAINTENANCE" section.

If it is desired to change the maintenance interval settings, have your Komatsu distributor change the interval settings.

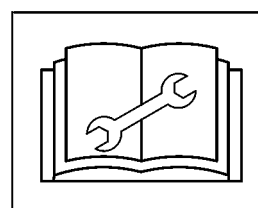

9JH02347

WIPER SWITCH

This switch (4) operates the wiper for the front glass.

Each time the switch is pressed, it changes ON → INT → stop (OFF).

Display (GG) INT is illuminated	Wiper moves intermittently
Display (GG) ON is illuminated	Wiper moves continuously
Display (GG) OFF is illuminated	Wiper stops

Remark

Each time the wiper switch is operated, the mode is displayed in the center of the monitor display (GG). The screen returns to the normal screen (BB) after 2 seconds.

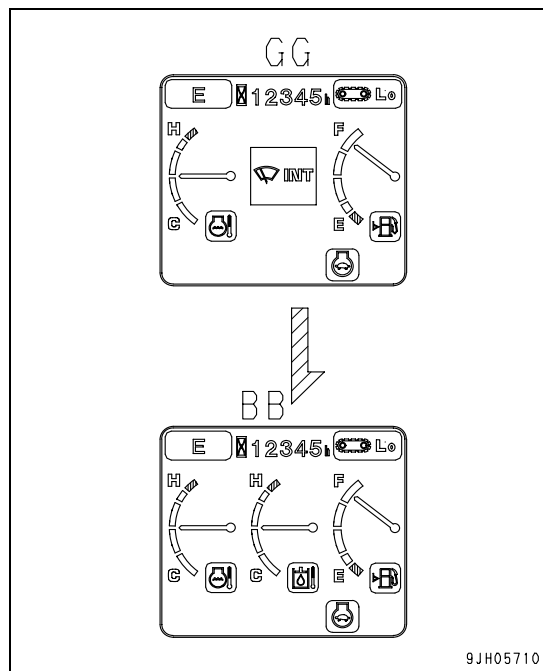
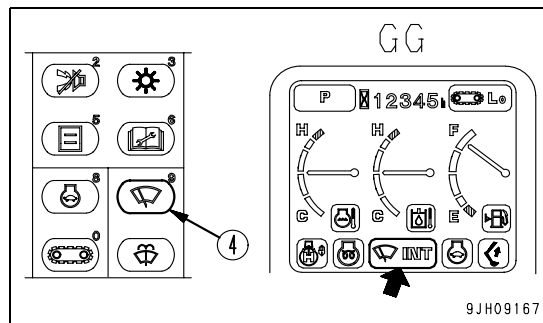

WINDOW WASHER SWITCH

When this switch (5) is kept continuously pressed, window washer fluid is sprayed out on the front glass. When the switch is released, the spray stops.

- If switch (5) is kept pressed when the wiper is stopped, the window washer fluid will spray out, and at the same time, the wiper will be actuated continuously. When switch (5) is released, the wiper will continue to operate continuously for 2 cycles, and will then stop.
- If the wiper is moving intermittently and switch (5) is kept pressed continuously, the window washer fluid will spray out, and at the same time, the wiper will be actuated continuously. When switch (5) is released, the wiper will continue to operate continuously for 2 cycles, and will then return to intermittent operation.

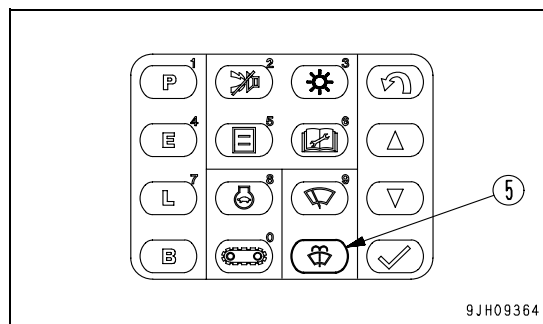

SWING LOCK SWITCH

⚠ WARNING

When traveling or when not using the swing operation, apply the swing lock.

On slopes, even when the swing lock switch is at the ON position, the weight of the work equipment may cause the upper structure to swing if the swing control lever is operated in the downhill direction.

This switch (4) is used to lock the upper structure so that it cannot swing.

ON position (actuated):	The swing lock is always applied, and the upper structure will not swing even if the swing is operated. In this condition, the swing lock lamp lights up.
OFF position (canceled):	The swing lock is applied only when all the control levers of the work equipment are at neutral; when any one of the control levers is operated, it is cancelled. The swing lock is actuated approximately 5 seconds after all the control levers are placed in the neutral position.

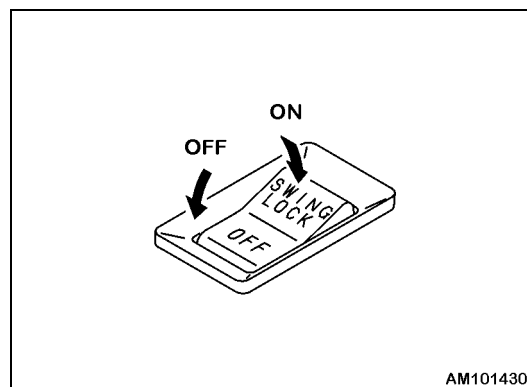

LAMP SWITCH

This switch (5) is used to light up the front lamps, working lamp, additional lamp at the top front of the cab, rear lamp, and monitor lighting.

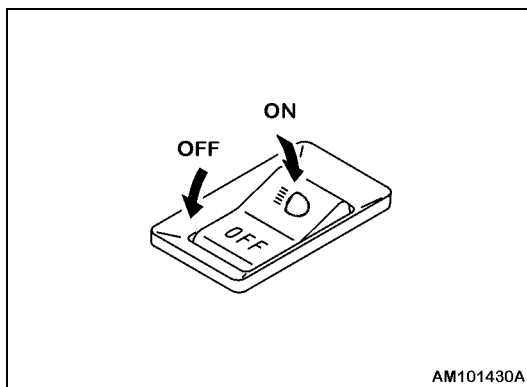

MACHINE PUSH-UP SWITCH

This switch (6) is used to switch the safety valve set pressure at the head end of the boom cylinder to two levels.

(a) Low-pressure setting:

The boom thrust force is weak, so the swaying of the chassis is small during digging operations, and digging operations can be carried out smoothly. This is used for general digging operations on normal ground, soft rock, or blasted rock.

(b) High-pressure setting:

The thrusting force of the boom becomes more powerful, so it is easy to escape from soft ground.

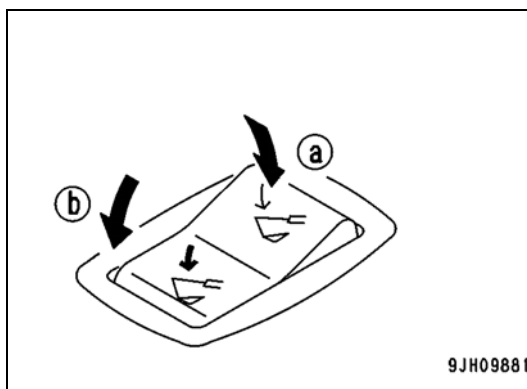

- Grip left and right knobs (A), and pull down lock lever (B) to release the lock.

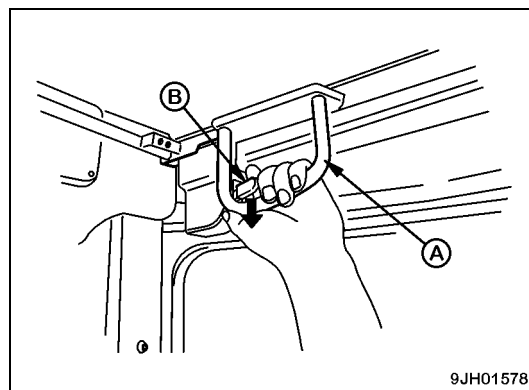

- Grip knob (C) at the bottom of the front window with your left hand and knob (D) at the top with your right hand,

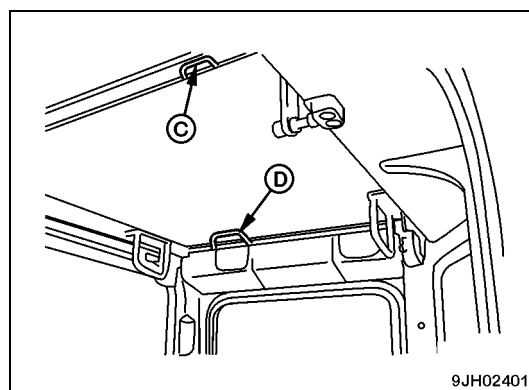

- Push the window to the front, then lower it slowly.

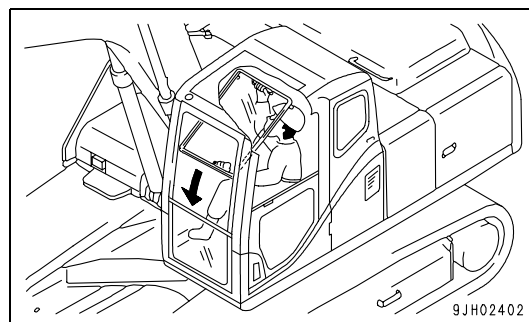

- When the bottom of the window reaches the top of the bottom window, push the top of the window to the front to push it against left and right lock catches (G) and engage the locks.

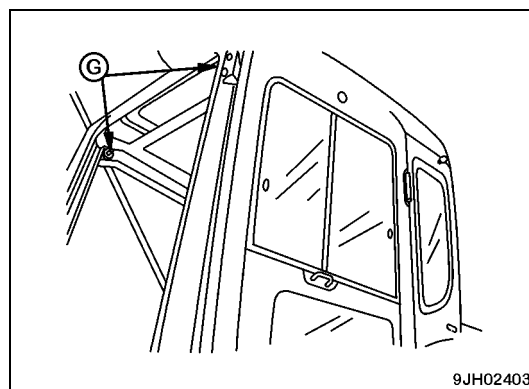

AUTO SWITCH

With this switch (5), the air flow, vents, and air source (RECIRC/FRESH) are automatically selected according to the set temperature.

This switch also acts as the air conditioner main switch.

- When auto switch (5) is pressed, the lamp at the top of the auto switch lights up.
- Normally, press this switch, then use temperature control switch (3) to set the temperature, and run the air conditioner under automatic control.
- When the control is switched from automatic operation to manual operation, it is then possible to operate the switch to change the air flow, vents, and air source (RECIRC/FRESH). When the manual control is used, the lamp at the top of the auto switch goes out.

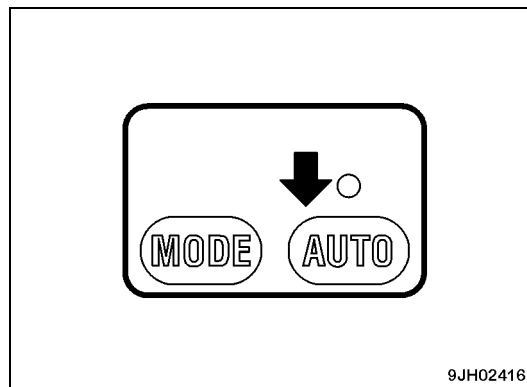

9JH02416

RECIRC/FRESH SELECTOR SWITCH

This switch (6) is used to switch the air source between recirculation of the air inside the cab and intake of air from the outside.

- When switch (6) is pressed, the lamp at the top of the selector switch lights up to show that air is being blown out.
- During automatic operation, the selection of inside air (RECIRC) and outside air (FRESH) is carried out automatically.

RECIRC	The outside air is shut off and only the air inside the cab is circulated. Use this position to carry out rapid cooling of the cab or when the outside air is dirty.
FRESH	Outside air is taken into the cab. Use this position to take in fresh air or when carrying out demisting.

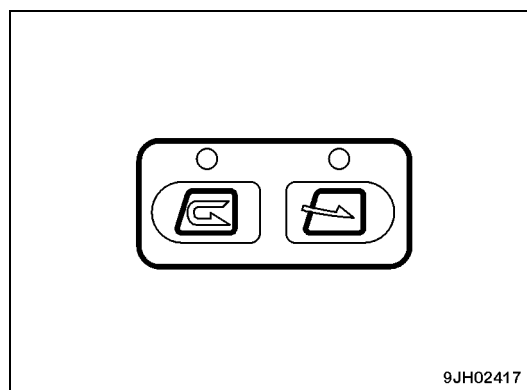

9JH02417

DISPLAY MONITOR

This display monitor displays the status of temperature setting (a), air flow (b), and vents (c).

- When OFF switch (1) is pressed, the display of temperature setting (a) and air flow (b) goes out, and operation stops.

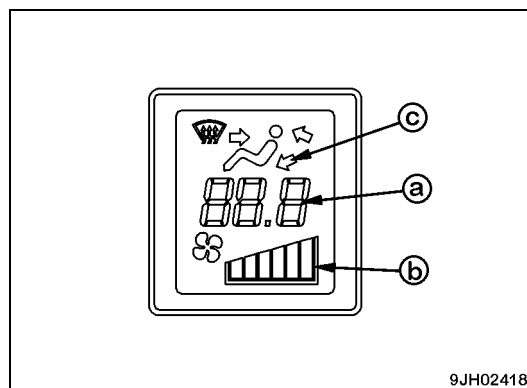

9JH02418

RADIO

EXPLANATION OF FEATURES

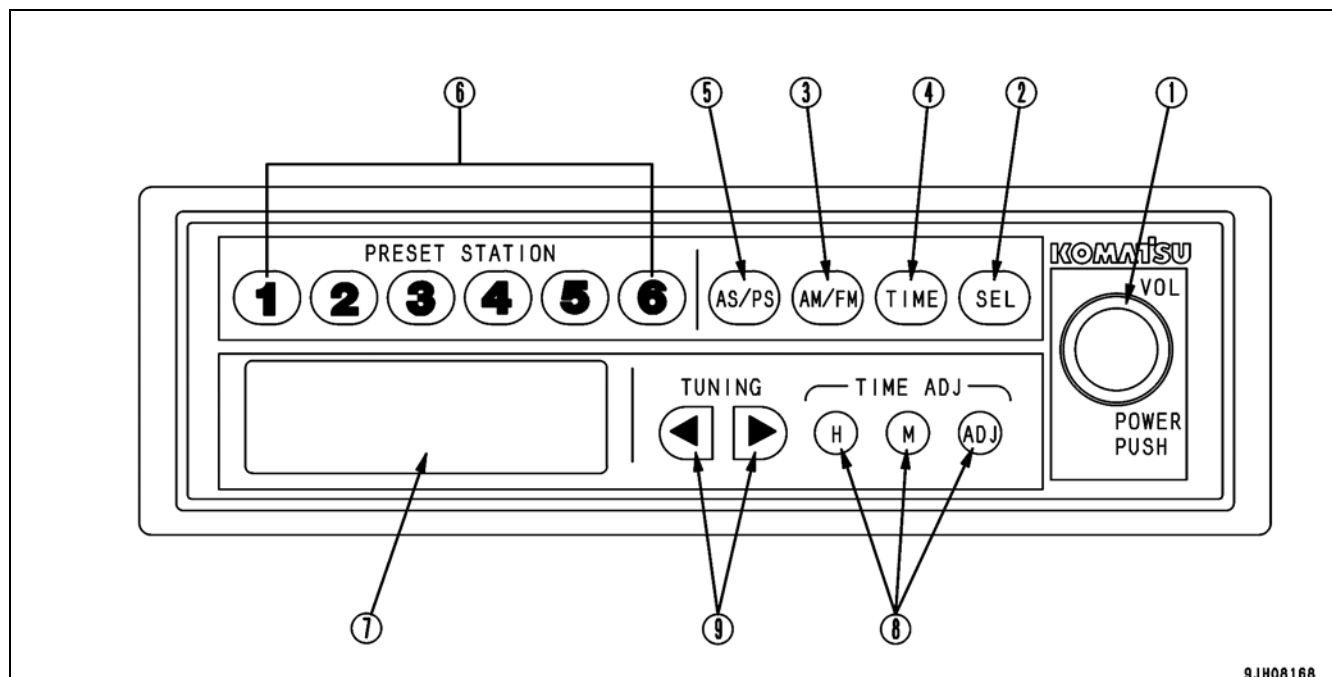

- | | |
|--|---------------------------|
| 1. Power switch/Volume control knob/Balance knob | 6. Preset station buttons |
| 2. SEL button | 7. Display |
| 3. FM/AM selector button | 8. Time set buttons |
| 4. Display selector button | 9. Tuning button |
| 5. AS/PS button | |

POWER SWITCH/VOLUME CONTROL/BALANCE KNOB

Press this knob (1) to turn the power for the radio on. The frequency is displayed on display (7). Press again to turn the power off.

Turn the knob to adjust the volume as follows.

- Turn CLOCKWISE to INCREASE volume
- Turn COUNTERCLOCKWISE to REDUCE volume

SEL BUTTON

Each time this button (2) is pressed, the mode changes as follows: VOL (volume) → BAS (bass) → TRE (treble) →

BAL. (balance). The mode is displayed on display (7). For details of each mode, see “PRESET STATION BUTTONS (1, 2, 3, 4, 5, 6) (PAGE 3-65)”.

FM/AM SELECTION BUTTON (AM/FM)

Press this button (3) to select the desired band.

Each time the button is pressed, the band changes FM → AM → FM...

CHECK AND DRAIN WATER SEPARATOR

1. Open the cover on the right side of the machine.
2. The water separator forms one unit with fuel pre-filter (1).
3. It is possible to judge the water level and amount of sediment by looking through transparent cap (2). If there is any water or sediment collected at the bottom, set a container to catch the drain water under drain hose (3).
4. Loosen drain valve (4) and drain the water.
5. When fuel starts to drain from drain hose (3), tighten drain valve (4) immediately.

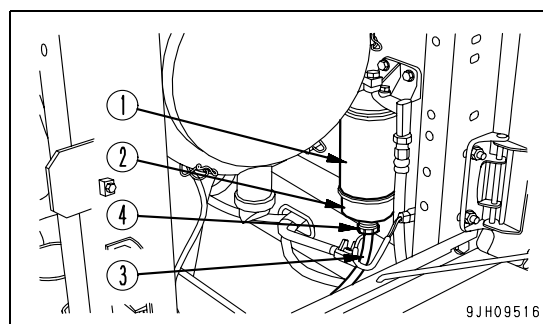

On this machine, a sensor is installed to detect if water is accumulated in transparent cap (2).

When the water separator monitor (5) lights up red on the machine monitor, it indicates that water is accumulated in transparent cap (2).

★ In this case also, use the procedure above to drain the water.

- If the water accumulated in transparent cap (2) freezes, the water separator monitor may not light up. After the engine is started, as the temperature around fuel pre-filter (1) increases, the frozen water will melt and the water separator monitor may suddenly light up. In cold areas, even if the water separator monitor does not light up, drain the water frequently.
- If the water inside transparent cap (2) freezes, check to be sure the frozen water has melted completely, then use the procedure above to drain the water.

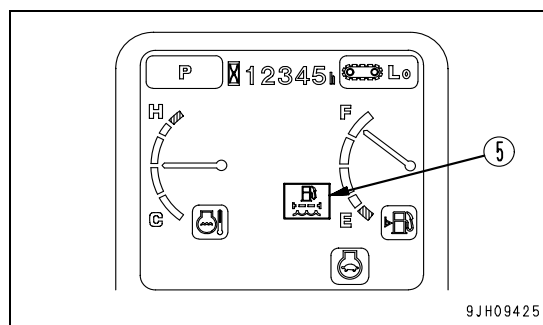

Remark

If transparent cap (2) is dirty and the contents cannot be easily seen, clean transparent cap (2) when replacing fuel pre-filter cartridge (1).

ADJUSTMENT OF DRAIN VALVE

If drain valve (4) is stiff, coat the O-ring portion of the drain valve with grease to make the movement smooth.

1. Turn valve (5) at the bottom of the fuel tank to the right to close it.

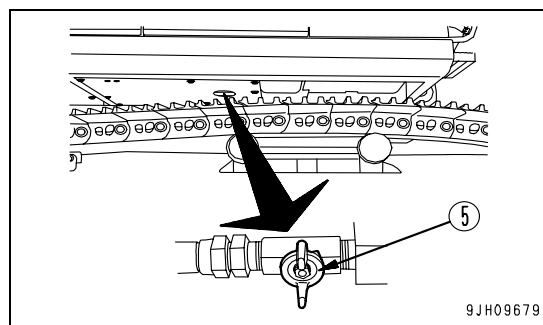

2. Set a fuel container under transparent cap (2), then remove drain valve (4).

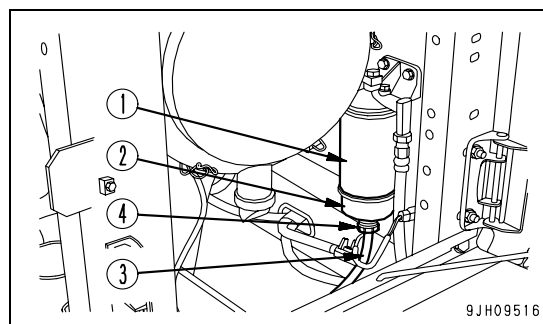

7. Press maintenance switch (18), check the item, then carry out maintenance immediately.

★ For details of the method of checking the maintenance interval, see “MAINTENANCE Section” in the Detailed controls and gauges.

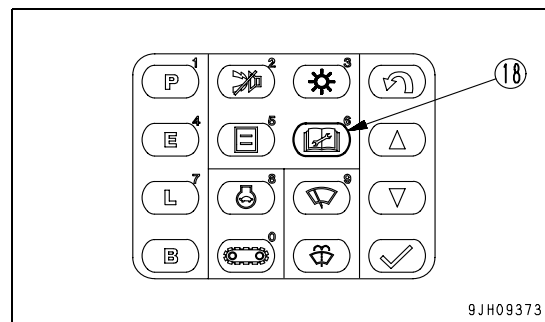

CLICK HERE TO **DOWNLOAD** THE COMPLETE MANUAL

- Thank you very much for reading the preview of the manual.
- You can download the complete manual from: www.heydownloads.com by clicking the link below



- Please note: If there is no response to CLICKING the link, please download this PDF first and then click on it.

CLICK HERE TO **DOWNLOAD** THE COMPLETE MANUAL

AFTER WARMING-UP OPERATIONS

1. Check to be sure hydraulic oil temperature monitor (7) displays green.

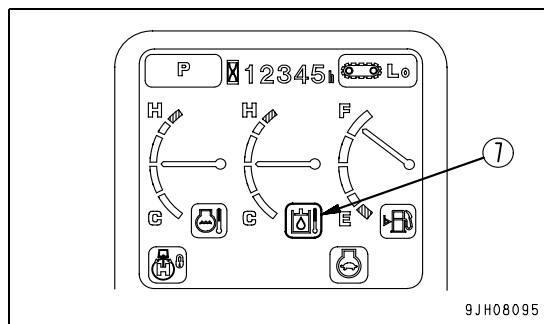

2. Push working mode selector switch (20) of the machine monitor to select the working mode to be used.

For details of the procedure for selecting the working mode, see “Working Mode Selector Switch (Basic Switch) (PAGE 3-22)”.

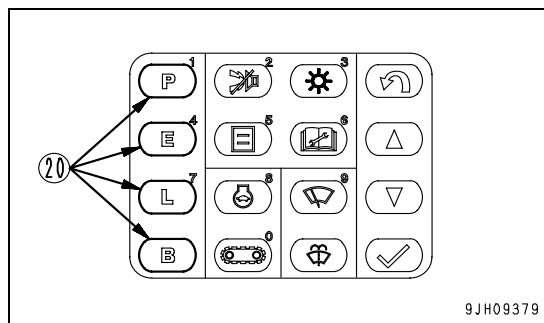

- Working mode monitor display

-P mode

For heavy-duty operations

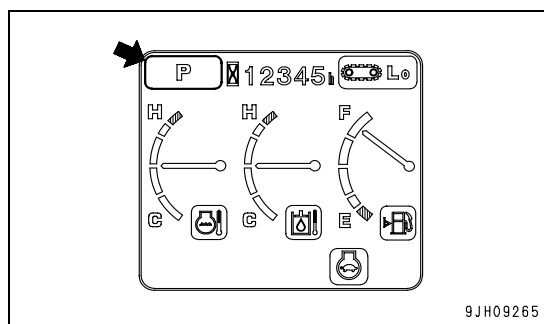

-E mode

For operations with emphasis on fuel economy

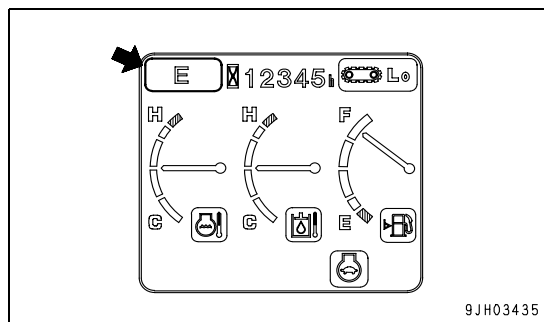

-L mode

For operations requiring fine control

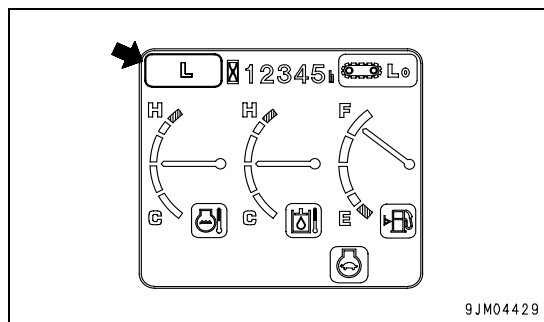

STOPPING MACHINE

! WARNING

Avoid stopping suddenly. Give yourself ample room when stopping.

1. Put the left and right travel levers (1) in the neutral position, then stop the machine.

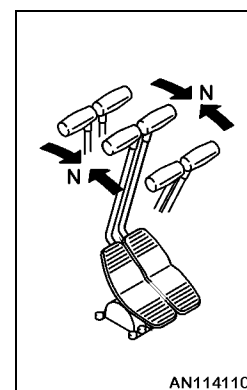
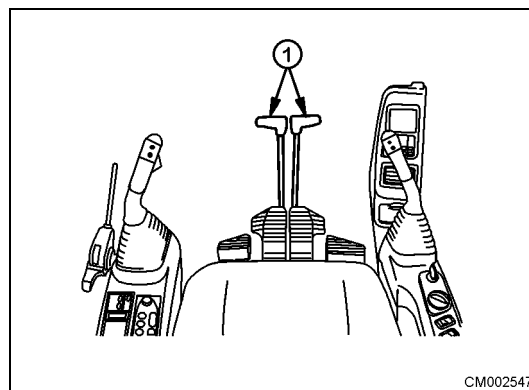

WORK EQUIPMENT OVERVIEW

! WARNING

If the lever is operated when the engine speed has been lowered by the auto-deceleration function, the engine speed will suddenly rise, operate the levers carefully.

- Use the control levers to operate the work equipment.
- Note that when the levers are released, they return to the HOLD position and the work equipment is held in that position.

ARM CONTROL

Move the left work equipment control lever to the front or rear to operate the arm in or out.

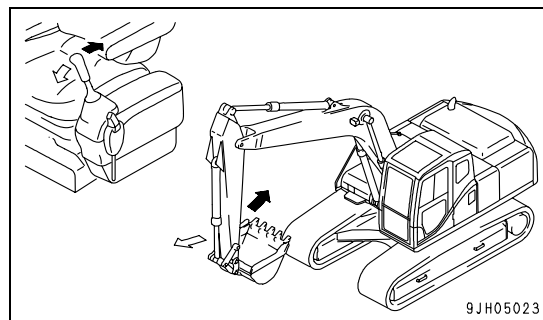

SWING CONTROL

Move the left work equipment control lever to the left or right to swing the upper structure.

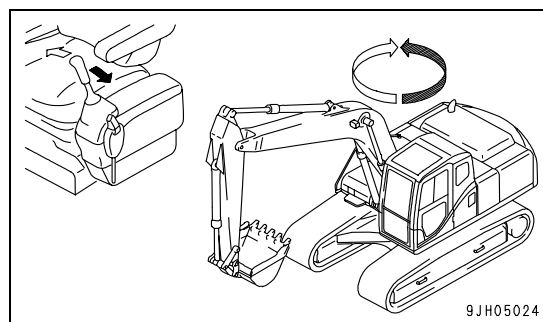

BOOM CONTROL

Move the right work equipment control lever to the front or rear to operate the boom up or down.

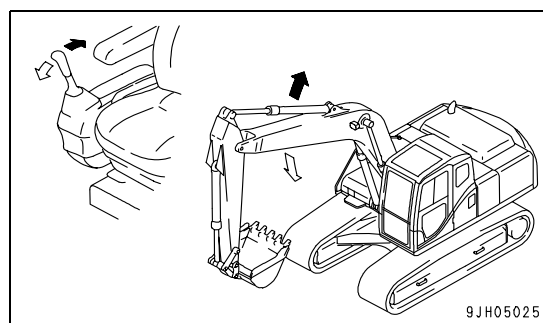

BUCKET CONTROL

Move the right work equipment control lever to the left or right to operate the bucket dump or curl.

If the work equipment control levers are returned to the neutral position when the machine is stopped, even if the fuel control dial is set to FULL, the auto-deceleration mechanism will act to reduce the engine speed to a mid-range speed.

The control circuit on this machine is equipped with an accumulator. Even if the engine is stopped, if the ignition switch key is turned to the ON position within 15 seconds after stopping the engine, and the lock lever is set to the FREE position, it is possible to use the control lever operation to lower the work equipment to the ground. This procedure can also be used for releasing the remaining pressure in the hydraulic cylinder circuits or for lowering the boom after loading the machine onto a trailer.

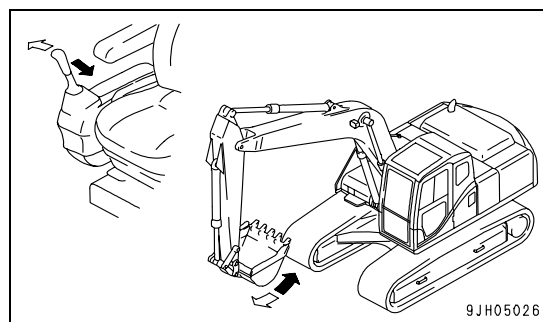

SECURING MACHINE

- Stow the antenna and reassemble the mirrors so that they are within the width of the machine.
- To prevent damage to the bucket cylinder during transportation, fit a wooden block at one end of the bucket cylinder to prevent it from touching the floor.
- Load the machine onto a trailer as follows:

1. Extend the bucket and arm cylinders fully, then lower the boom slowly.

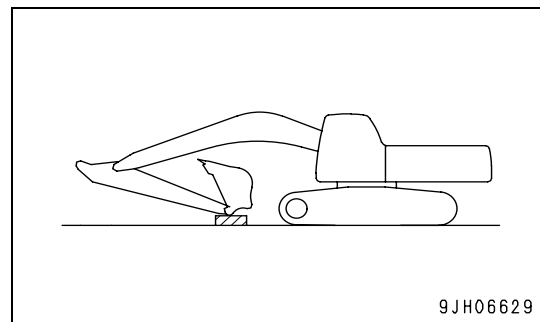

2. Set the lock lever securely to the LOCK position (L).
3. Stop the engine, then remove the key from the ignition switch.
4. Close all doors, windows, and covers. Lock the covers, caps, and doors fitted with locks.

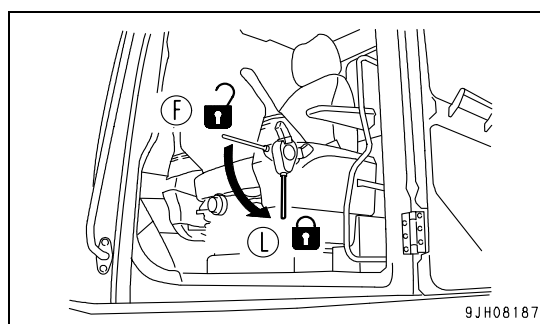

5. Place blocks under both ends of the tracks to prevent the machine from moving during transportation, and secure the machine with chains or wire rope of suitable strength.
6. Be particularly careful to secure the machine in position so it does not slip to the side.

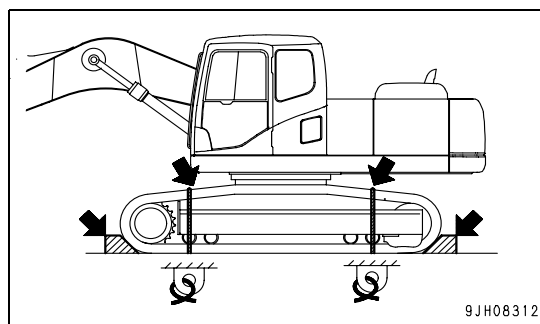

PRECAUTIONS ON PARTICULAR JOBSITES

- When carrying out digging operations in water, if the work equipment mounting pin goes into the water, grease it every time it comes out of the water.
- For heavy-duty operations and deep digging, grease the work equipment mounting pins every time before each operation. After greasing, operate the boom, arm, bucket, and blade several times, then grease again.

DISCHARGED BATTERY

! WARNING

It is dangerous to charge the battery while it is still mounted on the machine. Always remove the battery before charging it.

When checking or handling the battery, stop the engine and turn the ignition switch key to the OFF position.

The battery generates hydrogen gas, so there is danger of explosion.

Do not bring lighted cigarettes near the battery, or do anything that will cause sparks.

Battery electrolyte is diluted sulfuric acid, and it will attack your clothes and skin. If it gets on your clothes or on your skin, wash it off immediately with large amounts of water. If it gets into your eyes, wash it out with fresh water, and consult a doctor.

When handling batteries, always wear protective goggles and rubber gloves.

When removing the battery, first disconnect the cable from the ground (normally the negative (-) terminal). When installing, install the positive (+) terminal first.

If a tool touches the positive terminal and the chassis, there is danger that it will cause a spark, be extremely careful.

If the terminals are loose, there is danger that the defective contact may generate sparks that will cause an explosion.

When installing the terminals, install them tightly.

When removing or installing the terminals, check which is the positive (+) terminal and which is the negative (-) terminal.

Green rust around the terminals is a cause of self-discharge of the battery. Clean the terminals with sandpaper. After removing the rust, coat the terminals thinly with grease before installing.

When removing, disconnect the cable from the ground terminal first.

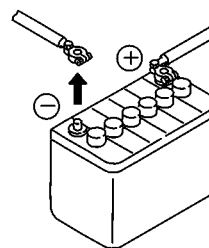

When installing, connect the cable to the positive (+) terminal first.

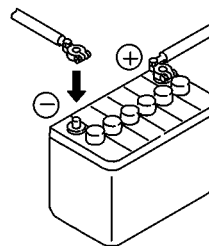

9EA00023

LONG TERM STORAGE

BEFORE STORAGE

Remark

When storing the machine, set the machine in the posture shown in the diagram on the right to protect the cylinder rod. (To prevent rusting of the cylinder rod)

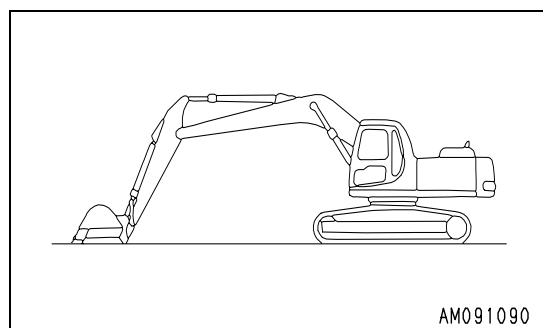

When putting the machine in storage for a long time, do as follows.

1. Clean and wash all parts, then store the machine indoors. If the machine has to be stored outdoors, select level ground and cover the machine with a sheet.
2. Completely fill the fuel tank, lubricate and change the oil before storage.
3. Apply a thin coat of grease to the metal surface of the hydraulic piston rods.
4. Disconnect the negative terminals of the battery and cover it or remove it from the machine and store it separately.
5. If the ambient temperature is expected to drop below 0°C (32°F), add antifreeze to the cooling water.
6. Lock each control lever and pedal with the lock lever and pedal lock.
7. Set the stop valve to the LOCK position on machines which can install attachments. Install a plug in the elbow.
8. Set the selector valve on the machines which can install attachments to the “Where no attachment is mounted” position.

DURING STORAGE

WARNING

If it is unavoidably necessary to carry out the rust-preventive operation while the machine is indoors, open the doors and windows to improve ventilation to prevent gas poisoning.

During storage, always operate the machine once a month so that a new film of oil will be coated over movable parts and component surfaces. At the same time, charge the battery.

For machines equipped with an air conditioner, run the air conditioner.

Rotate the tracks.

AFTER STORAGE

Remark

If the machine is to be used when the monthly rust prevention operation has not been carried out, please contact your Komatsu distributor.

When using the machine after long-term storage, do as follows before using it.

1. Wipe off all the grease coating the hydraulic cylinder rods.
2. Add oil and grease to all places.
3. When the machine has been stored for a long time, the moisture in the atmosphere will get into the oil. Check the oil at all parts before and after starting the engine. If there is water in the oil, change all the oil.

STARTING MACHINE

When starting the engine after long-term storage, cancel the automatic warming-up operation as follows.

1. Turn the ignition switch key to the ON position.
2. Turn the fuel control dial from the low idling (MIN) position to the full (MAX) position, hold it there for 3 seconds, then return it to the low idling (MIN) position and start the engine.

WEAR PARTS LIST

Wear parts such as the filter element, bucket tooth, etc. are to be replaced at the time of periodic maintenance or before their abrasion limits.

The wear parts should be changed as scheduled in order to use the machine economically.

For part change, Komatsu genuine parts should be used (excellent quality).

When ordering parts, please check the part number in the parts book and write them in the table below.

The parts in parentheses are to be replaced at the same time.

Item	Part Name	Qty	Replacement frequency
Fuel pre-filter	Cartridge (incl. O-ring)	1	Every 500 hours
Engine oil filter	Cartridge	1	Every 500 hours
Hydraulic tank vent	Element	1	Every 500 hours
Fuel main filter	Cartridge	1	Every 1000 hours
Hydraulic oil filter	Element (O-ring)	1 (1)	Every 1000 hours
Corrosion resistor (if equipped)	Cartridge	1	Every 1000 hours
Additional vent for hydraulic tank	Element	1	Every 1000 hours
Air conditioner RECIRC filter	Filter	1	Every one year
Air conditioner FRESH filter	Element	1	Every one year
Air cleaner	Element assembly	1	—
Additional filter for breaker (if equipped)	Element (O-ring)	1 (1)	—
	(O-ring)	(1)	
Bucket	Vertical pin type Tooth (Pin) (Lock)	5 (5) (5)	—
	Horizontal pin type Tooth (Pin)	5 (5) (5)	
	Side cutter type Cutter (left) Cutter (right)	1 1	
	Shroud type Shroud Pin	2 (4)	
	Ripper bucket Tooth Pin	5 5	

MAINTENANCE PROCEDURE

INITIAL 1000 HOURS MAINTENANCE (ONLY AFTER THE FIRST 1000 HOURS)

Carry out the following maintenance only after the first 1000 hours of operation on new machines.

- Check engine valve clearance, adjust

Special tools are needed for inspection and maintenance, so contact your Komatsu distributor. For details of the method of replacing or maintaining, see the section on EVERY 2000 HOURS SERVICE.

CHECK AND ADJUST TRACK TENSION

! WARNING

For details of starting the engine and operating the work equipment, see “STARTING THE ENGINE” on page 2-86, “WARMING UP ENGINE” on page 2-89, and “WORK EQUIPMENT OVERVIEW” on page 2-115.

The wear of the pins and bushings on the undercarriage will vary with the working conditions and type of soil, so inspect the track tension frequently in order to maintain the standard tension.

Stop the machine on firm, horizontal ground when carrying out the inspection and maintenance.

CHECKING

1. Run the engine at low idle, move the machine forward a distance equal to the length of track on the ground, then stop the machine.
2. Choose wooden block (3) that will reach from idler (1) to carrier roller (2), then place it on top of the track.
3. Measure the maximum deflection between the top surface of the track and the bottom surface of the wooden block.
Standard deflection $a = 10$ to 30 mm (0.4 to 1.2 in).

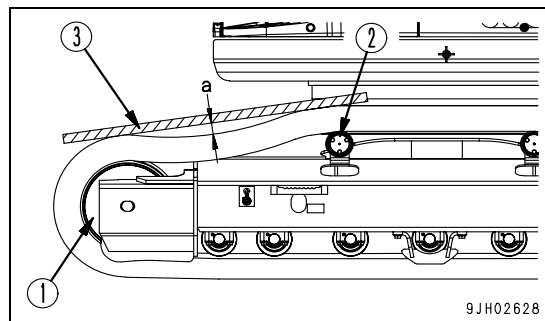

- If the track tension is not at the standard value, adjust it in the following manner.

ADJUSTMENT

! WARNING

There is danger of plug (1) flying out under the high internal pressure of the grease. Never loosen plug (1) more than one turn.

Never loosen any part other than plug (1). Never put your face in the mounting direction of plug (1).

If the track tension cannot be loosened with the procedure given here, please contact your Komatsu distributor.

★ **Increasing Track Tension**

1. Prepare a grease pump.

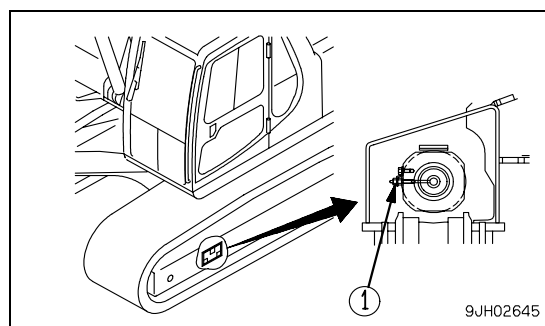

CLEANING CAB FLOOR

! WARNING

When setting the machine at an angle, use strong blocks to stabilize the machine and be extremely careful when doing this.

If the control levers are touched by mistake, the work equipment or machine may suddenly move, and this may lead to a serious accident. Set the safety lock lever securely to the LOCK position before getting up from the operator's seat.

- When cleaning the floor, be careful not to get water on the monitor and connectors inside the operator's cab.
- Never spray water above the pedestal of the operator's seat (2).

With the washable floor, it is possible to flush out the dirt on the cab floor directly with water.

Washing

1. Set the machine at an angle.
2. Swing the upper structure slowly so that the water drain holes (3) in the cab floor are at a low position.

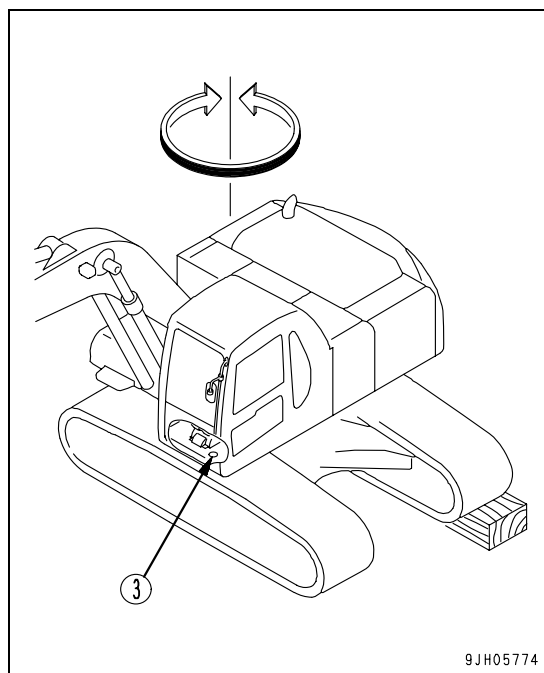

3. Lower the work equipment to the ground and set the machine in a stable condition.

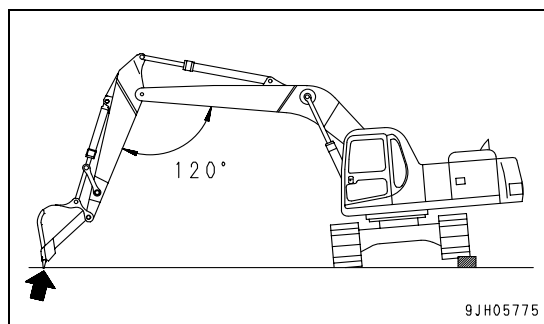

Remark

If distilled water is added to above the UPPER LEVEL (U.L.) line, use a syringe to lower the level to the UPPER LEVEL (U.L.) line.

Neutralize the removed fluid with baking soda (sodium bicarbonate), then flush it away with a large amount of water or consult your Komatsu distributor or battery maker.

WHEN IT IS IMPOSSIBLE TO CHECK ELECTROLYTE LEVEL FROM SIDE OF BATTERY

If it is impossible to check the electrolyte level from the side of the battery, or there is no display of the UPPER LEVEL line on the side of the battery, check as follows.

1. Remove cap (2) at the top of the battery, look through the water filler port (3), and check the electrolyte surface. If the electrolyte does not reach the sleeve (4), add distilled water so that the level reaches the bottom of the sleeve (UPPER LEVEL line) without fail.
 - A. Suitable level: Electrolyte level is up to bottom of sleeve, so surface tension causes electrolyte surface to bulge and poles appear bent.
 - B. Low: Electrolyte level is not up to bottom of sleeve, so poles appear straight and not bent.
2. After adding distilled water, tighten cap (2) securely.

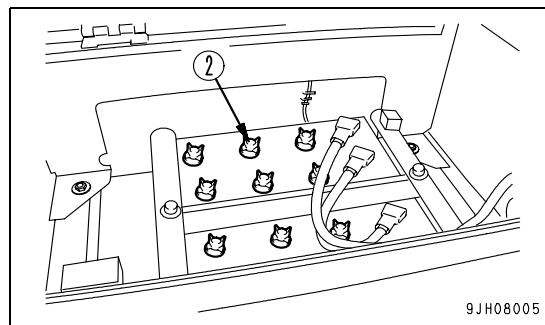

Remark

If distilled water is added to above the bottom of the sleeve, use a syringe to lower the level to the bottom of the sleeve. Neutralize the removed fluid with baking soda (sodium bicarbonate), then flush it away with a large amount of water or consult your Komatsu distributor or battery maker.

- When it is Possible to Use Indicator to Check Electrolyte Level
- If it is possible to use an indicator to check the electrolyte level, follow the instructions given.

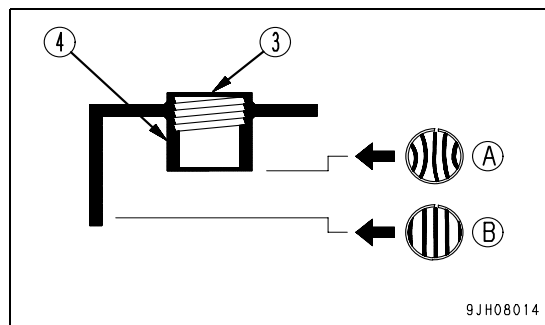

CLEAN AIR CONDITIONER FRESH/RECIRC FILTERS

⚠ WARNING

If compressed air is used, there is danger that dirt may fly and cause personal injury.

Always wear protective glasses, dust mask, and other protective equipment.

- As a guideline, the filters should be cleaned every 500 hours, but on dusty jobsites, clean the filters more frequently.

Remark

If the filter becomes clogged, the air flow will be reduced, and there will be an abnormal noise from the air conditioner unit.

CLEANING RECULATING AIR FILTER

- Remove wing bolts (1) from the inspection window at the bottom rear left on the inside of the operator's cab, then take out the recirculated air filter.
- Clean the filter with compressed air. If there is oil on the filter, or if the filter is extremely dirty, wash it in a neutral agent. After rinsing it in water, dry it thoroughly before using it again.

Replace the filter with a new part every year. If the clogging of the filter cannot be removed by blowing with air or washing in water, replace the filter immediately.

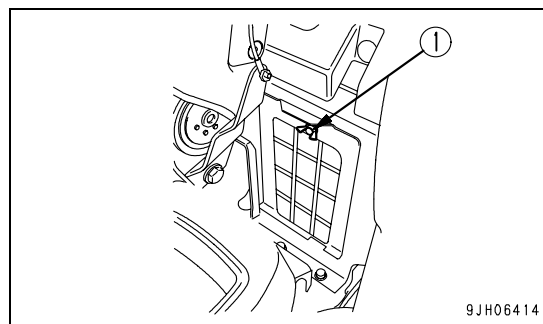

CLEANING FRESH AIR FILTER

- Use the ignition switch key to open cover (2) at the rear left of the operator's cab, then open cover (2) by hand and remove filter (3) inside the cover.
- Clean the filter with compressed air. If there is oil on the filter, or if the filter is extremely dirty, wash it in a neutral agent. After rinsing it in water, dry it thoroughly before using it again.

Replace the filter with a new part every year. If the clogging of the filter cannot be removed by blowing with air or washing in water, replace the filter immediately.

- After cleaning, return filter (3) to its original position and close the cover. Use the ignition switch key to lock the cover. Do not forget to remove the ignition switch key.

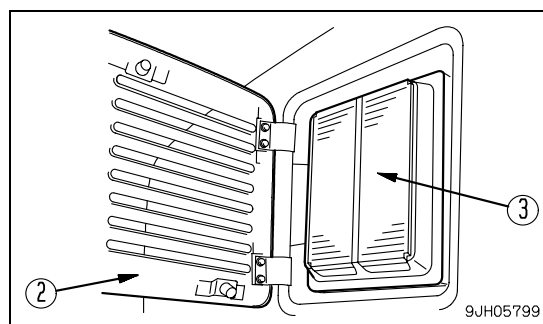

Remark

The **FRESH** filter must be installed facing in the correct direction.

When installing, insert the long (L) end of filter (3) into the filter case first. If the short (S) end is installed first, cover (2) will not close.

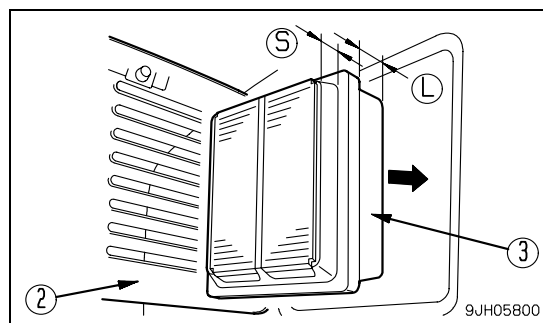

CLEAN HYDRAULIC TANK STRAINER

! WARNING

The parts and oil are at high temperature immediately after the engine is stopped, and may cause burns. Wait for the temperature to go down before starting the work.

When removing the oil filler cap, turn it slowly to release the internal pressure, then remove it.

1. Remove the cap from oil filler (F), and release the internal pressure.
2. Loosen 6 bolts, then remove cover (1). When doing this, the cover may fly out under the force of spring (2), so push the cover down when removing the bolts.
3. Hold the top of rod (3) and pull up to remove spring (2) and strainer (4).
4. Remove any dirt stuck to strainer (4), then wash it in clean diesel oil or flushing oil. If strainer (4) is damaged, replace it with a new part.
5. When installing, insert strainer (4) into protruding part (5) of the tank, and assemble.
6. Assemble so that the protruding part at the bottom of cover (1) holds spring (2), then tighten with the bolt.

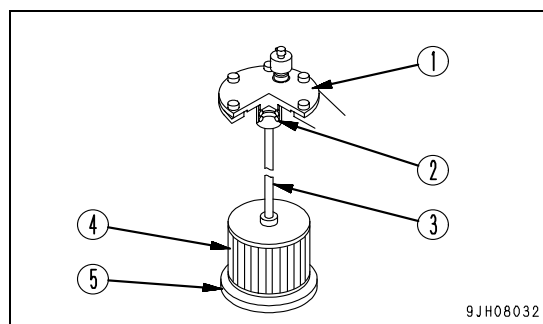
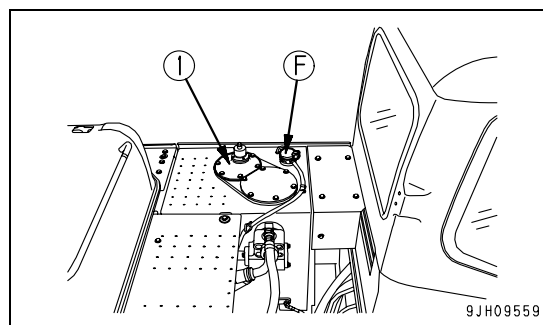

MAINTENANCE SCHEDULE	3-16
MAINTENANCE SCHEDULE CHART	3-16
MAINTENANCE INTERVAL FOR HYDRAULIC BREAKER	3-18
REPLACE HYDRAULIC FILTER ELEMENT	3-18
CHANGE OIL IN HYDRAULIC TANK	3-18
REPLACING ADDITIONAL FILTER ELEMENT FOR BREAKER (IF EQUIPPED)	3-18
MAINTENANCE PROCEDURE	3-19
INITIAL 1000 HOURS MAINTENANCE (ONLY AFTER THE FIRST 1000 HOURS)	3-19
WHEN REQUIRED	3-20
CHECK, CLEAN AND REPLACE AIR CLEANER ELEMENT	3-20
CLEAN INSIDE OF COOLING SYSTEM	3-25
CHECK AND TIGHTEN TRACK SHOE BOLTS	3-28
CHECK AND ADJUST TRACK TENSION	3-29
REPLACE BUCKET TEETH (VERTICAL PIN TYPE)	3-31
REPLACE BUCKET TEETH (HORIZONTAL PIN TYPE)	3-34
REPLACE BUCKET SIDE CUTTER, SHROUD	3-35
ADJUST BUCKET CLEARANCE	3-36
CHECK WINDOW WASHER FLUID LEVEL, ADD FLUID	3-37
CHECK AND ADJUST AIR CONDITIONER	3-38
CLEANING CAB FLOOR	3-39
SETTING MACHINE AT AN ANGLE	3-41
BLEEDING AIR FROM HYDRAULIC SYSTEM	3-42
CHECK BEFORE STARTING	3-44
EVERY 50 HOURS MAINTENANCE	3-45
LUBRICATING	3-45
EVERY 250 HOURS MAINTENANCE	3-46
LUBRICATE SWING CIRCLE	3-46
CHECK OIL LEVEL IN MACHINERY CASE, ADD OIL	3-46
CHECK OIL LEVEL IN FINAL DRIVE CASE, ADD OIL	3-47
CHECK LEVEL OF BATTERY ELECTROLYTE	3-48
CHECK, ADJUST TENSION OF AIR CONDITIONER COMPRESSOR BELT	3-50
EVERY 500 HOURS MAINTENANCE	3-51
LUBRICATING	3-51
REPLACE FUEL PRE-FILTER CARTRIDGE	3-52
CHECK SWING PINION GREASE LEVEL, ADD GREASE	3-55
CHANGING ENGINE OIL AND REPLACING ENGINE OIL FILTER CARTRIDGE ...	3-56
CLEAN/INSPECT RADIATOR, OIL COOLER, AFTERCOOLER AND CONDENSER FINS	
3-57	
CLEAN AIR CONDITIONER FRESH/RECIRC FILTERS	3-59
REPLACE VENT ELEMENT IN HYDRAULIC TANK	3-60
EVERY 1000 HOURS MAINTENANCE	3-61
REPLACE FUEL MAIN FILTER CARTRIDGE	3-61
REPLACE HYDRAULIC OIL FILTER ELEMENT	3-63
CHANGE OIL IN SWING MACHINERY CASE	3-64
CHECK OIL LEVEL IN DAMPER CASE, ADD OIL	3-65
CHECK ALL TIGHTENING POINTS OF ENGINE EXHAUST PIPE CLAMPS	3-65
REPLACE CORROSION RESISTOR CARTRIDGE (IF EQUIPPED)	3-66
CHECK FAN BELT AND ALTERNATOR DRIVE BELT TENSION, REPLACE	3-66
REPLACE HYDRAULIC TANK ADDITIONAL VENT ELEMENT	3-67

MACHINES READY FOR ATTACHMENTS

EXPLANATION OF COMPONENTS

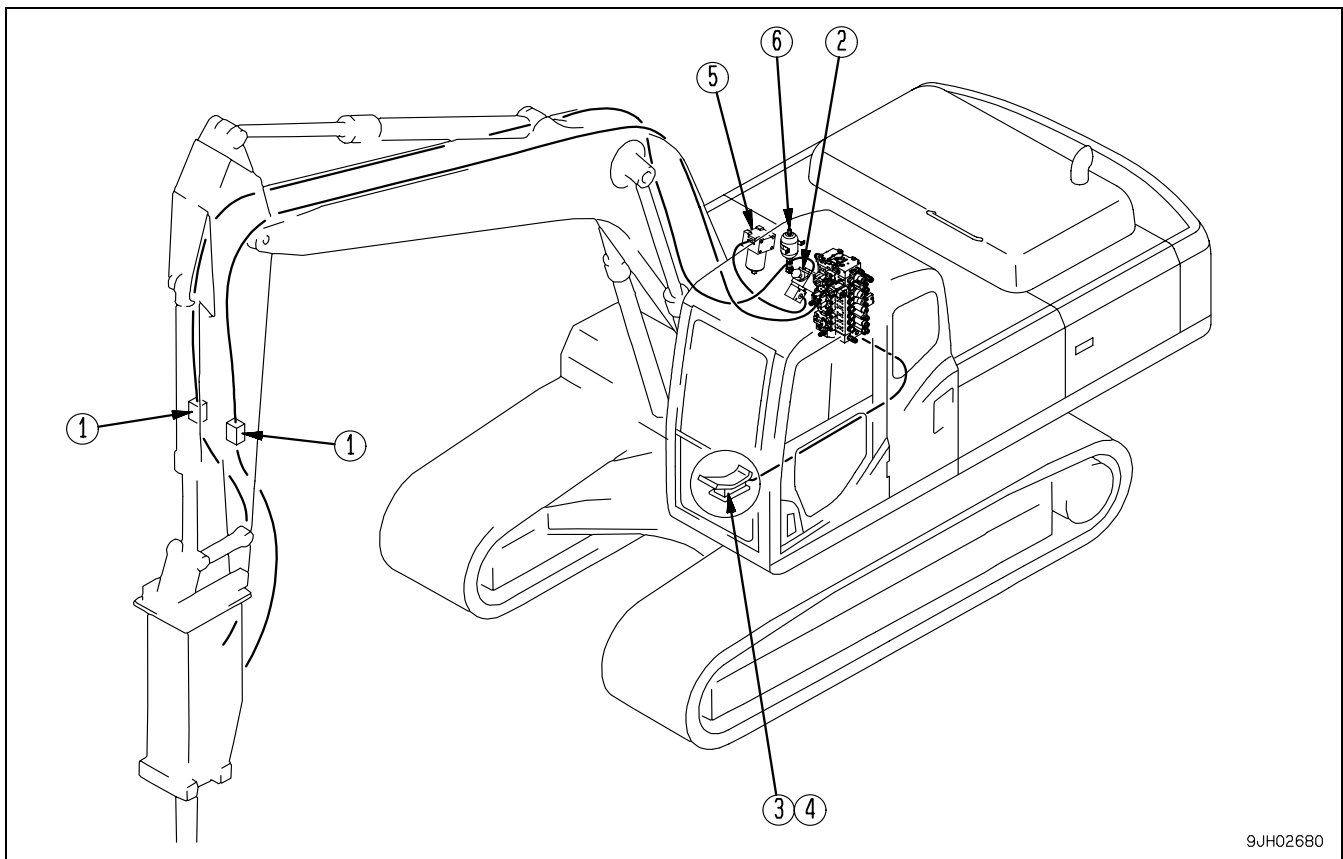

- | | |
|-----------------------------|----------------------------------|
| 1. Stop valve | 4. Lock pin |
| 2. Selector valve | 5. Additional filter for breaker |
| 3. Attachment control pedal | 6. Accumulator |

STOP VALVE

This valve (1) stops the flow of the hydraulic oil.

- (a) **FREE:** Hydraulic oil flows
- (b) **LOCK:** Hydraulic oil stops

Set this valve to the **LOCK** position when removing or installing attachments.

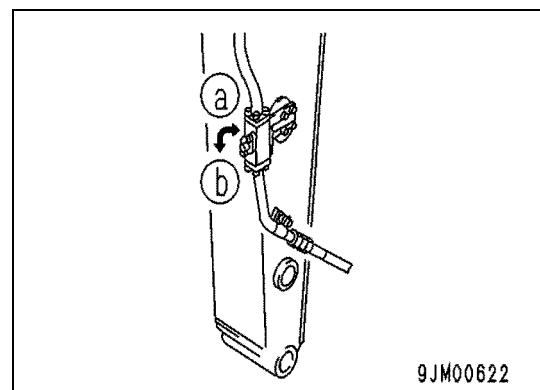

ATTACHMENT OPERATIONS

⚠ WARNING

- Do not rest the foot on the pedal and depress it, when the auto deceleration switch is in ON position. The engine speed rises all of sudden and the attachment will move suddenly and cause serious damage or injury.
- Do not put your foot on the pedal except when operating the pedal. If rest your foot is the pedal during operations, and it is depressed by accident, the attachment may move suddenly and cause serious damage or injury.

Operate the attachment as follows.

WHEN USING BREAKER

With the working mode set to B mode, set the lock pin to FREE position (b) for the front only, and depress the front of the pedal to actuate the breaker.

1. Set the working mode to B mode.

PRECAUTIONS WHEN USING

- Check that the stop valve is at the FREE position.
- Check that the working mode is B mode.
- When considering whether it is necessary to install an accumulator for the attachment circuit, contact the attachment manufacturer and then decide.
- For other precautions when handling the breaker, follow the instruction manual from the breaker manufacturer and use the breaker correctly.
- The deterioration of the hydraulic oil when using the breaker is much faster than for normal operations, so reduce the maintenance interval for the hydraulic oil and element.

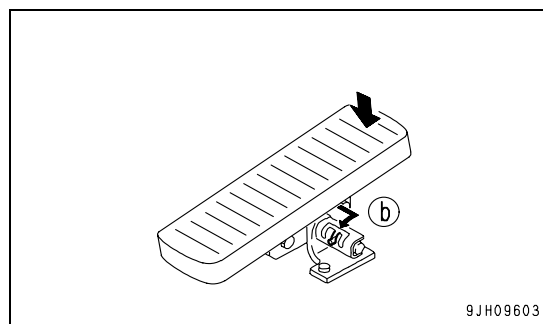

WHEN USING GENERAL ATTACHMENT SUCH AS CRUSHER

With the working mode set to P mode or E mode, set the lock pin to FREE position (c) for both the front and rear, and depress the front or rear of the pedal to actuate the attachment.

1. Set the working mode to P mode or E mode.
2. If it is necessary to adjust the oil flow, see "Setting Oil Flow (PAGE 2-29)".

PRECAUTIONS WHEN USING

- Check that the stop valve is at the FREE position.
- Check that the working mode is P mode or E mode.
- For other precautions related to the handling of attachment, follow the explanation in the operation manual provided by the attachment manufacturer to operate the attachment correctly.

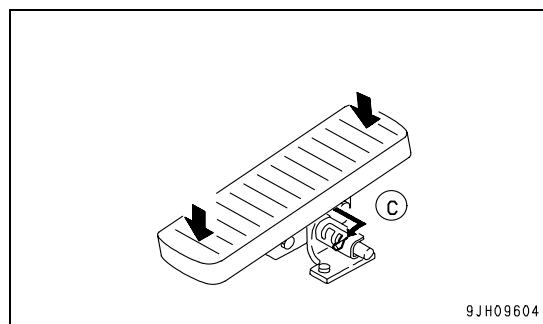

CLICK HERE TO **DOWNLOAD** THE COMPLETE MANUAL

- Thank you very much for reading the preview of the manual.
- You can download the complete manual from: www.heydownloads.com by clicking the link below



- Please note: If there is no response to CLICKING the link, please download this PDF first and then click on it.

CLICK HERE TO **DOWNLOAD** THE COMPLETE MANUAL