

# Operation & Maintenance Manual

---

---

---

## PC160-6K PC180LC-6K PC180NLC-6K PC200EN-6K PC200EL-6K HYDRAULIC EXCAVATOR

	PC160-6K	- K30001	
SERIAL NUMBERS	PC180LC-6K	- K30001	AND UP
	PC180NLC-6K	- K30001	
	PC200EN-6K	- K30001	
	PC200EL-6K	- K30001	



### — WARNING —

Unsafe use of this machine may cause serious injury or death. Operators and maintenance personnel must read this manual before operating or maintaining this machine. This manual should be kept inside the cab for reference and periodically reviewed by all personnel who will come into contact with the machine.

# KOMATSU

CLICK HERE TO **DOWNLOAD** THE COMPLETE MANUAL

- Thank you very much for reading the preview of the manual.
- You can download the complete manual from: [www.heydownloads.com](http://www.heydownloads.com) by clicking the link below



- Please note: If there is no response to CLICKING the link, please download this PDF first and then click on it.

CLICK HERE TO **DOWNLOAD** THE COMPLETE MANUAL

12. Operation	
12.1 Check before starting engine .....	2-38
12.2 Starting engine .....	2-48
12.3 Operations and checks after starting engine .....	2-51
12.4 Moving machine off .....	2-57
12.5 Steering machine .....	2-60
12.6 Stopping machine .....	2-62
12.7 Swinging .....	2-63
12.8 Operation of work equipment .....	2-64
12.9 Working mode selection .....	2-65
12.10 Prohibitions for operation .....	2-67
12.11 Precaution for operation .....	2-69
12.12 Precaution when travelling up or down hills .....	2-70
12.13 How to escape from mud .....	2-72
12.14 Work possible using hydraulic excavator .....	2-73
12.15 Replacement and inversion of bucket .....	2-74
12.16 Parking the machine .....	2-76
12.17 Check after finishing work .....	2-77
12.18 Stopping engine .....	2-78
12.19 Check after stopping engine .....	2-79
12.20 Locking .....	2-79
12.21 Overload warning device .....	2-79
13 Transportation	
13.1 Loading, unloading work .....	2-80
13.2 Precautions for loading .....	2-82
13.3 Precautions for transportation .....	2-83
13.4 Lifting the machine .....	2-83
14. Cold weather operation	
14.1 Precaution for low temperature .....	2-85
14.2 Precautions after completion of work .....	2-86
14.3 After cold weather .....	2-86
15. Long-term storage	
15.1 Before storage .....	2-87
15.2 During storage .....	2-88
15.3 After storage .....	2-88
15.4 Starting machine after long-term storage .....	2-88
16. Troubleshooting	
16.1 Phenomena that are not failures .....	2-89
16.2 Method of towing machine .....	2-89
16.3 Using method for light-weight towing hole .....	2-89
16.4 Precautions on particular jobsites .....	2-90
16.5 If battery is discharged .....	2-90
16.6 Other trouble .....	2-94

**⚠ WARNING:** Failure to follow these safety precautions may lead to a serious accident.

### PRECAUTIONS FOR ATTACHMENTS

- When installing and using an optional attachment, read the instruction manual for the attachment and the information related to attachments in this manual.
- Do not use attachments that are not authorised by Komatsu or your Komatsu distributor. Use of unauthorised attachments could create a safety problem and adversely affect the proper operation and useful life of the machine.
- Any injuries, accidents, product failures resulting from the use of unauthorised attachments will not be the responsibility of Komatsu.

### MACHINES WITH ACCUMULATOR

On machines equipped with an accumulator, for a short time after the engine is stopped, the work equipment will lower under its own weight when the work equipment control lever is shifted to LOWER. After the engine is stopped, set the safety lock lever to the lock position (and also lock the attachment pedal with the lock pin).

When releasing the pressure inside the work equipment circuit on machines equipped with an accumulator, follow the procedure given in the inspection and maintenance section.

**Method of releasing pressure → See 11.18 “HANDLING THE ACCUMULATOR”.**

The accumulator is filled with high-pressure nitrogen gas, and it is extremely dangerous if it is handled in the wrong way. Always observe the following precautions.

- Never make any hole in the accumulator or expose it to flame or fire.
- Do not weld anything to the accumulator.
- When carrying out disassembly or maintenance of the accumulator, or when disposing of the accumulator, it is necessary to release the gas from the accumulator. A special air bleed valve is necessary for this operation, so please contact your Komatsu distributor.

**Gas in accumulator → See 11.18 “HANDLING THE ACCUMULATOR”.**

### EMERGENCY EXIT

- When exit by normal means is prevented in an emergency you can get out through the emergency exit (rear window).
- Pull the ring at the bottom of the window and remove strip. This will allow you to push out glass.

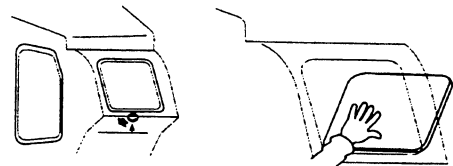

### ROTATING BEACON (OPTION)

- When the machine is operated on or beside a road, a rotating beacon is required to avoid a traffic accident.
- Contact your Komatsu distributor to install beacon lamp.

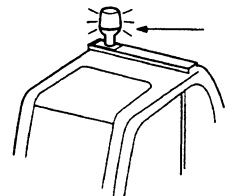

### ELECTROMAGNETIC INTERFERENCE

When this machine is operating close to a source of high electromagnetic interference, such as a radar station, some abnormal phenomena may be observed.

- The display on the monitor panel may behave erratically.
- The warning buzzer may sound.

These effects do not signify a malfunction and the machine will return to normal as soon as the source of interference is removed.

## 7.5 TOWING

### WHEN TOWING, ATTACH WIRE TO FRAME

- Injury or death could result if a disabled machine is towed incorrectly.
- If your machine is towed by another machine, ALWAYS use a wire rope with a sufficient towing capacity.
- NEVER allow a disabled machine to be towed on a slope.
- Do not use a chinked or frayed wire rope.
- Do not straddle the towing cable or wire rope.
- When connecting up a towing machine, do not let anyone enter the area between the towing machine and the equipment being towed.
- Set the towing machine and the towing connection of the equipment being towed in a straight line when connecting it.
- Place pieces of wood between the wire ropes and body to protect them from wear or damage.
- Never tow the machine using the light-duty towing hole.

**Towing method → See 16.2 “METHOD OF TOWING MACHINE.”**

**CORRECT**

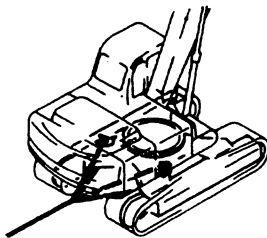

F 19584

**INCORRECT**

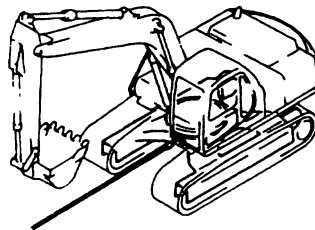

F 19585

**⚠** **WARNING:** For reasons of safety,  
always follow these safety precautions.

### WASTE MATERIALS

- Never dump waste oil in a sewer system, rivers, etc.
- Always put oil drained from your machine in containers. Never drain oil directly on the ground.
- Obey appropriate laws and regulations when disposing of harmful objects such as oil, fuel, coolant, solvent, filters, batteries, and others.

**INCORRECT**

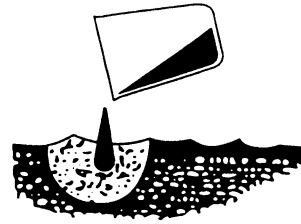

**B. CAUTION ITEMS (11.1.2)****CAUTION**

**If these monitor items flash, check and repair the appropriate location as soon as possible.**

These are items which need to be observed while the engine is running. If any abnormality occurs, items which need to be repaired as soon as possible are displayed.

If there is any abnormality, the appropriate monitor lamp will flash to indicate the location of the abnormality.

**C. EMERGENCY STOP ITEMS (11.1.3)****CAUTION**

**If these monitors items flash, stop operations immediately, then check and repair the appropriate location.**

These are items which need to be observed while the engine is running. If any abnormality occurs, items which need to be repaired immediately are displayed.

If there is any abnormality, the appropriate monitor lamp will flash to indicate the location of the abnormality and the buzzer will sound.

**D. METER DISPLAY PORTION (11.1.4)**

This portion consists of pre-heating monitor, swing lock monitor, engine water temperature gauge, fuel gauge and display.

**E. SWITCHES (11.1.5)**

The switches are used for setting clock time and for selecting working mode and travel speed.

## 11.2 SWITCHES

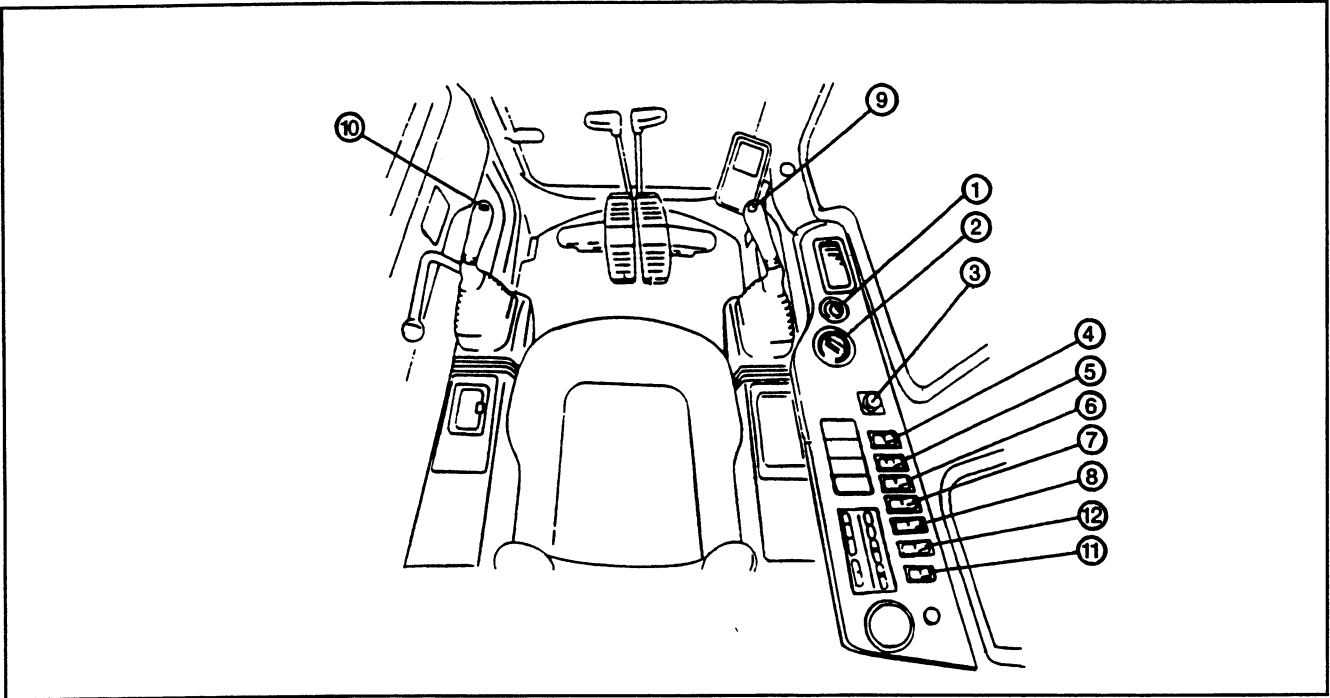

### 1. STARTING SWITCH

This switch is used to start or stop the engine.

#### OFF position

The key can be inserted or withdrawn. Except for the cab lamp, radio (if fitted) and clock, the switches for the electric system are all turned off and the engine is stopped.

#### ON position

Electric current flows in the charging and lamp circuits.

Keep the starting switch key at the ON position while the engine is running.

#### START position

This is the engine-start position. Keep the key at this position during cranking. Immediately after starting the engine, release the key which will automatically return to the ON position.

#### HEAT (preheat) position

When starting the engine in winter, set the key to this position. When the key is set to the HEAT position, the pre-heating monitor lights up. Keep the key at this position until the monitor lamp goes off. Immediately after the pre-heating monitor goes off, release the key. The key automatically returns to the OFF position. Then, start the engine by turning the key to the START position.

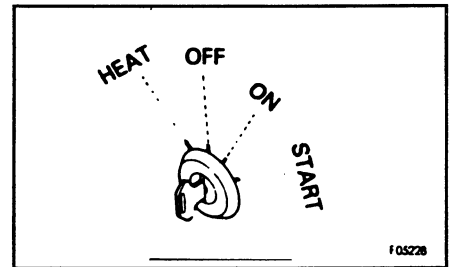

## 11.5 FRONT WINDOW

**⚠ WARNING**

When opening the front window, always hold grip firmly with both hands and pull up. If you use only one hand, your hand may slip and get caught.

It is possible to store (pull up) the front window (top) in the roof of the operator's compartment.

### When opening

**⚠ WARNING**

When the front window is open, there is danger that it will fall, so always lock it with left and right lock pins Ⓐ.

1. Place the work equipment on flat ground and stop the engine.
2. Securely lock the safety lock lever.

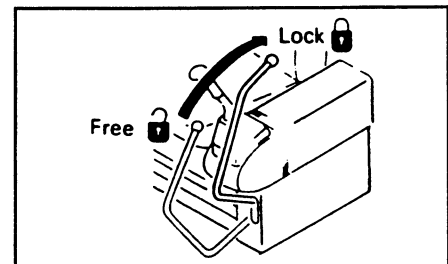
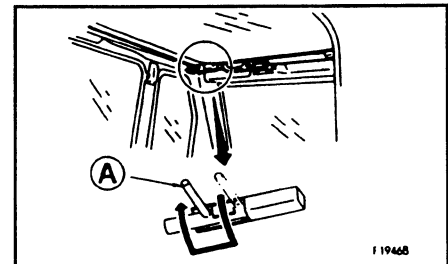

3. Confirm that the wiper is stored inside the right frame.

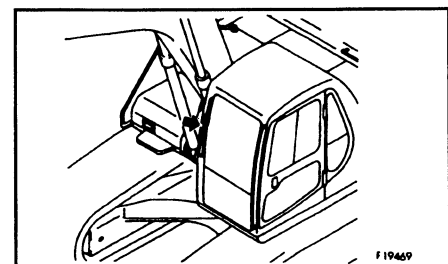

4. Pull lock pins Ⓐ at the top left and right sides of the front window to the inside to release the lock.

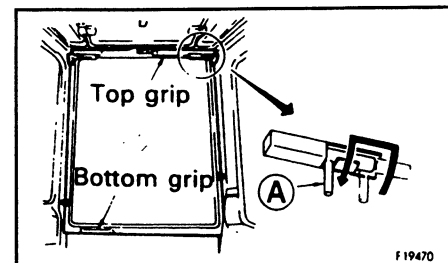

### 11.14 FUSIBLE LINK

If the starting motor will not rotate when the starting switch is turned ON, a possible cause is disconnection of wire-type fusible link ①. Open the battery room door on the left side of the machine body to inspect the fusible link and, if necessary, replace it.

**REMARK**

A fusible link refers to the large-sized fuse wiring installed in the high current flow portion of the circuit to protect electrical components and wiring from burning, similar to an ordinary fuse.

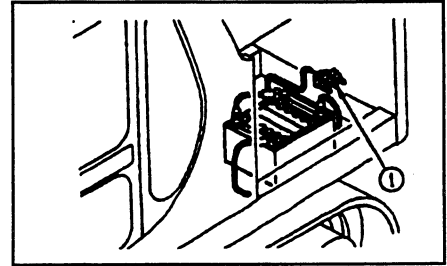

### 11.15 CONTROLLERS

A pump controller and governor controller are provided.

**NOTICE**

- Never splash or spill water, mud or drink over the controllers as this may cause a fault.
- If a fault occurs in the controller, do not attempt repair, but consult your Komatsu distributor.

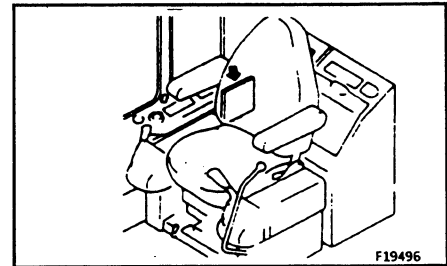

### 11.16 TOOL BOX

This is used for keeping the tools.

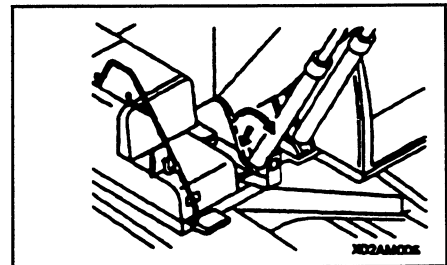

### 11.17 REFUELLING PUMP (Option)

**⚠ WARNING**

- Do not bring fire or sparks near the fuel.

1. When the machine is operated on sites with no fuel container and pump, the machine may be refuelled using the refuelling pump ① (if fitted) from fuel barrels.  
The refuelling pump is located in the toolbox at the front right hand side of the machine.
2. Place the fuel hose ②, which is stored in tray ③ into the fuel barrel placed next to the machine.
3. Switch on refuelling pump using switch ④ on the pump assembly when adding fuel, never let the fuel overflow. This may cause fires.

**Notes**

- This pump is protected by fuse ⑤. If pump fails to function check fuse (10A).
- Ensure strainer on hose end is clean.

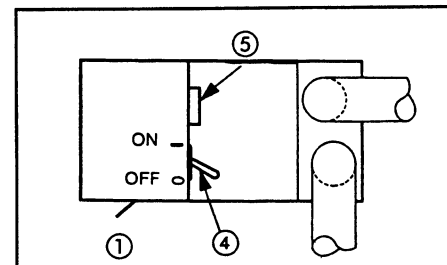
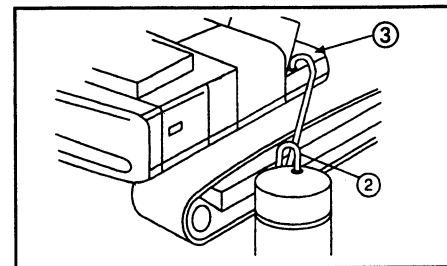

**(D) Armrest height adjustment**

Armrest ④ can be raised and lowered by loosening the bolts in the rear of the armrest columns, adjusting the height and retightening the bolts

**(E) Fore-and-aft adjustment of whole seat**

After lever ⑤ is pulled up and the seat is set to the desired position, release the lever. In this case the operator's seat, left and right levers and safety lock lever will slide together. Adjustable fore-and-aft movement: 120 mm (4.7 in)

**(F) Suspension adjustment**

When knob ⑥ is turned clockwise, the suspension becomes harder and when turned counterclockwise, softer. Adjust the dial so that the suspension best matching the operator's weight is selected. Adjustable range: 50 to 120 kg (110 to 265 lb)

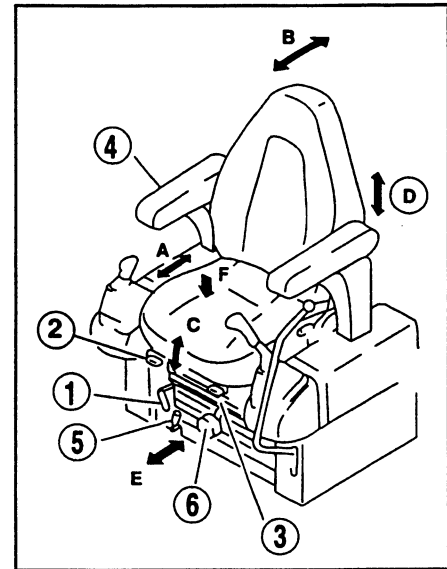
**ADJUSTMENT OF MONITOR PANEL ANGLE**

Turn the monitor panel so that the operator can view the monitor with ease. When adjusting the angle, the panel should be set to the desired position using both hands. The panel is automatically locked at that position.

Amount of adjustment: 30° (stepless)

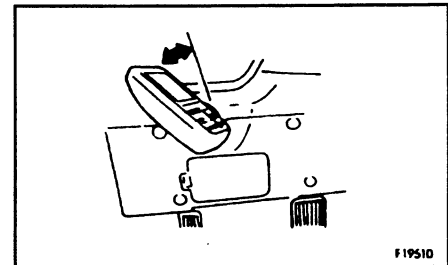

7. Turn fuel control dial ① to the full speed (MAX) position and carry out the operation in Step 6 for 3 - 5 minutes.
8. Repeat the following operation 3 - 5 times and operate slowly.
  - Boom operation      RAISE      ↔ LOWER
  - Arm operation        IN            ↔ OUT
  - Bucket operation    CURL        ↔ DUMP
  - Swing operation     LEFT        ↔ RIGHT
  - Travel (Lo) operation FORWARD ↔ REVERSE

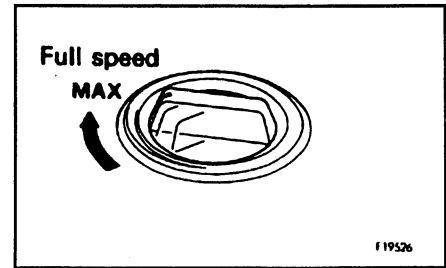

#### REMARK

If the above operation is not carried out, there may be a delay in response when starting or stopping each actuator, so continue the operation until it becomes normal.

9. Use working mode switch ② on the monitor panel to switch to the working mode to be used.

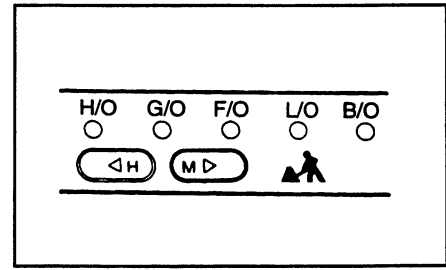

## 12.9 WORKING MODE SELECTION

### WORKING MODE

The mode selector switches can be used to switch the mode to match the conditions and purpose of work, thereby enabling efficient operation.

Use the following procedures to make the most effective use of each mode.

When the starting switch is turned ON, the working mode is set to general operation mode (G.O.), so normal work can be carried out without needing to set the mode.

Set the most effective mode according to the type of work using working mode selector switch.

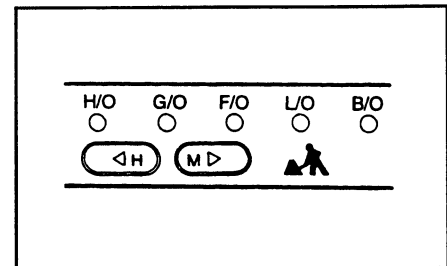

Working mode	Applicable work	Power max. (power up)	Swift slow-down (speed down)
		Power	Speed
Heavy-duty operation mode (H.O.)	Large amount of digging and loading in a short time	5% up	Approx 20% down
General operation mode (G.O.)	Normal digging and loading operation	10% up	Approx 10% down
Finishing operation mode (F.O.)	Finishing, levelling and general hauling operation	-	-
Lifting operation mode (L.O.)	Positioning, etc.	-	-
Breaker operation mode (B.O.)	Breaker operation	-	-

### NOTICE

**Never carry out breaker operation in heavy-duty operation mode (H.O.) as this may result in breakage of hydraulic equipment.**

### 12.15.2 INVERSION

1. Place the bucket in contact with a flat surface.

#### REMARK

When removing the pins, place the bucket so that it is in light contact with the ground.

If the bucket is lowered strongly to the ground, the resistance will be increased and it will be difficult to remove the pins.

2. Remove the stopper bolts and nuts, then remove pins ① and ②, and remove the bucket.

#### NOTICE

After removing the pins, make sure that they do not become contaminated with sand or mud and that the seals of bushing on both sides do not become damaged.

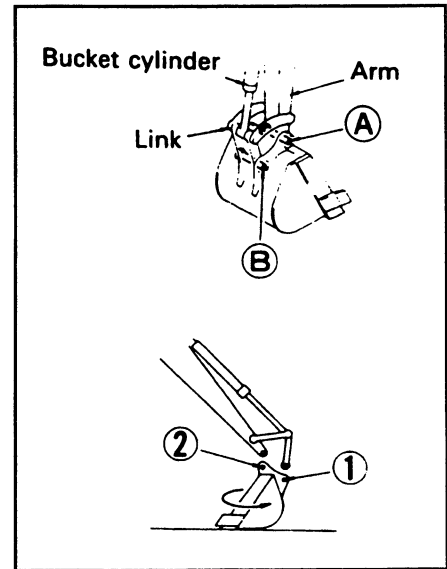

3. Install the bucket inversely.  
After the bucket is inverted, correct the inclination and direction of the retaining pin holes ① and ② and stabilise the bucket securely.
4. Align the arm with holes ① and the link with holes ②, then coat with grease and install pins ① and ②.

#### REMARK

Install the O-rings into retaining hole ① of the arm and bucket.

When installing the bucket, the O-rings are easily damaged, so fit the O-rings on the boss of the arm end as shown in the diagram.

When knocking the pin, move the O-ring down to the regular groove.

5. Install the stopper bolts and nuts for each pin, then grease the pin.

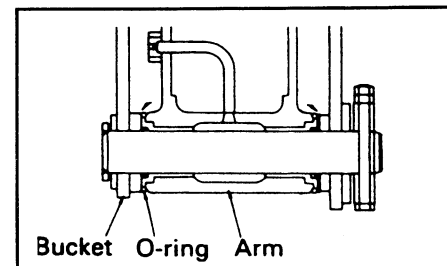
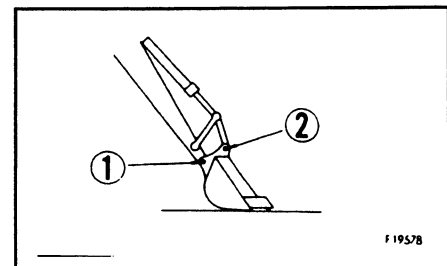

CLICK HERE TO **DOWNLOAD** THE COMPLETE MANUAL

- Thank you very much for reading the preview of the manual.
- You can download the complete manual from: [www.heydownloads.com](http://www.heydownloads.com) by clicking the link below



- Please note: If there is no response to CLICKING the link, please download this PDF first and then click on it.

CLICK HERE TO **DOWNLOAD** THE COMPLETE MANUAL

# 14. COLD WEATHER OPERATION

## 14.1 PRECAUTIONS FOR LOW TEMPERATURE

If the temperature becomes low, it becomes difficult to start the engine, and the coolant may freeze, so do as follows.

### 14.1.1 FUEL AND LUBRICANTS

Change to fuel and oil with low viscosity for all components. For details of the specified viscosity, see 20. "USE OF FUEL, COOLANT AND LUBRICANTS ACCORDING TO AMBIENT TEMPERATURE".

### 14.1.2 COOLANT



**WARNING**

Keep antifreeze fluid away from an open flame. Never smoke when using antifreeze.

#### NOTICE

- Never use methanol, ethanol or propanol based antifreeze.
- Absolutely avoid using any water leak preventing agent irrespective of whether it is used independently or mixed with an antifreeze.
- Do not mix one antifreeze with a different brand.

For details of the antifreeze mixture when changing the coolant, see "24.2 WHEN REQUIRED".

Use a Permanent Antifreeze (ethylene glycol mixed with corrosion inhibitor, antifoam agent, etc.) meeting the standard requirements as shown below. With permanent antifreeze, no change of coolant is required for a year. If it is doubtful that an available antifreeze meets the standard requirements, ask the supplier of that antifreeze for information.

Standard requirements for permanent antifreeze

- SAE ..... J1034
- FEDERAL STANDARD ..... O-A-548D

#### REMARK

Where no permanent antifreeze is available, an ethylene glycol antifreeze without corrosion inhibitor may be used only for the cold season. In this case, clean the cooling system twice a year (in spring and autumn). When refilling the cooling system, add antifreeze in autumn, but do not add any in spring.

### 14.1.3 BATTERY



**WARNING**

- To avoid gas explosions, do not bring fire or sparks near the battery.
- Battery electrolyte is dangerous. If it gets in your eyes or on your skin, wash it off with large amounts of water, and consult a doctor.

When the ambient temperature drops, the capacity of the battery will also drop. If the battery charge ratio is low, the battery electrolyte may freeze. Maintain the battery charge as close as possible to 100%, and insulate it against cold temperature so that the machine can be started easily the next morning.

#### REMARK

Measure the specific gravity and calculate the rate of charge from the following conversion table.

Temp. of fluid Rate of charge	20°C (68°F)	0°C (32°F)	-10° (14°F)	-20° (-4°F)
	100%	1,28	1,29	1,30
90%	1,26	1,27	1,28	1,29
80%	1,24	1,25	1,26	1,27
75%	1,23	1,24	1,25	1,26

**16.6.2 CHASSIS**

- ( ): Always contact your Komatsu distributor when dealing with these items.
- In cases of abnormalities or causes which are not listed below, please contact your Komatsu distributor for repairs.

<b>Problem</b>	<b>Main causes</b>	<b>Remedy</b>
Speed of travel, swing, boom, arm, bucket is slow	<ul style="list-style-type: none"> <li>• Lack of hydraulic oil</li> </ul>	<ul style="list-style-type: none"> <li>• Add oil to specified level, see "CHECK BEFORE STARTING"</li> </ul>
Pump generates abnormal noise	<ul style="list-style-type: none"> <li>• Clogged element in hydraulic tank strainer</li> </ul>	<ul style="list-style-type: none"> <li>• Clean, see "EVERY 2000 HOURS SERVICE"</li> </ul>
Excessive rise in hydraulic oil temperature	<ul style="list-style-type: none"> <li>• Loose fan belt</li> <li>• Dirty oil cooler</li> <li>• Lack of hydraulic oil</li> </ul>	<ul style="list-style-type: none"> <li>• Adjust fan belt tension, see "EVERY 250 HOURS SERVICE"</li> <li>• Clean, see "EVERY 500 HOURS SERVICE"</li> <li>• Add oil to specified level, see "CHECK BEFORE STARTING"</li> </ul>
Track comes off	<ul style="list-style-type: none"> <li>• Track too loose</li> </ul>	<ul style="list-style-type: none"> <li>• Adjust track tension, see "WHEN REQUIRED"</li> </ul>
Abnormal wear of sprocket		
Bucket rises slowly, does not rise	<ul style="list-style-type: none"> <li>• Lack of hydraulic oil</li> </ul>	<ul style="list-style-type: none"> <li>• Add oil to specified level, see "CHECK BEFORE STARTING"</li> </ul>



## 21.2 TORQUE LIST



Unless otherwise specified, tighten the metric bolts and nuts to the torque shown in the table.

The tightening torque is determined by the width across the flats <b> of the nut and bolt.

If it is necessary to replace any nut or bolt, always use a Komatsu genuine part of the same size as the part that was replaced.

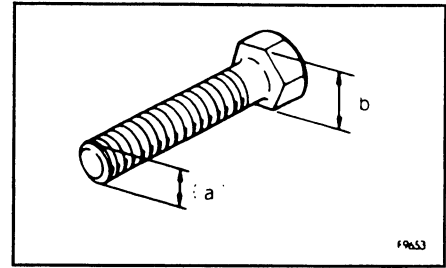
Nm (newton meter): 1 Nm  $\doteq$  0.1 kgm  
 $\doteq$  0.74 lbft



Thread diameter of bolt (mm) (a)	Width across flat (mm) (b)	 		
		Nm	kgm	lbft
6	10	13.2 ± 1.4	1.35 ± 0.15	9.73 ± 1.03
8	13	31.4 ± 2.9	3.2 ± 0.3	23.2 ± 2.1
10	16/17	65.7 ± 6.8	6.7 ± 0.7	48.5 ± 5.0
12	18/19	112 ± 9.8	11.5 ± 1.0	82.6 ± 7.2
14	21/22	177 ± 19	18.0 ± 2.0	131 ± 14
16	24	279 ± 29	28.5 ± 3	206 ± 21
18	27	383 ± 39	39 ± 3	282 ± 29
20	30	549 ± 58	56 ± 6	405 ± 43
22	32/34	745 ± 78	76 ± 8	549 ± 58
24	36	927 ± 98	94.5 ± 10	684 ± 72
27	41	1320 ± 140	135 ± 15	973 ± 100
30	46	1720 ± 190	175 ± 20	1270 ± 140
33	50	2210 ± 240	225 ± 25	1630 ± 180
36	55	2750 ± 290	280 ± 30	2030 ± 210
39	60	3280 ± 340	335 ± 35	2420 ± 250

### NOTICE

When tightening panels or other parts having tightening fixtures made of plastic, be careful not to use excessive tightening torque: doing so will damage the plastic parts.

- When deciding the ratio of antifreeze to water, check the lowest temperature in the past, and decide from the mixing rate table given below.  
It is actually better to estimate a temperature about 10°C lower when deciding the mixing rate.

**Mixing rat of water and antifreeze  
(For PC160, PC180)**

Min. atmospheric temperature	°C	-5	-10	-15	-20	-25	-30
	°F	23	14	5	-4	-13	-22
Amount of antifreeze	ℓ	4.6	6.0	7.2	8.2	9.2	9.95
Amount of water	ℓ	15.4	14.0	12.8	11.8	10.8	10.05

**(For PC200)**

Min. atmospheric temperature	°C	-5	-10	-15	-20	-25	-30
	°F	23	14	5	-4	-13	-22
Amount of antifreeze	ℓ	5.8	7.6	9.1	10.3	11.6	12.6
Amount of water	ℓ	19.3	17.5	16.0	14.8	13.5	12.5

**⚠ WARNING**

**Antifreeze is flammable, so keep it away from any flame.**

- Use city water for the cooling water.  
If river water, well water or other such water supply must be used, contact your Komatsu distributor.
- We recommend use of an antifreeze density gauge to control the mixing proportions.

**⚠ WARNING**

**When removing drain plug, avoid pouring coolant on yourself.**

### 24.1.18 REMOVAL OF BUCKET TEETH (ESCO VERTALOK® TYPE)

Replace the point before the adapter starts to wear.

#### WARNING

It is dangerous if the work equipment moves by mistake when the teeth are being replaced.  
Set the work equipment in a stable conditions, then stop the engine and apply the safety lock lever securely.

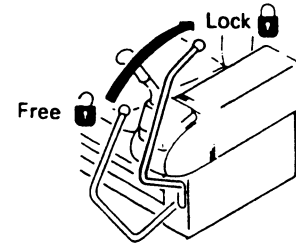

- Place a block under the bottom of the bucket to allow the pin to be knocked out with a hammer. Carry out full stroke operation of the control levers within 15 seconds after stopping the engine. After confirming that the work equipment is in a stable condition, lock the safety lock lever.  
Set so that the bottom face of the bucket is horizontal.

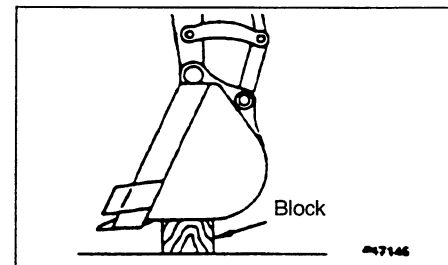

#### WARNING

- When installing Vertalok® teeth, always work safely and use proper equipment to avoid injury. Wear OSHA-approved hard hat, safety glasses, gloves, and steeltoed shoes. Be sure other people are out of the way; only one person is needed to install Vertalok® points.
- All struck tools or punches should have a bevel or radius around the striking face that is equal to 1/10th the width of the striking face.
- The rubber plug should be removed prior to any heating or welding near the Vertalok® nose or adapter.

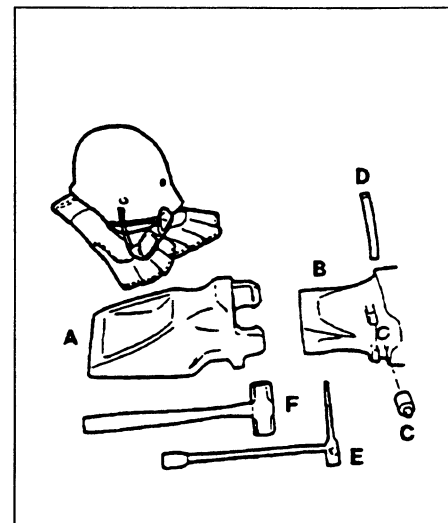

## 24.2.4 CHECK OIL LEVEL IN HYDRAULIC TANK, ADD OIL

### WARNING

- When removing the oil filler cap, oil may spurt out, so turn the cap slowly to release the internal pressure before removing the cap.
- If oil has been added to above the H mark, stop the engine and wait for the hydraulic oil to cool down, then drain the excess oil from drain plug  $\text{\textcircled{P}}$ .

1. If the work equipment is not in the condition shown in the diagram on the right, start the engine run the engine at low speed, retract the arm and bucket cylinders, then lower the boom, set the bucket teeth in contact with the ground, and stop the engine.
2. Within 15 seconds after stopping the engine, move each control lever (work equipment and travel) to full stroke in all directions to release the internal pressure.
3. Check sight gauge  $\text{\textcircled{G}}$ . The oil level is normal if between the H and L marks.

### NOTICE

**Do not add oil if the level is above the H line. This will damage the hydraulic equipment and cause the oil to spurt out.**

4. If the level is below the L mark, remove the upper cover of the hydraulic tank and add oil through oil filler  $\text{\textcircled{F}}$ .

For details of the oil to use, see 20. "USE OF FUEL, COOLANT AND LUBRICANTS ACCORDING TO AMBIENT TEMPERATURE".

### REMARK

The oil level will vary depending upon the oil temperature.

Accordingly, use the following as a guide:

- Before operation: around L level  
(Oil temperature 10 to 30°C (50 to 86°F))
- Normal operation: around H level  
(Oil temperature 50 to 80°C (122 to 176°F))

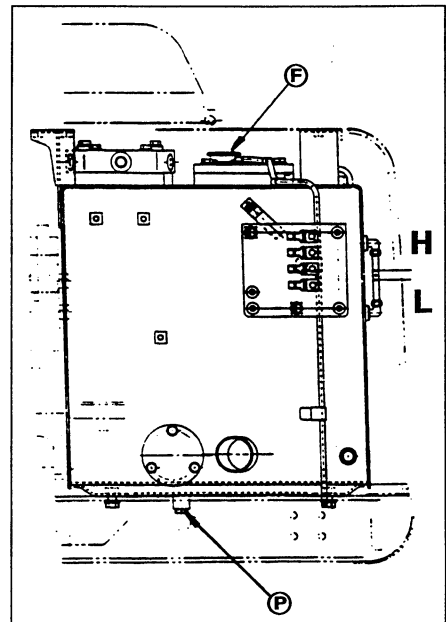
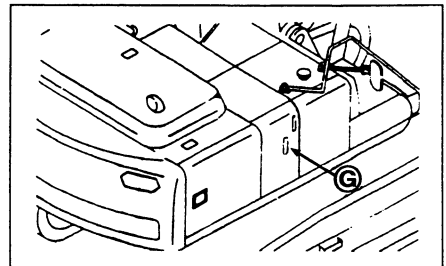
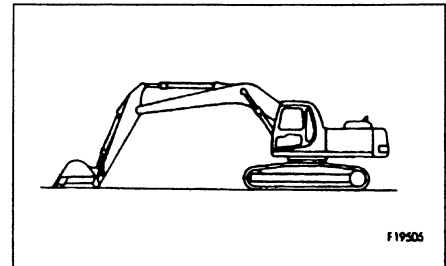

9. Screw in the oil filler cap and install the cover.
10. To bleed the air, start the engine according to 12.2 "STARTING ENGINE" and run the engine at low idling for 10 minutes.
11. Stop the engine.

**REMARK**

Operate the machine after halting for more than 5 minutes to eliminate bubbles in the oil inside the tank.

12. Check for oil leakage and wipe off any spilled oil.

When the hydraulic breaker is installed, the hydraulic oil deteriorates earlier than in normal bucket digging work.

The first element replacement should be at 100 to 150 hours for new machines. Thereafter, replace the element according to the table on the right. Replace the additional filter element for the breaker every approx 250 hours (when breaker operating ratio is more than 50%) according to the table on the right (see 24.2.15 "Replace Additional breaker Filter Element")

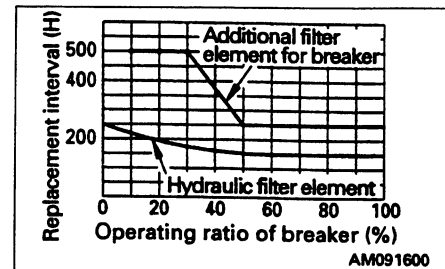

**24.4.4 LUBRICATE SWING CIRCLE (2 points)**

1. Lower the work equipment to the ground.
2. Using a grease pump, pump in grease through the grease fittings shown by arrows.
3. After greasing, wipe off all the old grease that was pushed out.

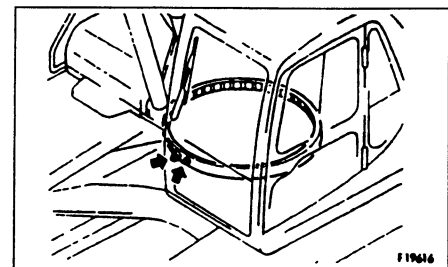

## 24.6 EVERY 1000 HOURS SERVICE

Maintenance for every 50, 100, 250 and 500 hours should be carried out at the same time.

### 24.6.1 CHANGE OIL IN SWING MACHINERY CASE

**⚠ WARNING**

The oil is at high temperature immediately after the machine has been operated. Wait for the oil to cool down before carrying out maintenance.

- Container to catch drained oil: Min. 4 ℓ capacity.
  - Refill capacity: 4 ℓ (1.05 US gal, 0.9 UK gal).
1. Set an oil container under drain plug **P** under the machine body.
  2. Loosen drain valve **P** under the body, drain the oil, then tighten the drain valve again.
  3. Remove dipstick **G** and bleeding plug **I**.  
Add the specified amount of engine oil through gauge hole **F**.

For details of the oil to use, see 20. "USE OF FUEL, COOLANT AND LUBRICANTS ACCORDING TO AMBIENT TEMPERATURE", page 3-12.

4. After refilling, install bleeding plug **I**.
5. Wipe off oil on the dipstick with a cloth.
6. Insert dipstick **G** into the gauge pipe thoroughly and then pull out it again.
7. When the oil level is between the H and L marks, on dipstick **G**, it is normal. If the oil does not reach the L mark, add more oil through oil filler **F**.
8. If the oil level exceeds the H mark, drain the excess engine oil from drain plug **P**, and check the oil level again.

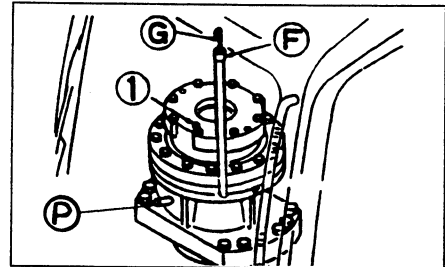

**6. Bleeding air from attachment (if installed).**

For machines equipped with attachments such as the breaker, actuate the attachment pedal about 10 times to bleed the air completely from the attachment circuit while running the engine at low idling.

**NOTE**

**If the attachment bleeding procedure is specified by the manufacturer, bleed the attachment according to such procedure.**

**7. Operation**

1. After completion of bleeding the air, stop the engine, and wait for at least 5 minutes before starting operations. In this way, the air bubbles are removed from the oil inside the hydraulic tank.
2. Check for any leakage of oil, and wipe off any oil that has been spilled.

25. SPECIFICATIONS

PC200EN, PC200EL-6

	1.85m ARM	2.25m ARM	2.62m ARM	2.9m ARM
A	8860 mm	8800 mm	8800 mm	8805 mm
B	3125 mm	2960 mm	2965 mm	3055 mm
C	6040 mm	5135 mm	4750 mm	4555 mm

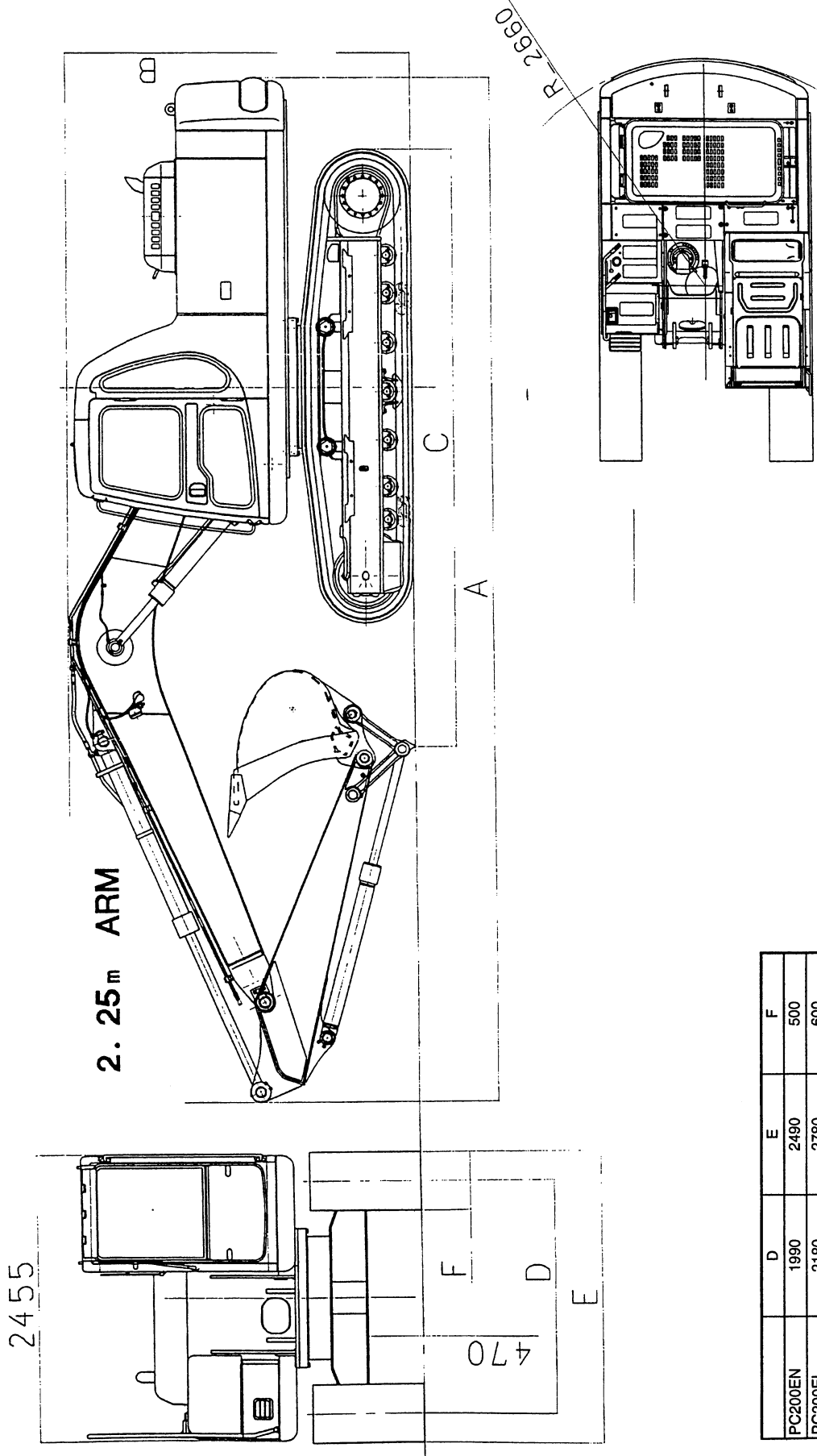

2455

2. 25m ARM

470

	D	E	F
PC200EN	1990	2490	500
PC200EL	2180	2780	600

## 28. MACHINES READY FOR ATTACHMENTS

### 28.1 EXPLANATION OF COMPONENTS

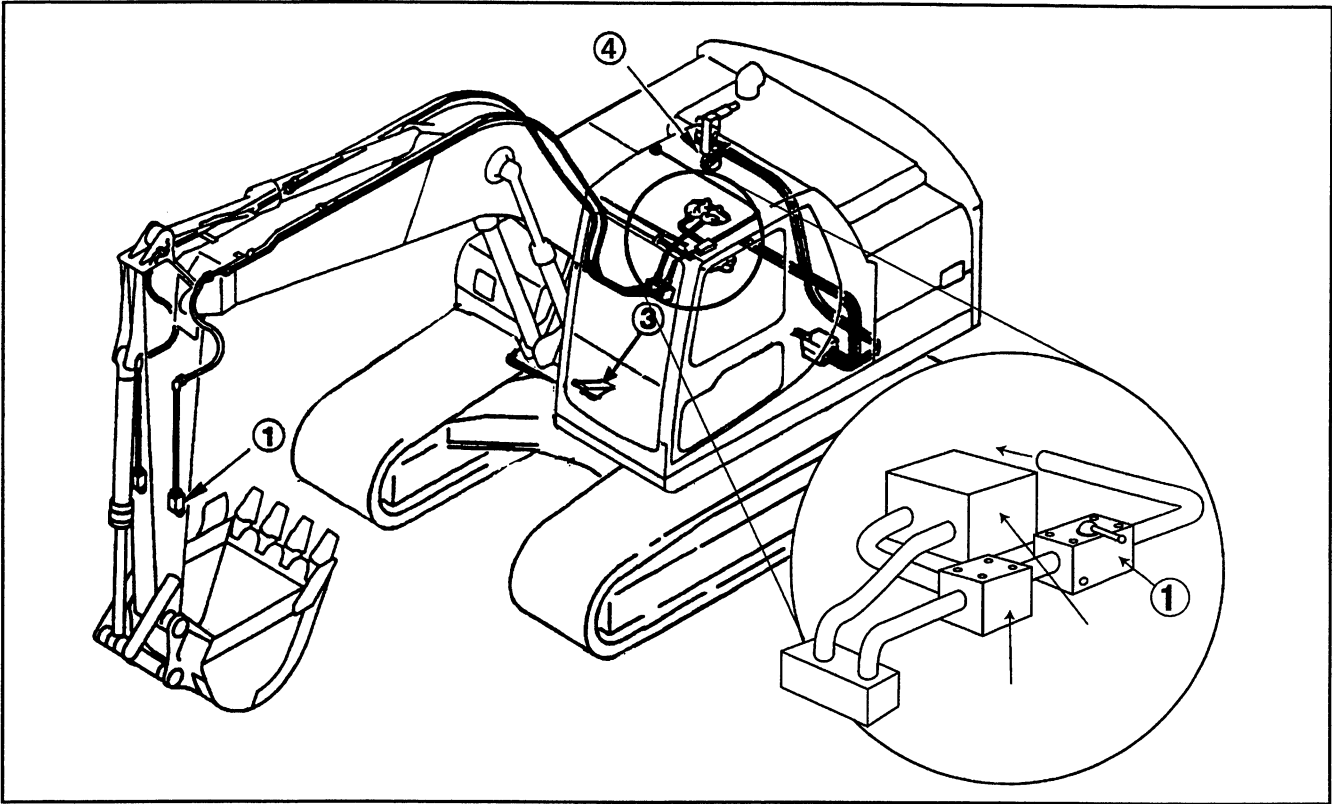

#### 1. STOP VALVE

This valve stops the flow of the hydraulic oil.

① FREE : Hydraulic oil flows.

② LOCK : Hydraulic oil stops.

When removing or installing attachments set this valve to the LOCK position.

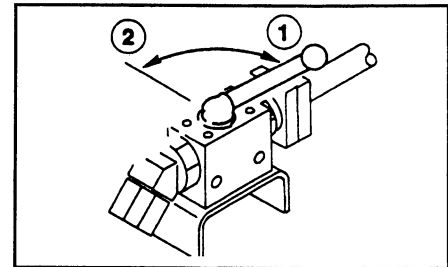

- **PC200EN-6k/PC200EL-6k**

Name	Specifications, use
Narrow bucket	Capacity 0.57 m <sup>3</sup> Outside width 900 mm
Narrow bucket	Capacity 0.64 m <sup>3</sup> Outside width 960 mm
Light duty bucket	Capacity 0.80 m <sup>3</sup> Outside width 1,050 mm
Light duty bucket	Capacity 1.00 m <sup>3</sup> Outside width 1,350 mm
Shape finishing bucket	Capacity 0.35 m <sup>3</sup> Compacting width 2,000 mm <sup>3</sup> Compacting area 2,4 m <sup>2</sup>
Trapezoidal bucket	Capacity 0.50 m <sup>3</sup> Outside width
Ripper bucket	Capacity 0.56 m <sup>3</sup> Outside width 990 mm
One tooth ripper	Shank width 118 mm Crushing depth 1,130 mm
Three teeth ripper	Shank width 118 mm Crushing depth 860 mm
Track shoes	Triple grouser shoe width 500 mm Triple grouser shoe width 600 mm Triple grouser shoe width 700 mm Triple grouser shoe width 800 mm
Short arm	Arm length 1,850 mm Max. digging depth 5,200 mm
Short arm	Arm length 2,250 mm Max. digging depth 5,645 mm
Medium arm	Arm length 2,600 mm Max. digging depth 5,960 mm
Long arm	Arm length 2,900 mm Max. digging depth 6,290 mm
Head guard	In place where there is danger of falling rocks, always install the head guard to protect the operator.

CLICK HERE TO **DOWNLOAD** THE COMPLETE MANUAL

- Thank you very much for reading the preview of the manual.
- You can download the complete manual from: [www.heydownloads.com](http://www.heydownloads.com) by clicking the link below



- Please note: If there is no response to CLICKING the link, please download this PDF first and then click on it.

CLICK HERE TO **DOWNLOAD** THE COMPLETE MANUAL