

# Timberjack 350A Skidder

CALIFORNIA  
Proposition 65 Warning

Diesel engine exhaust and some of its constituents are known to the State of California to cause cancer, birth defects, and other reproductive harm.

If this product contains a gasoline engine:

 **WARNING**

The engine exhaust from this product contains chemicals known to the State of California to cause cancer, birth defects or other reproductive harm.

The State of California requires the above two warnings.

CLICK HERE TO **DOWNLOAD** THE COMPLETE MANUAL

- Thank you very much for reading the preview of the manual.
- You can download the complete manual from: [www.heydownloads.com](http://www.heydownloads.com) by clicking the link below



- Please note: If there is no response to CLICKING the link, please download this PDF first and then click on it.

CLICK HERE TO **DOWNLOAD** THE COMPLETE MANUAL

# Timberjack

## Foreword

To assist the operator in becoming familiar with the many features of the Model 350A skidder and thereby quickly become proficient in the operation and periodic maintenance procedures, this manual is provided with detailed operating and service instructions as well as safety information and equipment data.

Throughout this manual, references are made to the front, rear, left and right hand sides of the skidder. Consider the engine the front end of the machine and determine the left and right hand sides from a seated position in the operator's seat facing the engine.

Where applicable throughout the text "Safety  Alert" symbols have been used to indicate important safety measures. Carefully read, understand and follow these instructions to prevent hazardous situations and possible personal injuries.

The instructions and procedures in this manual cover two basic machine models furnished with the most commonly used options; therefore pictorial presentation in some areas may vary slightly from the actual machine on hand. This variation, however, does not have any impact on the accuracy of the written information.

The information contained in this manual is current at the time of publication; however, continuing product improvement may result in changes to the machine which are not covered. Should information regarding such changes or any further information on the machine be required, please contact your TIMBERJACK dealer.

# Timberjack

## Controls and Instrumentation

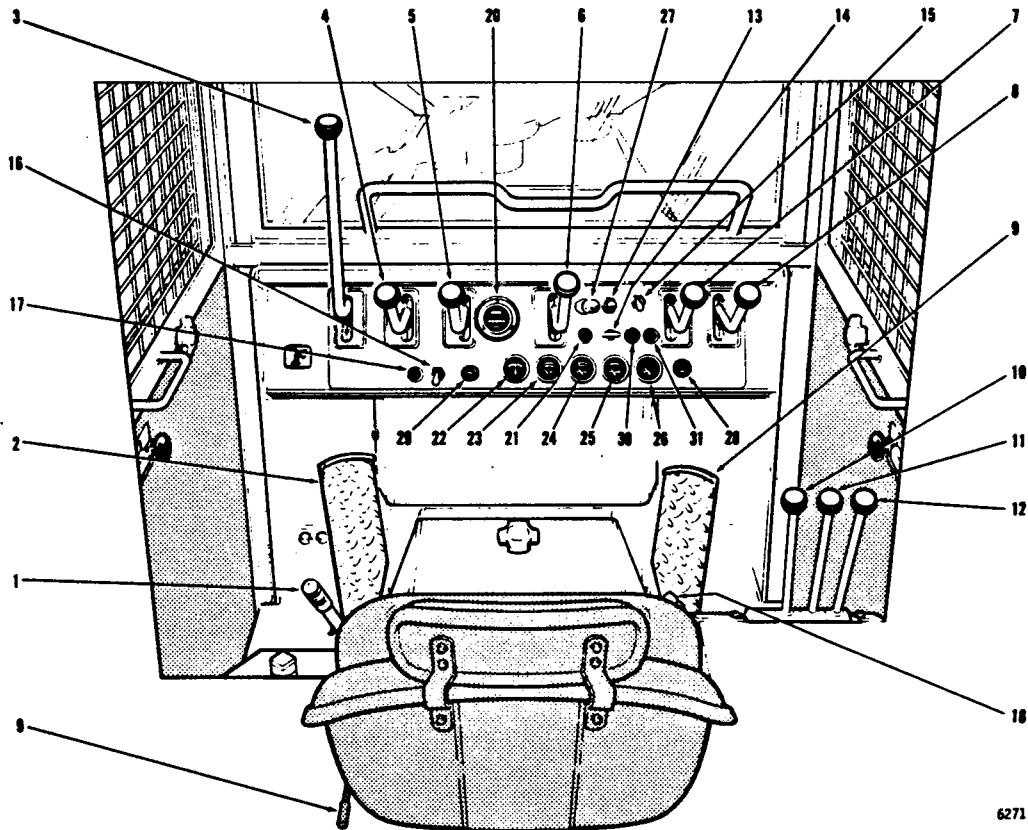

6271

- |                                  |                                     |
|----------------------------------|-------------------------------------|
| 1. Parking Brake                 | 17. Emergency Steering Indicator ** |
| 2. Main Service Brake            | 18. Main Disconnect Switch          |
| 3. Secondary Service Brake       | 19. Seat Adjustment Lever           |
| 4. Transmission Range Selector   | 20. Hourmeter                       |
| 5. Transmission Forward/Reverse  | 21. Parking Brake "ON" Indicator    |
| 6. Steering Lever                | 22. Ammeter                         |
| 7. Dozer Blade Control           | 23. Engine Oil Pressure Gauge       |
| 8. Winch Control                 | 24. Engine Head Temperature Gauge   |
| 9. Accelerator                   | 25. Transmission Pressure Gauge     |
| 10. Grapple Arch Control *       | 26. Converter Temperature Gauge     |
| 11. Grapple Tongs Control *      | 27. Dashboard Light **              |
| 12. Grapple Rotation Control *   | 28. Washer/Wiper Switch **          |
| 13. Engine Preheat/Start Switch  | 29. Heater Control **               |
| 14. Engine Stop Control          | 30. Engine Preheat Indicator        |
| 15. Light Switch                 | 31. Fan Belt Failure Indicator      |
| 16. Emergency Steering Switch ** |                                     |
- \* Furnished on all grapple skidders.  
 \*\* Optional.

CONTROLS AND INSTRUMENTATION  
 FIGURE 2-2

# Timberjack

## Operating the winch

Winch operations are generally done when the skidder is stationary (parked). The felling pattern and timber density as well as the terrain condition are factors that determine how the winching is done.

### **⚠ CAUTION**

PERFORM WINCHING OPERATIONS ONLY WHEN THE SKIDDER IS ALIGNED WITH THE LOAD TO BE WINCHED IN. WINCHING A LOAD AT AN ANGLE TO THE SKIDDERS ORIENTATION CAN BE HAZARDOUS AND MAY RESULT IN ACCIDENTS.

1. To perform winch operation; park the machine, engage the parking brake, lower the dozer blade to the ground and select the transmission in neutral.

### **⚠ WARNINGS:**

1. ENSURE THAT THE SKIDDER IS PARKED IN A SAFE POSITION BEFORE WORK BEHIND IT IS INITIATED. FAILURE TO OBSERVE A SAFE WORK PRACTICE CAN LEAD TO SERIOUS OR FATAL ACCIDENTS.

2. PREVENT HAND INJURIES; USE GLOVES WHEN HANDLING WINCH CABLES.

2. To attach a load to the winch cable, pull the winch control lever to position "B", refer to illustration below. In this position the winch brake is fully released and thus permits the operator to free spool the winch cable as required. The control lever is equipped with a detent mechanism which will hold the lever in the actuated position until it is manually repositioned.

### NOTE:

The winch is equipped with a drag brake to restrict free spooling of the cable drum beyond the operator's control. Limiting free spooling prevents overrun and tangle of the winch cable.

3. To winch in an attached load, operate the control lever toward the "A" position as shown. The winch clutch will begin to engage and the brake release, when the lever is moved forward of the neutral "N" position. The clutch is completely engaged when the control lever is fully actuated.

### NOTE:

To increase or decrease the winching speed, increase or decrease the engine rpm.

Maximum winching speed and line pull is achieved at maximum engine rpm.

4. When the load is satisfactorily positioned, release the control lever. A spring mechanism will return the lever to neutral, "N" position, and thereby engage the winch brake and release the clutch.

### NOTE:

During normal skidding operations, the load should be raised as high and as close to the skidder as possible to reduce drag and prevent the timber from being "caught" by any obstacles on the ground.

5. To drop or release a load from the skidding position, operate the control lever to position "B", free spool position.

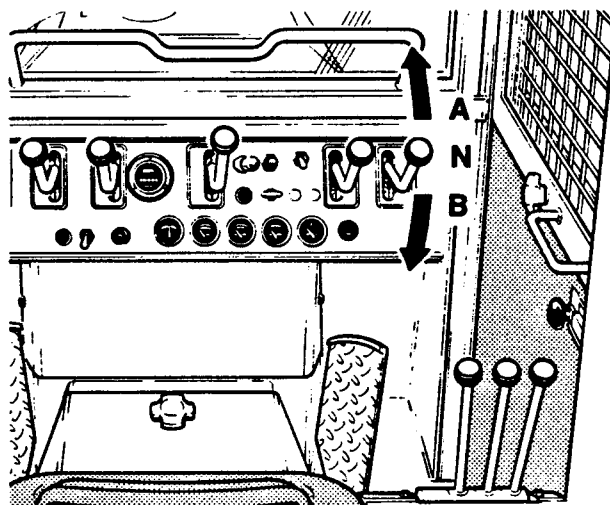

OPERATING THE WINCH  
FIGURE 2-17

5597

## Positioning the Fairlead

1. In forestry operations where the terrain is relatively dry and level and the timber primarily consists of small wood, the fairlead should be adjusted to its highest position to enable skidding of the largest possible loads.

# Timberjack

## Maintenance Schedule

### EVERY 8-10 HOURS (DAILY)

1. Check engine oil level.
2. Check (clean) air filter pre-cleaner. \*
3. Check (clean) engine air filter. \*\*
4. Check hydraulic fluid level.
5. Check transmission fluid level
6. Check function of gauges.
7. Check function of brakes.
8. Check fuel level.
9. Lubricate steering hinge pins and walking beam.
10. Lubricate frame hinge pins.
11. Lubricate all hinge points on grapple, boom, arch and cylinders.
12. Drain fuel line water separator.
13. Clean dirt and debris from external surfaces and engine compartment.
14. Check grapple head snubber adjustment.
15. Check and fill windscreen washer reservoir.

### NOTES:

\* More frequent cleaning may be required in extremely dusty environments.

### EVERY 50 HOURS

16. Check function of steering system including emergency steering.
17. Check main service brake master cylinder fluid level.
18. Check secondary brake master cylinder fluid level.
19. Check oil levels in planetary hubs and axle differentials.
20. Check (clean) axle breathers.
21. Check tire conditions and pressure.
22. Check fire extinguisher pressure.
23. Check winch oil level.
24. Lubricate winch shaft bearing. (T20 winch only).
25. Check reduction box oil level.
26. Lubricate driveshaft fittings.\*\*\*
27. Lubricate dozer blade pivots.\*\*\*
28. Inspect the machine for loose fasteners, oil leaks, unusual wear and damage.

\*\* The cleaning frequency may be extended from daily to 50 hours depending on the environmental dust conditions.

\*\*\* Under very wet and muddy conditions more frequent lubrication is required.

# Timberjack

## **⚠ WARNING:**

BEFORE WORKING UNDER THE MACHINE, ENSURE THAT IT IS PARKED ON LEVEL GROUND WITH THE PARKING BRAKE ENGAGED, THE WHEELS BLOCKED, THE DOZER BLADE AND GRAPPLE LOWERED AND THE ENGINE STOPPED.

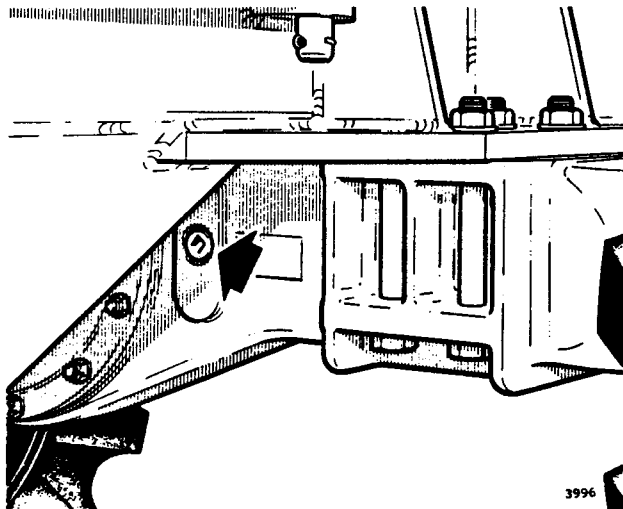

AXLE DIFFERENTIAL OIL CHECK  
FIGURE 3-21

## ITEM 20

Check and, if necessary, clean the front and rear axle breathers. Also clean the area around each breather.

Breathers are installed in the axle housings to equalize the inside pressure with the ambient pressure. Failure to keep the breathers and surrounding areas clean may result in increased internal pressure and subsequent oil seal leakage.

Both the front and the rear axle breathers are located on top of the axles close to the differentials. The front axle breather is accessible from the right hand side of the machine and the rear axle breather is accessible from the left hand side between the axle and the frame.

## ITEM 21.

Check the tire conditions and pressure. Early detection of cuts and other damage may easily be repaired and thus extend the tire service life. Check the tire pressure and inflate as required.

## **⚠ WARNING:**

MAKE SURE THE TIRES AND RIMS ARE UNDAMAGED AND CORRECTLY ASSEMBLED. USE SAFETY CABLES OR OTHER SAFETY DEVICES WHEN INFLATING THE TIRES. FAILURE TO OBSERVE APPROPRIATE SAFETY PRECAUTIONS CAN RESULT IN SERIOUS PERSONAL INJURIES.

Make sure the valve stem protective caps are reinstalled on all wheels when checks and inflating procedures are completed.

## ITEM 22.

Check the fire extinguisher pressure. A waterproof pressure gauge on the extinguisher indicates the charge pressure of the unit. Normally, this charge pressure is approximately 175 psi. (1200 kPa) and is indicated in a white band on the gauge. If the pressure drops due to leakage or use, the fire extinguisher must be recharged to be efficient in an emergency situation.

When inspecting the fire extinguisher, observe that the hose, nozzle and valve are undamaged and ready for use. Check also the fire extinguisher securing strap to ensure that the locking mechanism works smoothly and can be opened quickly if required.

## ITEM 23.

Check the winch oil level. The check plug on both the T20 and the T30 (Gearmatic) winch is accessible from the left hand side of the skidder as shown in figure 3-22, item 1.

The skidder must be parked on level ground when the winch oil level is checked.

With the check plug removed, the oil level should be even with the bottom of the check plug hole. If required, replenish the oil through the filler opening, item 2, at the top of the winch. Use oil as specified in table 3-1. Ensure that the check and filler plugs are securely installed when check and replenishment procedures are completed.

## ITEM 24.

Lubricate the winch shaft bearing (T20 winch only). Lubricate where shown in figure 3-23 using a grease gun and grease as specified in table 3-1.

# Timberjack

## NOTE:

The oil change is best accomplished while the oil is warm. The warm oil has a relatively low viscosity and, therefore, drains easier. Also, any foreign particles will still be suspended and drain out with the oil.

## ITEM 49.

Change differential oil. Remove the check plug on the side of front and rear axles, refer to figure 3-41. Remove the drain plugs located at the bottom of each differential housing and drain the oil into a suitable container.

When the oil has drained from both differentials, clean and reinstall the drain plugs and through the check plug openings, pour fresh oil until the level in each axle reaches the bottom of the check plug opening. Use oil of appropriate type and viscosity as specified in table 3-1.

Reinstall the check plugs once the oil change is completed.

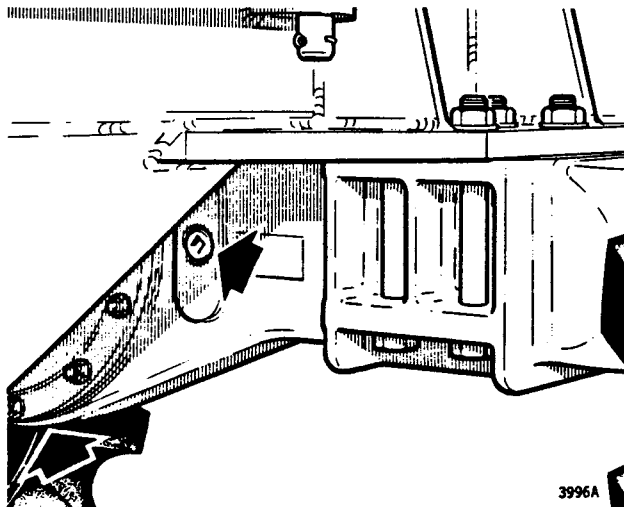

AXLE DIFFERENTIAL OIL CHANGE  
FIGURE 3-41

## ITEM 50.\*

Change the reduction box oil. The oil should be changed shortly after the vehicle has been in operation while the oil is warm and any foreign particles still suspended in the fluid.

The reduction box oil drain plug is located as shown in figure 3-42. Remove the drain plug (1) and the filler plug (2) and drain the oil into a suitable container. Ensure that the drain plug is securely installed once the oil is drained.

Pour fresh oil into the reduction box and reinstall the filler plug. Refer to table 3-1 for appropriate oil type and quantity.

\* Machines with T20 winch only.

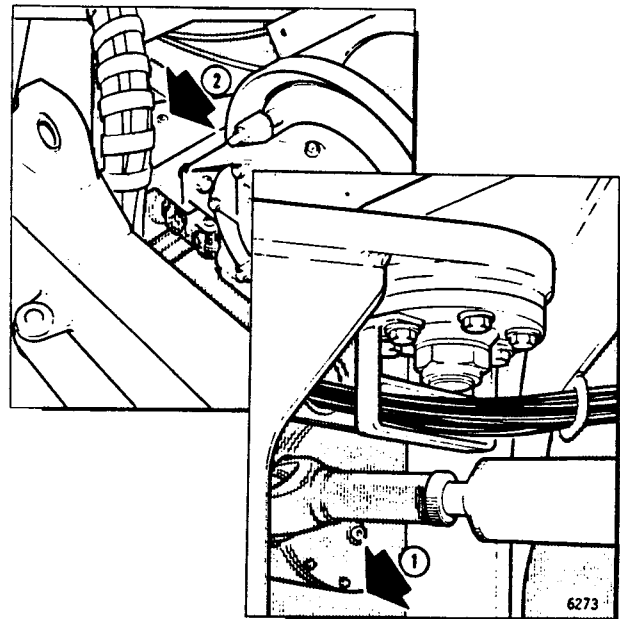

REDUCTION BOX OIL CHANGE  
FIGURE 3-42

## ITEM 51.

Change the winch oil. The winch drain plug is located in the bottom of the worm gear housing, ref. figure 3-43 or 3-44 as applicable. While the oil is warm from operation, remove the plug (1) and drain the oil into a suitable container. Remove the filler plug (2) at the top of the worm gear housing to speed up the draining process.

When the oil is completely drained, reinstall the drain plug and pour fresh oil into the winch housing. Use oil of appropriate type and quantity as specified in table 3-1. Reinstall the filler plug once the re-filling is completed.

# Timberjack

## Section 4 - Equipment Data

### Model 350A Cable Skidder

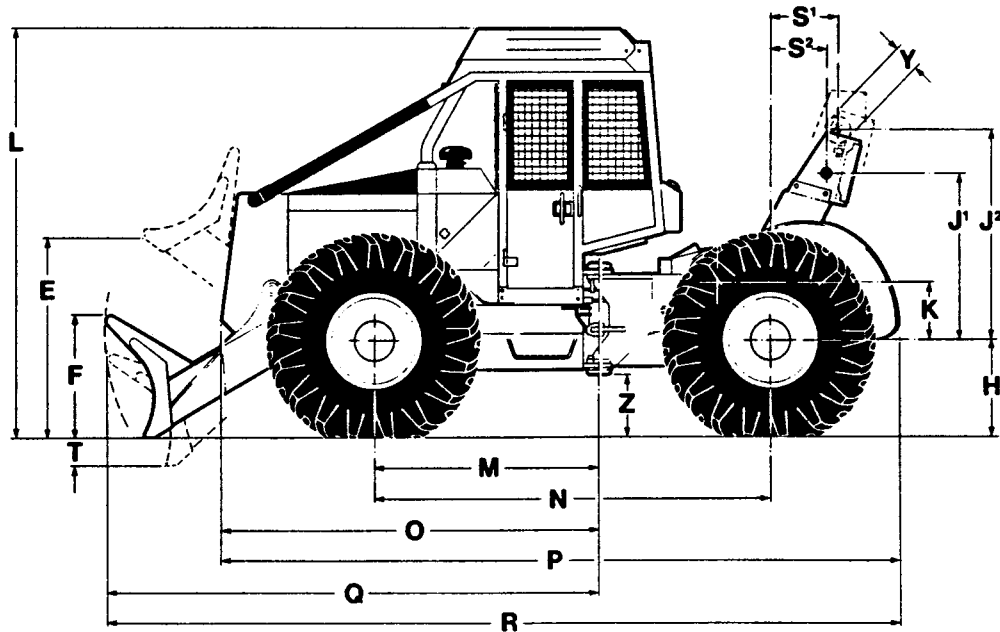
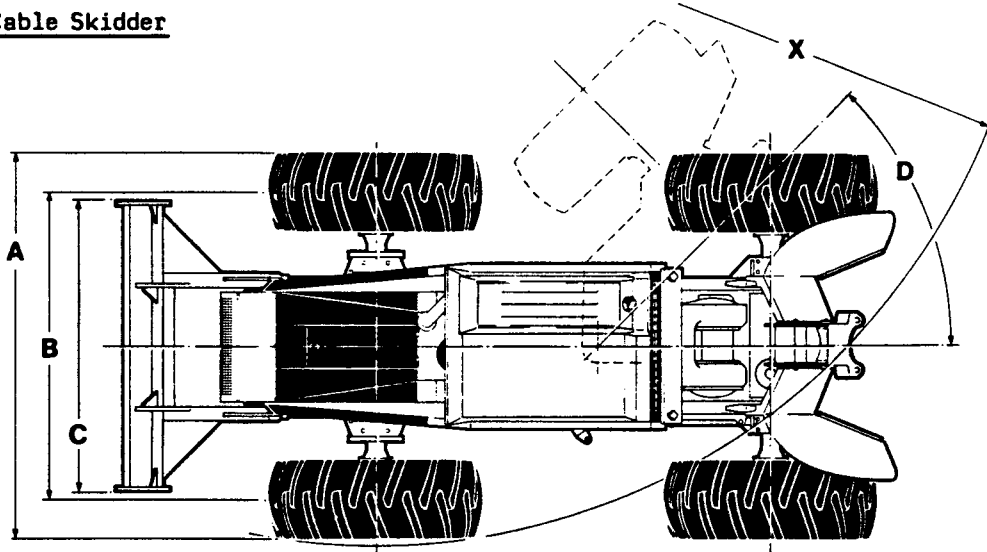

Based on 24.5 x 32 tires

A = 114 (2896 mm)  
 B = 89 (2260 mm)  
 C = 84 (2134 mm)  
 D = + 45 deg.  
 E = 58" (1473 mm)  
 F = 29 (736 mm)

H = 33 (838 mm)  
 J1 = 48 (1219 mm)  
 J2 = 60" (1524 mm)  
 K = 15 (381 mm)  
 L = 127 (3226 mm)  
 M = 66" (1676 mm)

N = 116 (2946 mm)  
 O = 116 (2946 mm)  
 P = 205" (5207 mm)  
 Q = 145 (3683 mm)  
 R = 234" (5944 mm)  
 S1 = 17" (432 mm)

S2 = 21 (533 mm)  
 T = 6 (152 mm)  
 X = 187" (4750 mm)  
 Y = 7 (178 mm)  
 Z = 24 (609 mm)

CLICK HERE TO **DOWNLOAD** THE COMPLETE MANUAL

- Thank you very much for reading the preview of the manual.
- You can download the complete manual from: [www.heydownloads.com](http://www.heydownloads.com) by clicking the link below



- Please note: If there is no response to CLICKING the link, please download this PDF first and then click on it.

CLICK HERE TO **DOWNLOAD** THE COMPLETE MANUAL