

740E Skidder and 748E Grapple Skidder



JOHN DEERE

OPERATORS MANUAL 740E Skidder and 748E Grapple Skidder

OMT151433 K3 English

John Deere Dubuque Works

OMT151433 K3

(This manual replaces OMT145113)

LITHO IN U.S.A.
ENGLISH



0
C
D

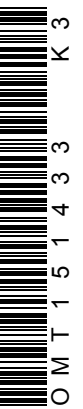

K 3
3
3
4
1
5
1
T
O

CLICK HERE TO **DOWNLOAD** THE COMPLETE MANUAL

- Thank you very much for reading the preview of the manual.
- You can download the complete manual from: www.heydownloads.com by clicking the link below



- Please note: If there is no response to CLICKING the link, please download this PDF first and then click on it.

CLICK HERE TO **DOWNLOAD** THE COMPLETE MANUAL



AVOID INJURY FROM BACKOVER ACCIDENTS

BEFORE MOVING MACHINE, BE SURE ALL PERSONS ARE CLEAR OF AREA

ALWAYS BE ALERT FOR BYSTANDERS MOVING INTO THE WORK AREA. USE HORN OR OTHER SIGNAL TO WARN BYSTANDERS BEFORE MOVING MACHINE

WHEN USING A SIGNAL PERSON, KEEP PERSON IN VIEW AT ALL TIMES. BE SURE SIGNAL PERSON IS CLEAR BEFORE BACKING UP

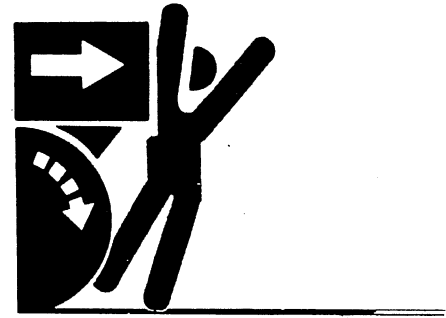

To avoid backover accidents:

Always look around before you back up. Be sure that everyone is in the clear.

Keep bystanders away from pivot area of an articulated machine.

Keep reverse warning alarm in working condition, if equipped.

Use a signal person when backing up if view is obstructed. Always keep signal person in view.

Learn the meaning of all flags, signs, and markings used on the job, and who has the responsibility for signaling.

Keep windows, mirrors, and lights clean and in good condition.

Dust, heavy rain, fog, etc., can reduce visibility. As visibility decreases, reduce speed and use proper lighting.

Read and understand the operating instructions in this operator's manual.

T7241AY -UN-21FEB90

TX.05.DH1573 -19-18MAR91



PRACTICE SAFE MAINTENANCE

Understand service procedures before doing work. Keep area clean and dry.

Never lubricate or service machine while it is moving. Keep hands, feet, and clothing from power-driven parts.

Before servicing machine:

- Park the machine on a level surface.
- Engage park brake.
- Lower blade and grapple, if equipped, to the ground.
- Turn key off to stop engine.
- Allow engine to cool.

If maintenance procedure must be performed with engine running, do not leave machine unattended.

Securely support any machine elements that must be raised for service work.

Keep all parts in good condition and properly installed. Fix damage immediately. Replace worn or broken parts. Remove any buildup of grease, oil or debris.

Turn battery disconnect switch to OFF before making adjustments on electrical systems or welding on machine.



TS218 -JUN-23AUG88

TX,05,RR,795 -19-10DEC92

SUPPORT MACHINE PROPERLY

Always lower the attachment or implement to the ground before you work on the machine. If you must work on a lifted machine or attachment, securely support the machine or attachment.

Do not support the machine on cinder blocks, hollow tiles, or props that may crumble under continuous load. Do not work under a machine that is supported solely by a jack. Follow recommended procedures in this manual.

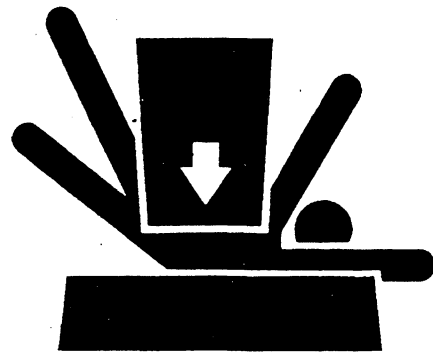

TS229 -JUN-23AUG88

DX,LOWER -19-04JUN90



A—Safety Decal

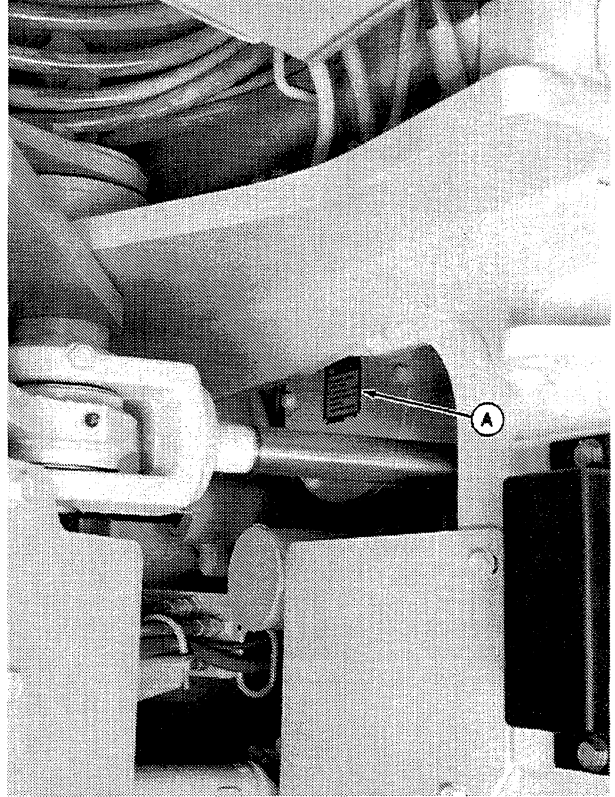

T7511CL -19-05JUN91

T7511CX -UN-12AUG91

TX,06,RR,1837 -19-27MAR92

ENGINE COOLANT TEMPERATURE GAUGE

Needle may point to black zone (A) until engine is warm. Normal operating temperature is in the green zone (B).

IMPORTANT: DO NOT stop engine when needle enters red zone or temperature will rise further. Reduce load immediately and run engine at 1/2 speed.

If needle enters red zone (C), reduce load immediately and run engine at 1/2 speed. Allow engine to cool. Shut off engine. Inspect for clogged radiator core or coolant leakage.

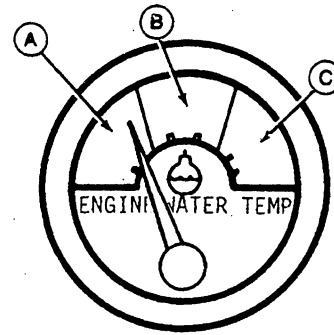

XX

TX,10,DH483 -19-22DEC92

T6603CE -UN-18OCT88

FUEL GAUGE

Always fill fuel tank at the end of the day to eliminate condensation in fuel tank.

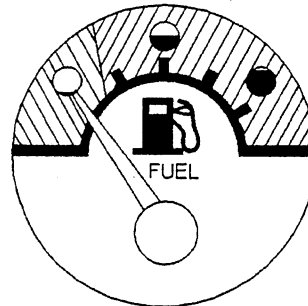

TX,10,RR,765 -19-03SEP91

T7352AC -19-25SEP90

PEDALS

- A—Accelerator Pedal
- B—Service Brake Pedal
- C—Clutch Pedal

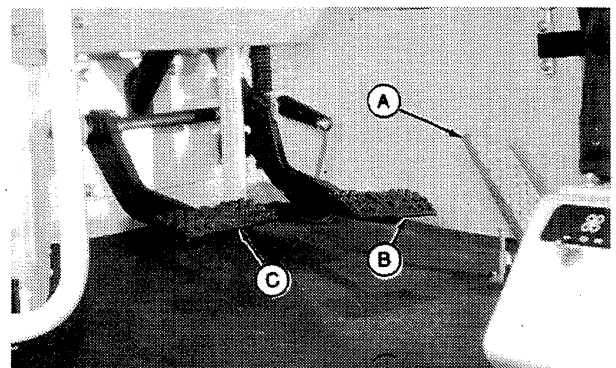

TX,10,RR,1901 -19-27MAR92

T7510Z -UN-10OCT91

Operating the Engine

CHECK INSTRUMENTS BEFORE STARTING

1. Move transmission control and park brake lever (A) to "BRAKE ON" position "P". (Lever sleeve (B) must drop into slot of console.)

2. Turn key switch clockwise and hold in BULB CHECK position.

- All indicator lights must light.
- If any indicator light fails to light, the bulb may be burned out.

3. Turn key switch to OFF position. All indicator lights must go out.

4. Turn key switch clockwise to BULB CHECK position and release immediately.

If a function is engaged, the following indicator lights will light:

- Engine oil pressure
- Park brake
- Alternator voltage
- Transmission oil pressure
- Differential lock

If any of these fail to light, see your authorized dealer.

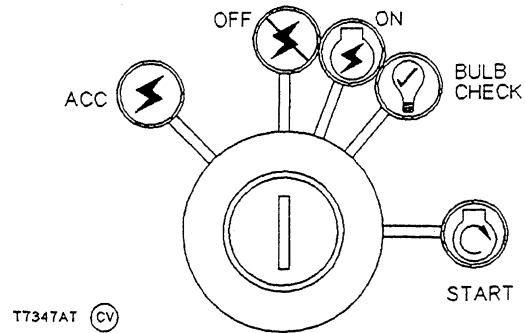
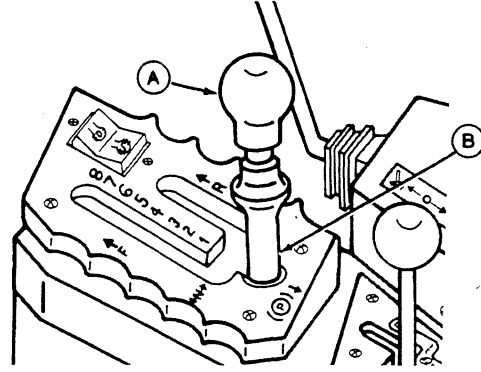

T7436AD2 -UN-02JAN91

T7347AT -19-25SEP90

TX,25,RR,755 -19-30NOV92

Driving the Machine

DRIVING ON PUBLIC ROADS

Before driving on public roads, check state and local laws that may apply to tractors, self-propelled machines, and towed equipment. Additional lights, mirrors, SMV emblems, or reflectors may be required.

TX,30,DH2719 -19-12APR93

GENERAL DRIVING PRECAUTIONS



CAUTION: Prevent possible injury from unexpected machine movement. Never allow riders other than the operator to get on the machine.

In general, observe all safe driving rules such as:

- Slowing down for curves
- Avoiding rapid steering or braking
- Watching out for bystanders
- Watching out for other operators
- Looking behind before backing up

TX,30,DH2092 -19-27MAR92

GRAPPLE AND BOOM CONTROL LEVERS (SINGLE FUNCTION)

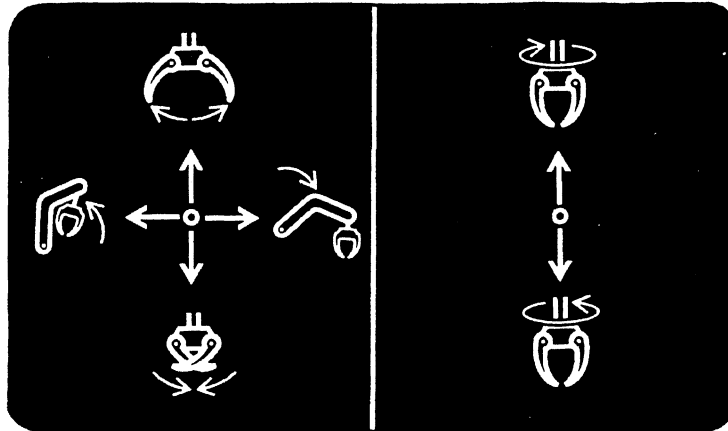

T7380AE
-UN-18OCT90

1. Push lever forward (A) to raise boom.
2. Pull lever rearward (C) to lower boom.
3. Push lever to right (B) to open grapple.
4. Pull lever to left (D) to close grapple.

When skidding logs, pull lever to position (D) detent. This keeps a clamping force on the load at all times.

5. Push lever to right (E) to rotate grapple clockwise.
6. Pull lever to left (F) to rotate grapple counterclockwise.

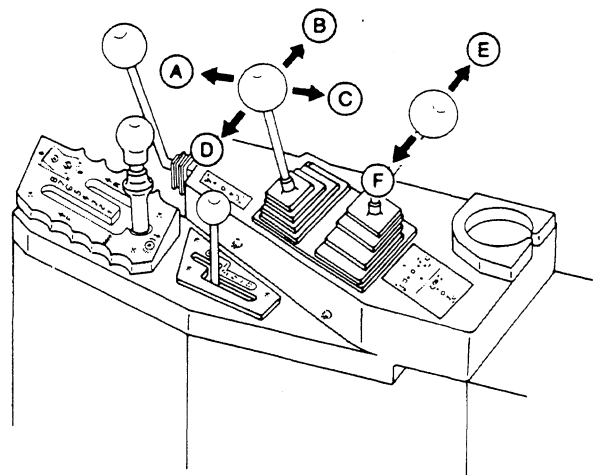

T7436AH4
-UN-04JAN91

TX.35,RR.1464 -19-27MAR92

STORING FUEL

If there is a very slow turnover of fuel in the fuel tank or supply tank, it may be necessary to add a fuel conditioner to prevent water condensation. Contact your authorized dealer for proper service or maintenance recommendations.

TX,45,DH2536 -19-03SEP92

DO NOT USE GALVANIZED CONTAINERS

IMPORTANT: Diesel fuel stored in galvanized containers reacts with zinc coating on the container to form zinc flakes. If fuel contains water, a zinc gel will also form. The gel and flakes will quickly plug fuel filters and damage fuel injectors and fuel pumps.

DO NOT USE a galvanized container to store diesel fuel.

Store fuel in:

- plastic containers.
- aluminum containers.
- specially coated steel containers made for diesel fuel.

DO NOT USE brass-coated containers: brass is an alloy of copper and zinc.

MX,FLBT,C -19-04JUN90

FUEL TANK

CAUTION: Handle fuel carefully. If the engine is hot or running, do not fill the fuel tank. Do not smoke while you fill fuel tank or work on fuel system.

To avoid condensation, fill the fuel tank at the end of each day's operation. Capacity is 234 L (62 gal).



TS185
-JUN-23AUG88

TX,45,RR,1488 -19-24APR92

OILSCAN® AND COOLSCAN™

OILSCAN and COOLSCAN are John Deere sampling programs to help you monitor machine performance and identify potential problems before they cause serious damage.

Oil and coolant samples should be taken from each system prior to its recommended change interval.

Check with your John Deere dealer for the availability of OILSCAN and COOLSCAN kits.

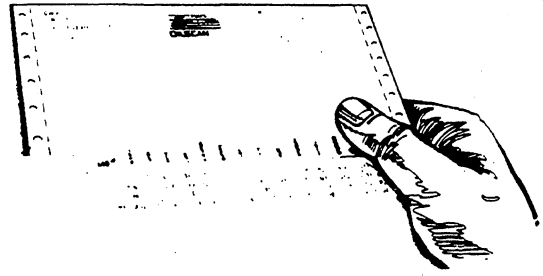
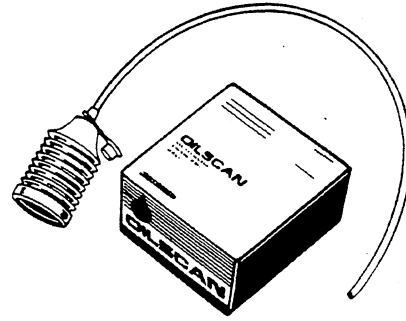

DX,OILSCAN -19-16APR92

T6829AB -UN-15JUN89

T6829AB

-UN-18OCT88

T6829AB

DRAIN FINAL FUEL FILTER

1. Open right side shield to access final fuel filter.
2. Place container under filter.
3. Loosen drain screw (A). Drain water for several seconds.
4. Tighten drain screw.

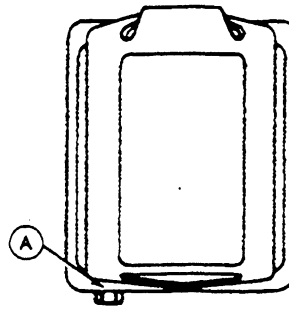

TX,55,DH2624 -19-30NOV92

T6201AM2 -JUN-18OCT88

Maintenance—Every 100 Hours

LUBRICATE AXLE UNIVERSAL JOINTS

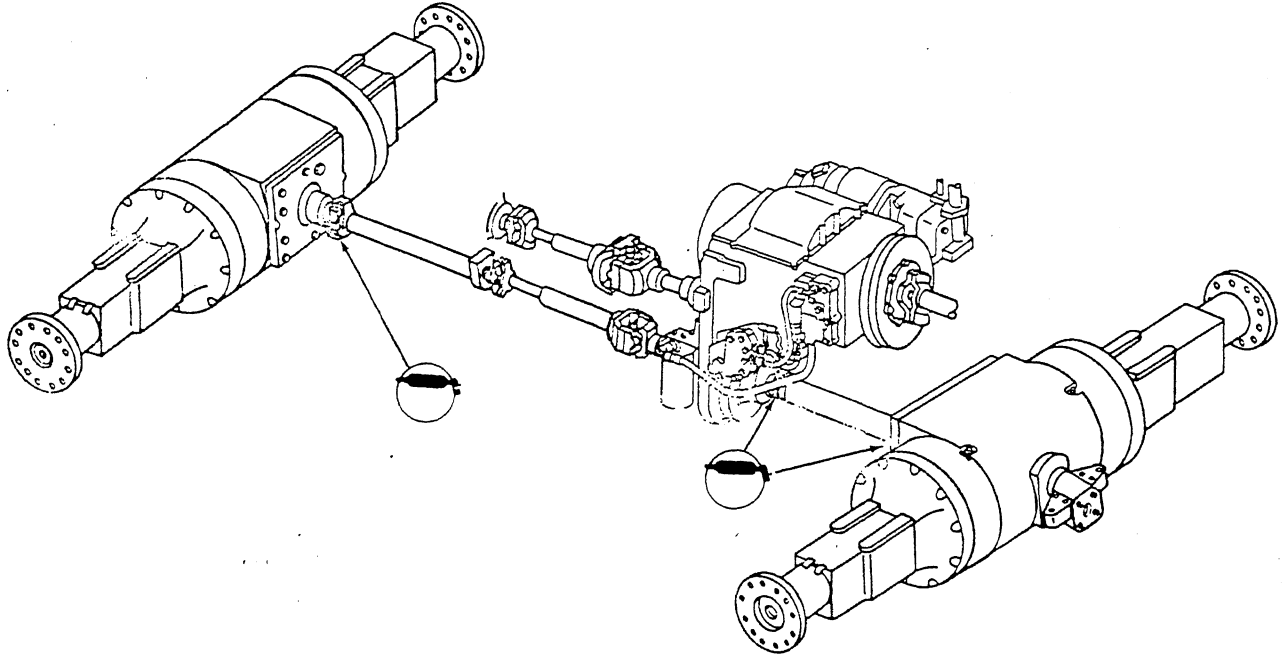

Use a low pressure grease gun.

1. Remove bottom guards.
2. Lubricate three joints until grease escapes around seals.

NOTE: Lubricate daily when operating in deep mud, water, or snow. Clean out all debris inside the machine frame area.

TX,65,RR,843 -19-03SEP91

T7382AM -UN-03OCT90

REPLACE HYDRAULIC RESERVOIR BREATHING FILTER

1. Open cover (A) to access hydraulic reservoir breather.
2. Replace breather filter (B).

NOTE: Cover removed for clarity of photograph.

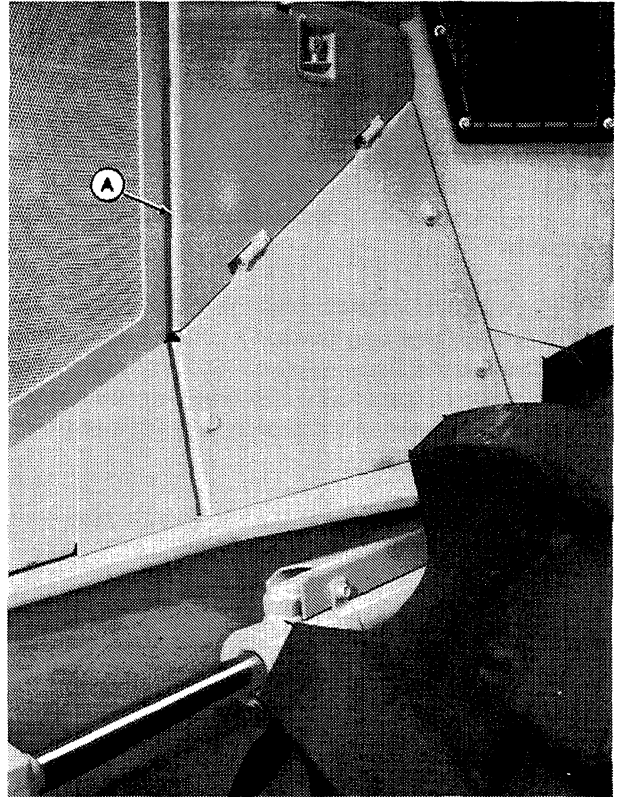

T7380AV -UN-27SEP90

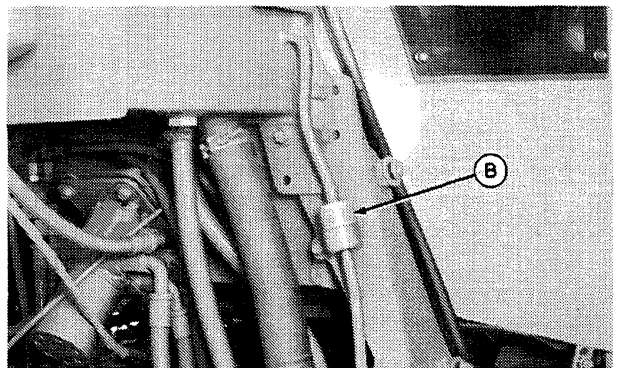

T7380AW -UN-27SEP90

TX,80,RR,876 -19-10DEC92

CLICK HERE TO **DOWNLOAD** THE COMPLETE MANUAL

- Thank you very much for reading the preview of the manual.
- You can download the complete manual from: www.heydownloads.com by clicking the link below



- Please note: If there is no response to CLICKING the link, please download this PDF first and then click on it.

CLICK HERE TO **DOWNLOAD** THE COMPLETE MANUAL

16. Fill transmission with oil at fill tube (A). (See Fuels and Lubricants chapter.)
17. Place winch control lever in FREE SPOOL position.
18. Run engine for 5 minutes at slow idle engine speed.
19. Shut engine off.
20. Pull dipstick (B), wipe it clean, and re-insert fully into dipstick tube. Wait an additional 5 minutes and pull dipstick and check oil level. Oil level should be on the crosshatched area (C) of the dipstick.

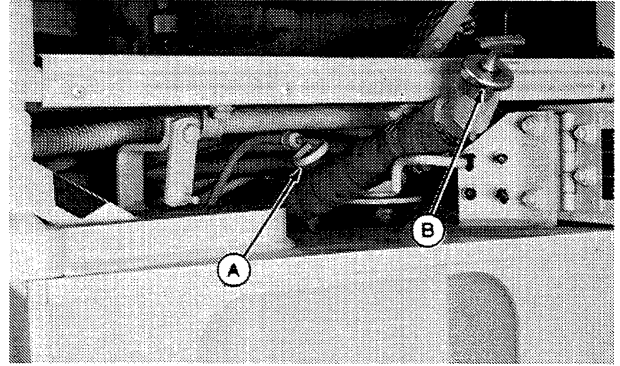

T7572AK -UN-10OCT91



T7747AX -UN-29APR92

TX,85,DH2238 -19-24APR92

CHANGE HYDRAULIC SYSTEM OIL

1. Park machine on level surface. Lower blade to ground.
 - On single function grapple machine, close tongs and lower grapple head to ground with arch.
 - On dual function grapple machine, close tongs, fully extend boom cylinders, and lower grapple head to ground with arch.
2. Stop engine.
3. Remove hydraulic reservoir filler cap.

SPECIFICATION

Oil capacity 41.6 L (11 gal)

4. Remove hydraulic reservoir drain plug (A).
5. Replace hydraulic oil filter. (See Maintenance—Every 500 Hours chapter.)

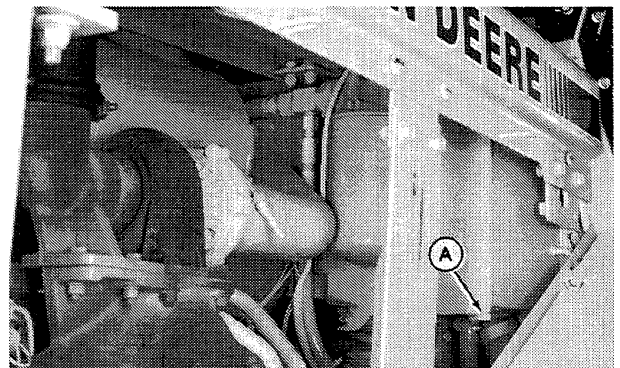

T7382AW -UN-03OCT90

TX,85,DH2106 -19-23APR92

DO NOT SERVICE INJECTION NOZZLES

IMPORTANT: Do not service or remove injection nozzles. The service life of the injection nozzles may be shortened by:

**Overheating
Improper operation
Poor quality fuel
Excessive idling**

If injection nozzles are not working correctly or are dirty, the engine will not run normally. (See your authorized dealer for service.)

TX,90,DH1583 -19-10DEC92

DO NOT ADJUST INJECTION PUMP

IMPORTANT: Never steam clean or pour cold water on an injection pump while the engine is running, or while injection pump is still warm. To do so may cause seizure of pump.

Clean trash regularly from injection pump.

Adjusting the injection pump in any way not approved by the manufacturer will end the warranty. (See your copy of the John Deere warranty on this machine.)

Do not attempt to service an injection pump that is not operating correctly. (See your authorized injection pump service center.)

TX,90,DH626 -19-26SEP91

BLEEDING PARK BRAKE SENSOR VALVE

The park brake sensor valve must be bled after any repair to park brake or transmission control valve, or removal of any hoses attached to park brake. Air in this circuit will prevent engagement of transmission if control lever is moved rapidly from the park brake position. A normal shift response time is 0.2—0.3 seconds, measured from park brake position to 1st gear forward.

IMPORTANT: Transmission oil level must be at proper level before attempting this bleed procedure. Low oil level will cause aeration of oil which will keep putting air in circuit you are trying to bleed.

1. Check transmission oil level and adjust as required. (See Maintenance—Every 10 Hours or Daily chapter.)
2. Remove right access door from engine frame to access park brake sensor valve housing located on transmission control valve.

CAUTION: The park brake circuit operates at approximately 3500 kPa (38.48 bar) (500 psi) and the bleed hose may blow off if not attached in place during bleeding procedure. Escaping fluid under pressure can penetrate the skin causing serious injury.

If an accident occurs, see a doctor immediately. Any fluid injected into the skin must be surgically removed within a few hours or gangrene may result. Doctors unfamiliar with this type of injury should reference a knowledgeable medical source.

3. Open bleed screw (A) and attach a 2.13 m (7 ft) of 3/16 clear plastic hose (B) to bleed screw with hose clamp. Route hose over doorway hand rail and secure in transmission fill tube.
4. Start engine at slow idle and hold service brakes ON during this procedure.

NOTE: With control lever in park brake position, some leakage is normal from bleed screw. When transmission control lever is shifted to neutral, oil should spray out bleed hose.

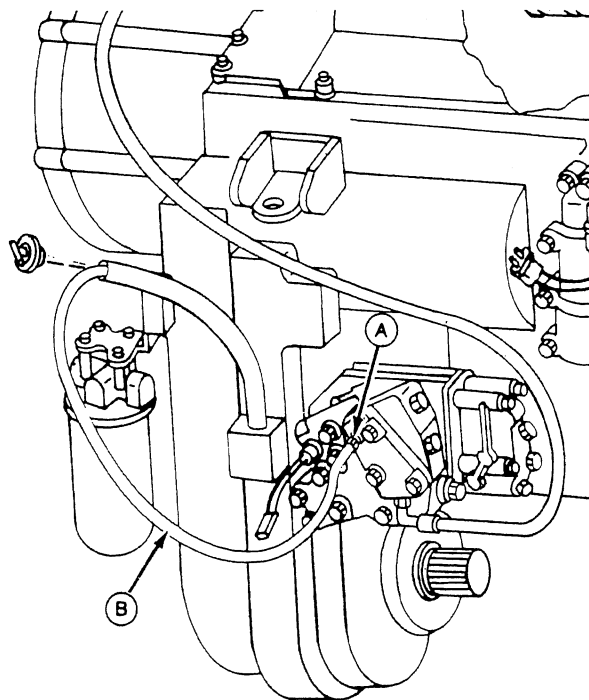

T7478AI

-UN-23MAF91

T7478AI

METRIC BOLT AND CAP SCREW TORQUE VALUES

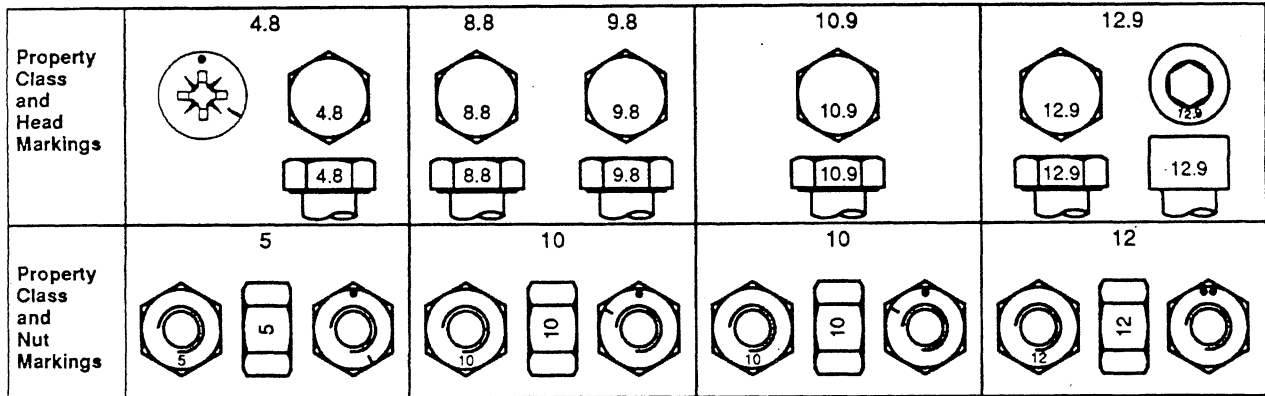

Size	Class 4.8				Class 8.8 or 9.8				Class 10.9				Class 12.9			
	Lubricated ^a		Dry ^a		Lubricated ^a		Dry ^a		Lubricated ^a		Dry ^a		Lubricated ^a		Dry ^a	
	N-m	lb-ft	N-m	lb-ft	N-m	lb-ft	N-m	lb-ft	N-m	lb-ft	N-m	lb-ft	N-m	lb-ft	N-m	lb-ft
M6	4.8	3.5	6	4.5	9	6.5	11	8.5	13	9.5	17	12	15	11.5	19	14.5
M8	12	8.5	15	11	22	16	28	20	32	24	40	30	37	28	47	35
M10	23	17	29	21	43	32	55	40	63	47	80	60	75	55	95	70
M12	40	29	50	37	75	55	95	70	110	80	140	105	130	95	165	120
M14	63	47	80	60	120	88	150	110	175	130	225	165	205	150	260	190
M16	100	73	125	92	190	140	240	175	275	200	350	225	320	240	400	300
M18	135	100	175	125	260	195	330	250	375	275	475	350	440	325	560	410
M20	190	140	240	180	375	275	475	350	530	400	675	500	625	460	800	580
M22	260	190	330	250	510	375	650	475	725	540	925	675	850	625	1075	800
M24	330	250	425	310	650	475	825	600	925	675	1150	850	1075	800	1350	1000
M27	490	360	625	450	950	700	1200	875	1350	1000	1700	1250	1600	1150	2000	1500
M30	675	490	850	625	1300	950	1650	1200	1850	1350	2300	1700	2150	1600	2700	2000
M33	900	675	1150	850	1750	1300	2200	1650	2500	1850	3150	2350	2900	2150	3700	2750
M36	1150	850	1450	1075	2250	1650	2850	2100	3200	2350	4050	3000	3750	2750	4750	3500

DO NOT use these values if a different torque value or tightening procedure is given for a specific application. Torque values listed are for general use only. Check tightness of fasteners periodically.

Shear bolts are designed to fail under predetermined loads. Always replace shear bolts with identical property class.

Fasteners should be replaced with the same or higher property class. If higher property class fasteners are used, these should only be tightened to the strength of the original.

^a "Lubricated" means coated with a lubricant such as engine oil, or fasteners with phosphate and oil coatings. "Dry" means plain or zinc plated without any lubrication.

Make sure fasteners threads are clean and that you properly start thread engagement. This will prevent them from failing when tightening.

Tighten plastic insert or crimped steel-type lock nuts to approximately 50 percent of the dry torque shown in the chart, applied to the nut, not to the bolt head. Tighten toothed or serrated-type lock nuts to the full torque value.

1 GAUGE, INDICATORS, AND CONTROL CHECKS (ENGINE OFF)

10T,9005,M518 -19-30NOV92

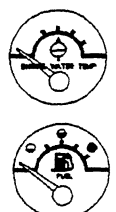
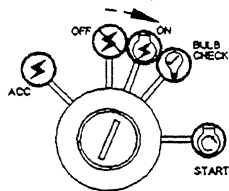
<p>GAUGE CHECK</p>	<p>Key switch OFF.</p>  <p><i>LOOK: Fuel gauge indicator needle must be to left in orange area. Engine temperature gauge indicator needle must be to left in black area.</i></p> <p>T7374AK -UN-17SEP90</p>	<p>Turn key switch to ON.</p>  <p>T7374AF -UN-27SEP90</p>
---------------------------	--	---

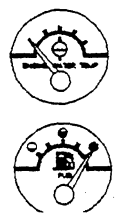
 <p>T7374AL -UN-17SEP90</p>	<p><i>LOOK: Fuel gauge indicator needle must move to right and indicate amount of fuel in tank. Engine temperature gauge indicator needle must move to right and indicate engine temperature.</i></p> <p><i>NOTE: Engine temperature gauge needle will stay in black area until engine reaches 72° C (150° F).</i></p>	<p>OK: Go to next check.</p> <p>NOT OK: Check differential lock and gauge fuses.</p> <p>IF OK: Go to your authorized dealer.</p> <p>TX,95,MM807 -19-30NOV92</p>
--	--	--

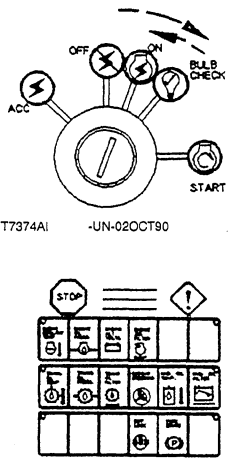
<p>MONITOR INDICATOR LIGHTS AND ALARM CHECKS</p> <p>Turn key switch to BULB CHECK position.</p>	<p><i>LOOK: All monitor indicator lights and service required indicator light must be ON. STOP indicator light must flash, and alarm must sound.</i></p> <p><i>LISTEN: Starting motor MUST NOT operate.</i></p>  <p>T7374AI -UN-02OCT90</p> <p>T7909AC -UN-14DEC92</p>	<p>OK: Go to next check.</p> <p>NOT OK: Check monitor fuses.</p> <p>IF OK: Check logic module fuse.</p> <p>NOT OK: If motor starts and bulb check position is OK, key switch failed or you have a short in wiring. Go to your authorized dealer.</p> <p>TX,95,MM808 -19-26AUG93</p>
--	---	---

4 STEERING SYSTEM CHECKS

TX.9005,WW725 -19-15APR92

STEERING SYSTEM OPERATION CHECK

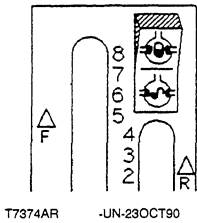
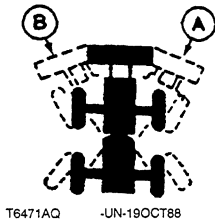

Operate engine at slow idle.

Disengage differential lock.

Turn steering wheel until frames hit the right stop (A) and then the left stop (B).

LOOK: Frames must steer smoothly in both directions. When the steering wheel is stopped, the frames must stop.

FEEL: Excessive effort MUST NOT be required to turn the steering wheel.

NOTE: If steering wheel is turned to stop and released, it is normal for wheel to rock back and forth up to 1/3 turn before stopping.

OK: Go to next check.

NOT OK: Go to your authorized dealer.

TX.95,MM827 -19-30NOV92

STEERING PRIORITY VALVE CHECK

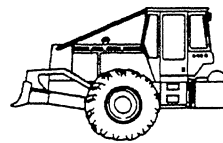
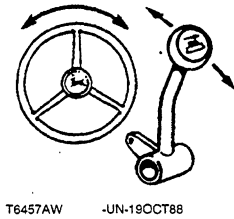

Operate engine at slow idle.

Lower blade to ground.

Steer machine frames to maximum left or right, while raising the blade.

Observe blade.

LOOK: Blade MUST NOT raise, or raise slowly until frames hit stops.

NOTE: It is normal for steering wheel to jerk or kick back if hydraulic function is moved while steering is held against stops.

OK: Go to next check.

NOT OK: Go to your authorized dealer.

TX.95,MM828 -19-26AUG93

8 WINCH CHECKS

IMPORTANT: Transmission oil must be at operating temperature for these checks.

TX,95,DH3033 -19-26AUG93

WINCH HYDRAULIC SYSTEM FUNCTIONAL CHECK

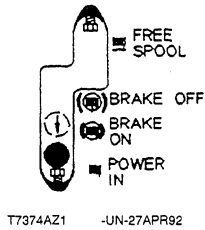

Run engine at slow idle.

Operate winch in POWER IN and FREE SPOOL position several times and observe when the drum turns each time.

Start counting the number of seconds when the lever is moved in each position.

LOOK: The normal engagement time for the winch clutch or brake disengagement is 1 second or less.

OK: Go to next check

NOT OK: If the engine stalls when the winch control lever is placed in POWER IN position with the engine at slow idle, go to your authorized dealer.

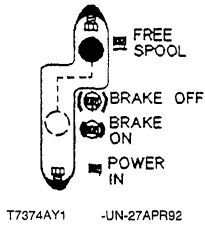

TX,95,RR,1426 -19-30NOV92

WINCH VALVE RETURN SPRING CHECK

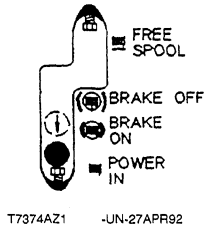

Run engine at slow idle.

Place winch control valve lever in POWER IN position and quickly release control valve lever.

Observe where the control valve lever stops.

T7374AZ1 -UN-27APR92

LOOK: The winch control valve lever must return and stop in BRAKE ON position detent.

CAUTION: Never operate a machine if the winch control valve "sticks" in POWER IN position.

OK: Go to next check

NOT OK: Inspect cable and repair. If OK, do "Brake Off" Adjustment in Maintenance chapter.

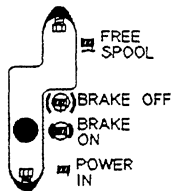

T7397AX1 -UN-27APR92

TX,95,MM859 -19-23APR92

WINCH CONTROL VALVE LINKAGE STOP CHECK

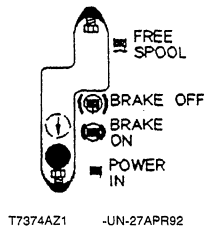

Run engine at slow idle.

Move winch control lever slowly to the POWER IN position until winch drum turns.

LOOK: Winch lever must just contact stop as winch drum starts to turn.



T7374AZ1 -UN-27APR92

Continued on next page

Operational Checkout

11 MISCELLANEOUS CHECKS

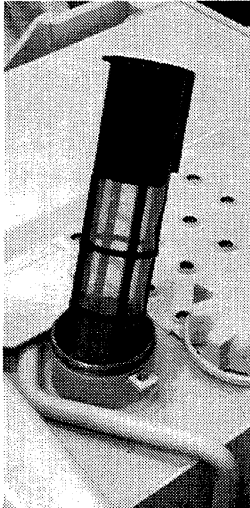
TX,95,DH3036 -19-26AUG93

<p>FUEL TANK STRAINER CHECK</p>	 <p>Remove fuel tank filler cap.</p> <p>Rotate fuel strainer to notch.</p> <p>Remove fuel strainer and inspect.</p> <p><i>LOOK: Strainer screen must be in good condition and clean.</i></p> <p>T7437AD -UN-13DEC90</p>	<p>OK: Go to next check.</p> <p>NOT OK: Clean or replace strainer.</p> <p>TX,9005,WW749 -19-26AUG93</p>
<p>ENGINE SHIELD LATCH CHECK</p>	<p>Turn handle to remove front engine side shield. <i>easily and fit tightly in place.</i></p> <p><i>LOOK/FEEL: Latch must turn freely and shield must be easily removed.</i></p> <p>Repeat check on other engine shield.</p> <p>Install shield and lock.</p> <p><i>LOOK/FEEL: Shield must install</i></p>	<p>OK: Go to next check</p> <p>NOT OK: Replace or adjust latch.</p> <p>TX,9005,WW737 -19-15APR92</p>
<p>VANDAL PROTECTION CHECK</p>	<p>Check vandal locking tabs on following components; Fuel cap, transmission dipstick door, rear engine side shields, front engine side shields, radiator door in top of grille housing, and battery box at rear of canopy.</p> <p><i>LOOK: Tabs must accept padlocks, and lock covers in place.</i></p>	<p>OK: Go to next check.</p> <p>NOT OK: Repair or replace locking tabs.</p> <p>TX,9005,WW740 -19-15APR92</p>
<p>SERVICE DECAL CHECK</p>	 <p>Remove right side engine side shield.</p> <p>Check service decal on outside of fuel filter door.</p> <p><i>LOOK: Service decal must be legible.</i></p> <p>T7437AC -UN-13DEC90</p>	<p>OK:Go to next check.</p> <p>NOT OK: Replace service decal.</p> <p>TX,9005,WW738 -19-15APR92</p>

Troubleshooting

Symptom	Problem	Solution
Oil Dripping From Turbocharger Adapter	Broken blades on turbine	See your authorized dealer.
	Damaged or worn bearings or seals	See your authorized dealer.
	Dirt entering into engine	Check vent tube to ensure tube is not clogged. Clean.
Excessive Drag In Turbocharger Rotating Members	Turbocharger oil return line carbon build-up where line passes exhaust manifold	Remove line. Inspect, clean.
	Carbon build-up behind turbine wheel caused by combustion deposits	See your authorized dealer.
	Dirt build-up behind compressor wheel caused by air intake leaks	See your authorized dealer.
	Bearing seizure or dirty or worn bearings, caused by excessive temperature, unbalanced wheel, dirty oil, oil starvation, or insufficient lubrication	See your authorized dealer.

TX.100,RR.1505 -19-28OCT93

DRIVE LINES

Symptom	Problem	Solution
Excessive Drive Line Vibration—Winch and Main	Yokes not in line on telescoping drive shafts	Inspect. See your authorized dealer.
	Worn rear drive line support bearing	Inspect. See your authorized dealer.
	Worn winch drive line support bearing	Inspect. See your authorized dealer.
	Bent drive shaft	Inspect all drive shafts. See your authorized dealer.
	Excessively worn telescoping joint or loose yoke retaining nuts	Inspect. See your authorized dealer.
	Front axle oscillating support loose	Inspect. See your authorized dealer.

TX,100,RR,1444 -19-30NOV92

Troubleshooting

Symptom	Problem	Solution
	Sticking priority valve spool or broken spring	See your authorized dealer.
	Low main hydraulic pump flow.	See your authorized dealer.
	Internal binding in steering valve or steering wheel shaft	See your authorized dealer.
	Steering relief valves set too low or leaking	See your authorized dealer.
	Steering valve anti-cavitation valves leaking	See your authorized dealer.
Erratic Steering (Spongy)	Air in system	Low oil level. Check and correct.
	Sticking priority valve spool	See your authorized dealer.
	Steering valve	See your authorized dealer.
Machine "Wanders" Or Will Not Stay In A Straight Line	Air in system	Low oil level. Check and correct.
	Leakage in steering system	See your authorized dealer.
	Broken centering spring in steering valve	See your authorized dealer.
	Steering relief valves set too low or leaking	See your authorized dealer.
	Steering valve anti-cavitation valve leaking	See your authorized dealer.

TX,100,RR,1449 -19-30SEP93

740E SKIDDER

Transmission:

The eight forward and four reverse speed direct drive powershift transmission is engineered and manufactured by John Deere specifically for skidders. The transmission charge pump is externally mounted for ease of service.

Travel Speeds:

At 2200 engine rpm, no tire slip, with 24.5L—32 tire

Forward:

	km/h	mph
1	2.7	1.7
2	3.8	2.4
3	5.8	3.6
4	7.6	4.7
5	10.1	6.3
6	13.2	8.2
7	17.0	10.6
8	29.5	18.3

Reverse:

Gear	km/h	mph
1R	3.7	2.3
2R	5.3	3.3
3R	8.1	5.0
4R	10.6	6.6

Axles:

John Deere Team Mate II axles, 1400 Series, have heavy duty inboard mounted planetary type gears that distribute shock loads evenly. Hydraulically applied differential lock in both front and rear axles is standard.

Brakes:

Hydraulic annular style wet disk brakes are inboard mounted on both front and rear axles as standard equipment. Completely sealed running in a cooling oil bath, they are self-adjusting, self-equalizing and require no periodic service. A spring applied hydraulically released wet multiple disc parking brake is transmission mounted. It is automatically applied when the engine is off. It can be manually applied by placing the transmission control lever in the park position.

Steering:

A load and speed sensing power steering system provides quick response and power for easy maneuvering for woods operations. The 90° (45° each direction) of frame articulation provides exceptional maneuverability.

Outside clearance circle with blade 12.80 m (42 ft 4 in.)

WHEN PARKING OUTDOORS

Make machines hard to move:

- Park in a well-lighted, fenced area.
- Lower all equipment to the ground.
- Remove ignition key.
- Remove battery when unit is storage.
- Lock cab doors, windows, and vandal-proof devices.

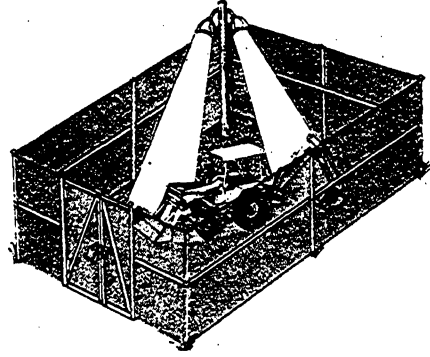

DX,CRPRV,K -19-04JUN90

TS144
-UN-23AUG88

REDUCE VANDALISM

1. Install vandal-proof devices.
2. Participate in a neighborhood watch program. Take written notes of suspicious vehicles or persons and report your findings to law enforcement agency.
3. Regularly verify that identification plates have not been removed. If they have, notify law enforcement agency. Order duplicate plates from your dealer.

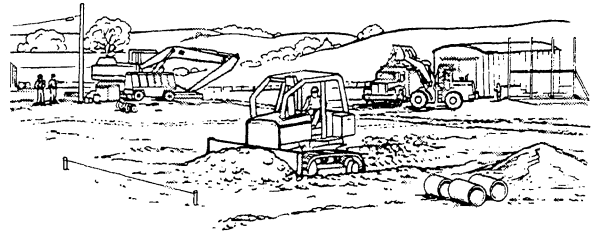

TX,110,RR,671 -19-28JUN90

T7223BB
-UN-22FEB90

REPORT THEFTS IMMEDIATELY

1. Immediately notify your local law enforcement agency and insurance agent.
2. Provide a complete description of the machine, all of the documented identification numbers and color photographs.
3. Request verification of the identification numbers after they have been entered with any regional or national crime information center. Double check the numbers to be sure they are correct.
4. Notify your John Deere dealer of the theft and request that its loss be posted with full description and identification numbers.



DX,CRPRV,G -19-03MAR93

TS146
-UN-09JAN89

CLICK HERE TO **DOWNLOAD** THE COMPLETE MANUAL

- Thank you very much for reading the preview of the manual.
- You can download the complete manual from: www.heydownloads.com by clicking the link below



- Please note: If there is no response to CLICKING the link, please download this PDF first and then click on it.

CLICK HERE TO **DOWNLOAD** THE COMPLETE MANUAL