

# JOHN DEERE 415 B, 515 B BACKHOE LOADER



JOHN DEERE

## OPERATORS MANUAL JOHN DEERE 415 B, 515 B BACKHOE LOADER

OMCD16146 D4 English

JOHN DEERE SARAN  
OMCD16146 D4

LITHO IN THE U.S.A.  
ENGLISH



OMCD16146 D4



OMCD16146 D4

CLICK HERE TO **DOWNLOAD** THE COMPLETE MANUAL

- Thank you very much for reading the preview of the manual.
- You can download the complete manual from: [www.heydownloads.com](http://www.heydownloads.com) by clicking the link below



- Please note: If there is no response to CLICKING the link, please download this PDF first and then click on it.

CLICK HERE TO **DOWNLOAD** THE COMPLETE MANUAL

# Safety

## AVOID FIRE HAZARDS

Be prepared if an accident or fire should occur. Know where the first aid kit and the fire extinguishers are located—know how to use them.

Do not smoke while refueling or handling highly flammable material.

Shut off the engine when refueling.

Use care in refueling if the engine is hot.

Do not use open pans of gasoline or diesel fuel for cleaning parts. Use good commercial, nonflammable solvents.

Provide adequate ventilation when charging batteries.

Do not check battery charge by placing metal objects across the posts.

Do not allow sparks or open flame near batteries.

Do not smoke near battery.

Never check fuel, battery electrolyte, or coolant levels with an open flame.

Never use an open flame to look for leaks anywhere on the equipment.

Never use an open flame as light anywhere on or around the equipment.

When preparing engine for storage, remember that inhibitor is volatile and therefore dangerous. Seal and tape openings after adding the inhibitor. Keep container tightly closed when not in use.

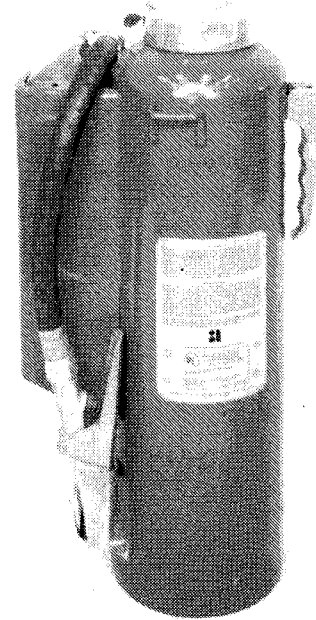

63A:T86875 T82;BHS A B 010283

## UNDERSTAND MACHINE OPERATION

Only qualified people should operate the machine.

Learn the location and purpose of all controls, instruments, indicators, and labels.



63A:T88892 T82;BHS A C 250183

## PEDALS

A—Clutch  
B—Brakes  
C—Speed Control

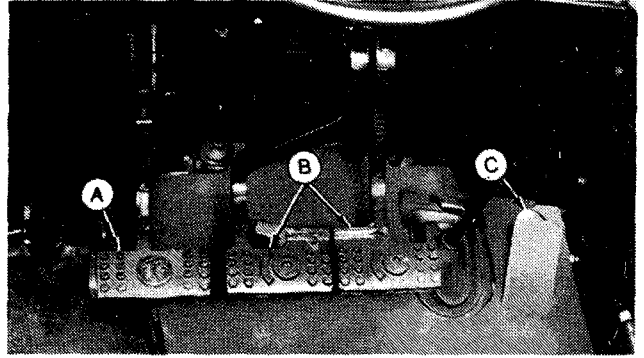

D—Differential Lock  
E—MFW D (if equipped)

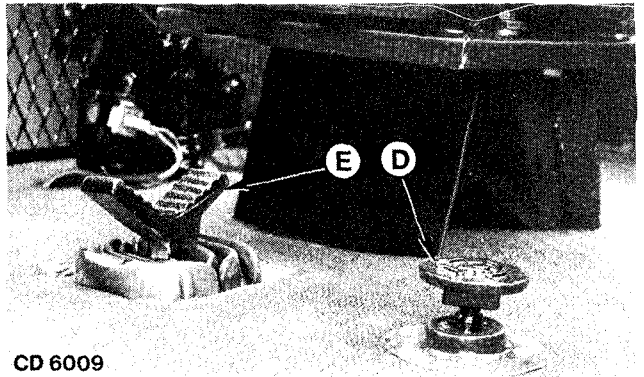

CD 6009

F—Extendable Dipperstick  
(if equipped)

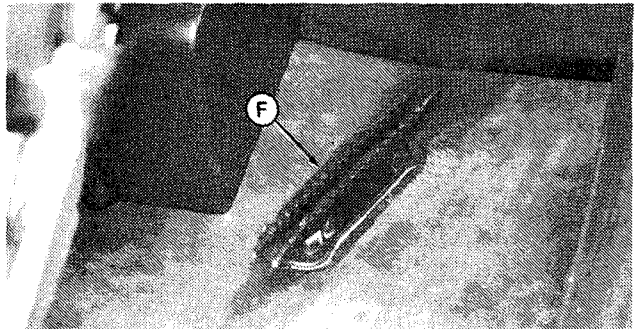

T87449, CD6009, T86881-415BACDE-250983

## BACKHOE CONTROLS

A—Left Stabilizer Control Lever  
B—Right Stabilizer Control Lever  
C—Boom Control Lever  
D—Dipperstick and Bucket Control Lever  
E—Sliding Frame Lock Pedal

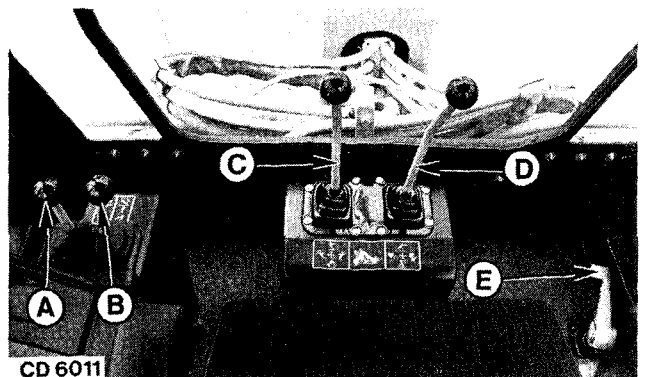

CD 6011

CD6011-415BACDE-250983

# Operating The Engine

**IMPORTANT:** If the engine is to be run for a short time without battery (using a slave battery for starting), do not, under any circumstances, interrupt the circuit by switching off the main switch before stopping the engine by means of the fuel injection pump shut-off

cable. Do not raise engine speed above 1000 rpm. Furthermore, use additional current (lights) while engine is running. Insulate battery end of disconnected starter cable properly to avoid damage to both alternator and regulator.

MOTOM-1640ALE-120183

## STARTING THE ENGINE

**CAUTION:** Avoid possible injury or death from a runaway machine. Do not start engine by shorting across starter terminals. Machine will start in gear and move if normal starting circuitry is bypassed. Start engine only from operator's seat with transmission in neutral. NEVER start engine while standing on ground.

**IMPORTANT:** After a false start, do not push start switch until engine stops.

**NOTE:** Reverser lever must be locked in neutral or engine will not start.

1. Move gear shift lever (c) to neutral "N".
2. Move reverser lever (A) to neutral.
3. Turn lock lever (B) to lock reverser lever in neutral.
4. Move parking brake lever (D) up to engage brake.

A—Reverser Lever  
B—Lock Lever

C—Gear Shift Lever  
D—Parking Brake Lever

5. Move speed control lever (A) to one-third speed position.
6. Turn key (B) clockwise to ON.
7. Push starter button (C) to start engine. Release button as soon as engine starts or after 20 seconds if engine does not start. Wait 2 minutes before you try to start engine again.
8. Move speed control lever to half-speed position.

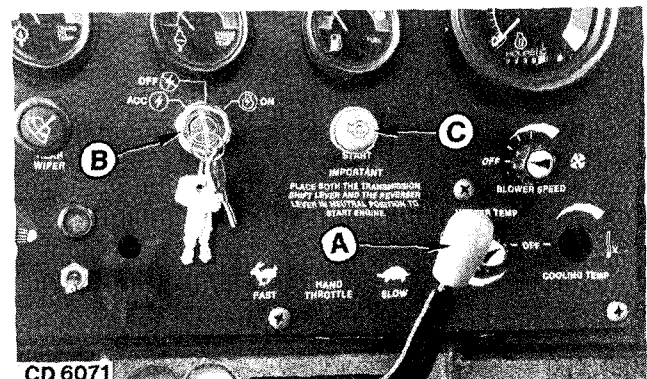
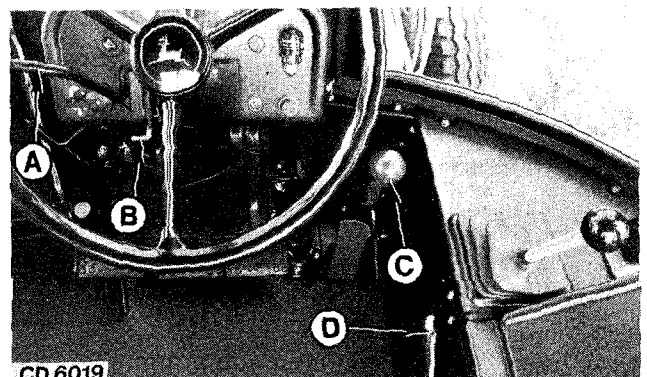
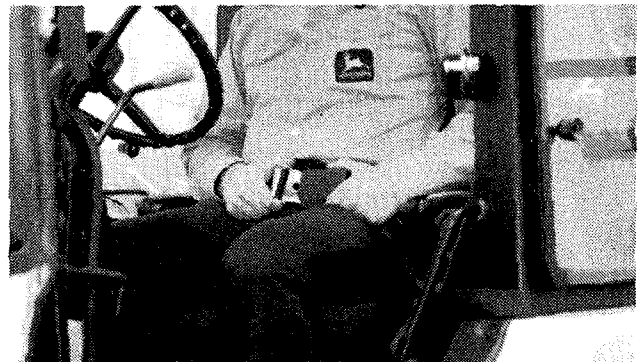

T88900,CD6019,CD6071-415BACDE-250983

## SHIFTING THE MULTI-POSITION BACKHOE

1. Lower stabilizers.
2. Swing boom in opposite direction of shift.
3. Extend bucket cylinder and lower bucket to the ground so that teeth hold firmly.
4. Unlock sliding frame by depressing pedal (A). Hold the pedal in this position.
5. Push in direction desired, using boom and dipperstick lever.
6. Lock sliding frame. Release the pedal (A).

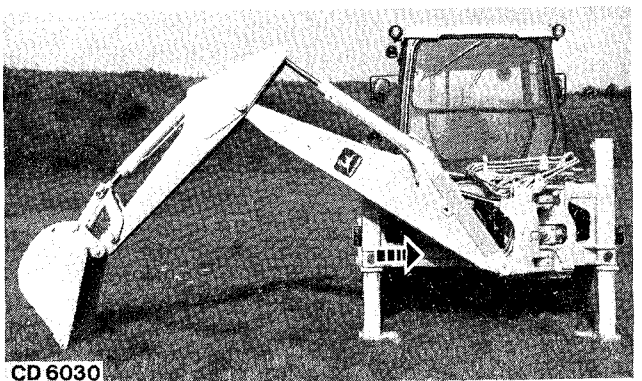
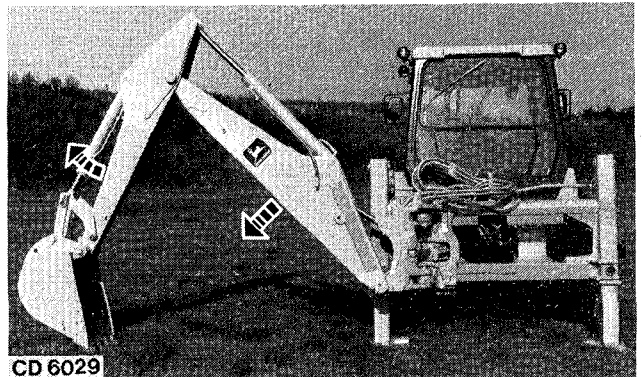
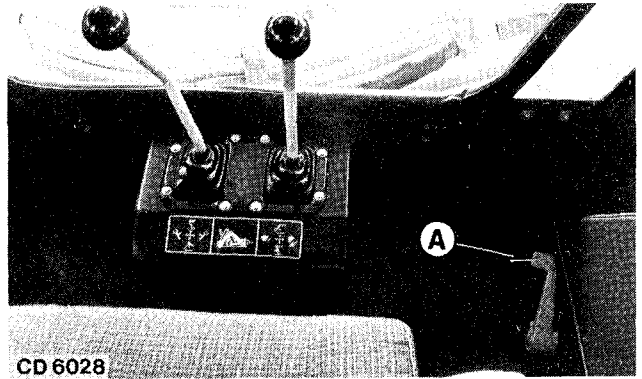
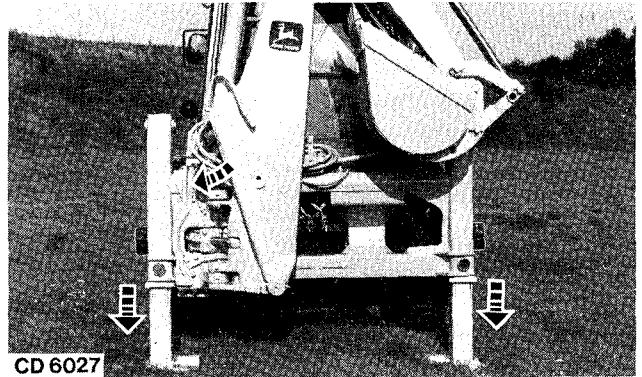

CLICK HERE TO **DOWNLOAD** THE COMPLETE MANUAL

- Thank you very much for reading the preview of the manual.
- You can download the complete manual from: [www.heydownloads.com](http://www.heydownloads.com) by clicking the link below



- Please note: If there is no response to CLICKING the link, please download this PDF first and then click on it.

CLICK HERE TO **DOWNLOAD** THE COMPLETE MANUAL

## Operating the Machine

4. If distance between hook and stop is not correct, loosen lock nut.
5. Remove nut (A) to disconnect ball joint from bellcrank.
6. Turn ball joint until distance between hook and stop is 79 mm (3.1 in.).
7. Connect ball joint to bellcrank with nut (A).
8. Tighten lock nut.

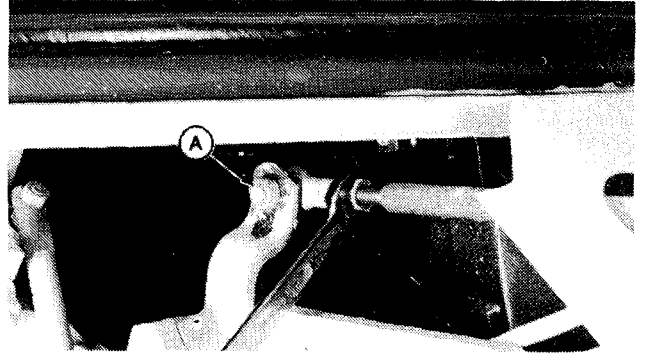

63A;T87481 T82;BHOM AN 020283

# Periodic Maintenance/Regularly

## SERVICE YOUR MACHINE AT SPECIFIED INTERVALS

Lubricate, make service checks and adjustments at intervals shown on the periodic maintenance chart and on the following pages.

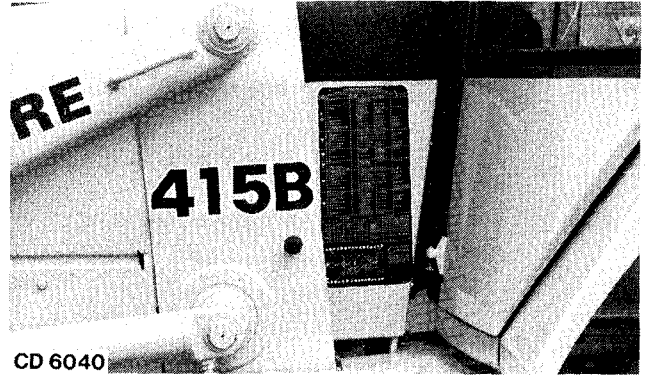

CD 6040

CD6040-415BACDE-250983

## CHECK THE HOUR METER REGULARLY

Check the hour meter (A) to determine when your machine needs periodic maintenance.

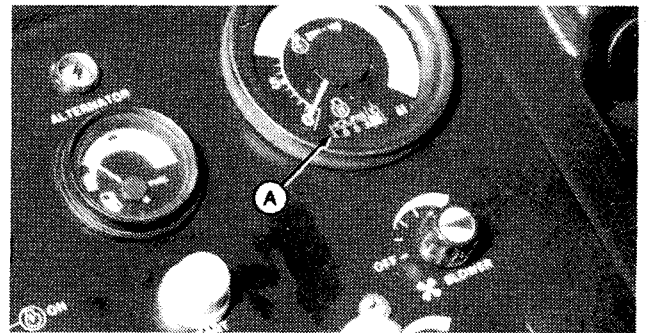

63A:T88888 T82;BHPM B 250183

## OPEN ENGINE SHIELD

**IMPORTANT:** To prevent damage to shield, do not drive machine or operate loader with shield removed.

1. Turn handle to release shield.

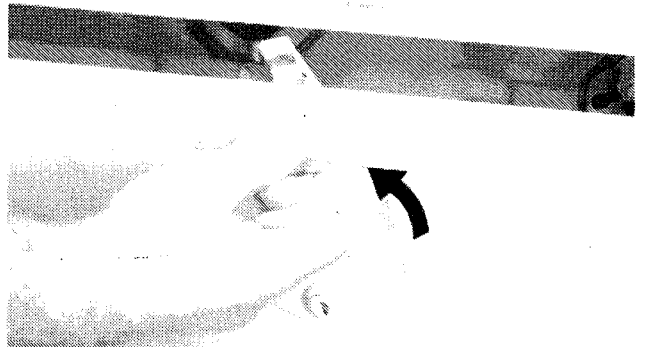

2. Lift shield to remove it.

3. Let shield hang by cable.

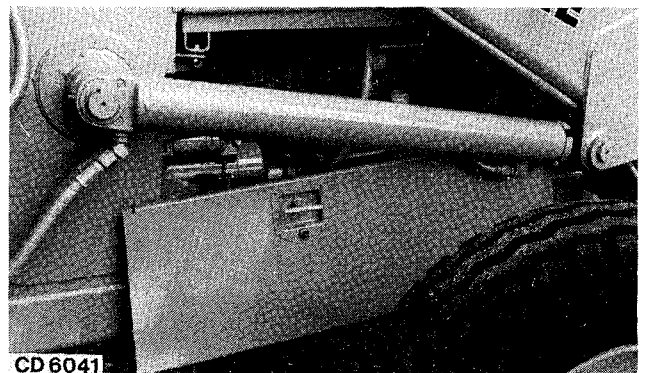

CD 6041

T86931,CD6041-415BACDE-250983

## CHECK TRANSAXLE-HYDRAULIC OIL LEVEL

1. Park the backhoe loader on level surface.
2. Put transmission in neutral, engage parking brake and lock reverser lever in neutral.

**IMPORTANT:** If machine has not been operated for 3 hours or more, check oil level with the engine off prior to starting. If machine is warmed to normal operating temperature, run engine at slow idle 3 minutes, then check oil level with engine running.

3. Lower loader bucket to ground.
4. Put backhoe in transport position, raise stabilizers.
5. Open loader control valve cover.
6. Turn dipstick handle counterclockwise to loosen it. Remove dipstick (A).

Oil level must be between marks on dipstick.

If oil level is low (below bottom mark), add oil specified in Fuels, Lubricants and Coolant chapter.

Install dipstick. Tighten handle.



CD 6047

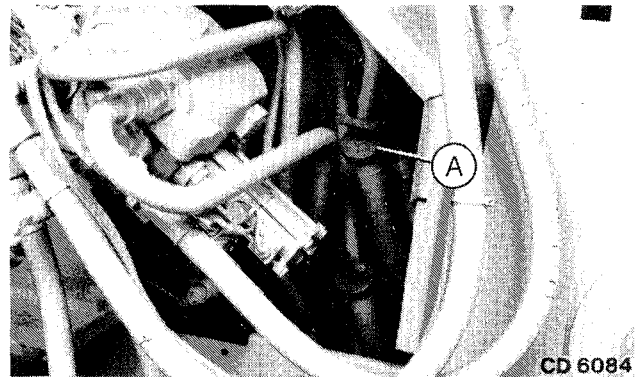

CD 6084

# Periodic Maintenance/1000 Hours

## CLEAN FUEL TRANSFER PUMP STRAINER "SOFABEX"

- 1 - Remove bowl (A).
- 2 - Remove strainer and wash in fuel (B).
- 3 - If damaged, replace bowl gasket (C).  
Clean bowl.
- 4 - Replace strainer and install bowl.

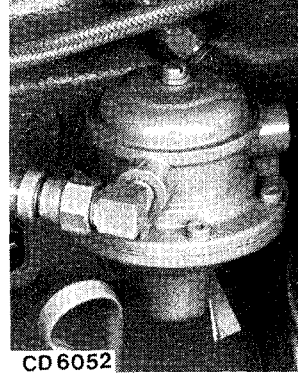

CD 6052

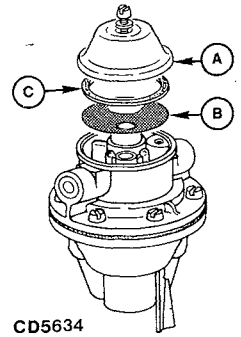

CD 5634

CD6052, CD5643-415BACDE-250983

## CLEAN FUEL TRANSFER PUMP STRAINER "CORONA"

- 1 - Disconnect fuel lines.
- 2 - Remove cover screws (A) and cover.
- 3 - Gently tap the cover to remove base and screen.
- 4 - Remove screen and wash in fuel, replace if damaged.
- 5 - Install base and screen in pump cover.
- 6 - Install cover and cover screws.
- 7 - Connect fuel lines.

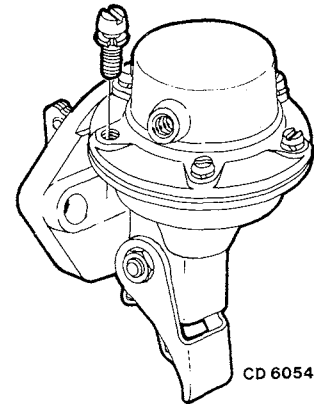

CD 6054

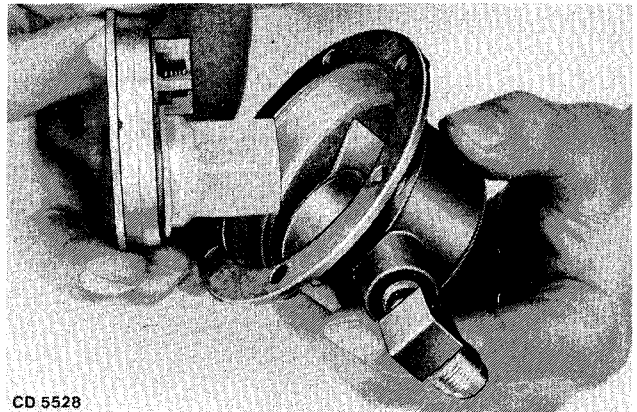

CD 5528

CD6054, CD5528-415BACDE-250983

# Troubleshooting

## ENGINE

Problem	Cause	Solution	Page
<b>Engine hard to start, will not start</b>	Wrong fuel.	Use correct fuel.	45-1
	Fuel shut-off valve closed. Low battery power.	Open valve. Charge or install new battery.	60-1
	Plugged line or nozzle on starting fluid adapter.	Clean line or nozzle.	60-2
	Resistance in starting circuit.	Clean and tighten battery and starter connections.	60-1 60-2
	Wrong engine oil.	Use correct oil.	45-2
	Water, dirt, or air in fuel system.	Remove air from fuel system. Clean fuel tank strainer.	50-18
	Injection nozzles dirty or not working correctly.	See your John Deere dealer	
	Plugged fuel filter.	Change element	50-11
	Leaks in fuel system.	Check fuel system connections.	
	Air locked in fuel system.	Remove air from fuel system.	50-18
	Injection pump solenoid disconnected	Connect wire	
<b>Engine knocks, runs irregularly or stops</b>	Engine oil low.	Add oil	50-10
	Plugged air intake system.	Clean filter and system.	50-3
	Injection pump out of time.	See your John Deere dealer.	
	Plugged fuel filter.	Change element.	50-18
	Low coolant temperature.	Thermostat not working correctly or too "cool". See your John Deere dealer.	
	Water, dirt, or air in fuel system.	Remove air from fuel system. Clean fuel tank.	60-3 50-7
	Injection nozzles dirty or faulty.	See your John Deere dealer	

### INSTALLING RIPPER TOOTH

For work in frozen ground, asphalt, or tree roots, remove the backhoe bucket. Install the ripper tooth with bucket pins (A).

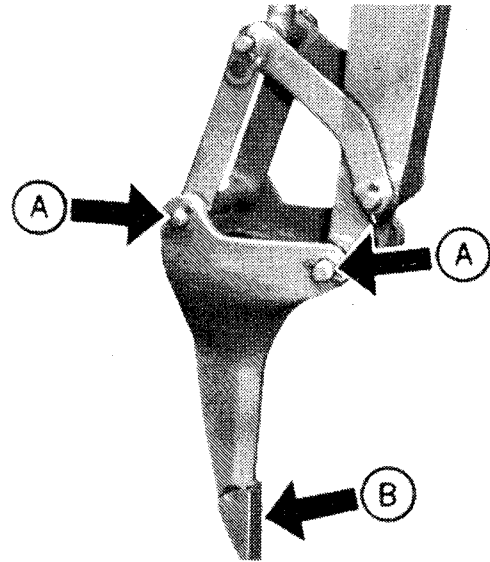

To install new tip (B):

1. Remove old tip.
2. Install new tip.
3. Stake both sides.

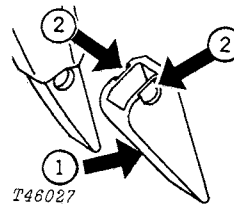

63A;T46293, T46027 T82;8HMA 0 270882

### INSTALLING LOADER BUCKET TEETH

To install a new tooth tip:

1. Drive out the pin (A).
2. Remove the tooth tip (B).
3. Install a new tip.
4. Install a new pin if the old one is worn.

If a tooth shank (C) is loose, tighten the lock nuts (D) on the cap screw (E) and plow bolt (F). If this does not tighten the shank, install a new cap screw and a new plow bolt.

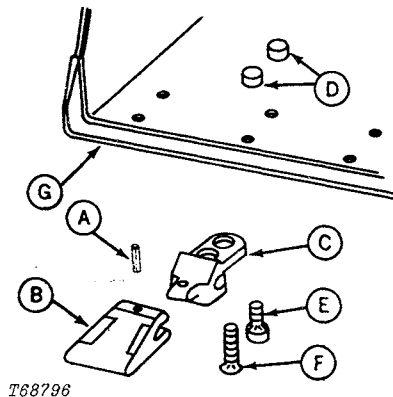

- |               |                |
|---------------|----------------|
| A—Pin         | E—Cap Screw    |
| B—Tooth Tip   | F—Plow Bolt    |
| C—Tooth Shank | G—Cutting Edge |
| D—Lock Nut    |                |

63A;T68796 T82;8HMA P 270882

CLICK HERE TO **DOWNLOAD** THE COMPLETE MANUAL

- Thank you very much for reading the preview of the manual.
- You can download the complete manual from: [www.heydownloads.com](http://www.heydownloads.com) by clicking the link below



- Please note: If there is no response to CLICKING the link, please download this PDF first and then click on it.

CLICK HERE TO **DOWNLOAD** THE COMPLETE MANUAL