

# 210C Landscape Loader



JOHN DEERE

## OPERATORS MANUAL 210C Landscape Loader

OMT148914 E3 English

**John Deere Dubuque Works**

**OMT148914 E3**

(This manual replaces OMT142945 L1)

LITHO IN U.S.A.  
ENGLISH

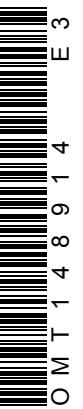

CLICK HERE TO **DOWNLOAD** THE COMPLETE MANUAL

- Thank you very much for reading the preview of the manual.
- You can download the complete manual from: [www.heydownloads.com](http://www.heydownloads.com) by clicking the link below



- Please note: If there is no response to CLICKING the link, please download this PDF first and then click on it.

CLICK HERE TO **DOWNLOAD** THE COMPLETE MANUAL



## PREVENT MACHINE RUNAWAY

Avoid possible injury or death from machinery runaway.

Do not start engine by shorting across starter terminals. Machine will start in gear if normal circuitry is bypassed.

NEVER start engine while standing on ground. Start engine only from operator's seat, with transmission in neutral or park.

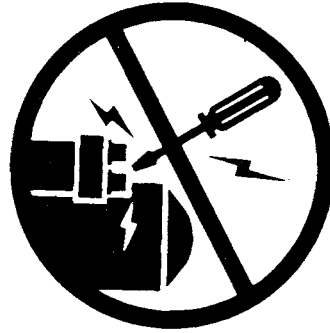

DX,BYPAS1 -19-03MAR93

TS177 -UN-11JAN89

## USE SEAT BELT PROPERLY

Use a seat belt when you operate with a roll-over protective structure (ROPS) or cab to minimize chance of injury from an accident such as an overturn.

Do not use a seat belt if operating without a ROPS or cab.

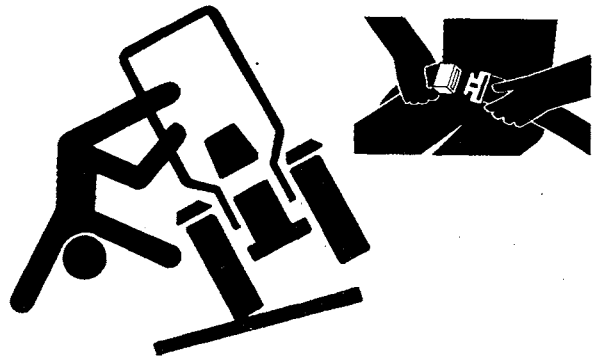

DX,ROPS1 -19-03MAR93

TS205 -UN-23AUG88

## MAINTAIN SEAT BELT

It is important to use the seat belt on ROPS equipped machines to minimize the chance of injury from an accident such as an overturn. Keep the seat belt in good condition.

Carefully examine buckle, webbing, and attaching hardware.

Be sure that the retractor, if equipped, locks to prevent belt extension after latching buckle.

Be sure that attaching hardware is in place. Tighten, if necessary.

**Replace the seat belt if it does not operate properly, or if it is damaged, worn, or deteriorated.**



TX,05,RR2936 -19-15MAR93

T7931AU -UN-22FEB93



## REMOVE PAINT BEFORE WELDING OR HEATING

Avoid potentially toxic fumes and dust.

Hazardous fumes can be generated when paint is heated by welding, soldering, or using a torch.

Do all work outside or in a well ventilated area. Dispose of paint and solvent properly.

Remove paint before welding or heating:

- If you sand or grind paint, avoid breathing the dust. Wear an approved respirator.
- If you use solvent or paint stripper, remove stripper with soap and water before welding. Remove solvent or paint stripper containers and other flammable material from area. Allow fumes to disperse at least 15 minutes before welding or heating.

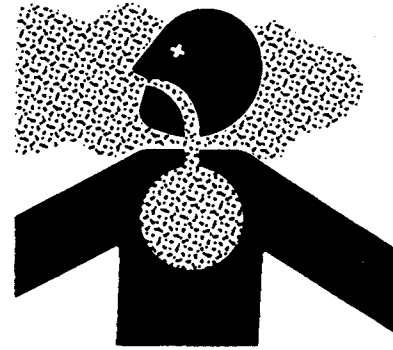

DX,PAINT -19-03MAR93

TS220 -UN-23AUG88

## AVOID HEATING NEAR PRESSURIZED FLUID LINES

Flammable spray can be generated by heating near pressurized fluid lines, resulting in severe burns to yourself and bystanders. Do not heat by welding, soldering, or using a torch near pressurized fluid lines or other flammable materials. Pressurized lines can be accidentally cut when heat goes beyond the immediate flame area.



DX,TORCH -19-03MAR93

TS963 -UN-15MAY90

# Operator's Station

## INSTRUMENT PANEL

**IMPORTANT:** When the stop indicator is activated, stop engine immediately and investigate cause of problem. DO NOT start engine until problem has been corrected.

The stop indicator (U) and audible alarm (S) are activated (intermittent) every time the engine oil pressure, engine coolant temperature, or park brake sender is activated.

**IMPORTANT:** When caution indicator is activated, a problem is developing. It is not necessary to stop the engine immediately, but the cause should be investigated as soon as possible.

The caution indicator (T) is activated every time the engine alternator volts, reverser oil temperature, or hydraulic filter restriction sender is activated.

- |  |                           |
|--|---------------------------|
| A—Front Wiper Switch                         | I—Park Brake Indicator    |
| B—Rear Wiper Switch                          | J—Fuel Gauge              |
| C—Start Aid Switch*                          | K—Hour Meter**            |
| D—Engine Oil Pressure Indicator              | L—Blower Switch           |
| E—Engine Coolant High Temperature Indicator  | M—Heater Control          |
| F—Engine Alternator Low Voltage Indicator    | N—Speed Control Lever     |
| G—Reverser Oil High Temperature Indicator    | O—Horn Switch             |
| H—Hydraulic Oil Filter Restriction Indicator | P—Key Switch              |
|  | Q—Rotating Beacon Switch* |
|  | R—Light Switch            |
|  | S—Audible Alarm           |
|  | T—Caution Indicator       |
|  | U—Stop Indicator          |
|  | V—PTO Switch*             |

\*If equipped

\*\*Tachometer-If equipped

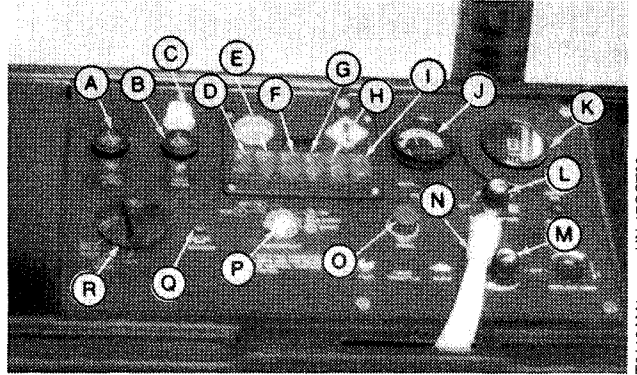

T6118AM1 -UN-17OCT88

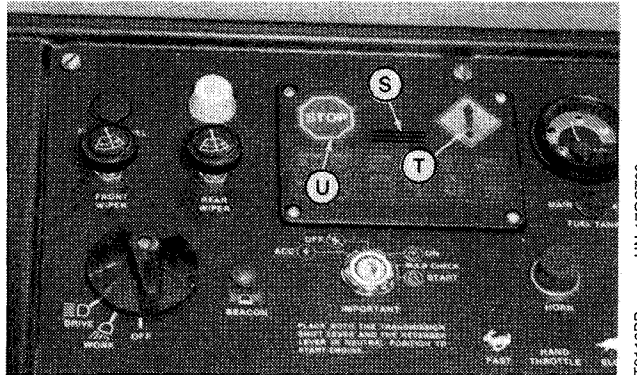

T6118BB -UN-17OCT88

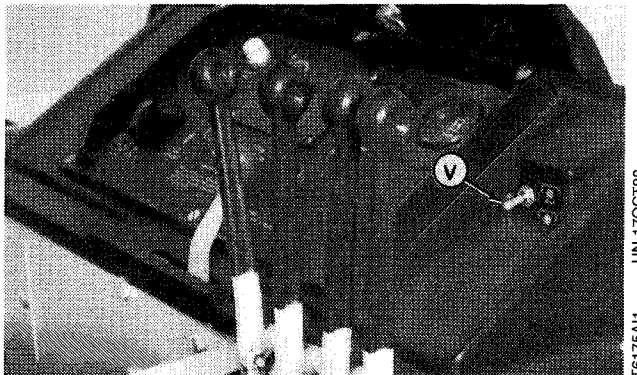

T6175A11 -UN-17OCT88

T82,BHOS,DG -19-20MAY93

## SEAT LOCK CONTROLS—SUSPENSION SEAT

**⚠ CAUTION: A loose seat or a seat not properly locked in position can cause loss of control of machine and injuries. Be sure seat is locked in position before operating machine.**

1. Move fore-aft lever (A) to left.
2. Push seat to desired position and release lever to lock seat.
3. Push turn-around lever (B) back.
4. As you turn seat, release lever to lock seat when it is completely turned around.

**⚠ CAUTION: Seat will go down rapidly and can strike and injure legs when adjusting for operator's comfort. DO NOT put your full weight on seat while adjusting for height.**

5. Lift seat until you feel the next detent to raise height of seat.
6. Lift past second detent and let it back down to bottom of travel to lower seat.
7. With NO weight on seat, turn knob (E) until indicator (D) reads operator's weight.
8. To adjust seat turn-around tension, remove plastic rivets (C) and pull down pleated rubber cover.
9. Remove lock nut (G) and washer. Tighten or loosen nut (F) until desired tension is obtained.

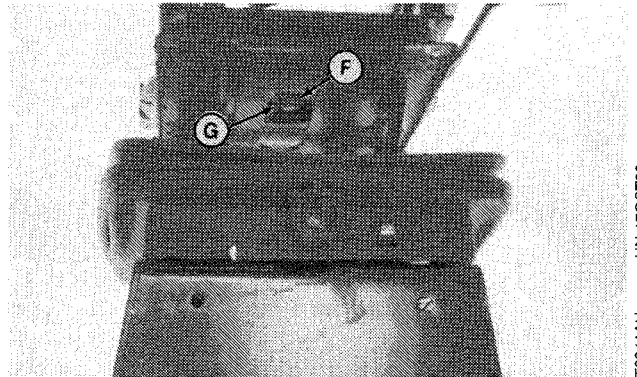
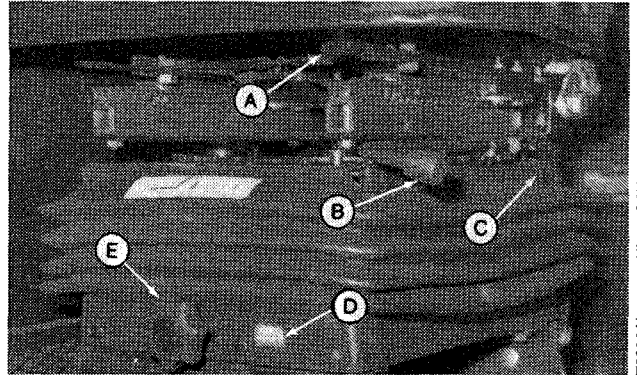

- A—Fore-Aft Lever
- B—Turn-Around Lever
- C—Rivets
- D—Weight Indicator Knob
- E—Weight Adjustment
- F—Nut
- G—Lock Nut

### ADJUST CAB DOOR LATCH

Install shims (A) as required for proper engagement of latch to striker (B).

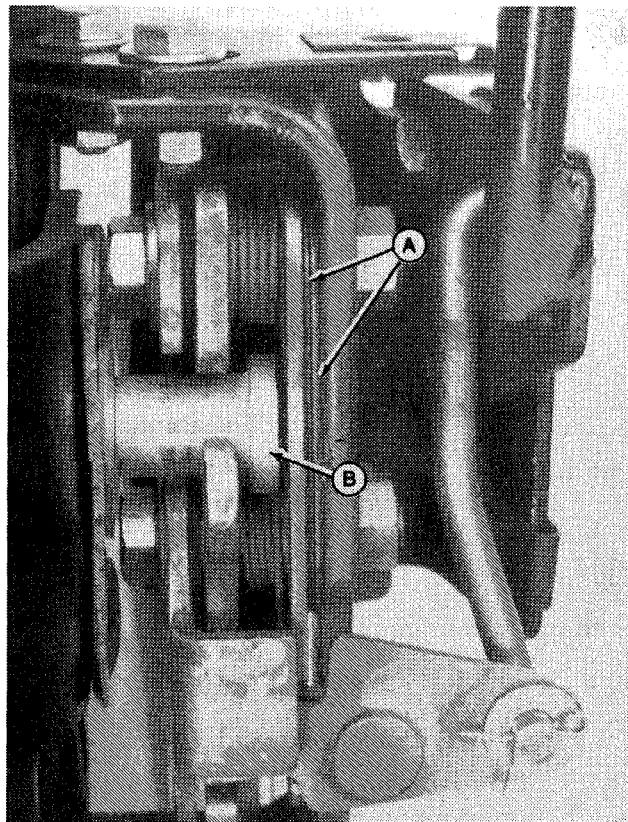

T82,BHOS,CX -19-14MAR90

T92274 -UN-19OCT88

### HEATER CONTROLS

1. Turn temperature knob (A) clockwise to increase temperature.
2. Turn blower knob (B) clockwise to any of three speeds.

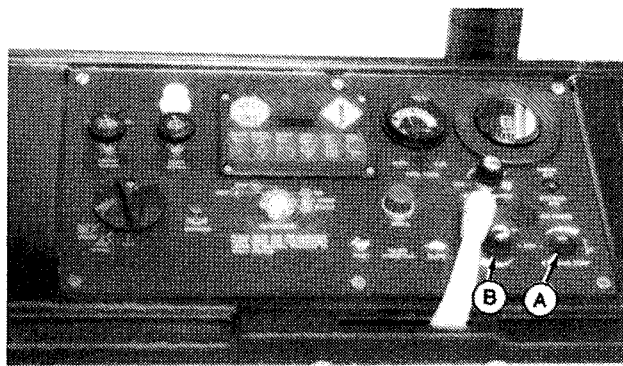

TX,10,DS4731 -19-20MAY93

T7975AF -UN-08APR93

### VANDAL SHIELD

The shield covers the instrument panel and locks with the ignition key.



T82,BHOS,BZ -19-03DEC91

T6003AA -UN-17OCT88

**USING COOLANT HEATER—IF EQUIPPED**

**⚠ CAUTION:** Prevent possible injury from fire from an overheated electrical cord. Use a heavy-duty, grounded cord to connect heater to electrical power.

Connect the coolant heater to 115-volt electrical power 10 hours before you start the engine.

T82,25,C53 -19-03DEC91

**CHECKING INSTRUMENTS AFTER STARTING**

**IMPORTANT:** If a gauge or indicator light does not operate as shown below, **IMMEDIATELY STOP THE ENGINE.** Find and correct the problem.

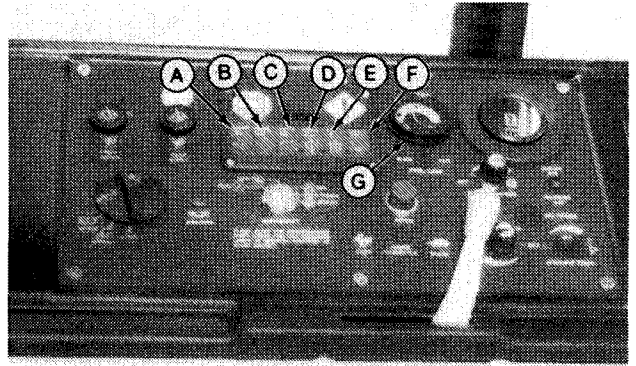

T6118AM2 -JUN-17OCT88

Gauge or Indicator Light	Immediately After Starting	Normal Operation After Warm-Up
A—Engine Oil Low Pressure Indicator . . . . .	Off** . . . . .	Off
B—Engine Coolant High Temperature Indicator . . . . .	Off . . . . .	Off
C—Engine Alternator Low Voltage Indicator . . . . .	Off . . . . .	Off
D—Reverser Oil High Temperature Indicator . . . . .	Off . . . . .	Off
E—Hydraulic Oil Filter Restriction Indicator . . . . .	Off . . . . .	Off
F—Park Brake Indicator . . . . .	Off . . . . .	Off*
G—Fuel Level Gauge . . . . .	Green Zone . . . . .	Green Zone

\*Park brake indicator light will come on and stop indicator will flash if direction selector lever is moved to forward or reverse position while park brake is engaged.

\*\*It is normal for engine oil pressure indicator light to come on at start-up and stay on for a few seconds.

02T,25,K39 -19-03DEC91

## BACKHOE BOOM, BUCKET, DIPPERSTICK, AND SWING CONTROL LEVERS—JOHN DEERE PATTERN

**CAUTION:** Prevent possible injury from unexpected machine movement if you are not in the operator's seat when operating the machine. **DO NOT** operate backhoe unless you are in the operator's seat facing the backhoe.

**IMPORTANT:** When you swing the boom, do not hit stabilizer cylinder with boom.

For faster cycle times:

- Move boom, dipperstick, and bucket at the same time.
- Move lever as far as it will move for a function.
- Run engine at fast idle.

A—Lower Boom  
B—Raise Boom  
C—Boom Left  
D—Boom Right

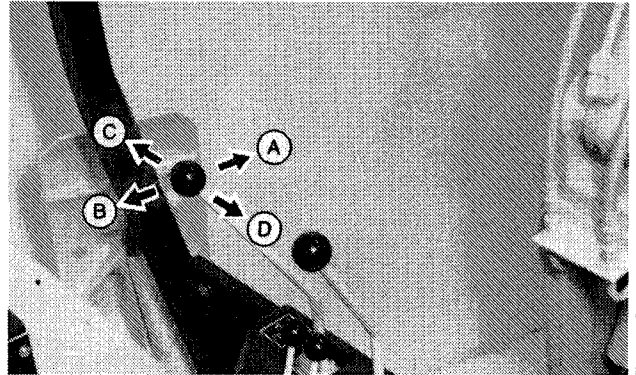

T5985AC2 -UN-17OCT88

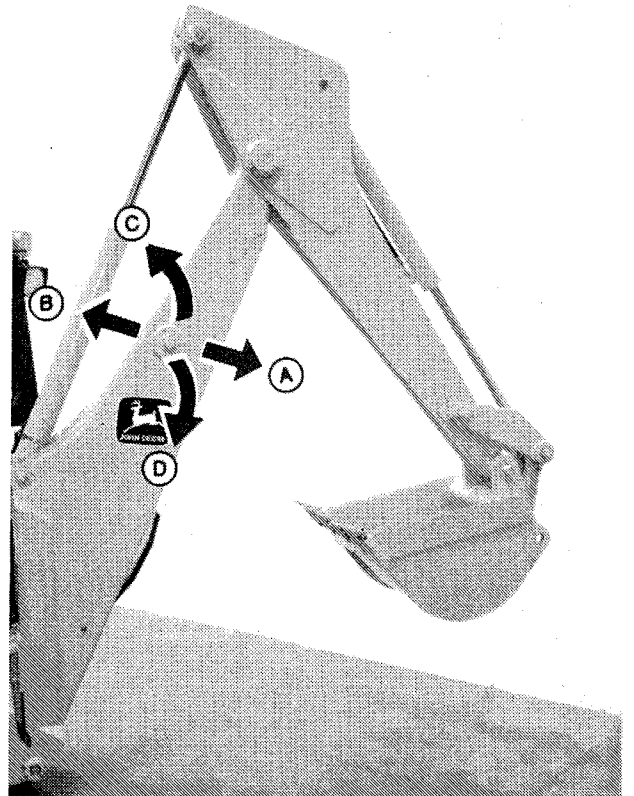

T7593AT -UN-07OCT91

TX,35,RR,2020 -19-03DEC91

## OPERATING POWER TAKE-OFF (PTO)—IF EQUIPPED

**⚠ CAUTION:** Prevent possible injury from rotating PTO shaft. Keep hands, feet, and clothing away from rotating shaft. Before you clean PTO equipment or adjust the hitch, disengage PTO and stop engine. Engage PTO only when the engine is running.

**NEVER** enter the operator's station from rear of unit. Clothing can become caught in moving PTO parts.

A bar restricts entry from rear of operator's station. Do not use bar as a handrail.

When you are not using the PTO, disconnect equipment from the power shaft.

1. Pull out switch and move it up to engage PTO (A) and down to disengage PTO (B).

*NOTE: PTO power shaft may slow or stop, when the loader controls are being used.*

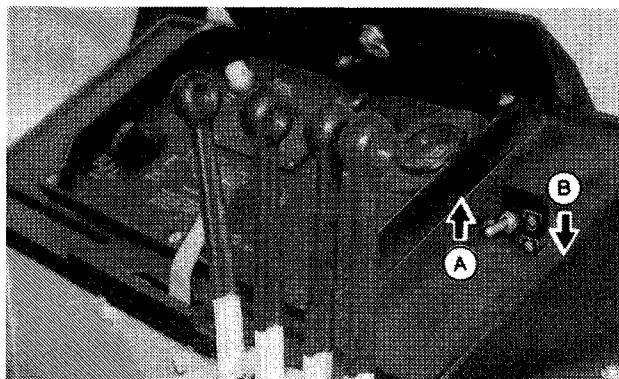

TX,35,RR,2047 -19-03DEC91

2. When PTO equipment is under a load, pointer on tachometer (A) must be at 2000 rpm to operate PTO at 540 rpm.

If attached equipment is made to be run at other PTO speeds, read the operator's manual for that equipment.

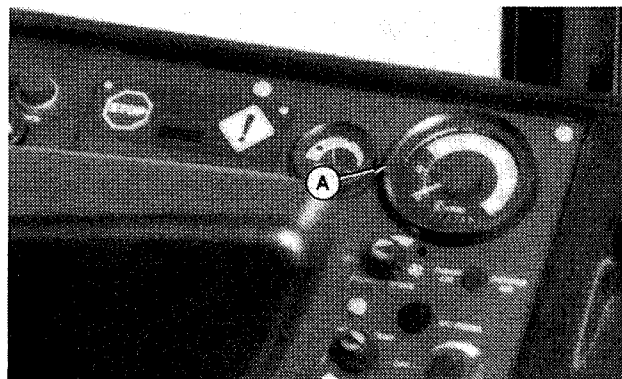

T82,BHOM,EC -19-04SEP85

## Operating the Machine

Work perpendicular to or at an angle to the stockpile to prevent stockpile above machine collapsing onto machine. Use backhoe bucket to remove material that may fall onto machine.

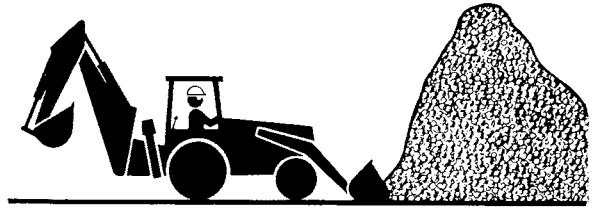

TX,35,FF1106 -19-22FEB90

T7208AA -JUN-30JAN90

To prevent cave-in's, work perpendicular to or at an angle to excavation. Do not drive near the edge of an excavation or trench.

The backhoe bucket can also be used to fill in excavated areas where cave-in's might occur.



TX,35,FF1107 -19-22FEB90

T7208AB -JUN-30JAN90

### DRIVING ON A SLOPE

**⚠ CAUTION: Prevent possible injury from machine rollover. DO NOT turn on slopes.**

Driving up or down slope WITH load in bucket:

- Lower backhoe bucket near to ground and retract dipperstick.
- Lower loader bucket near to ground.
- Point loader bucket up slope and slowly drive vertically up slope.

Driving up or down slope WITHOUT load in bucket:

- Lower backhoe bucket near to ground and retract dipperstick.
- Lower loader bucket near to ground.
- Point loader bucket down slope and slowly drive vertically down slope.

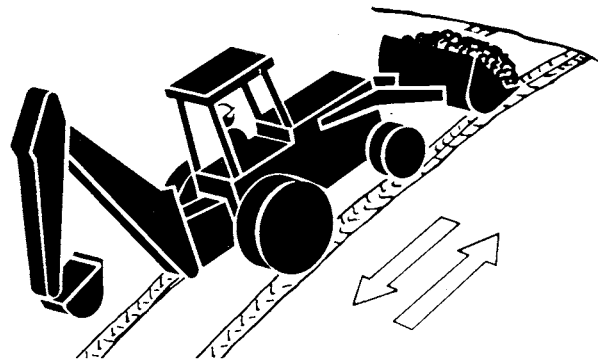

T7208AD -JUN-19FEB90

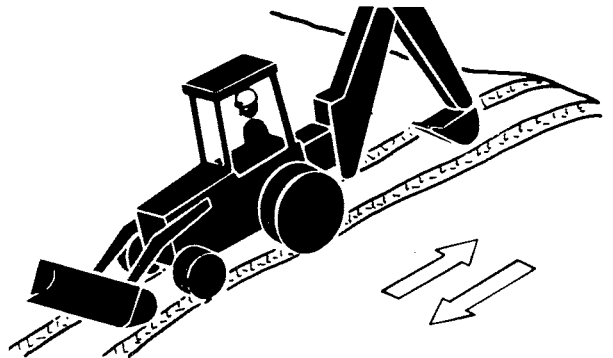

T7208AC -JUN-19FEB90

TX,35,DH1547 -19-17NOV90

## BENCHING

Before starting work, walk the site to uncover hazards and to plan the job.

**⚠ CAUTION: Prevent possible injury from a collapsing soil bank. DO NOT undercut soil bank with bucket.**

Start benching on a level surface. If necessary, use backhoe bucket to create a level starting point to bench.

1. Position the bottom of the bucket at a slightly downward angle to aid penetration. Move gear shift to first gear. Lower the bucket into ground and drive forward.
2. Create a windrow of spoil material to build the bench.

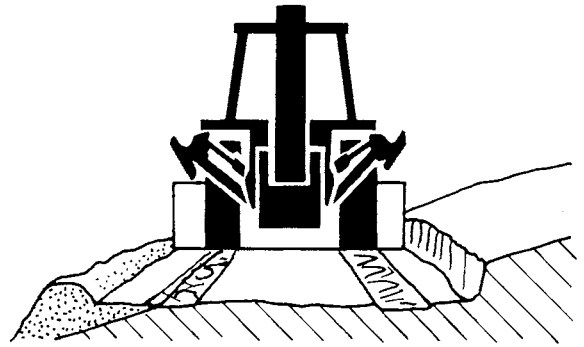

T7208BA -JUN-30JAN90

TX,35,DH1552 -19-29OCT90

3. Push windrow at 45-90° angle to road edge to extend bench. Always keep material in the bucket while moving forward to fill low spots on the bench.

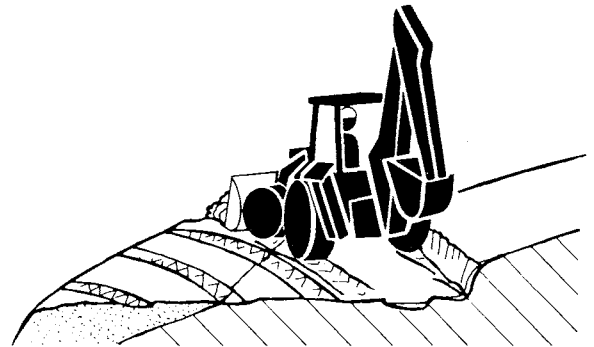

T7208BB -JUN-30JAN90

TX,35,RR,432 -19-22FEB90

**⚠ CAUTION: Prevent possible injury from rollover. DO NOT drop leading front tire past windrow edge. DO NOT work parallel to road edge to compact spoil.**

4. Compact windrow spoil with leading front tire ONLY.

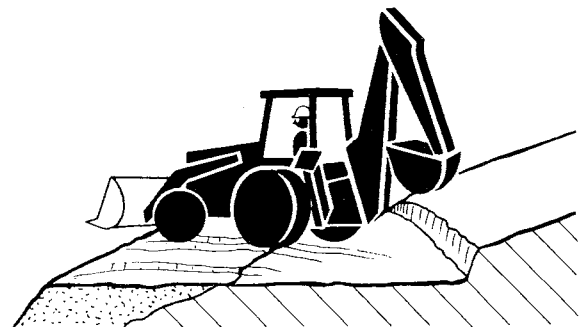

T7208BC -JUN-30JAN90

TX,35,DH1553 -19-29OCT90

**⚠ CAUTION:** Prevent possible injury from falling heavy parts. Approximately weight of 3-point hitch and counterweights is 536 kg (1182 lb).  
10. Install lifting straps on 3-point hitch and attach to a hoist.

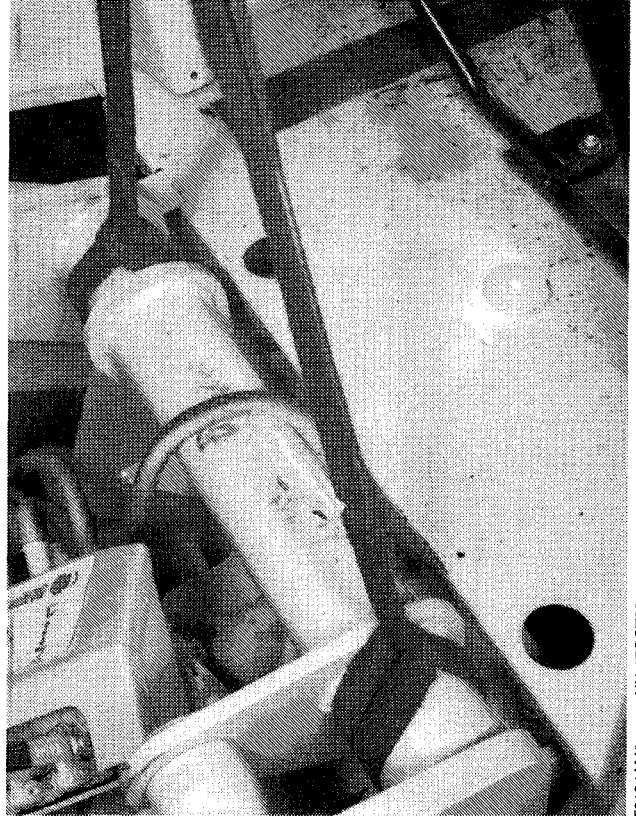

T6184AM2 -UN-17OCT88

11. Remove two bolts with hex nuts (A) and two pins.
12. Carefully remove 3-point hitch attachment from machine.

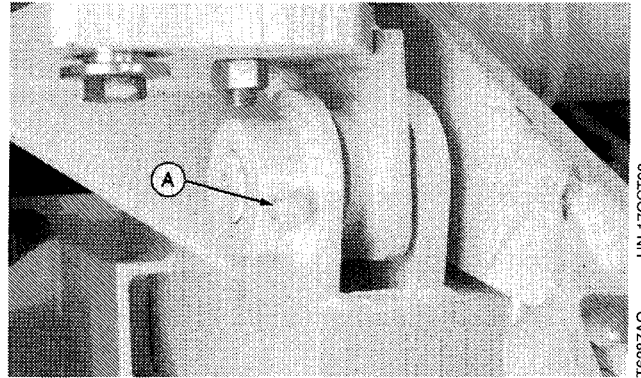

T6287AO -UN-17OCT88

TX,36,RR,2051 -19-03DEC91

**GREASE**

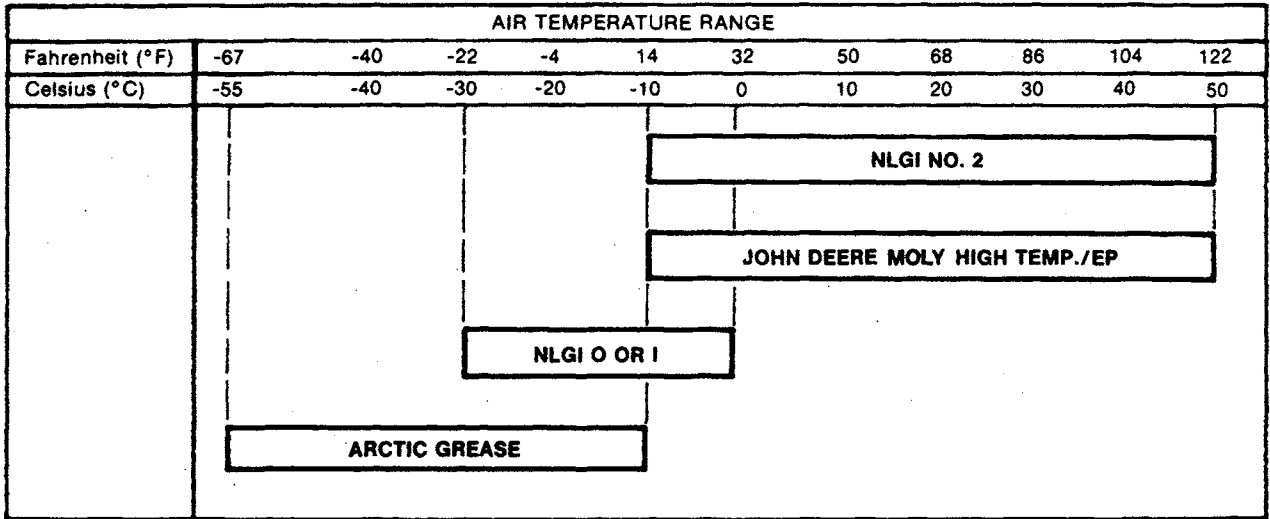

T6722AA -19-27JAN89

Depending on the expected air temperature range, use grease shown on chart above.

Greases recommended are:

- John Deere Moly High Temperature/EP Grease (Preferred)

- SAE Multipurpose Grease with Extreme Pressure (EP) performance and containing 3 to 5 per cent molybdenum disulfide

- SAE multi-purpose EP Grease

- Grease meeting MIL-G-10924C specifications may be used as arctic grease.

02T,45,C49 -19-04DEC91

**GREASE FOR EXTENDIBLE DIPPERSTICK**

SAE Multipurpose Grease with Extreme Pressure (EP) performance and containing 3 to 5 per cent molybdenum disulfide (preferred).

T82,BHFL,D -19-14MAR90

CLICK HERE TO **DOWNLOAD** THE COMPLETE MANUAL

- Thank you very much for reading the preview of the manual.
- You can download the complete manual from: [www.heydownloads.com](http://www.heydownloads.com) by clicking the link below



- Please note: If there is no response to CLICKING the link, please download this PDF first and then click on it.

CLICK HERE TO **DOWNLOAD** THE COMPLETE MANUAL

## OILSCAN® AND COOLSCAN™

OILSCAN and COOLSCAN are John Deere sampling programs to help you monitor machine performance and identify potential problems before they cause serious damage.

Oil and coolant samples should be taken from each system prior to its recommended change interval.

Check with your John Deere dealer for the availability of OILSCAN and COOLSCAN kits.

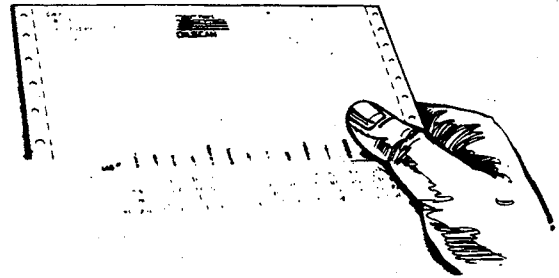
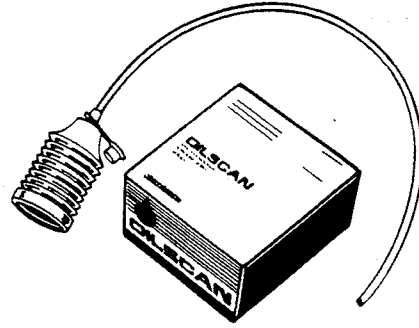

DX,OILSCAN -19-16APR92

T6628AB -JUN-15JUN89

T6629AB -JUN-18OCT88

## CHECK ENGINE OIL LEVEL

The most accurate oil level reading is obtained when the engine is cold before starting the engine for the day's operation.

1. Park machine on a level surface.
2. Set park brake.
3. Make sure dipstick (B) is fully seated.
4. Remove dipstick to check oil level.

**BEFORE THE ENGINE IS STARTED:** The engine is full when oil level is in the cross hatched area (C). It is acceptable to run the engine when the oil level is above the ADD mark.

**AFTER THE ENGINE HAS BEEN RUN:** Allow the oil to drain into the oil pan for 10 minutes before checking the oil level. Ten minutes after shutdown the engine oil level must be above the ADD mark.

5. If necessary, remove filler cap (A) to add oil. (See Fuels and Lubricants chapter.)

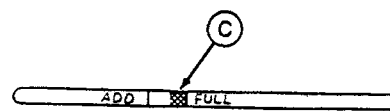
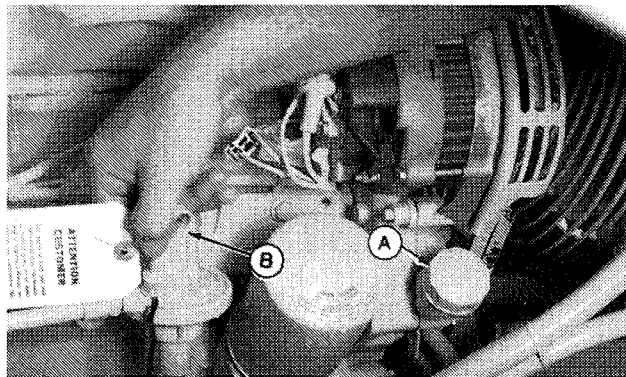

TX,60,RR,2010 -19-03DEC91

T7593AL -JUN-07OCT91

-UN-15DEC88

RG5421

# Maintenance—Every 500 Hours

## CHECK AIR INTAKE HOSE

1. Remove engine side shield.
2. Check hose for cracks.
3. Tighten clamps (A).

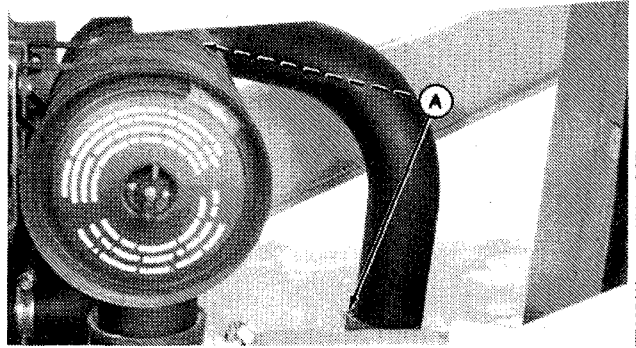

TX,80,RR,2026 -19-03DEC91

T7625AK -JUN-07OCT91

## CHANGE HYDRAULIC OIL FILTER

1. Remove filter by turning it counterclockwise.
2. Apply thin film of oil to gasket of new filter.
3. Install new filter. Turn it clockwise by hand until gasket touches mounting surface.
4. Tighten filter 3/4 to 1 full turn more.
5. Check hydraulic oil level.
6. Start engine. Check for leaks around filter. Tighten filter only enough to stop leaks.
7. Stop the engine. Check hydraulic oil level.

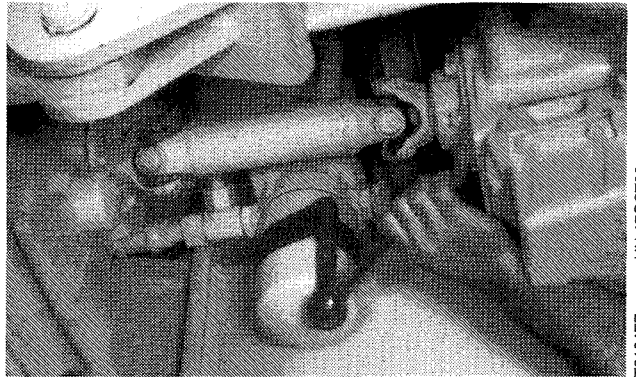

T82,BHPM,KU -19-03DEC91

T6164FZ -JUN-17OCT88

## CHANGE FUEL FILTER

1. Remove retainer spring (A) to remove filter (C). Push on outer tab (B) while pulling up on center tab to disengage inner tab from notch in filter base (D).
2. Clean filter base.
3. Install new filter and retainer spring.

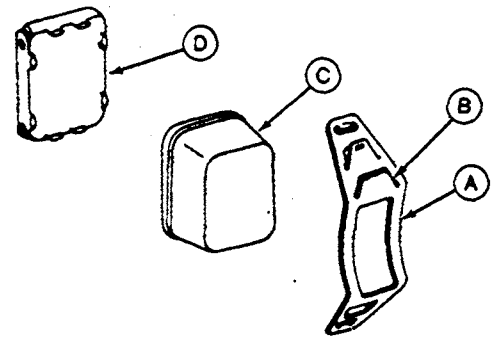

T82,80,C13 -19-11SEP91

T6201A02 -JUN-18OCT88

### CHANGE REVERSER AND TORQUE CONVERTER OIL

1. Remove plug (B) to drain reverser oil.
2. Install JDE-83 Flywheel Turning Tool (C).
3. Remove rubber plug (A) from bottom of housing to gain access to torque converter drain plug.

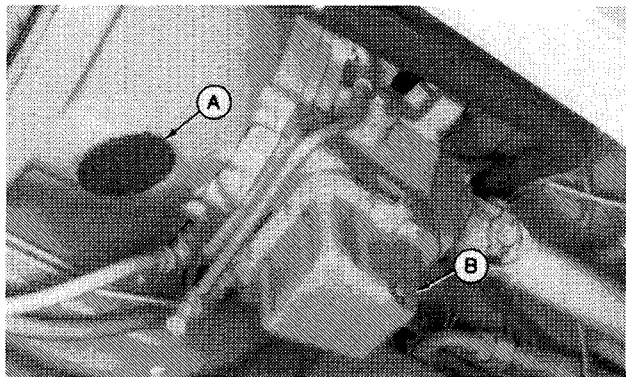

T6164EV -JUN-19OCT88

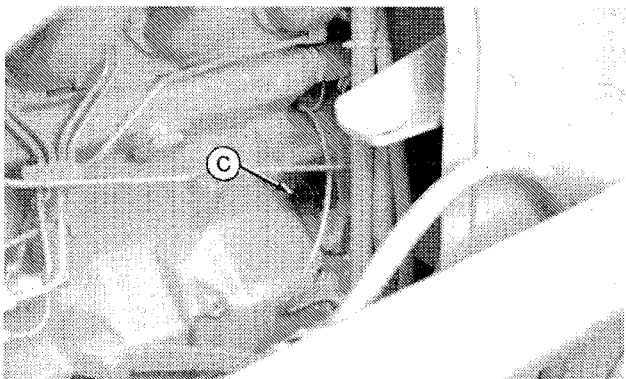

T6669AO -JUN-19OCT88

03T,85,K33 -19-03DEC91

4. Rotate the engine flywheel until the torque converter drain plug (A) is at the bottom.
5. Remove plug and drain oil.
6. Remove engine timing tool.
7. Install reverser and torque converter drain plugs.
8. Install rubber access plug.

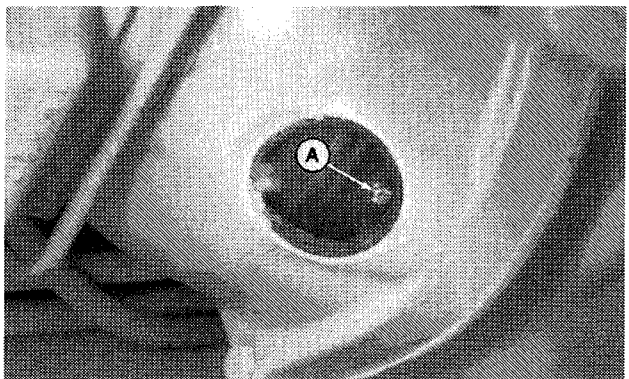

T6001AN -JUN-18OCT88

T82,BHPM,LB -19-09APR86

4. Disconnect fuel line (F) from elbow (E).
5. Remove fuel strainer fitting (D) and strainer (C) from tank.
6. Clean debris from strainer using solvent or diesel fuel. Check strainer for large holes or torn fabric. If necessary, install a new strainer.
7. Flush debris from fuel tank.
8. Clean fitting threads and threads in fuel tank using clean and cure primer.

When replacing strainer, also clean the stud and shoulder on fitting, the end surface and small I.D. opening of strainer.

9. Apply retaining compound to stud on fitting and end surface of strainer.

Push strainer on stud so end of strainer is tight against shoulder of fitting.

10. Apply a bead flexible sealant to threads of fitting.
11. Install fitting and strainer into fuel tank.
12. Tighten hose clamp (B) around fuel tank boss.
13. Connect fuel line.

**IMPORTANT:** When clean and cure primer is used, wait 30 minutes before filling fuel tank to give retaining compound and flexible sealant time to cure. (See manufacturer instruction for more information on cure times of sealant.)

14. Fill fuel tank.
15. Check for leaks.

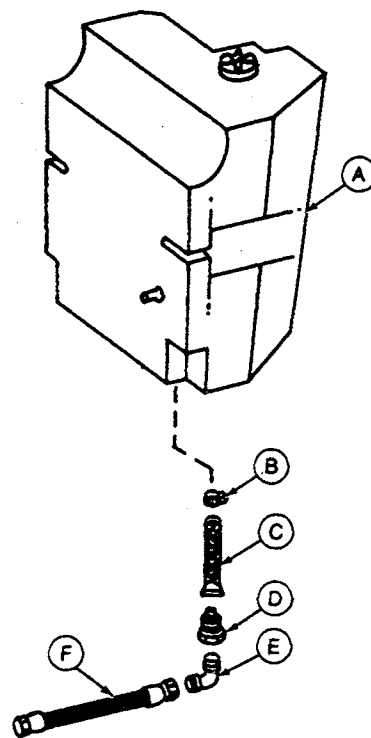

A—Fuel Tank  
 B—Clamp  
 C—Fuel Strainer  
 D—Fitting  
 E—Elbow  
 F—Fuel Line

T6177AY -JUN-17OCT88

## CHECKING PARK BRAKE

1. Engage park brake.
2. Move transaxle gear shift lever to 3rd gear, direction selector lever to forward position, and speed control lever to approximately 1500 rpm engine speed.
3. If tractor moves forward, adjust park brake. (See Adjust Park Brake in this chapter.)

If lever is in last notch of travel when brake is engaged, adjust brake.

TX,90,RR,2002 -19-03DEC91

## ADJUSTING THE PARK BRAKE



T7975AN  
-JUN-08APR93











1. Park machine on level surface and lower all equipment to ground.
2. Move transaxle gear shift lever to neutral and lock direction selector lever in neutral.
3. Stop the engine. Block wheels to prevent movement.

*NOTE: Park brake must not be engaged while adjusting.*

4. Position park brake lever with latch in bottom notch.

TX,90,DS4747 -19-20MAY93

**UNIFIED INCH BOLT AND CAP SCREW TORQUE VALUES**

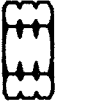
SAE Grade and Head Markings	1 or 2 <sup>b</sup>	5	5.1	5.2	8	8.2
	NO MARK 					
SAE Grade and Nut Markings	2	5		8		
	NO MARK 					

Size	Grade 1				Grade 2 <sup>b</sup>				Grade 5, 5.1, or 5.2				Grade 8 or 8.2			
	Lubricated <sup>a</sup>		Dry <sup>a</sup>		Lubricated <sup>a</sup>		Dry <sup>a</sup>		Lubricated <sup>a</sup>		Dry <sup>a</sup>		Lubricated <sup>a</sup>		Dry <sup>a</sup>	
	N·m	lb-ft	N·m	lb-ft	N·m	lb-ft	N·m	lb-ft	N·m	lb-ft	N·m	lb-ft	N·m	lb-ft	N·m	lb-ft
1/4	3.7	2.8	4.7	3.5	6	4.5	7.5	5.5	9.5	7	12	9	13.5	10	17	12.5
5/16	7.7	5.5	10	7	12	9	15	11	20	15	25	18	28	21	35	26
3/8	14	10	17	13	22	16	27	20	35	26	44	33	50	36	63	46
7/16	22	16	28	20	35	26	44	32	55	41	70	52	80	58	100	75
1/2	33	25	42	31	53	39	67	50	85	63	110	80	120	90	150	115
9/16	48	36	60	45	75	56	95	70	125	90	155	115	175	130	225	160
5/8	67	50	85	62	105	78	135	100	170	125	215	160	215	160	300	225
3/4	120	87	150	110	190	140	240	175	300	225	375	280	425	310	550	400
7/8	190	140	240	175	190	140	240	175	490	360	625	450	700	500	875	650
1	290	210	360	270	290	210	360	270	725	540	925	675	1050	750	1300	975
1-1/8	470	300	510	375	470	300	510	375	900	675	1150	850	1450	1075	1850	1350
1-1/4	570	425	725	530	570	425	725	530	1300	950	1650	1200	2050	1500	2600	1950
1-3/8	750	550	950	700	750	550	950	700	1700	1250	2150	1550	2700	2000	3400	2550
1-1/2	1000	725	1250	925	990	725	1250	930	2250	1650	2850	2100	3600	2650	4550	3350

DO NOT use these values if a different torque value or tightening procedure is given for a specific application. Torque values listed are for general use only. Check tightness of fasteners periodically.

Shear bolts are designed to fail under predetermined loads. Always replace shear bolts with identical grade.

<sup>a</sup> "Lubricated" means coated with a lubricant such as engine oil, or fasteners with phosphate and oil coatings. "Dry" means plain or zinc plated without any lubrication.

<sup>b</sup> Grade 2 applies for hex cap screws (not hex bolts) up to 152 mm (6-in.) long. Grade 1 applies for hex cap screws over 152 mm (6-in.) long, and for all other types of bolts and screws of any length.

Fasteners should be replaced with the same or higher grade. If higher grade fasteners are used, these should only be tightened to the strength of the original.

Make sure fasteners threads are clean and that you properly start thread engagement. This will prevent them from failing when tightening.

Tighten plastic insert or crimped steel-type lock nuts to approximately 50 percent of the dry torque shown in the chart, applied to the nut, not to the bolt head. Tighten toothed or serrated-type lock nuts to the full torque value.

Operational Checkout

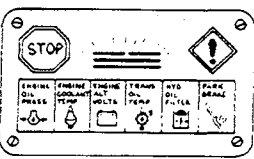
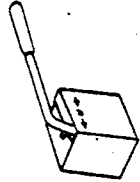
<p><b>START CIRCUIT CHECK</b></p>	 <p>T6171AA -UN-09DEC88</p> <p>Move directional lever fore and aft in neutral position and turn key to START position.</p> <p>Observe and listen to monitor as engine is cranking.</p> <p><i>LISTEN: Starting motor must operate.</i></p> <p><i>LISTEN: Alarm must "BEEP".</i></p> <p><i>LOOK: During engine cranking, all six indicator lights must be on, "SERVICE REQUIRED" must light, and "STOP" must flash.</i></p>	<p><b>OK:</b> Go to next check.</p> <p><b>NOT OK:</b> Go to Troubleshooting - Electrical System (See Starting Motor Will Not Turn.)</p> <p>TX,95,DS4750 -19-20MAY93</p>
<p><b>REVERSE WARNING ALARM CHECK (IF EQUIPPED)</b></p>	 <p>T6257AE -UN-25MAY89</p> <p>Put transaxle in neutral.</p> <p>Release park brake.</p> <p>Start engine.</p> <p>Move directional lever to reverse position.</p> <p><i>LISTEN: Reverse warning alarm must sound.</i></p>	<p><b>OK:</b> Go to next check.</p> <p><b>NOT OK:</b> Check wiring. Go to Maintenance - Electrical System (Reverse Warning Alarm or see an authorized dealer.)</p> <p>TX,95,DS5754 -19-20MAY93</p>
<p><b>STARTING AID CHECK (IF EQUIPPED)</b></p>	<p>Run engine at slow idle.</p> <p>Push start aid button once.</p> <p><i>LISTEN: Engine speed must increase then return to slow idle.</i></p>	<p><b>OK:</b> Go to next check.</p> <p><b>NOT OK:</b> Check contents of can by shaking.</p> <p><b>IF OK:</b> Check fuse. Go to Troubleshooting - Gauges and Indicators (See Start Aid Does Not Operate.)</p> <p>TX,95,DS4755 -19-20MAY93</p>

**8 HYDRAULIC SYSTEM CHECKS**

05T,95,K107 -19-26SEP91

**MAIN HYDRAULIC PUMP PERFORMANCE CHECK**

*NOTE: If hydraulic oil is not at operating temperature, heat hydraulic oil until loader and backhoe cylinders feel warm to touch.*

- a. Put loader bucket flat on ground.
  - b. Run engine at slow idle.
  - c. Measure cycle time of loader raise to maximum height (including bucket leveling).
- LOOK: The maximum cycle time is 15 seconds.*
- NOTE: Take the average cycle time for at least 3 complete cycles. This time will give a general indication of hydraulic pump performance.*

**OK:** Go to next check.

**NOT OK:** If cycle time is slow, go to Troubleshooting chapter, Hydraulic, Slow Hydraulic Functions.

TX,95,FF706 -19-08SEP89

**STEERING HYDRAULIC PUMP PERFORMANCE CHECK**

*NOTE: Hydraulic oil should be at operating temperature.*

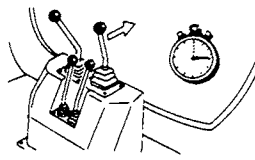

T6171AP -UN-09DEC88

- Put backhoe in transport position.
- Run engine at fast idle.
- While holding loader valve boom raise over relief, extend dipperstick full cycle and measure cycle time.

*LOOK: The maximum cycle time is 15 seconds.*

**OK:** Go to next check.

**NOT OK:** If cycle time is slow, go to Troubleshooting chapter, Hydraulic, Slow Hydraulic Functions.

05T,95,RR,2005 -19-03DEC91

## Troubleshooting

Symptom	Problem	Solution
	Debris in fuel or wrong fuel grade.	Check fuel tank strainer (with flashlight) and examine fuel. Check fuel filter for debris. Clean. Check grade of fuel.
	Idle speeds out of adjustment (too low).	See your authorized dealer.
	Fuel injection pump out of time.	See your authorized dealer.
	Fuel transfer pump.	See your authorized dealer.
	Injection pump governor worn or metering valve sticking.	See your authorized dealer.
	Engine overheating.	See your authorized dealer.
	Incorrect valve clearance.	Check and adjust valve clearance.
	Bent push rods.	See your authorized dealer.
	Cylinder head gasket leaking.	See your authorized dealer.
	Valve sticking or burned.	See your authorized dealer.
	Worn or broken compression rings.	See your authorized dealer.
	Fuel injection pump.	See your authorized dealer.
	Injection nozzles(s).	See your authorized dealer.
<b>Engine Does Not Develop Full Power</b>	Fuel tank strainer plugged.	Check water trap for debris with a flashlight through filler neck toward bottom right corner of fuel tank.
	Fuel filter clogged.	Replace fuel filter.
	Fuel tank strainer plugged.	Check water trap for debris with a flashlight through filler neck toward bottom right corner of fuel tank.
	Fuel filter clogged.	Replace fuel filter.
	Wrong grade of fuel.	Drain and add correct fuel.
	Air system restricted.	Check air filter restriction indicator and air filters.

Continued on next page

## Troubleshooting

Symptom	Problem	Solution
	Using low viscosity oil in hot weather.	Use recommended oil.
	Plugged oil cooler.	Clean oil cooler.
	Incorrect system relief valve pressure.	See your authorized dealer.
<b>Foaming Oil</b>	Oil level too low or too high.	Check oil level. Adjust to full mark on dipstick.
	Incorrect type of oil.	Use recommended oil.
	Pump suction screen restricted (aeration of inlet oil).	Inspect and clean screen in hydraulic reservoir. (See Maintenance chapter.)
	Air leak on suction side of pump.	See your authorized dealer.
<b>Hydraulic Pump Leaking</b>	Cap screws that hold pump sections are loose.	Tighten to torque specifications. See your authorized dealer.
	Worn shaft seal.	See your authorized dealer.
	Broken diaphragm "vee" seal or backup gasket.	See your authorized dealer.
<b>Excessive Pump Noise</b>	Low oil level.	Add oil to correct level.
	Hydraulic filter restricted.	Replace filter.
	Pump suction screen restricted (aeration of inlet oil).	Inspect and clean screen in hydraulic reservoir. (See Maintenance chapter.) Check and tighten suction hose clamps.
	Oil lines in contact with operator's station (failed rubber isolators).	Inspect and repair.
	Loose pump drive coupling.	Inspect and tighten coupling. See your authorized dealer.
	Pump attaching hardware loose.	Retighten to specification torque.
	Leakage in hydraulic circuit.	See your authorized dealer.
<b>Sliding Frame Lock Does Not Release</b>	Fuse failure.	Check and replace, if necessary.
	Switch.	Inspect for power to switch.

Continued on next page

**MECHANICAL FRONT WHEEL DRIVE (MFWD) SYSTEM**

Symptom	Problem	Solution
<b>No Power To Either MFWD Wheel</b>	MFWD valve linkage disconnected	Connect MFWD valve linkage.
	Failed drive shaft universal joints or drive output shaft	Inspect and repair. See your authorized dealer.
	Failed gear in MFWD transfer case	Raise all wheels off ground with engine running. Engage front wheel drive. If MFWD shaft does not turn, see your authorized dealer.
	Failed ring or pinion in MFWD	Raise all wheels off ground with engine running. Engage front wheel drive. If MFWD drive shaft turns and wheel constant velocity joints do not turn, see your authorized dealer.
<b>No Power To One MFWD Wheel</b>	Wheel constant velocity joint failure	Inspect and repair. See your authorized dealer.
	Failed axle shaft in MFWD	Raise all wheels off ground with engine running. Engage front wheel drive. If power does not turn. See your authorized dealer.
	Failed outboard planetary	Raise all wheels off ground with engine running. Engage front wheel drive. MFWD constant velocity joint will turn but the front tire will not. See your authorized dealer.
	Failed limited-slip in MFWD	Raise rear tires off ground. Turn steering wheel for a full left or right turn. Set engine at 1200 rpm and engage MFWD. Both front wheels must turn and pull front of unit in direction of tire rotation. If only one tire will pull unit or scuff the ground, see your authorized dealer.
<b>No Power To One Wheel (Under Load)</b>	Failed limited-slip in MFWD	Raise rear tires off ground. Turn steering wheel for a full left or right turn. Set engine at approximately 1200 rpm and engage MFWD. If only one wheel spins, see your authorized dealer.
<b>MFWD Whines or Makes Excessive Noise</b>	Low oil level	Check MFWD oil level. Add oil as necessary.
	Worn U-joints in drive shaft	Inspect and repair.
	Incorrect MFWD differential backlash	See your authorized dealer.

*Specifications*

Index

	Page		Page
Control valve . . . . .	90-23	Engine	
Controls, heater . . . . .	10-21	Boost starting . . . . .	20-6
Converter oil temperature indicator . . . . .	10-4	Break-in . . . . .	15-1
Coolant		Breather tube . . . . .	85-10
Drain . . . . .	90-1	Coolant conditioner, add . . . . .	80-3
Heater . . . . .	20-7	Coolant level . . . . .	60-2
Temperature indicator . . . . .	10-3	Coolant temperature indicator . . . . .	10-3
Coolant conditioner, engine . . . . .	80-3	Oil change . . . . .	75-1
Coolant level, engine . . . . .	60-2	Oil filter . . . . .	75-1
Coolant, engine . . . . .	90-2	Oil level . . . . .	60-3
Coolant, test . . . . .	90-3	Oil pressure indicator . . . . .	10-3
Cooling system . . . . .	60-2, 90-2	Oil specification . . . . .	40-5
Crankcase ventilation tube, engine,		Side shield removing . . . . .	50-3
change . . . . .	85-10	Specifications . . . . .	115-2
Cycle times, backhoe . . . . .	90-15	Speed control . . . . .	20-3
Cylinder		Speed control lever . . . . .	30-3
Service . . . . .	90-23	Speed control linkage adjust . . . . .	85-4
Cylinder rod end, backhoe bucket,		Speed, adjust . . . . .	85-3
lubricate . . . . .	60-7	Starting . . . . .	20-2
Cylinder, steering, lubricate . . . . .	60-5	Stopping . . . . .	20-9
		Troubleshooting . . . . .	100-2
		Valve lash (clearance), adjust . . . . .	85-1
		Engine coolant . . . . .	90-2
<b>D</b>		Engine coolant, test . . . . .	90-3
Differential lock		Extendable dipperstick	
Pedal . . . . .	10-5	Pedal . . . . .	35-8
Differential lock operation . . . . .	35-11	Extendible dipperstick	
Digging		Control pedal . . . . .	10-5
Backhoe bucket . . . . .	35-25	Extendible dipperstick lubrication	
Loader bucket . . . . .	35-27	Bearing strips . . . . .	60-5
Dipperstick pedal, three lever . . . . .	35-5	Extendible dipperstick, grease	
Dipperstick, extendible, lubrication . . . . .	60-5	specification . . . . .	40-8
Dipperstick, extendible, oil specification . . . . .	40-8		
Direction selector lever . . . . .	30-4	<b>F</b>	
Direction selector lever		Feet, reversible stabilizer . . . . .	35-19
Linkage, adjust . . . . .	90-19	Filter	
Door		Engine oil . . . . .	75-1
Cylinder adjustment . . . . .	10-19	Fuel . . . . .	80-1, 90-4
Opener . . . . .	10-19	Hydraulic oil . . . . .	80-1
Drain engine coolant . . . . .	90-1	Primary air . . . . .	55-1
Driving on a slope . . . . .	35-22	Four lever backhoe controls . . . . .	10-7
Driving the machine . . . . .	30-1	Four lever pattern	
		Backhoe . . . . .	35-7
<b>E</b>		Front axle housing—(MFWD) oil change . . . . .	85-11
Electrical		Front wheel drive control handle . . . . .	10-7
Troubleshooting . . . . .	100-8	Fuel	
Electrolyte specifications . . . . .	90-9	Bleeding system . . . . .	80-2
Elements, air cleaner . . . . .	55-1	Filter drain sediment . . . . .	90-4

CLICK HERE TO **DOWNLOAD** THE COMPLETE MANUAL

- Thank you very much for reading the preview of the manual.
- You can download the complete manual from: [www.heydownloads.com](http://www.heydownloads.com) by clicking the link below



- Please note: If there is no response to CLICKING the link, please download this PDF first and then click on it.

CLICK HERE TO **DOWNLOAD** THE COMPLETE MANUAL