

200D and 200DLC Excavator

OPERATOR'S MANUAL 200D and 200DLC Excavator OMT226908 ISSUE F0 (ENGLISH)

CALIFORNIA

Proposition 65 Warning

Diesel engine exhaust and some of its constituents are known to the State of California to cause cancer, birth defects, and other reproductive harm.

If this product contains a gasoline engine:

WARNING

The engine exhaust from this product contains chemicals known to the State of California to cause cancer, birth defects or other reproductive harm.

The State of California requires the above two warnings.

Additional Proposition 65 Warnings can be found in this manual.

**Worldwide Construction
And Forestry Division**
LITHO IN U.S.A.

CLICK HERE TO **DOWNLOAD** THE COMPLETE MANUAL

- Thank you very much for reading the preview of the manual.
- You can download the complete manual from: www.heydownloads.com by clicking the link below



- Please note: If there is no response to CLICKING the link, please download this PDF first and then click on it.

CLICK HERE TO **DOWNLOAD** THE COMPLETE MANUAL

Wear Protective Equipment

Guard against injury from flying pieces of metal or debris; wear goggles or safety glasses.

Wear close fitting clothing and safety equipment appropriate to the job.

Prolonged exposure to loud noise can cause impairment or loss of hearing. Wear suitable hearing protection such as earmuffs or earplugs to protect against objectionable or uncomfortable loud noises.

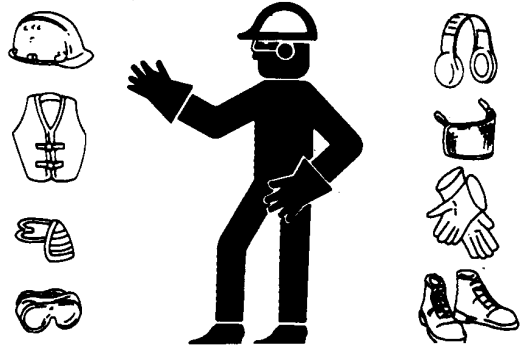

TS206—UN—23AUG88

TX03679,00016D0 -19-03JAN07-1/1

Avoid Unauthorized Machine Modifications

John Deere recommends using only genuine John Deere replacement parts to ensure machine performance. Never substitute genuine John Deere parts with alternate parts not intended for the application as these can create hazardous situations or hazardous performance. Non-John Deere parts, or any damage or failures resulting from their use are not covered by any John Deere warranty.

Modifications of this machine, or addition of unapproved products or attachments, may affect machine stability or

reliability, and may create a hazard for the operator or others near the machine. The installer of any modification which may affect the electronic controls of this machine is responsible for establishing that the modification does not adversely affect the machine or its performance.

Always contact an authorized dealer before making machine modifications that change the intended use, weight or balance of the machine, or that alter machine controls, performance or reliability.

AM40430,00000A9 -19-20AUG09-1/1

Add Cab Guarding for Special Uses

Special work situations or machine attachments may create an environment with falling or flying objects. Working near an overhead bank, doing demolition work, using a hydraulic hammer, or working in a wooded area, for example, may require added guarding to protect the operator.

FOPS (falling object protective structures) and special screens or guarding should be installed when falling or flying objects may enter or damage the machine. Contact your authorized dealer for information on devices intended to provide protection in special work situations.

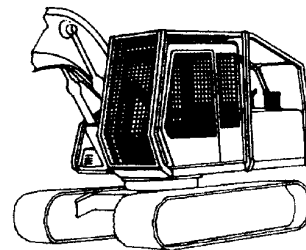

T133733—UN—15SEP00

TX03679,00016CE -19-03JAN07-1/1

Safety—Maintenance Precautions

Park and Prepare for Service Safely

Warn others of service work. Always park and prepare your machine for service or repair properly.

- Park machine on a level surface and lower equipment and attachments to the ground.
- Place pilot shutoff lever in “lock” position. Stop engine and remove key.
- Attach a “Do Not Operate” tag in an obvious place in the operator’s station.

Securely support machine or attachment before working under it.

- Do not support machine with boom, arm, or other hydraulically actuated attachments.
- Do not support machine with cinder blocks or wooden pieces that may crumble or crush.
- Do not support machine with a single jack or other devices that may slip out of place.

Understand service procedures before beginning repairs. Keep service area clean and dry. Use two people whenever the engine must be running for service work.

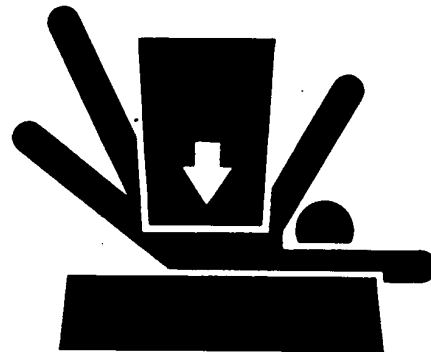

T133332—19—14DEC01

TS229—UN—23AUG88

TX03679,00016E9 -19-03JAN07-1/1

Service Cooling System Safely

Explosive release of fluids from pressurized cooling system can cause serious burns.

Do not service radiator through the radiator cap. Only fill through the surge tank filler cap. Shut off engine. Only remove surge tank filler cap when cool enough to touch with bare hands. Slowly loosen cap to relieve pressure before removing completely.



TS281—UN—23AUG88

DW90712,000043B -19-10JAN07-1/1

Horn

Horn switch (1) is located on top of left control lever.

1—Horn Switch

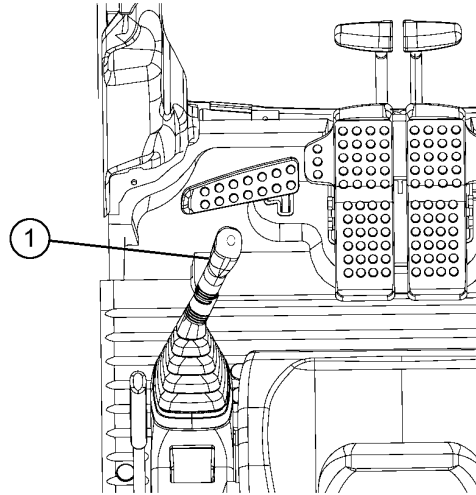

T140123 —UN—20MAR01

TX14740,0001CEA -19-03JAN07-1/1

Power Dig Button

Press and hold down power dig button (1) on bottom center of right pilot control lever for an 8 second increase in hydraulic power. Release button to reset power dig function.

Power dig is automatically activated when the following conditions are met:

- Boom Up
- No Arm In
- High Delivery Pressure

1—Power Dig Button

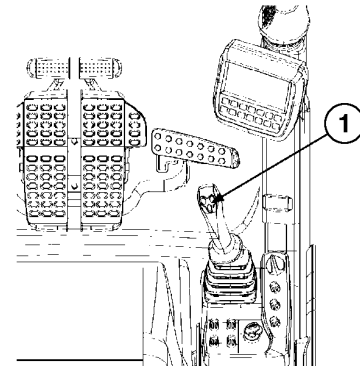

Three Button Pilot Control Lever Shown

T214908 —UN—29NOV05

DW90712,00002FA -19-13MAR07-1/1

Pilot Shutoff Lever

The pilot shutoff lever (1) shuts off hydraulic pilot pressure to all pilot control valves. When pilot shutoff lever is in locked (UP) position, the machine will not move if a lever or pedal is accidentally moved. Engine will not start with pilot shutoff lever in the unlocked (DOWN) position.

Always pull pilot shutoff lever to locked position when you stop the engine or leave the operator's station.

Push pilot shutoff lever forward to unlocked position to operate machine.

1—Pilot Shutoff Lever

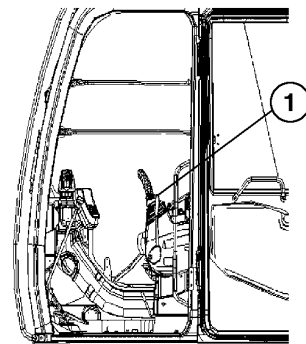

Lever In Locked Position

T214909 —UN—29NOV05

DW90712,00002FB -19-03JAN07-1/1

Operation—Monitor Operation

Monitor

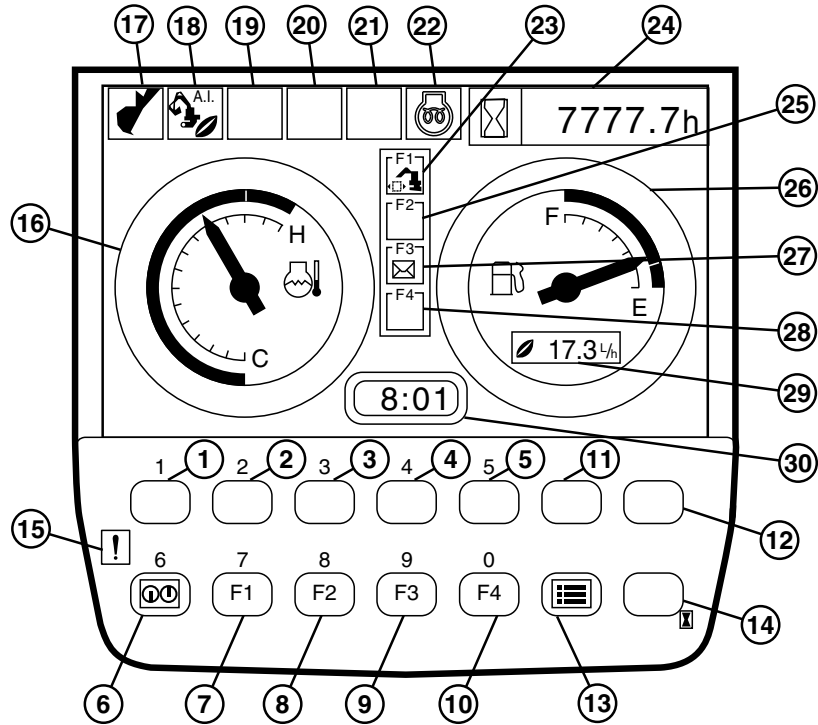

TX1001230

- | | | | |
|---|-----------------------------------|----------------------------------|----------------------------------|
| 1— Button 1 | 9— Button 9 / F3 Function Button | 17— Work Mode Indicator | 25— F2 Function Button Indicator |
| 2— Button 2 | 10— Button 0 / F4 Function Button | 18— Auto-Idle Indicator | 26— Fuel Gauge |
| 3— Button 3 | 11— Select Button | 19— Auxiliary Indicator | 27— F3 Function Button Indicator |
| 4— Button 4 | 12— Back Button | 20— Auxiliary Indicator | 28— F4 Function Button Indicator |
| 5— Button 5 | 13— Menu Button | 21— Auxiliary Indicator | 29— Fuel Rate Display |
| 6— Button 6 / Return to Default Screen Button | 14— Hour Meter Button | 22— Engine Preheat Indicator | 30— Clock |
| 7— Button 7 / F1 Function Button | 15— Alarm Indicator Light | 23— F1 Function Button Indicator | |
| 8— Button 8 / F2 Function Button | 16— Coolant Temperature Gauge | 24— Hour Meter | |

TX1001230—UN—04JAN06

DW90712,000046B -19-29JAN07-1/1

- Push the select button to display the interval ON/OFF settings screen.

Maintenance Information Display ON/OFF

- Select ON or OFF for maintenance information display by using buttons (1) or (2). Push the select button.
 - ON: When it is time to perform maintenance on the selected item, an information message is displayed on the screen.
 - OFF: No information message is displayed.
- In order to apply setting, push the back button (12) to return to the default screen.

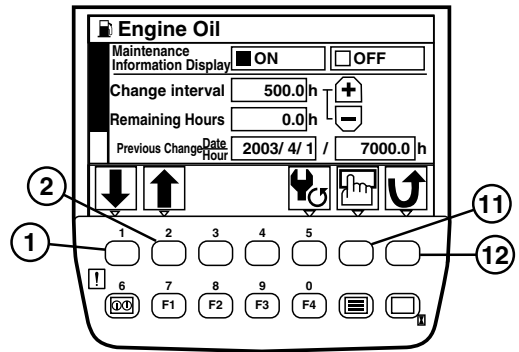

Interval ON/OFF Screen

Change Interval Settings

IMPORTANT: Change interval can only be set when maintenance information display is set to ON.

- Navigate to the item Change interval by using buttons (1) or (2).
- Set hour for change interval by using buttons (3) or (4).
- Navigate to Remaining Hours by using buttons (1) or (2) and push the select button (11).

NOTE: To return to the previous screen without adjusting remaining hours to change interval, push the back button (12).

- The message “Adjust remaining hours to new change interval. OK?” displays. Push the select button to confirm change.

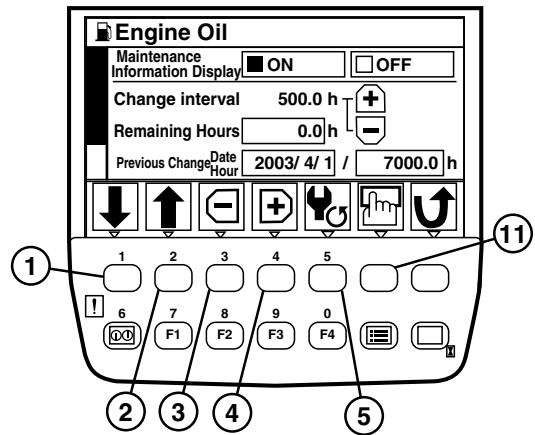

Interval ON/OFF Screen

Resetting Data

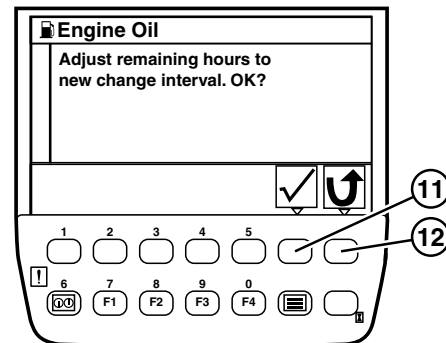

Continued on next page

DW90712.0000475 -19-29JAN07-4/5

TX1001284 —19—27JAN06

TX1001282 —19—27JAN06

TX1001283 —19—15DEC05

Engine Break-In Period

NOTE: To avoid engine damage it is critical to observe the engine break-in period. Extra care during the first 250 hours of operation will result in more satisfactory long-term engine performance and life. **DO NOT** exceed 250 hours of operation with break-in oil.

1. Operate the machine at heavy or normal loads with minimal idling during the break-in period. During the first 20 hours, avoid prolonged periods of engine idling or sustained maximum load operation. If engine will idle longer than 5 minutes, stop engine.
2. Check engine oil level more frequently during the engine break-in period.

IMPORTANT: DO NOT add make-up oil until the oil level is **BELOW** the **ADD** mark on the dipstick. **John Deere ENGINE BREAK-IN OIL**

should be used to make up any oil consumed during the break-in period.

3. Change oil and oil filter after first 250 hours (maximum). Fill crankcase with the normal seasonal viscosity grade oil. See Maintenance—Machine. (Section 3-1.)
4. Watch coolant temperature gauge closely. If coolant temperature rises above specified limits on the gauge, reduce load on engine. Unless temperature drops quickly, stop the engine and determine the cause before resuming operation. See Troubleshooting. (Section 4-3.)
5. Watch oil pressure gauge for pressure within specification.
6. Check serpentine belt for proper alignment and seating in pulley grooves.

VD76477.00016F2 -19-06JUL09-1/1

Starting Engine

Before Starting the Engine

Turn key switch to ON position. Wait for “System Starting” screen to disappear before starting machine.

NOTE: The pilot shutoff lever must be in the locked (UP) position to start machine.

Starting the Engine

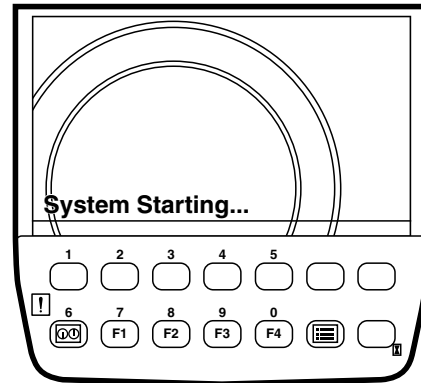

System Starting Screen

Continued on next page

DW90712.00002C2 -19-13MAR07-1/2

TX1000374 —JUN—29NOV05

Operating In Water and Mud

Be careful not to operate the machine in water or mud above the upper deck surface of the undercarriage, causing the swing bearing and rotary manifold to be submerged.

If the swing bearing and rotary manifold are submerged, remove cover from underneath center of machine. Remove drain plug (1) to drain water and mud.

Clean swing gear area. Install plug and cover. Grease swing gear and swing bearing.

1— Drain Plug

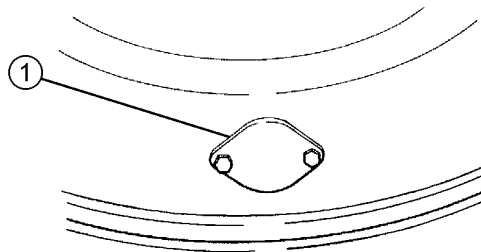

T136459 —UN—18DEC00

TX14740,0001CAF -19-03JAN07-1/1

Driving Up a Steep or Slippery Slope

CAUTION: Prevent possible injury from machine rollover. Use this technique only on a short slope. Machine depends on support of boom/arm/bucket during entire procedure until machine reaches top of slope. Repositioning the bucket during this procedure is NOT recommended. DO NOT swing upperstructure during this procedure. DO NOT reposition bucket during this procedure.

1. Wear seat belt.

2. Position undercarriage so travel motors will be on uphill end of machine.
3. Push bucket into the ground.
4. When boom is on uphill end of machine: Pull machine using boom and arm cylinder to help travel motors.

When boom is on downhill end of machine: Push machine using boom and arm cylinder to help travel motors.

DW90712,00002C6 -19-03JAN07-1/1

Lifting

CAUTION: Lifting requires special care. Observe these rules when lifting with the machine:

- Never use machine to lift people
- Do not exceed lift capacity limits
- Keep everyone clear of raised loads
- Never attach sling or chain to bucket teeth
- Use tether lines to guide loads
- Use hand signals to communicate with others

1. Use proper rigging to attach and stabilize loads.
2. Without bucket loop: Curl bucket and retract arm. Fasten sling or chain to bucket pivot pin.

With bucket loop: Curl bucket and retract arm. Fasten sling or chain to bucket loop.

3. Check stability by carefully doing a trial lift:
 - Raise load just off of ground
 - Swing load all the way to one side
 - Move load slowly away from machine
 - Lower load immediately if machine is not stable

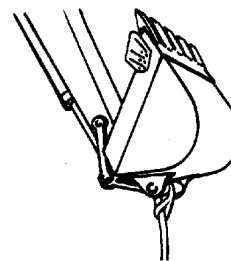

Without Bucket Loop

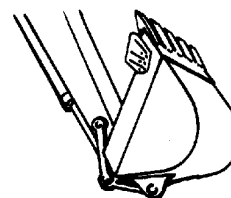

With Bucket Loop

T133649 —UN—02NOV00

T135070 —UN—02NOV00

DW90712,00005E4 -19-13MAR07-1/1

Alternative and Synthetic Lubricants

Conditions in certain geographical areas may require lubricant recommendations different from those printed in this manual. Some John Deere brand coolants and lubricants may not be available in your location.

Synthetic lubricants may be used if they meet the performance requirements as shown in this manual.

The temperature limits and service intervals shown in this manual apply to both conventional and synthetic oils.

Re-refined base stock products may be used if the finished lubricant meets the performance requirements.

If alternative hydraulic oils are required, the hydraulic system needs to be completely flushed. This may require large amounts of oil to properly drain previous product.

NOTE: The following alternative oils could be used if factory fill has been completely flushed out. If using the following alternative oils, a reduced service interval of 1500 hours must be maintained.

Texaco Rando 46

Mobil DTE25-46

Shell Tellus T46

IMPORTANT: Avoid mixing different brands or types of oils. Oil manufacturers blend base stock and additives to create their oils and to meet certain specifications and performance requirements. Mixing different oils can interfere with proper functioning of these formulations and degrade lubricant performance.

This machine is factory filled with Super EX 46HN extended life zinc-free hydraulic oil. Avoid servicing this machine with products that do not meet this specification. If oils have been mixed or if alternate service oils are desired, the complete hydraulic system needs to be totally flushed by an authorized dealer.

Consult your authorized dealer to obtain specific information and recommendations.

DW90712,000057F -19-15DEC09-1/1

Supplemental Coolant Additives

Some coolant additives will gradually deplete during engine operation. For John Deere COOL-GARD™ Premix, COOL-GARD Concentrate, or John Deere COOL-GARD PG Premix, replenish coolant additives between drain intervals by adding a supplemental coolant additive as determined necessary by coolant testing.

John Deere LIQUID COOLANT CONDITIONER is recommended as a supplemental coolant additive for John Deere COOL-GARD Premix, COOL-GARD Concentrate, and COOL-GARD PG Premix.

John Deere LIQUID COOLANT CONDITIONER is not designed for use with COOL-GARD II Premix or COOL-GARD II Concentrate.

IMPORTANT: Do not add a supplemental coolant additive when the cooling system is drained and refilled with any of the following:

COOL-GARD is a trademark of Deere & Company

- John Deere COOL-GARD II
- John Deere COOL-GARD
- John Deere COOL-GARD PG

If other coolants are used, consult the coolant supplier and follow the manufacturer's recommendation for use of supplemental coolant additives.

The use of non-recommended supplemental coolant additives may result in additive drop-out and gelation of the coolant.

Add the manufacturer's recommended concentration of supplemental coolant additive. DO NOT add more than the recommended amount.

DX,COOL4 -19-03NOV08-1/1

Operating in Warm Temperature Climates

John Deere engines are designed to operate using glycol base engine coolants.

Always use a recommended glycol base engine coolant, even when operating in geographical areas where freeze protection is not required.

John Deere COOL-GARD™ II Premix is available in a concentration of 50% ethylene glycol. However, there are situations in warm temperature climates where a coolant with lower glycol concentration (approximately 20% ethylene glycol) has been approved. In these cases, the low glycol formulation has been modified to provide the same level of corrosion inhibitor as John Deere COOL-GARD II Premix (50/50).

COOL-GARD is a trademark of Deere & Company

IMPORTANT: Water may be used as coolant *in emergency situations only.*

Foaming, hot surface aluminum and iron corrosion, scaling, and cavitation will occur when water is used as the coolant, even when coolant conditioners are added.

Drain cooling system and refill with recommended glycol base engine coolant as soon as possible.

DX,COOL6 -19-03NOV08-1/1

Maintenance—As Required

Remove and Clean Fuel Tank Inlet Screen

Clean screen (1) to remove any debris. Use solvent or diesel fuel.

Replace screen if damaged.

1— Fuel Tank Inlet Screen

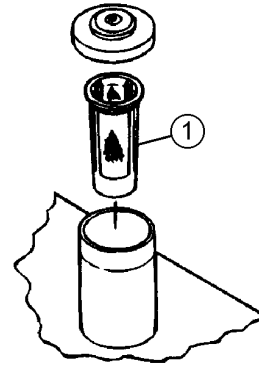

T135186 —UN—06NOV00

ER79617,0000A84 -19-06APR10-1/1

Check Windshield Washer Fluid

Check fluid in windshield washer tank (1). If necessary, remove fill cap to add fluid.

During winter season, use all season windshield washer fluid which will not freeze.

1— Windshield Washer Tank



T214862A —UN—04OCT05

ER79617,0000A85 -19-19MAR10-1/1

Drain Water and Sediment from Fuel Tank Sump

1. Park machine on a level surface. Rotate upperstructure 90° for easier access.
2. Stop engine.
3. Remove fuel tank fill cap.
4. Open drain valve (1) for several seconds to drain water and sediment into a container. Dispose of waste properly. Close drain valve.
5. Install fill cap.

1— Drain Valve



T6811AJ —UN—18OCT88

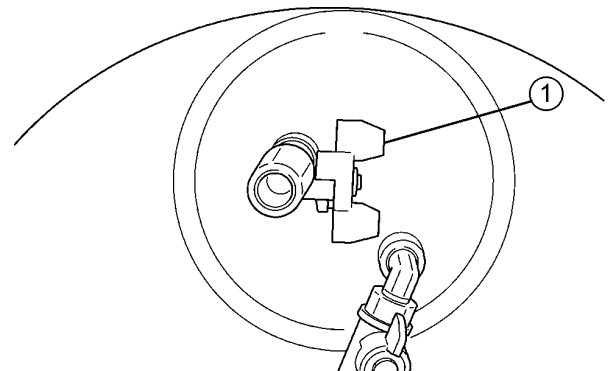

T136406 —UN—18DEC00

ER79617,0000AFA -19-24MAR10-1/1

CLICK HERE TO **DOWNLOAD** THE COMPLETE MANUAL

- Thank you very much for reading the preview of the manual.
- You can download the complete manual from: www.heydownloads.com by clicking the link below



- Please note: If there is no response to CLICKING the link, please download this PDF first and then click on it.

CLICK HERE TO **DOWNLOAD** THE COMPLETE MANUAL

Maintenance—Every 100 Hours

Grease Working Tool Pivots

Grease bucket and link pins (9 points) until grease escapes from joints. Grease every 4 hours for first 20 hours. Grease every 10 hours during first 30—100 hours and when working in mud and water.

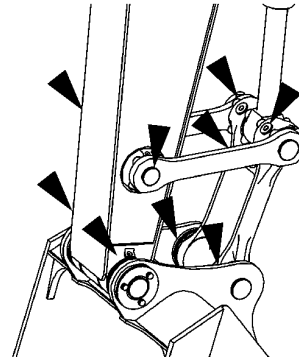

Nine Points

T162242—UN—11DEC02

DW90712.00003AF -19-03JAN07-1/1

Grease Swing Bearing

CAUTION: Prevent possible injury from unexpected machine movement if controls are moved by another person. Lubricating swing bearing and rotating the upperstructure must be done by one person. Before swing bearing is lubricated, clear the area of all persons.

1. Park machine on a level surface.
2. Stop engine.
3. Lubricate swing bearing with 8 shots of grease at both grease fittings.
4. Start engine. Raise bucket several inches off the ground, and turn upperstructure 45 degrees.
5. Repeat steps 2—4 three times.

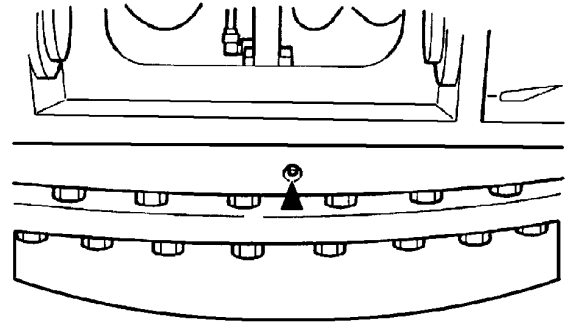

T134968—UN—01NOV00

NOTE: It is not necessary to start the engine the last time.

DW90712,0000323 -19-03JAN07-1/1

Grease Swing Bearing Gear

CAUTION: Prevent possible injury from unexpected machine movement if controls are moved by another person. Lubricating swing bearing gear and rotating the upperstructure must be done by one person.

1. Remove swing bearing gear access cover (1).
2. Grease must be 13—25 mm (1/2—1 in.) deep measured from the bottom of the ring gear. The grease must also be free of contamination by dirt and water.

If the grease is contaminated, remove grease and replace with clean grease.

IMPORTANT: If water or mud is found in swing gear area, see **Operating in Water and Mud.** (Section 2-3.)

3. Add grease as required. When completely dry or after running in mud or water swing bearing gear capacity is approximately 15.4 kg (34 lb).

IMPORTANT: Excessive grease can damage the swing gear case seal.

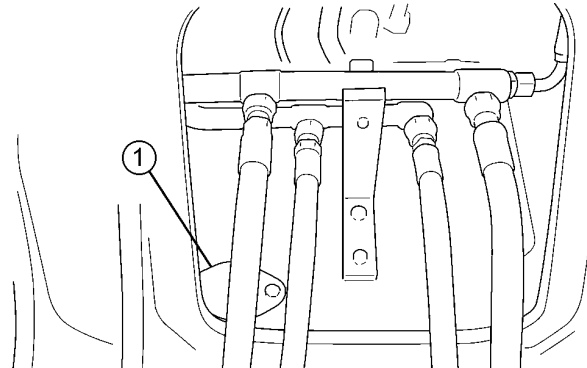

T136458—UN—18DEC00

1— Access Cover

4. Remove any excess grease from over the top of the swing drive pinion.
5. Install access cover.

ER79617,0000AA8 -19-22MAR10-1/1

Replace Air Cleaner Elements

1. Lift lever (1) to unlock cover.
2. Rotate cover counterclockwise, and remove cover.
3. Remove primary element (2).
4. Remove secondary element.
5. Clean the inside of the filter canister.
6. Install elements, making sure the secondary element is centered in canister.
7. Replace cover, and lock by rotating clockwise until "LOCK" symbol is aligned with arrows on body.

1— Lever

2— Primary Element

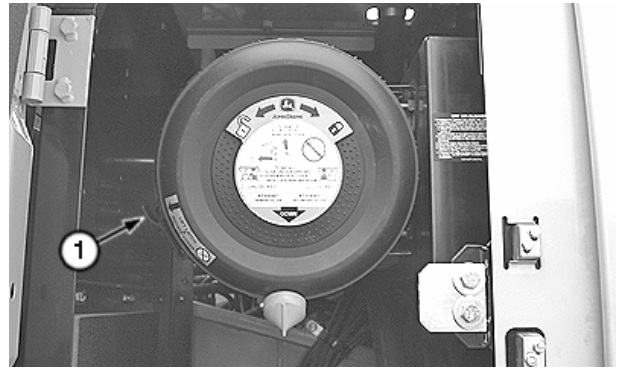

TX1012393A —UN—20SEP06

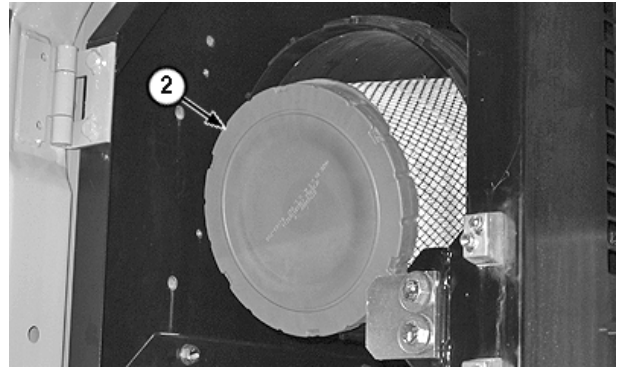

TX1012395A —UN—20SEP06

DW90712,000031A -19-11JAN07-1/1

Replace Air Cleaner Dust Valve

NOTE: A missing, damaged, or hardened dust valve will cause the air filter elements to be ineffective.

Replace dust valve (1).

1— Air Cleaner Dust Valve

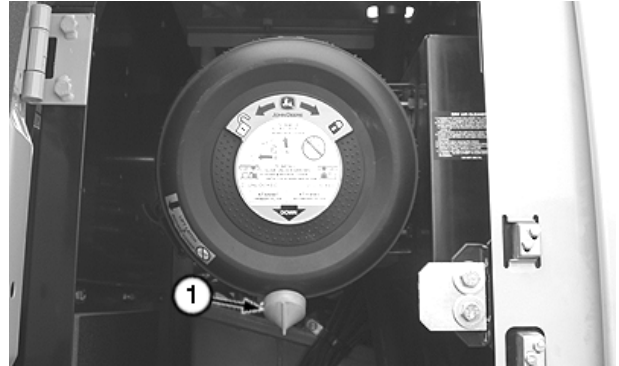

TX1012195A —UN—14SEP06

DW90712,000031B -19-03JAN07-1/1

Check Coolant

See Check Coolant. (Section 3-3.)

OUT4001,0000365 -19-19MAY10-1/1

Cleaning Radiator, Oil Cooler, Charge Air Cooler, A/C Condenser, and Fuel Cooler

CAUTION: Prevent possible injury from rotating fan and flying debris. Shut off engine before opening cover. Avoid rotating fan and fan blast.

1. Turn machine off.
2. Open left rear access door.
3. Remove cap screws (1), and swing out the A/C condenser (2).
4. Use compressed air to clean out the oil cooler (3), radiator (4), charge air cooler (5), and fuel cooler (6).
5. Swing A/C condenser back, and install cap screws.
6. Close left rear access door.

1— Cap Screws (2 Used)
2— A/C Condenser
3— Oil Cooler

4— Radiator
5— Charge Air Cooler
6— Fuel Cooler

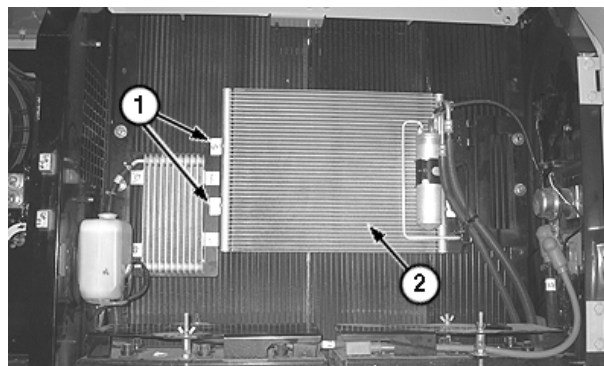

TX1013674A —UN—17OCT06

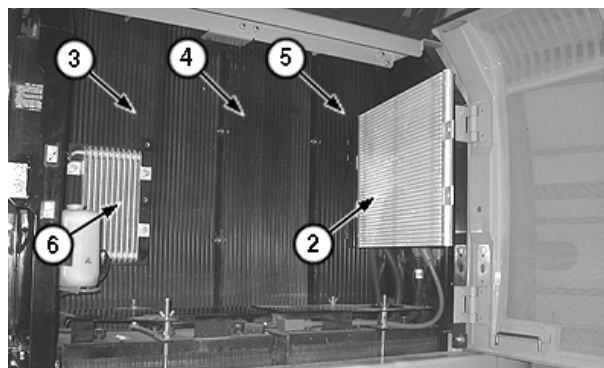

TX1013676A —UN—17OCT06

DW90712,000023F -19-09JAN07-1/2

If machine is equipped with a Hydraulic Reverse Fan Function, use the reverse cooling fan switch to clean the cooling system.

The reversing cooling fan switch has three positions:

- **AUTO:** Every 60 minutes the radiator cooling fan will automatically reverse direction for 15 seconds without intervention from the operator.
- **OFF:** Fan resumes normal operation.
- **MANUAL:** Fan will reverse direction for 15 seconds when right portion of switch is pressed.

NOTE: The reversing fan function shall not be reactivated within 1 minute of its last completion (this time includes "Automatic" cycle).



Reverse Cooling Fan Switch-If Equipped

TX1000844A —UN—29NOV05

DW90712,000023F -19-09JAN07-2/2

Do Not Service or Adjust Injection Nozzles or High Pressure Fuel Pump

If injection nozzles are not working correctly or are dirty, the engine will not run normally. (See your authorized dealer for service.)

Changing the high pressure fuel pump in any way not approved by the manufacturer will end the warranty. (See your copy of the John Deere warranty on this machine.)

Do not service a high pressure fuel pump that is not operating correctly. (See your authorized high pressure fuel pump service center.)

DW90712,00002CF -19-03JAN07-1/1

Replacing Bucket Teeth

CAUTION: Guard against injury from flying pieces of metal; wear goggles or safety glasses.

NOTE: Alternate buckets may use different tooth assemblies.

1. Position bucket in an upward position to access locking pin (1) from the underside of bucket tooth.
2. Drive out locking pin (1).
3. Remove tooth (2).
4. Position bucket level, and place new tooth (2) over tooth shank (3).
5. Drive locking pin (1) in to hole fully.

NOTE: Check bucket teeth periodically so that wear does not extend to the bucket tooth shank.

1— Locking Pin
2— Tooth

3— Tooth Shank

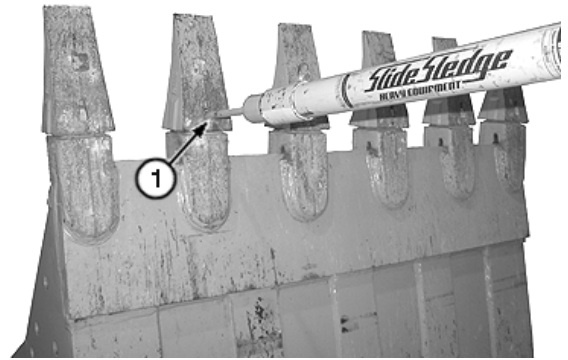

TX1014071A —UN—25OCT06

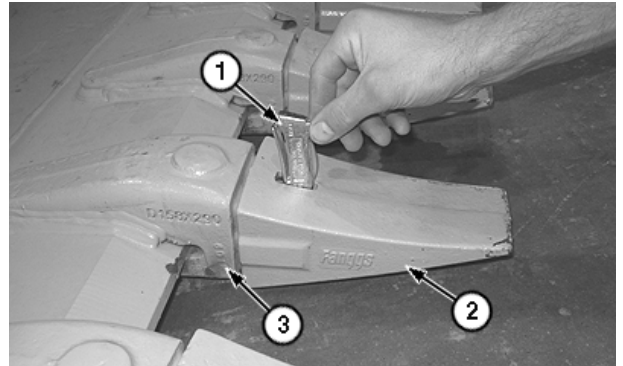

TX1014072A —UN—25OCT06

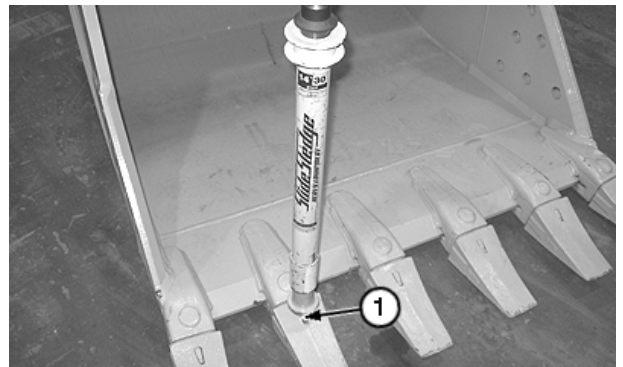

TX1014073A —UN—25OCT06

DW90712,000035A -19-08JAN07-1/1

Windshield Washer and Wiper Circuit Check

IMPORTANT: Washer motor may be damaged if washer switch is held for more than 20 seconds, or continually operated with no fluid in the washer fluid tank.

NOTE: The washer can operate with the upper front window open. The wiper cannot operate with the upper front window open. When closing window, check that window upper left corner makes good contact with the cab.

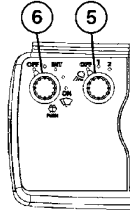

TX1000880 —UN—01DEC05

Switch Panel

- 5— Work Light Switch
- 6— Windshield Wiper and Washer Switch

NOTE: Front window should be fully closed and latched for this check.

Push washer switch (6).

LOOK: Is washer fluid supplied to windshield?

Turn windshield wiper (6) ON.

LISTEN: Does wiper circuit click?

LOOK: Does windshield wiper operate?

YES: Go to next check.

NO: Check washer fluid level. See Windshield Washer Fluid Level. (Section 3-3.)

NO: Check that the window upper left corner is making good contact with the cab.

NO: Check windshield wiper and washer 10 A fuse (F2) (Marked WIPER). See authorized dealer.

ER93822,00001DF -19-06APR10-13/42

Operational Checks—Key Switch ON, Engine ON Checks

Continued on next page

ER93822,00001DF -19-06APR10-14/42

Hydraulic Oil Tank Pressurization Check

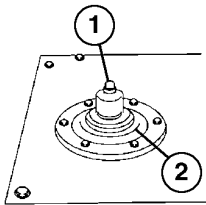

TX1000859 —UN—01DEC05

Hydraulic Oil Tank Cover

- 1— Hydraulic Oil Tank Pressure Release Button
- 2— Hydraulic Oil Tank Cover

Raise boom to full height, then lower boom to ground.

Slowly depress pressure release button on hydraulic oil tank cover.

LISTEN: Is air heard escaping from the pressure release button on hydraulic oil tank cover?

IMPORTANT: The pressurized oil tank creates pressure at the inlet to the hydraulic pumps. If tank cover does not seal, hydraulic pumps could cavitate and be damaged.

YES: Go to next check.

NO: Replace hydraulic oil tank cover.

ER93822.00001DF -19-06APR10-24/42

Swing Dynamic Braking Check

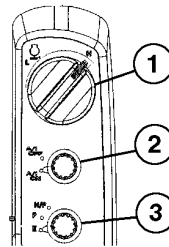
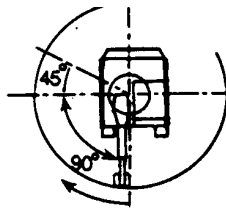

- 1— Engine Speed Dial
- 2— Auto-Idle Switch
- 3— Power Mode Switch

CAUTION: Make sure area is clear and large enough to swing extended arm and bucket. Machine must be on level ground.

Position upperstructure with boom to the front.

Move arm to the extended position, bucket to the retracted position, and bucket-to-arm pivot pin at same level as boom-to-frame pivot pin.

Turn engine speed dial (1) to H (fast idle) position.

Turn power mode switch (3) to P (power) mode.

Fully actuate swing function. Swing right 90 degrees and then release lever.

LOOK: Does upperstructure stop within 45 degrees (1/8 turn) or less after releasing lever?

Position upperstructure with boom to the front.

Fully actuate swing function. Swing left 90 degrees and then release lever.

LOOK: Does upperstructure stop within 45 degrees (1/8 turn) or less after releasing lever?

YES: Go to next check.

NO: See authorized dealer.

Continued on next page

ER93822.00001DF -19-06APR10-25/42

**Travel System
Maneuverability Check**

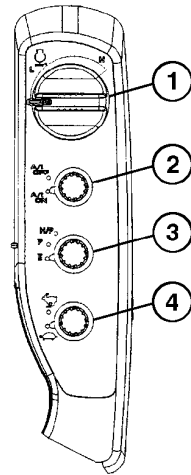

TX1000744 —UN—29NOV05

Switch Panel

- 1— Engine Speed Dial**
- 2— Auto-Idle Switch**
- 3— Power Mode Switch**
- 4— Travel Speed Switch**

Turn engine speed dial (1) to H (fast idle) position.

Turn travel speed switch (4) to fast speed (rabbit) mode.

Drive machine at full speed forward down a slope.

Turn in each direction.

LOOK: Does each track slow down in response to pedal or lever movement in order to turn?

Repeat the procedure in reverse travel.

Turn travel speed switch (4) in fast speed (rabbit) mode.

Drive machine at full speed in reverse down a slope.

Turn in each direction.

LOOK: Does each track slow down in response to pedal or lever movement in order to turn?

YES: Go to next check.

NO: See authorized dealer.

Continued on next page

ER93822,00001DF -19-06APR10-38/42

Miscellaneous—Troubleshooting

Symptom	Problem	Solution
	Battery or starter cable connections loose or corroded	Clean and tighten connections.
	Battery discharged or will not hold a charge	Recharge or replace both batteries.
	Starter	Repair or replace starter.
	Low battery voltage	Recharge or replace both batteries.
Starter Continues To Run After Engine Starts	Starter	Repair or replace starter.
	Key switch malfunction	Disconnect battery ground. Replace key switch.
Charging Indicator Light On, Engine Running	Loose or glazed alternator belt	Check belt. Replace if glazed.
	Loose or corroded electrical connections on battery, ground strap, starter, or alternator	Inspect, clean, or tighten electrical connections.
	Fuse	Check Controller Key Switch Signal 10 A Fuse (Marked POW ON), and replace if necessary.
Noisy Alternator	Worn drive belt	Replace belt.
	Worn pulleys	Replace pulleys and belt.
	Pulley misaligned	Adjuster alternator mount.
	Alternator bearing	Loosen alternator belts. Turn pulley by hand. If any roughness is felt, repair alternator.
No Monitor Panel Indicators Or Gauges Work	Fuse	Check Controller Key Switch Signal 10 A Fuse (Marked POW ON), and replace if necessary.
No Switch Panel Switches Or Engine Speed Dial Work	Fuse	Check Monitor Controller Power 5 A Fuse (Marked SW. BOX), Information Controller and Main Controller Battery Power 5 A Fuse (Marked C/U), Work and Drive Lights 20 A Fuse (Marked LAMP), Windshield Wiper and Washer 10 A Fuse (Marked WIPER), and Solenoid 10 A Fuse (Marked SOLENOID), and replace if necessary.

DW90712,0000371 -19-03JAN07-2/2

Drain and Refill Capacities

Item	Measurement	Specification
Fuel Tank	Capacity	400 L 105.7 gal
Cooling System	Capacity	26 L 6.9 gal
Engine	Oil Capacity, Including Filter Change	22.7 L 6.0 gal
Hydraulic Tank	Oil Capacity	135 L 36 gal
Hydraulic System	Oil Capacity	240 L 63.4 gal
Swing Gear Case	Oil Capacity	6.2 L 1.6 gal
Travel Gear Case (each)	Oil Capacity	6.8 L 1.8 gal
Pump Drive Gear Case	Oil Capacity	1 L 1.1 qt

ER79617,0000AAF -19-22MAR10-1/1

Lift Capacity—Arm: 2.41 m (7 ft 11 in.), Shoe: 700 mm (28 in.)

Arm: 2.41 m (7 ft 11 in.)	Bucket: 723 kg (1590 lb) 0.86 m ³ (1.12 yd ³)	Shoe: 700 mm (28 in.)
---------------------------	--	-----------------------

Ratings are at bucket lift hook, using standard counterweight, situated on firm, level, uniform supporting surface.

Figures do not exceed 87 percent of hydraulic capacity or 75 percent of weight needed to tip machine. Figures marked with an (a) are hydraulically-limited capacities. Remaining figures are stability-limited capacities.

Power Dig: On

200D Lift Capacity—KG (LB)					
LIFTING OVER FRONT					
Load Point Height	Horizontal Distance From Centerline of Rotation				
m (ft)	1.52 (5)	3.05 (10)	4.57 (15)	6.10 (20)	7.62 (25)
6.10 (20)				^a 4133 (9111)	
4.57 (15)			^a 5130 (11 309)	^a 4490 (9898)	^a 4256 (9383)
3.05 (10)			^a 6991 (15 412)	^a 5258 (11 591)	4427 (9759)
1.52 (5)				^a 6088 (13 421)	4302 (9484)
Ground Line			^a 9358 (20 630)	5924 (13 061)	4204 (9268)
-1.52 (-5)			^a 9097 (20 056)	5853 (12 903)	4171 (9195)
-3.05 (-10)		^a 9169 (20 215)	^a 8198 (18 073)	5894 (12 995)	
-4.57 (-15)		^a 8069 (17 789)	^a 6295 (13 877)		
LIFTING OVER SIDE					
m (ft)	1.52 (5)	3.05 (10)	4.57 (15)	6.10 (20)	7.62 (25)
6.10 (20)				^a 4133 (9111)	
4.57 (15)			^a 5130 (11 309)	4330 (9546)	2916 (6429)
3.05 (10)			6365 (14 033)	4094 (9025)	2829 (6236)
1.52 (5)				3846 (8480)	2713 (5982)
Ground Line			5605 (12 358)	3678 (8108)	2623 (5783)
-1.52 (-5)			5582 (12 306)	3614 (7967)	2593 (5716)
-3.05 (-10)		^a 9169 (20 215)	5662 (12 482)	3651 (8049)	
-4.57 (-15)		^a 8069 (17 789)	5866 (12 933)		

^aHydraulically-limited capacity

200DLC Lift Capacity—KG (LB)					
LIFTING OVER FRONT					
Load Point Height	Horizontal Distance From Centerline of Rotation				
m (ft)	1.52 (5)	3.05 (10)	4.57 (15)	6.10 (20)	7.62 (25)
6.10 (20)				^a 4083 (9001)	
4.57 (15)			^a 5086 (11 212)	^a 4443 (9795)	^a 4208 (9278)
3.05 (10)			^a 6959 (15 341)	^a 5216 (11 500)	^a 4467 (9847)
1.52 (5)				^a 6051 (13 340)	^a 4843 (10 677)
Ground Line			^a 9338 (20 586)	^a 6592 (14 533)	4774 (10 525)
-1.52 (-5)			^a 9076 (20 010)	^a 6654 (14 669)	4740 (10 450)
-3.05 (-10)		^a 9169 (20 215)	^a 8175 (18 022)	^a 6098 (13 444)	
-4.57 (-15)		^a 8057 (17 763)	^a 6265 (13 813)		
LIFTING OVER SIDE					
m (ft)	1.52 (5)	3.05 (10)	4.57 (15)	6.10 (20)	7.62 (25)
6.10 (20)				^a 4083 (9001)	
4.57 (15)			^a 5086 (11 212)	^a 4443 (9795)	3220 (7099)
3.05 (10)			^a 6959 (15 341)	4536 (10 000)	3133 (6907)
1.52 (5)				4290 (9457)	3019 (6655)
Ground Line			6338 (13 972)	4120 (9084)	2928 (6456)

Continued on next page

ER93822.00001D6 -19-17JUN08-1/2

CLICK HERE TO **DOWNLOAD** THE COMPLETE MANUAL

- Thank you very much for reading the preview of the manual.
- You can download the complete manual from: www.heydownloads.com by clicking the link below



- Please note: If there is no response to CLICKING the link, please download this PDF first and then click on it.

CLICK HERE TO **DOWNLOAD** THE COMPLETE MANUAL