

Energy Harvester 1490D Serial Number WJ1490D002030-

OPERATOR'S MANUAL 1490D Energy Harvester

OMF069420 Issue 01JUN05 (ENGLISH)

CALIFORNIA
Proposition 65 Warning

Diesel engine exhaust and some of its constituents are known to the State of California to cause cancer, birth defects, and other reproductive harm.

If this product contains a gasoline engine:

 **WARNING**

The engine exhaust from this product contains chemicals known to the State of California to cause cancer, birth defects or other reproductive harm.

The State of California requires the above two warnings.

CLICK HERE TO **DOWNLOAD** THE COMPLETE MANUAL

- Thank you very much for reading the preview of the manual.
- You can download the complete manual from: www.heydownloads.com by clicking the link below



- Please note: If there is no response to CLICKING the link, please download this PDF first and then click on it.

CLICK HERE TO **DOWNLOAD** THE COMPLETE MANUAL

Warranty

Standard warranty clauses

The machine is covered by manufacturer's guarantee in compliance with the standard warranty clauses accepted by the John Deere Forestry Group.

The manufacturer will not assume responsibility for the machines delivered should the following conditions be violated:

- The machine is exclusively operated and maintained by experienced personnel who have been trained by

the manufacturer or by a dealer authorized by the manufacturer.

- The machine must be operated and maintained in accordance with the instructions provided in this manual.
- Only fuels, lubricants and washing fluids specified in this manual are used.
- Only genuine spare parts are used

EL62757,000015D -19-04MAY05-1/1

Standard Warranty

12 Months Warranty Full Machine Coverage to 2000 hr. on all John Deere forestry machines.

The warranty given by manufacturer will be valid provided that the machine is handed over for following maintenances at the service shop authorized by John Deere:

- Pre Delivery Inspection (PDI)
- 250 hours maintenance
- 1000 hours maintenance.

From here after we recommend *service every 1000 hours*, done by authorized workshop.

EL62757,000015E -19-19APR02-1/1

Machines with Extended Coverage (For specified machines only!)

EXTENDED COVERAGE is a purchased coverage program sold by authorized dealers. It provides additional coverage beyond the Standard Warranty provided with the new machine.

The Extended Coverage will be valid provided that the machine is handed over for following maintenances at the service shop authorized by John Deere:

- Pre Delivery Inspection (PDI)¹
- 250 hours maintenance¹
- 1000 hours maintenance¹.

There after service every 1000 hours, done by authorized workshop, *as long as the coverage period lasts*.

¹the same as in Standard Warranty

EL62757,0000001 -19-04MAY05-1/1

Secondary exit

There is an emergency exit through the front right hand side window.

IMPORTANT: Remove the lock pin (1) from behind the window latch before you start to work.

CAUTION: Always remember to remove the lock pin before you start the machine. If not, the window can't be opened from the outside in case of emergency.

IMPORTANT: In case of emergency the window can be opened from outside and inside.

From the inside : Pull the hinge pin (2) entirely out and push the window fully open.

From the outside (the lock pin has to be removed): Push in the releasing handle (3). The window can be opened so much that you are able to pull the hinge pin (2) out and open the window fully.

IMPORTANT: Replace the lock pin (1) again when locking the cab. That is to prevent unauthorized access to the cab through the window

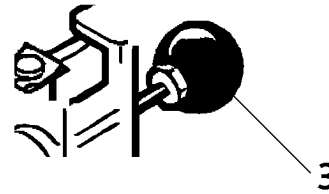
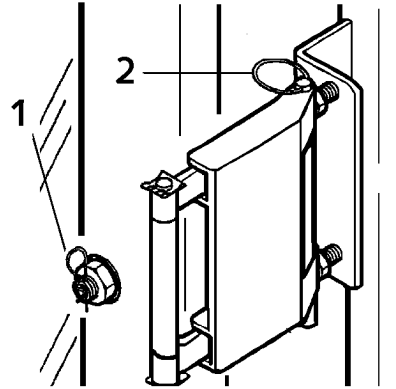

T152785 -UN-06APR03

EL62757_0000165 -19-19APR02-1/1

Precautions while maintaining the Bundler Unit

- Never modify the hydraulic system to speed up the chain rotation
- When washing the machine with pressurized water, be careful with the electrical components. Make sure no water gets inside.
- Take care to remove any snow or ice, twigs and bark from the area around the cutting equipment
- Never adjust hydraulic pressure without a manometer.
- Inspect the condition of the saw and its mountings, and check that there is no leakage or other faults



CAUTION: When working with the saw chain, always make sure that the engine is turned off.

Use protective gloves.

Always remove the saw chain when adjusting or servicing the saw unit.

- Avoid breathing in oil, colour marking dye or stump treatment fluid fumes.

NOTE: The machine may be repaired and maintained only by trained personnel or an authorized service workshop with proper tools and hoisting device.

EL62757,0000237 -19-04DEC02-1/1

Operator's Station

General

Warning lights are located on the front dashboard.

Bear in mind that should a warning light go on or the central warning light blink, this always indicates that there is something that does not function properly within the system. This being the case, discontinue loading and turn off the engine. See the Instructions for use of TMC™ (Total Machine Control), Appendix.

The operation of the alarm system is detailed in the Instructions for use TMC™.

- 1—Front dashboard
- 2—Signal lights
- 3—TMC-display
- 4—Left control panel
- 5—Right control panel
- 6—Drive pedal
- 7—Brake pedal
- 8—Heater/AC controls
- 9—Warning lamps
- 10—Light switch
- 11—Engine preheater
- 12—Control unit for fire extinguisher system
- 13—Radio

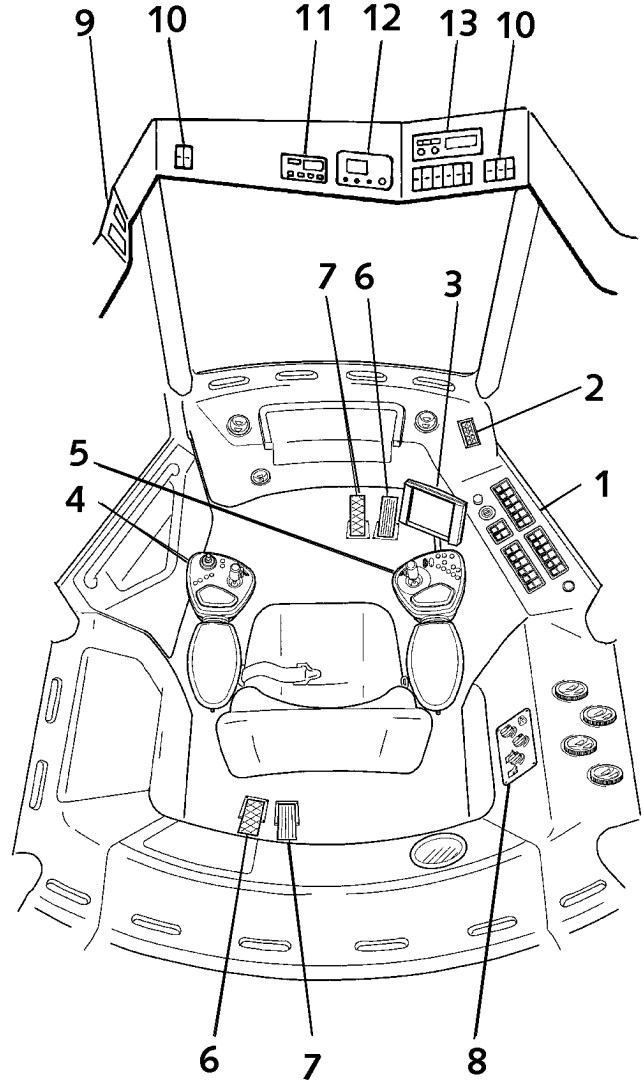

Cab Component Locator

T152190 -UN-12SEP02

TMC is a registered trade mark

EL62757,000016C -19-19APR02-1/1

Air Conditioner Controls

Instructions for use, see section 12-1.

- 1—Fan speed
- 2—Temperature control
- 3—Inside air recirculation / outside air brought in; selector switch (For the outside air, turn the switch clockwise to its extreme position)
- 4—Air vent control
- 5—Max. defrost (eliminates humidity)

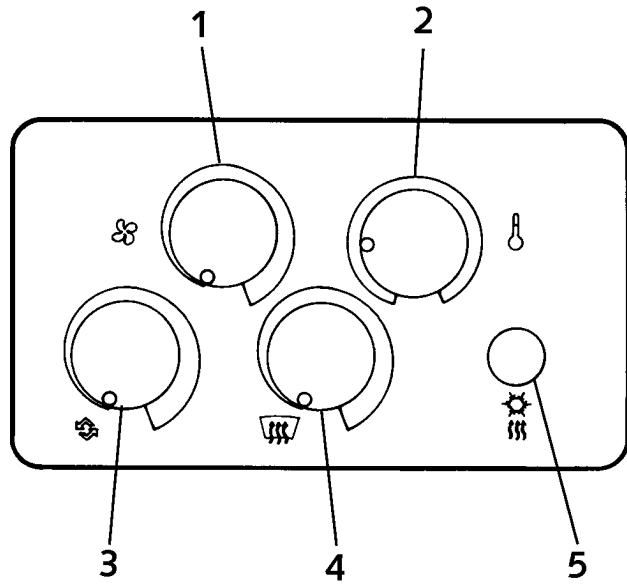

T152201 -UN-02OCT02

EL62757,0000177 -19-19APR02-1/1

Engine Heating Timer (Opt. Eq.)

Instructions for use, see section 12-2

- 1. Time
- 2. Program
- 3. Heating on
- 4. Backwards
- 5. Forwards
- 6. Memory indicator
- 7. Weekday / program day
- 8. Symbol for remote control (opt.eq.)
- 9. Time display
- 10. Temperature display (opt.eq.)
- 11. Status display

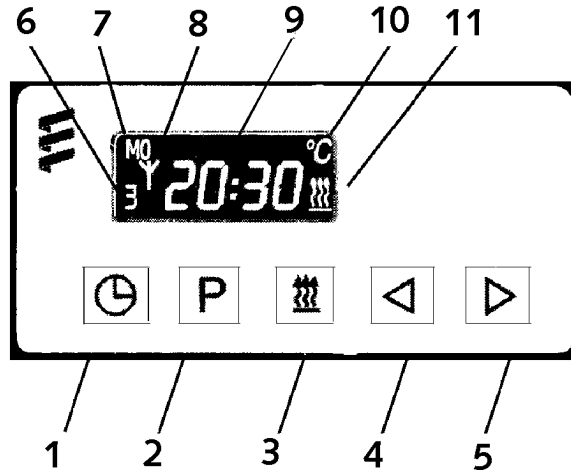

T153141 -UN-03OCT02

EL62757,0000381 -19-21FEB03-1/1

Lifting and Lowering the Cab

How to Lift the Cab

IMPORTANT: See to it that nobody comes too close to the machine when you lift or lower the cab.

1. Remove the cab attaching bolts (1).
There is one bolt for each cab corner
2. Turn the up/down valve (2) clockwise until it stops in the extreme position.
3. Pump up the cab by means of the lever (3) until it does not rise anymore.
4. Secure the cab with the lock bar (4) before you start working under the cab

IMPORTANT: Do not lift the cab if the machine is not standing on level ground. Do not drive the machine if the cab is in the upper position. You can run the engine while the cab is up (if you are adjusting the pressures, for instance).

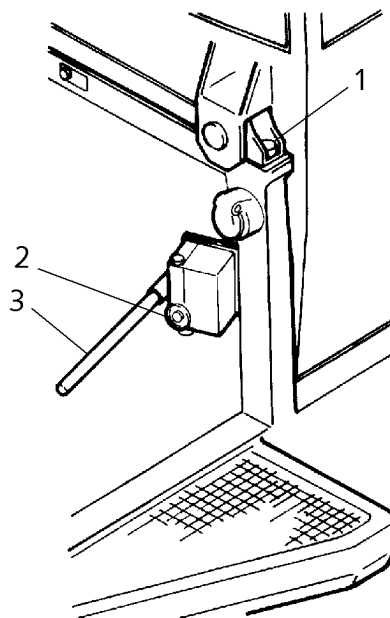

- 1—Attaching bolts
- 2—Up/down valve
- 3—Pumping lever

T152216 -UN-05MAR02

EL62757,0000187 -19-21APR02-1/1

5. If the switch of the high/low gear is pressed after the driving direction has been selected, the system will move to the adjustable speed range (%). What will be shown as a speed range symbol on the TMC display is a snail underneath of which can be seen the driving speed setting. Speed can be adjusted through the Z movement of the right minystick.
6. The machine is steered by means of the minystick of the left control panel.

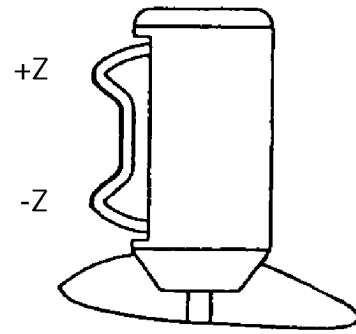
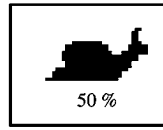

T152214 -JUN-05MAR02

Off-Road Driving with the Working rpm off

If you do not want to use the working rpm in off-road driving, the operation is similar to what has been described above, but:

- Regulating the machine speed with the drive pedal has a direct impact on the speed of the diesel engine
- You cannot operate the boom.

EL62757,0000192 -19-21APR02-3/3

Driving on Road

The high gear can be used for driving on road. This is when the rear-wheel drive is disengaged.

However, it is possible to engage the rear-wheel drive with a separate switch.

NOTE: The high gear cannot be engaged if the seat is facing the back of the machine.

1. Disengage working rpm.

Continued on next page

EL62757,0000193 -19-21APR02-1/3

Capacities

Fluids and lubricants	Liters	Gallons
Engine oil + filter	25	6.6
Coolant	27,5	7,1
High/low gear	4,5	1,2
Differential; single axle (6-wheeled)	30	7,9
Differential; rear	12	3.2
Differential; front - 8-wheeled	12	3.2
Hub gearings / each	4	1
Bogie housing / each	50	13
Loader slew housing	7	1,8
Hydraulic fluid	150	40
Fuel tank	165	43.5
Windshield washer fluid tank	2 x 5	2 x 1,3
Cab lift fluid	0,8	0,2
Driving brake oil level (ATF oil)	0,4	0,1
Air conditioner system	1,5 kg	0,4
Air Conditioner Compressor (PAG Oil)	0,05	0,01

EL62757,000014F -19-18APR02-1/1

Using the Frame Lock

CAUTION: Prevent unexpected machine movement and possible injury. Install frame locking pin before you work in frame pivot area.

Installing the Frame Lock Bar

1. Remove screw and locknut from pin. Remove the pin.
2. Swing the locking bar across the articulation. Install the bar on the bracket on the front frame.

Install the pin.

3. If pin cannot be installed, start engine, and gently use the steering to adjust the frame positions.
4. Install the screw and locknut on the pin.

Removing Frame Lock Bar

1. Remove screw and locknut from pin.
2. Remove the pin.

IMPORTANT: When removing frame locking pin, use steering gently to prevent damage to machine frame.

3. If pin cannot be removed, start engine, and gently use the steering to adjust the frame positions.
4. Install frame locking bar on the storage bracket on the rear frame. Install the screw and lock nut on the pin.

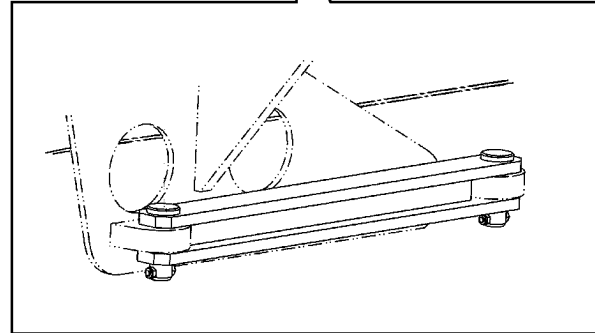
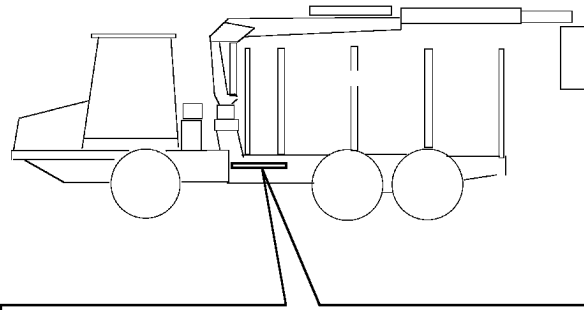

1—Frame Locking Bar

T144061 -JN-18JUL01

OUTJ003,0000675 -19-14MAY01-1/1

Service Parts

Part	Part number	10h	50h	250h	500h	1000h	2000h	Note!
A/C dryer filter	F052188		**	**	**	**	**a	See section 12-1
Air cleaner, safety element	F044979	**	**	**	**	**	**	
Air cleaner, filter element	F044978	**	**	**	**	**	**	
Alternator belt	R500385		**	**	**	**	**	
Battery	F058325				**	**	**	
Oil filter + packing	RE504836 + R502513			X	X	X	X	
Copper washers (differentials, bogie housings, planetary gears)	F009463 F009465 F018108			X	X	X	X	See Parts Catalog
Transmission pump filter	F058437				X	X	X	
Fresh air filter	F026833			**	**	**	**	
Fuel filter	RE509031 (final), RE517181 (primary-)				X	X	X	+ 2 pcs R113565
Hydr. reservoir return filter, O-ring	F061786, F003308					X	X	
Hydr. reservoir breather	F062132					X	X	
Venttiilikopan tiivisteet	R123543					**	**	+ 6 pcs R123575
Engine oil	See Fluids and Lubricants	x	x	x	x	x	x	25 l
Distillered water				**	**	**	**	
Drive brake oil	See Fluids and Lubricants	**	**	**	**	**	**	ca. 0.5 l
Grease	See Fluids and Lubricants		X	X	X	X	X	
Hydraulic Oil	See Fluids and Lubricants	**	**	**	**	**	**	150 l
Gear Oils	See Fluids and Lubricants			**	**	X	X	
Coolant	See Fluids and Lubricants. See maintenance every 2000 hours.	**	**	**	**	**	**	27,5 l
Cab lift oil	See Fluids and Lubricants	**	**	**	**	**	**	ca. 0.8 l
Windshield washer fluid	See Fluids and Lubricants	**	**	**	**	**	**	2 x 5 l
Saw chain	F300859	**	**	**	**	**	**	
Saw bar	F624571	**	**	**	**	**	**	

^achange / add when necessary

Continued on next page

EL62757,0000145 -19-18APR02-1/2

The following service and checks are to be made at the end of each workday

- Clean the machine
 - Inspect all covered compartments, including engine bay, belly plates etc. It is particularly important to clean the machine in the winter because snow and debris easily gets stuck to the machine
- Make sure that there are no defects or leaks
 - Check the machine in daylight
 - Repair any defects found or contact the service personnel.
- Renew oils and grease (if necessary) the machine while it is still warm.
- Check the tightness and mounting of the possible chains.
- Replace the lock pin of the emergency exit
- Lock the cab door
- Turn off the main switch.
 - If the machine is equipped with an automatic fire extinguishing system (optional equipment), the system will be engaged when the main switch is turned off.

EL62757,00000FD -19-10APR02-1/1

Maintenance - Every 500 hours

Change engine oil and replace oil filter

IMPORTANT: Change the engine oil and filter for the first time after 250 hours maximal of operation, then every 500 hours thereafter.

Capacities	Engine oil + filter	25 l (6.6 gal)
John Deere PLUS-50, ACEA E5, ACEA E4. See also chapter 6-1.		

1. Run engine approximately 5 minutes to warm up oil. Shut engine off.
2. Lower the belly pan. Open the plug of the drain hose (3) and drain the oil into a container.

3. Oil filter (A) is placed at the right side of the engine.

Clean the area around the filter bowl.

4. Remove old oil filter element turning it counterclockwise. Make sure the old seling comes off with filter. Clean the sealing surface of the filter foot.

IMPORTANT: Filtration of oils is critical to proper lubrication. Always change filter regularly. Use filter meeting John Deere performance specifications

5. Oil new packing and the sealing of the filter using clean engine oil. Turn the filter element back and tighten 3/4...1-1/4 turn after packing contacts filter housing.

6. Install oil pan drain plug (3) with a new seal when equipped.

Specification

Oil pan drain plug—Torque..... 80 Nm (59 lb-ft)

7. Fill engine crankcase with engine oil through oil filler cap.

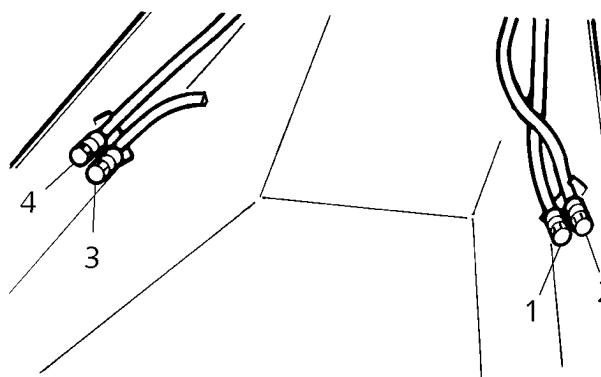

T152229 -UN-05MAR02



RG11616 -UN-24OCT01

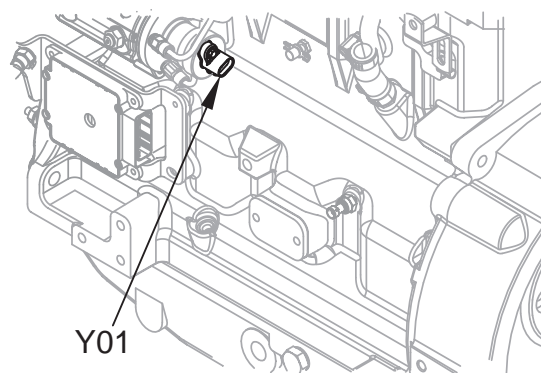

T160264 -UN-08OCT02

3—Oil drain hose
A—Oil filter

Continued on next page

DPSG,OUOE003,8005 -19-18JUN99-1/2

Maintenance - Every 1000 hours

Renew the hydraulic oil.

NOTE: Change hydraulic oil when it is warm and contaminants are in suspension.

You can use a vacuum pump (optional equipment) to drain the hydraulic tank. The vacuum pump is used to avoid oil spill, e.g., in the event of hose rupture or other leakage. See section 7-1 for instructions to use a vacuum pump.

You can use a hydraulic fill-up pump (optional equipment) to add oil to the tank. Oil is added through a quick coupler which is mounted in a way that the new oil enters the system through the filter. Also a manual pump can be used.

See section 7-1 for instructions to renew the hydraulic oil.

IMPORTANT: Do not mix oils.

EL62757,00000EC -19-10APR02-1/1

Changing the Coolant

CAUTION: Explosive release of fluids from pressurized cooling system can cause serious burns.

Shut off engine. Only remove filler cap when cool enough to touch with bare hands. Slowly loosen cap to first stop to relieve pressure before removing completely.

NOTE: Drain the initial factory fill engine coolant after the first 3000 hours or 3 years of operation. Subsequent drain intervals are determined by the coolant used for service.

When John Deere COOL-GARD is used, the drain interval is 3000 hours or 3 years. The drain interval may be extended to 5000 hours or 5 years of operation **provided that the coolant is tested annually AND additives are replenished as needed, by adding a supplemental cooling additive (SCA).**

If COOL-GARD is not used, the drain interval is reduced to 2000 hours or 2 years of operation.

Drain old coolant, flush the entire cooling system, replace thermostats, and fill with recommended clean coolant.

1. Make sure that the machine is standing horizontally. Set the cabin heating control to its maximum open position.
2. Carefully open the expansion tank cap to relieve pressure and allow coolant to drain faster.
3. Open engine block drain valve (A) on left side of engine. Drain all coolant from engine block. Open radiator drain valve (C) and drain coolant from radiator.
4. Remove thermostats. Install cover and tighten cap screws to 20 Nm (15 lb-ft).
5. Close all drain valves and fill the cooling system with clean water. Run the engine about 10 minutes to stir up possible rust or sediment.



High Pressure Fluids

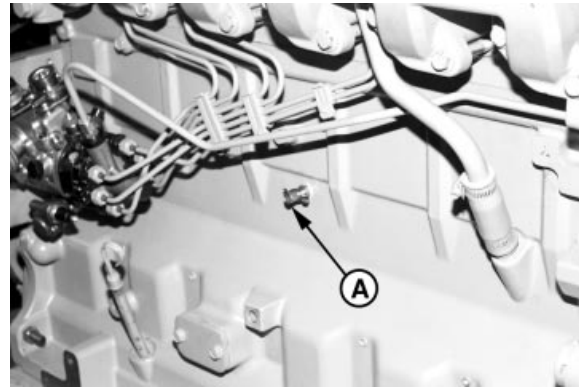

Cooling System Drains

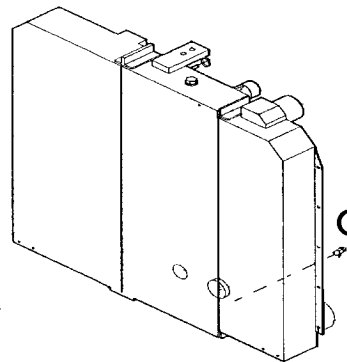

A—Pump Drain Valve
C—Radiator Drain Valve

Maintenance - As required

General

IMPORTANT: Do not modify fuel system!



CAUTION: Modification or alteration of the injection pump, the injection pump timing, or the fuel injectors in ways not recommended by the manufacturer will terminate the warranty obligation to the purchaser. In addition, tampering with fuel system which alters emission-related equipment on engines may result in fines or other penalties, per EPA regulations or other local emission laws. Do not attempt to service injection pump or fuel injectors yourself. Special training and special tools are required. (See your authorized servicing dealer or engine distributor.)

EL62757,000013C -19-11APR02-1/1

Bleeding Drive Hydraulic System

Air must be eliminated from the drive hydraulics after the system has been serviced or repaired, before the machine is used again.

1. If necessary, add first clean, filtered hydraulic oil to the housings of the drive pump and drive motor through the bleed connects (B), until the housings are half full.
2. Fill up the hydraulic tank.
 - Make sure that the low-pressure hose of the drive pump is also filled with oil (loosen the hose connector for the fill-up).

B—Drive pump bleed connect, Drive motor bleed connect

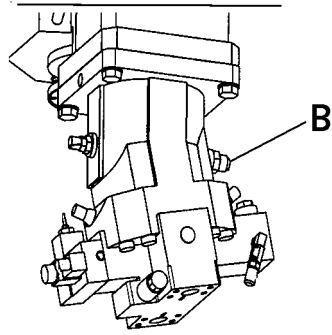

T159885 -JUN-19FEB03

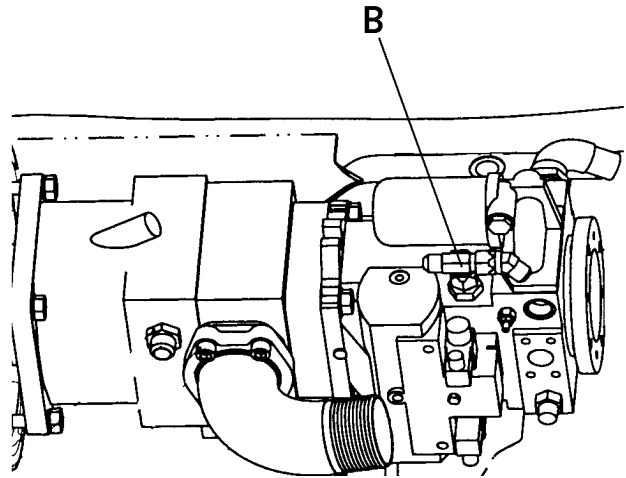

T165127 -JUN-22MAR04

Continued on next page

EL62757,000019A -19-21APR02-1/2

CLICK HERE TO **DOWNLOAD** THE COMPLETE MANUAL

- Thank you very much for reading the preview of the manual.
- You can download the complete manual from: www.heydownloads.com by clicking the link below



- Please note: If there is no response to CLICKING the link, please download this PDF first and then click on it.

CLICK HERE TO **DOWNLOAD** THE COMPLETE MANUAL

Checking and adjusting drive motors pressure cut-off settings

The tools needed: 3-mm hex key and 10-mm wrench

1. Disconnect the parking brake solenoid Y41 from the valve block. After this, the parking brake will stay engaged.
2. Connect a pressure sensor to measuring point (206) (...60 MPa) (0...8702 psi) and a pressure gauge to measuring point (216) (...60 MPa) (0...8702 psi)
3. Disconnect the connector of the motor steering (pos. C)
4. Connect a 24 V tension with a separate cable from the power outlet next to the main switch to the motor steering (pos.C).
5. Start the engine
6. Engage high gear and rear wheel drive. Let the engine idle.
7. Select the driving direction forward.
8. Set the adjustable speed range (snail) to 15 %
9. Press smoothly the drive pedal, the pressure will first start to rise at measuring points (216) and (206).
10. The engine rpm and the pressures are increasing, but at a certain point the pressure of (216) stops to increase and finally it starts to decrease.
11. When the pressure at (206) reaches 36 MPa (5221 psi) the pressure at (216) should then be 14 ± 2 MPa (2030 ± 290 psi).
 - a. If (206) reaches 36 MPa (5221 psi) and the value at (216) is **higher** than 14 ± 2 MPa (2030 ± 290 psi) , turn the adjusting screw (217) counterclockwise in small increments and repeat the test.

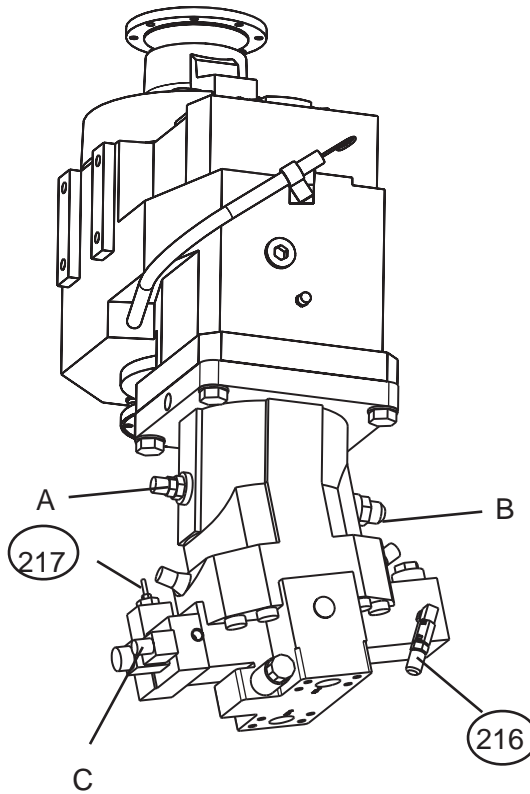

T152684 -UN-19MAR02

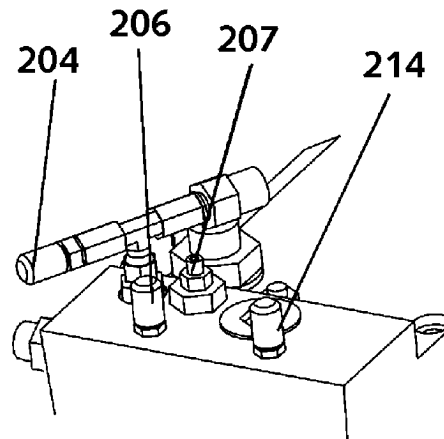

T153143 -UN-19FEB03

C—Adjusting screw
 (216)—Measure point, cut-off
 (217)—Adjusting screw, cut-off

Adjusting Optional Equipment

- Decking blade

All optional equipment (as installed at the factory) operate with the maximum pressure. *There are no separate pressure adjustments.*

EL62757,00001A6 -19-21APR02-1/1

- disconnect ECU's cable
- disconnect Hub's cables (5 cables)

2. Grounding

- Connect the ground wire as close to the welding point as possible.
- The welding current must never pass through bearings, joints, electrical equipment, or hydraulic systems.

3. The parts that must never be welded:

- boom fastening bolts
- control valves
- hydraulic pipes

4. The parts that must not be welded without the manufacturer's instructions:

- castings
- cylinder loops.

5. The points and components to which it is forbidden to attach other parts by welding:

- castings
- boom ends
- cylinder fastening lugs
- corners of box girders

6. Welding.

Weld inside, if possible, in facilities reserved for this purpose where the temperature is at least 10 degrees centigrade. If welding in other places, pay attention to local regulations and to circumstances as well as to the environment before you start welding.

The welder must possess adequate skills and the permits required.

7. Assessment of damage.

In case a component or structure has been damaged as a result of an accident, excessive load, or fatigue, it is first necessary to determine whether the structure requires reinforcements or is ordinary repair sufficient.

8. Instructions.

Before you start welding you can also contact the manufacturer who has detailed instructions for each case.

Possibility of major damage is reduced by regularly cleaning and checking the machine and the boom.

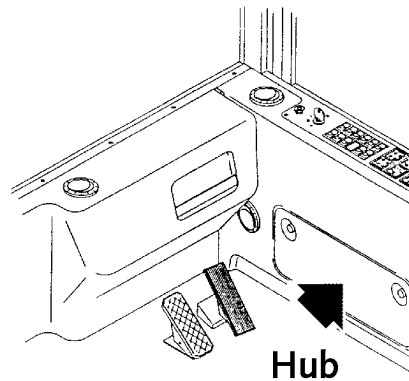
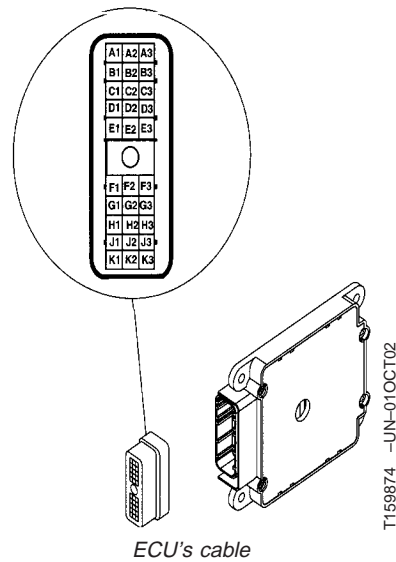

Hub in the cabine

T159362 -UN-13SEP02

General Operating Instructions

First, operate the loader smoothly without load in order to allow the grease to warm up and a coherent lubrication film to be formed in loader joints.

During Operation:

1. Observe the lifting ratings given on the loader decal. The weight of the lifting equipment is included in the load to be lifted.
2. When handling a maximum load, exercise great caution.
3. Operate the control sticks smoothly; avoid jerky movements
4. Exercise extra caution always when a boom or the booms are in their extreme positions.
5. Keep an eye on machine stability.
 - a. Constant alertness is required particular when operating on sloping ground.
 - b. If necessary, lift small loads only
 - c. When you notice that the machine is about to fall over, pull all extensions in, bend the outer boom, and lower the load smoothly onto the ground.
6. When handling a load proceed as follows
 - a. Lift the load up

- b. Move it closer to the machine.
- c. Slew it.
- d. Lower the load down.

7. It is possible that you exceed the lifting capacity of the loader (the booms will sink) if you pick up a load that is close to the machine and move the load away from the machine. When this happens you must bring the load closer to the machine by pulling the outer boom or extension inwards. This is necessary because otherwise the power of the main boom cylinder will not be sufficient to handle the load.

When Loading Is Over:

1. Carry out the last movements unloaded
2. Lower the booms (and also the center of gravity) onto the load, as down as possible.
3. Close the grapple around the load or frame in order to prevent the loader from moving sideways.
4. Do not ever leave the loader unsupported by relying on the hydraulic system only.
5. When you drive the machine from one place to another make sure that the loader does not make any sudden movements.

EL62757,00001C6 -19-22APR02-1/1

Assembly Instructions

IMPORTANT: When removing joint pins or other load-bearing structures bear in mind the following:

- The lifting capacity of the loader or pulley must be adequate.**
- The hoisting equipment must be reliable and in good working order.**
- The booms must be properly supported in every direction**

EL62757,00001C7 -19-22APR02-1/1

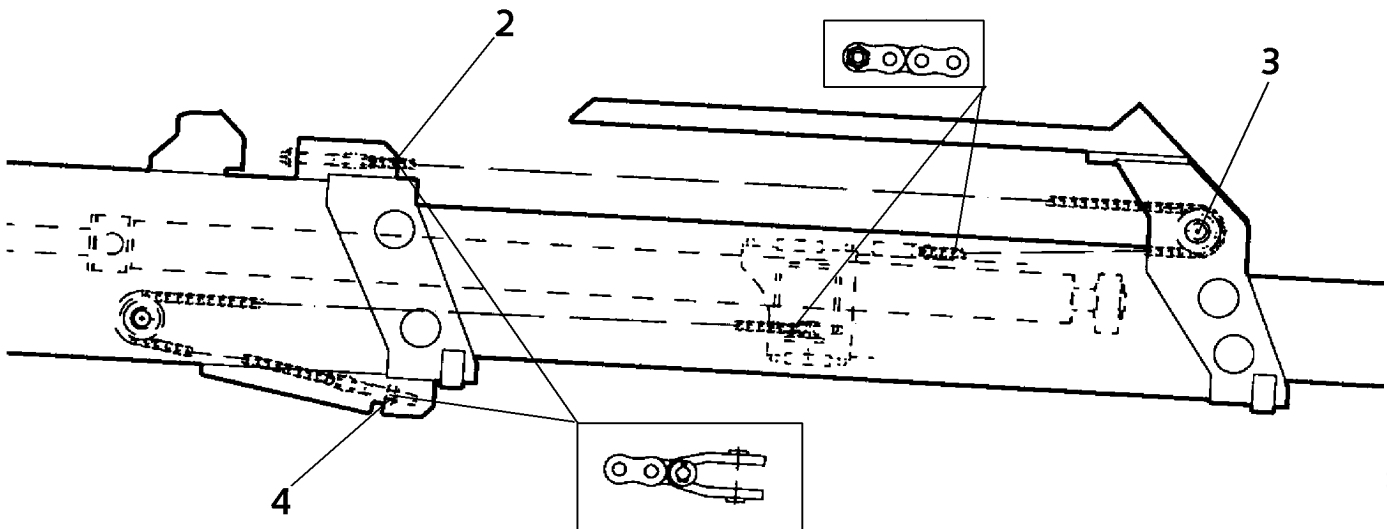

T160064 -UN-02OCT02

Clean the extension boom chains

1. The chains and extensions can be removed by first disconnecting the upper chain from its clamp (2).
2. Next, remove the sheave (3) and bearing housing.
3. Pull the chain through its opening and straighten it on top of the second extension

4. After this, disconnect the lower chain from its clamp (4) and tie a rope to its end.
5. Pull the second extension out.

NOTE: The extension booms and grapple must be properly supported at every stage.

EL62757,00003B4 -19-19MAR03-3/3

Twine magazine

- The twine magazine is mounted on a vertical hydraulically driven turntable
 - equipped with automatic lubrication.
 - consists of 9 storage cylinders for coils of baling twine.
 - The twine coils are tied together and they will be used one after another.
- There is a twine brake and fully adjustable twine stretcher. A proximity switch counts the rotations.

1	motor	80CM + S80cc
1	proximity switch	

- 5—storage cylinders (9 pcs)
 6—Twine brake
 7—Twine stretcher

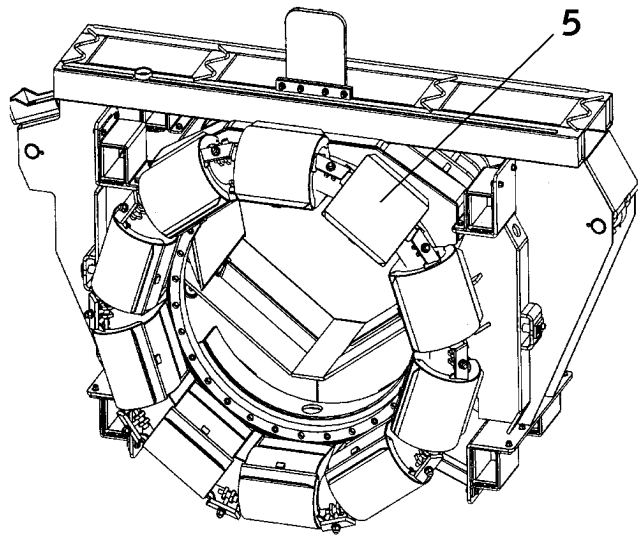

T193878 -JUN-08AUG03

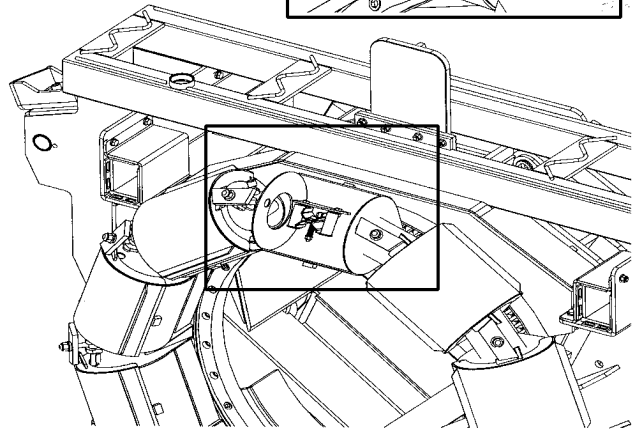
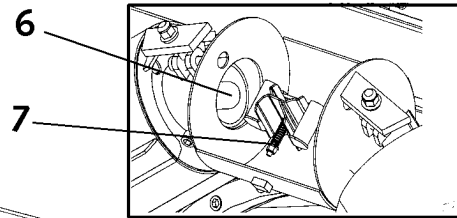

T193879 -JUN-08AUG03

Continued on next page

EL62757,000038F -19-14MAR03-1/2

Filling the Twine Magazine

1. When filling or maintenance the "twine magazine" stop the process so that the compactor III is in its full open position.
2. Rotate the "twine magazine" clockwise by hand so that the "outlet can" is in its upper position.
3. Check that the "beginning" 1. and the "end" 2. is pushing out of the every new twine coil. If it is not so, the "beginning" is bushing throw the roller. See figure A.
4. Open the "outlet can" from the left side and cut the twine. Knot the outlet can's (the left side) and the twine coil's end of twines with the double bond together and put the twine coil into the box. Check that any end or loop is not compressing. Figure B.

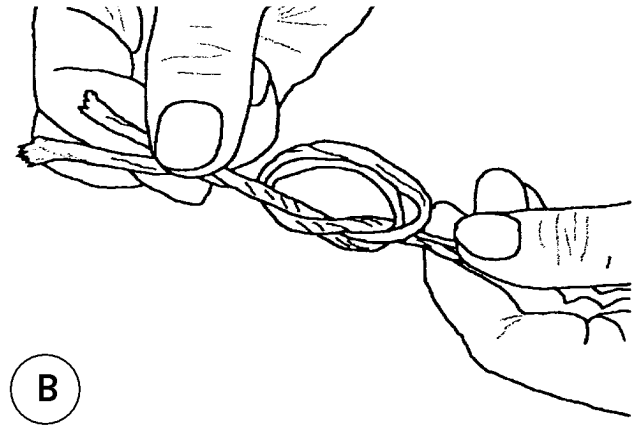
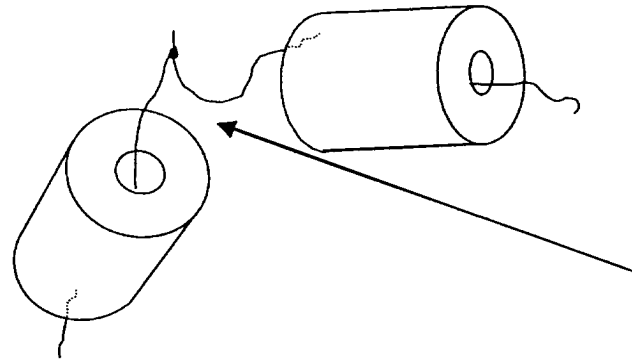
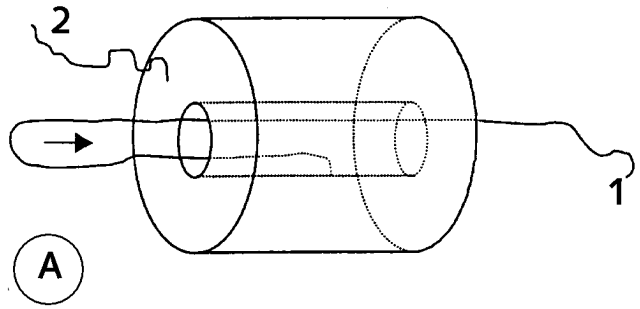

Continued on next page

EL62757,000039A -19-14MAR03-1/2

Equipment, Air Conditioner

Introduction

IMPORTANT: The air conditioner must be serviced and repaired by authorized personnel.

Specifications:

Type and Amount of Refrigerant and the Maximum Pressure Allowed

CAUTION: The air conditioning system has been charged with R-134a refrigerant. Do not use any other type of refrigerant!

The specifications of this air conditioning system are the following:

Refrigerant	Charging volume	High pressure
R134a	1,5 kg 5,5 lbs	8-15 bar 116-217 psi

If the air conditioning system has been modified to use another type of refrigerant, write the new specifications here:

Refrigerant	Charging volume	High pressure
R_____	_____ kg _____ lbs	_____ bar _____ bar

Date of modification: _____

EL62757,00001D8 -19-22APR02-1/1

Main Parts of Air Conditioning System

Compressor

The compressor functions like a pump, drawing in cooled gas under low pressure from the evaporator. After this, the compressor compresses the gas and sends it (in a gaseous state) to the condenser at a high pressure and temperature.

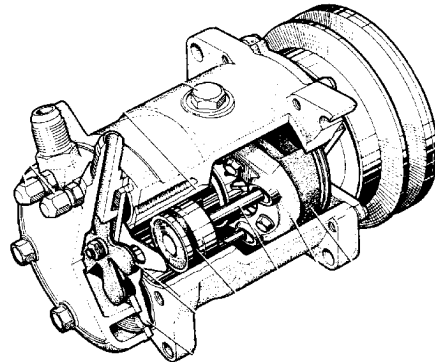

T152366 -JUN-06MAR02

Continued on next page

EL62757,00001D9 -19-22APR02-1/5

Check the service moisture indicator of the dryer every 50 hours

The service indicator should be blue.

The dryer must be replaced, if the indicator area has turned to pink.

NOTE: The filter-dryer-receiver must be replaced always when the hoses are replaced or if the service moisture indicator has turned to pink.

IMPORTANT: Do not operate the system, if the refrigerant charge is insufficient or if there is a leaking in the system, because the compressor will be damaged. Contact your authorized dealer.

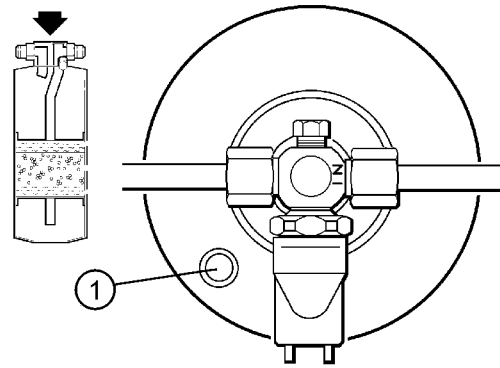

1—Service indicator

T142872 -JUN-13JUN01

EL62757,00001DE -19-22APR02-1/1

Service the compressor V-belt every 250 hours

Make sure that the drive belt tension is correct and that there are no external signs of damage.

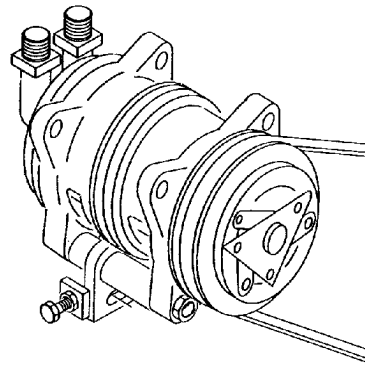

T142874 -JUN-13JUN01

EL62757,00001DF -19-22APR02-1/1

Service the compressor every 1000 hours

Mounting

The compressor must be properly mounted and in alignment, ensuring that the drive belt moves directly on the belt pulley, without wearing the sides of the belt.

Check that the clutch plate and sprocket are clean.

Continued on next page

EL62757,00001E1 -19-22APR02-1/2

Equipment, Engine Preheater

F00	No malfunction
F01	Warning about overvoltage
F02	Warning about undervoltage
F09	TRS 003 unplugging
F10	Overvoltage shutoff
F11	Undervoltage shutoff
F12	Overheating
F13	Possible overheating detected
F14	Too big difference between overheating- and water temperature
*F15	Operation disable because perm.number of possible overheatings exceeded
F20	Glow plug break
F21	Glow plug output overload
F33	Malfunction in combustion engine
F37	Waterpump not working
F42	Water pump short-circuit
F43	Other component short-circuit
F47	Fuel pump short-circuit
F48	Fuel pump break
*F50	Operation disable due to excessive start attempts
F51	Flame signal already at start
F52	Safety time exceeded- no start
F53	Flame cutout from POWER control stage
F54	Flame cutout, HIGH-setting
F55	Flame cutout, Medium-setting
F56	Flame cutout, LOW-setting
F59	Too quick rise in water temperature.
F60	Temperature sensor break
F61	Temperature sensor short-circuit
F64	Flame sensor break
F65	Flame sensor short-circuit
F71	Overheating sensor break
F72	Overheating sensor short-circuit
F90	Control unit defective (internal fault / reset)
F93	Control unit defective (RAM-error)
F94	Control unit defective (EPROM-error)
F97	Internal control unit fault

***) Steps to cancel the disabled operation (fault code F15 or F50)**

Continued on next page

EL62757,00001FF -19-24APR02-8/9

Equipment, Decking Blade

Using the Decking Blade

The decking blade is operated with the push buttons (1 and 2) on the right-hand-side control panel

The decking blade can also be operated with the **right-hand-side boom control lever** .

The lever control is engaged by pushing the push buttons, (1 and 2), simultaneously for 2 seconds. When the lever control is on the decking blade symbol will appear to TMC display.

NOTE: Lever control can only be used when the low gear is on and the boom is off.

When the lever control is engaged the decking blade can be controlled even if nobody was sitting in the seat. lever control is disengaged by switching on the boom or by pressing the decking blade control switches simultaneously.

IMPORTANT: Do not use the decking blade for removing tree stumps or large rocks. During travel, raise the decking blade high enough to clear all obstacles

- 1—Blade up, also with boom control lever-Y
- 2—Blade down, also with boom control lever +Y

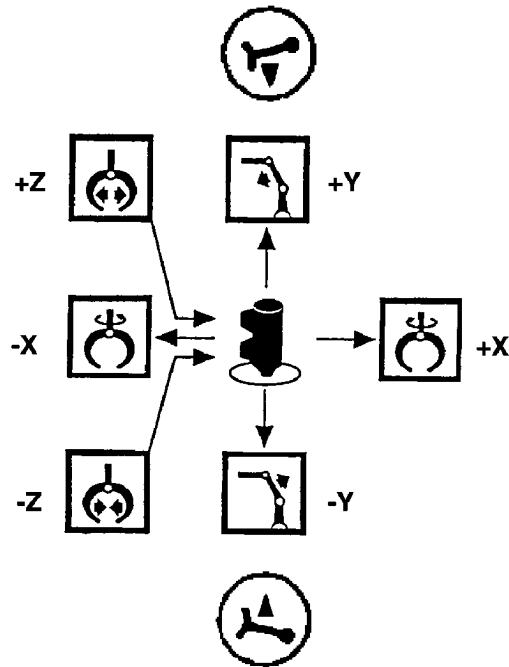
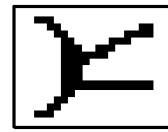
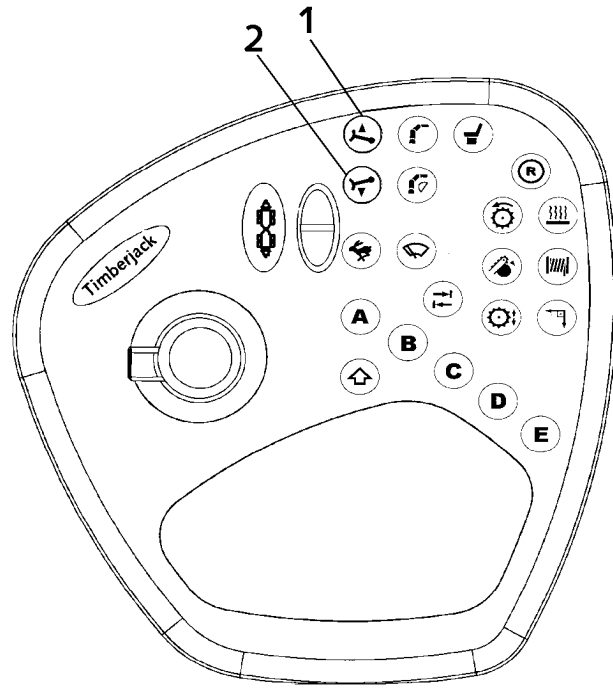

T193939 -UN-12AUG03

EL62757,0000205 -19-24APR02-1/1

Hydraulic Diagrams

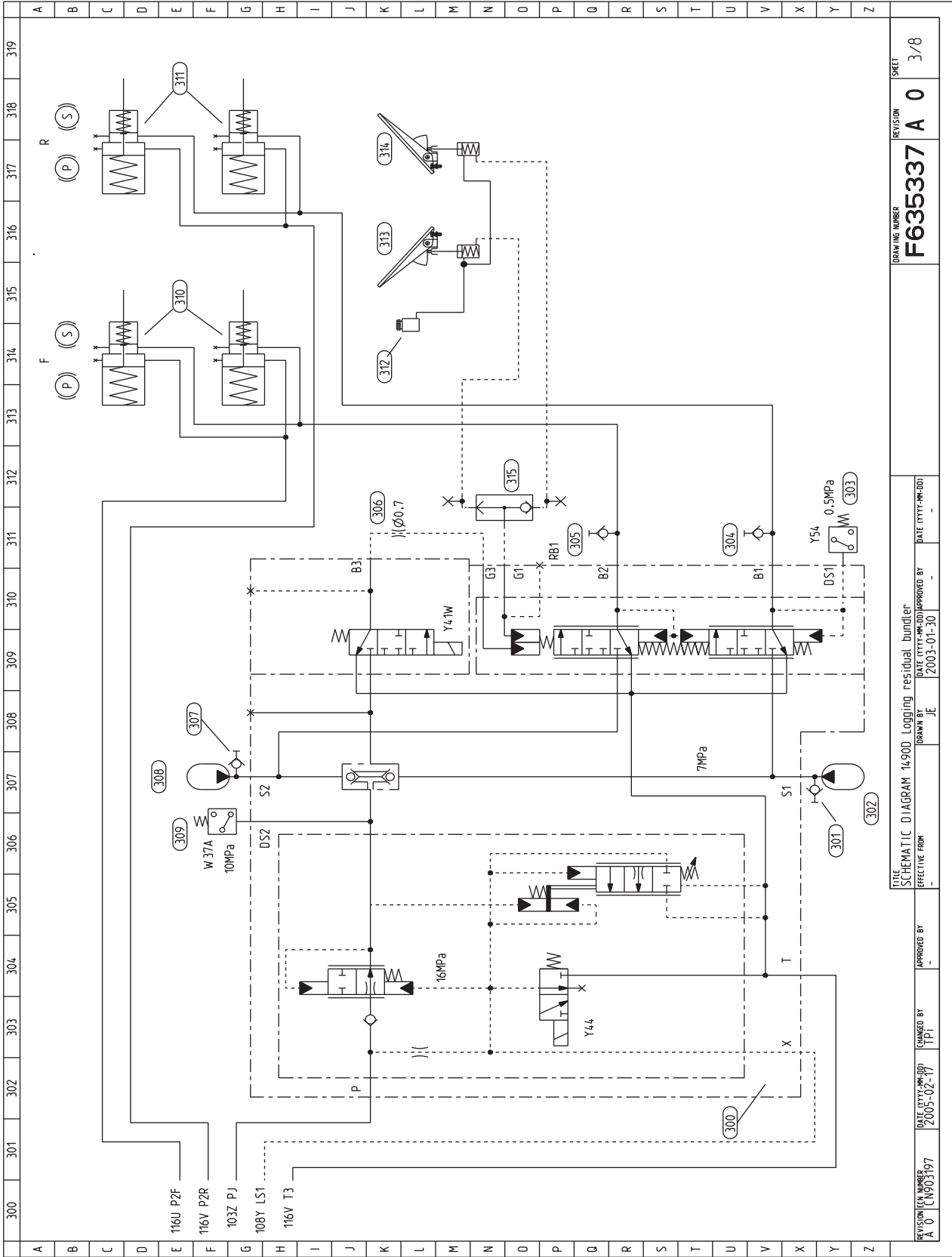

EL62757.00001EA -19-22APR02-2/2

13-1-9

070305
PN=277

T194408 -UN-22APR05

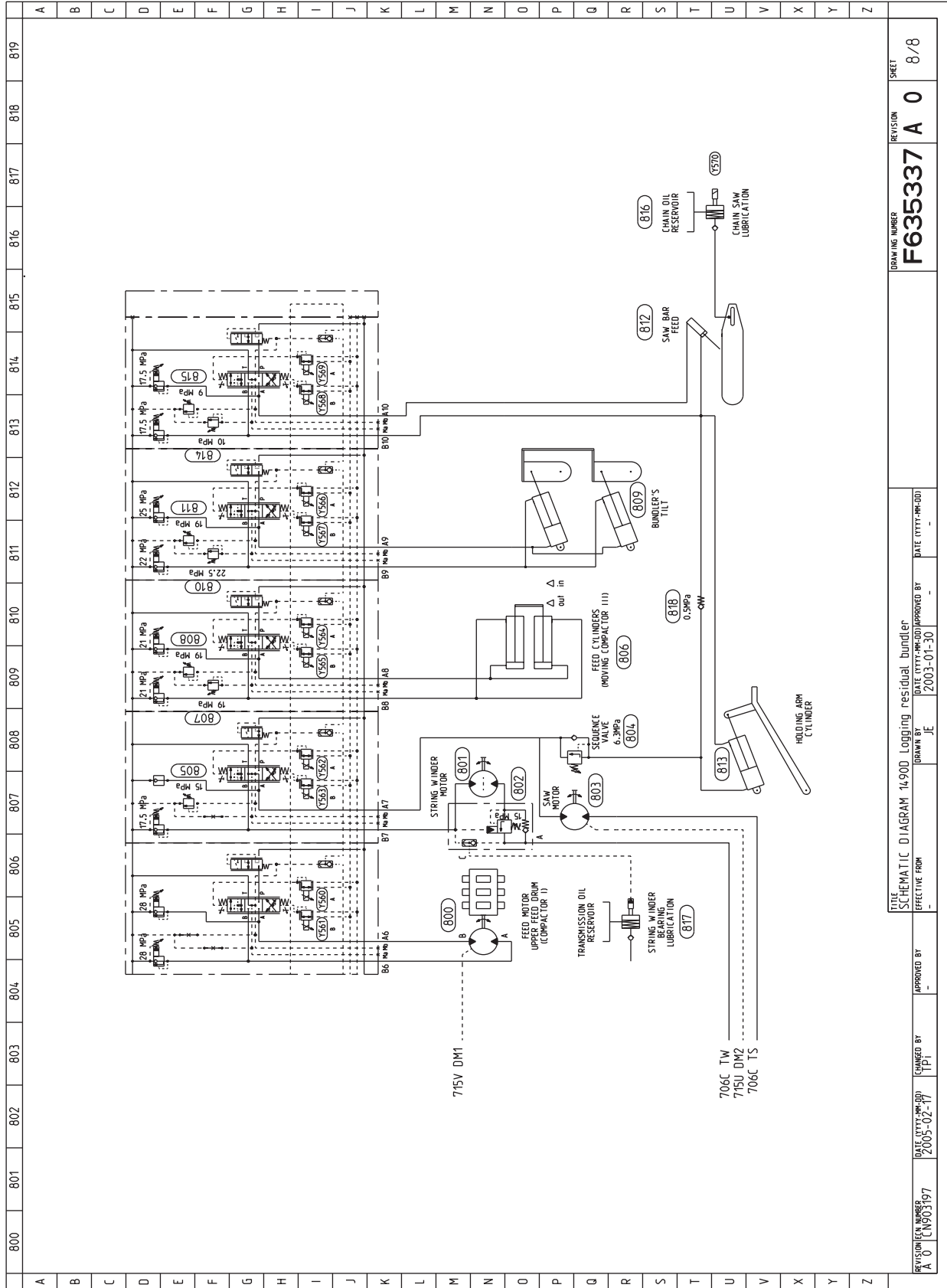

REVISION NUMBER A 0	DATE (YYYY-MM-DD) 2005-02-17	CHANGED BY TPI	APPROVED BY	DRAWN BY JE	DATE (YYYY-MM-DD) 2003-01-30	APPROVED BY	TITLE SCHEMATIC DIAGRAM 14900 Logging residual bundler
DRAWING NUMBER F635337	REVISION A 0	EFFECTIVE FROM		DATE (YYYY-MM-DD)		SHEET 8/8	

EL62757,0000002 -22-04FEB03-2/2

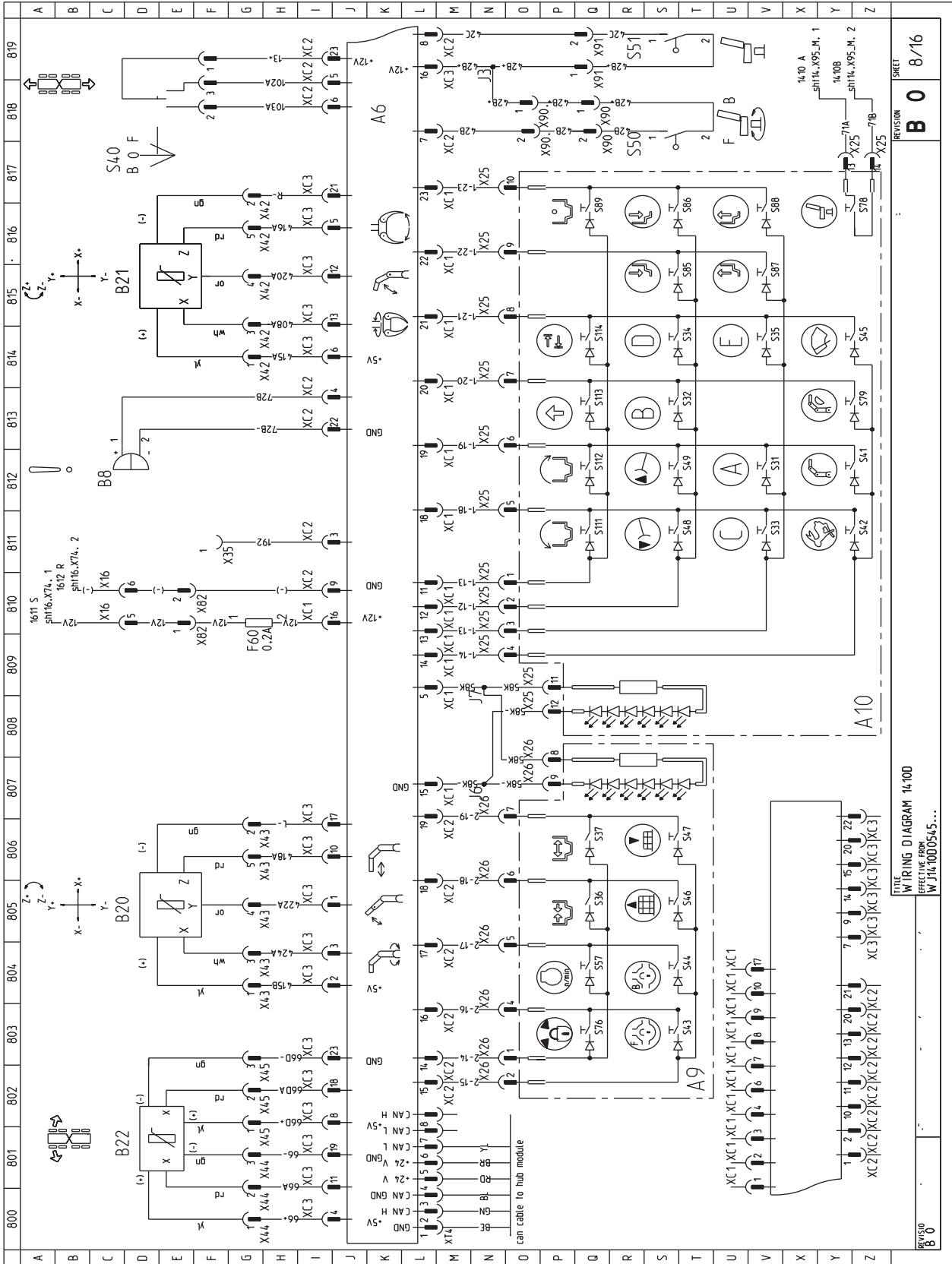

Continued on next page

EL62757.0000482 -67-28OCT04-18/34

13-2-20

070305
PN=307

T202781 -UN-24APR05

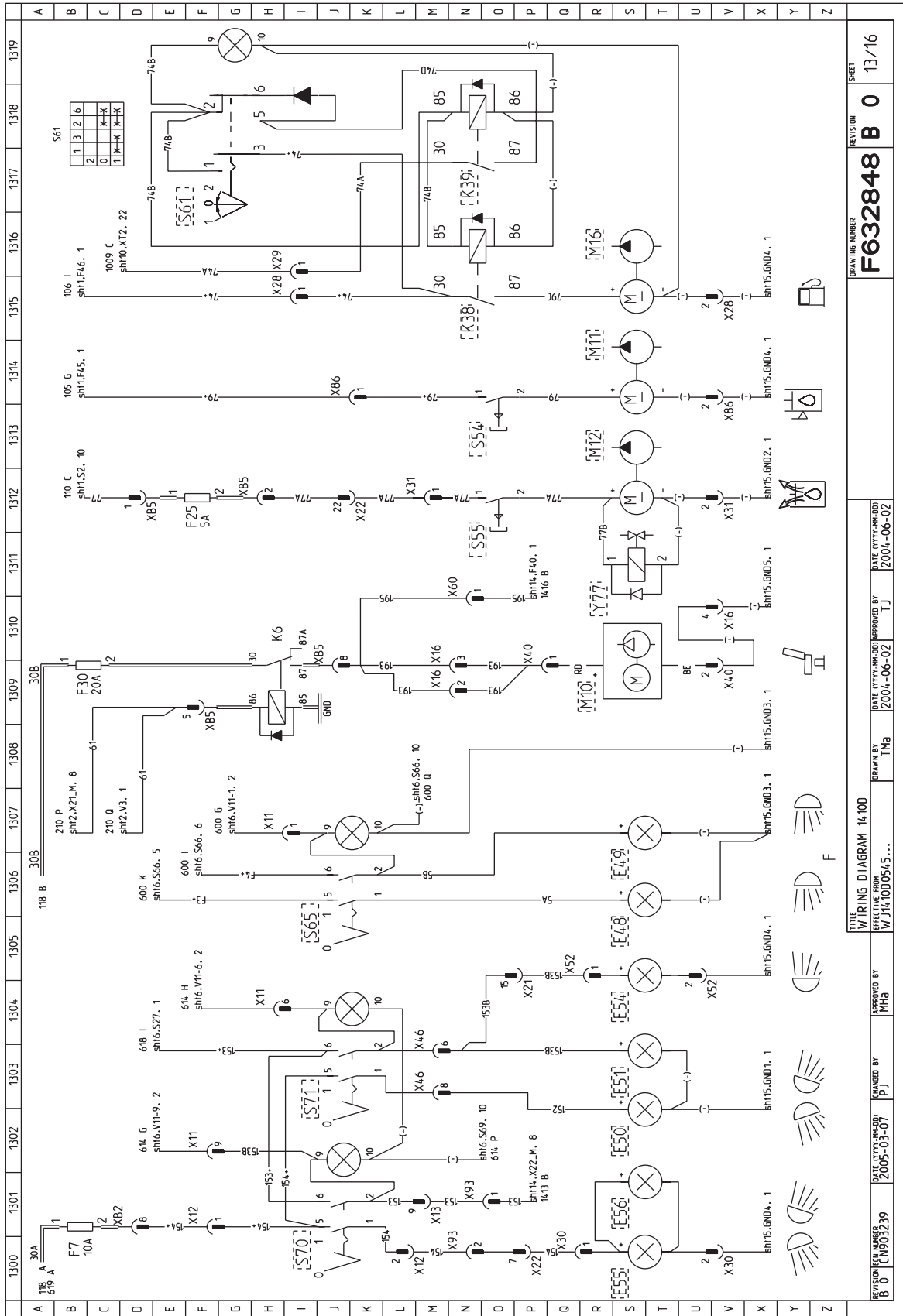

REVISION NUMBER	REVISION	SHEET
B 0	F632848 B 0	13/16
DATE (YYYY-MM-DD)	DATE (YYYY-MM-DD)	DATE (YYYY-MM-DD)
2005-03-07	2004-06-02	2004-06-02
DESIGNED BY	DRAWN BY	TITLE
PNJ	TMB	WIRING DIAGRAM 14-100
CHANGED BY	APPROVED BY	EFFECTIVE FROM
	MPB	W 714-1000545...

Continued on next page

EL62757.0000482 -67-28OCT04-28/34

Electric Diagrams

Position	Description	Scheme	Location
X16	6-pin connector	110 C	Instrument box
X25	14-pin connector	110 N	Control panel, R
X26	9-pin connector	107 O	Control panel, L
X35	-pin connector	111 G	
X42	9-pin connector	114 H	Control panel, R
X43	9-pin connector	103 H	Control panel, L
X44	3-pin connector	100 H	Control panel, L
X45	3-pin connector	102 H	Control panel, L
X82	2-pin connector	110 F	Seat
X90	2-pin connector	118 O	Seat
X91	2-pin connector	119 Q	Seat
XC1-XC3	23-pin connector	110 I	Chair module
XT4	8-pin connector	100 M	Chair module

Continued on next page

EL62757,00004E4 -19-08APR04-4/11

Engine

John Deere, 6068HTJ77 water-cooled and turbocharged 6-cylinder diesel engine with intercooler.

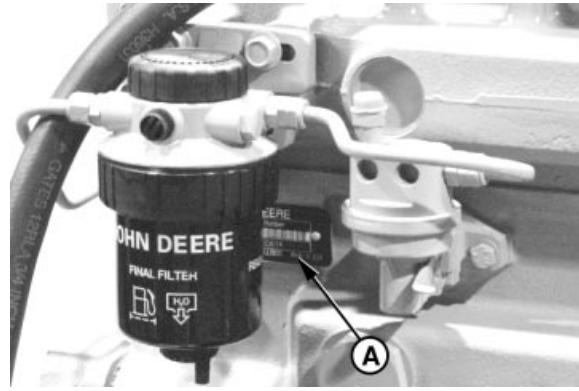

RG7778 -UN-11NOV97

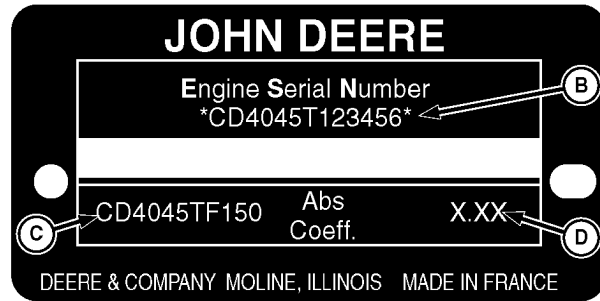

RG9061 -UN-16MAR98

Saran Engine Serial Number Plate

- A—Serial Number Plate
- B—Engine Serial Number
- C—Engine Application Data
- D—Coefficient of Absorption (Saran Engines Only)

Item	Measurement	Specification
Engine John Deere JD6068 HTJ77	Max. output Torsional moment Fuel tank	136kW (182 hp)/ 1900 r/min 779 Nm (574,6 lbt-ft)/ 1400 r/min 165 l (43,6 US gal)

EL62757,0000003 -19-06FEB02-1/1

Axles

- Patented, balanced gear-driven bogie, portal type
- Identical axles front and rear.
- Mechanical differential lock front and rear.
- Release of rear-wheel drive.

EL62757,0000005 -19-06FEB02-1/1

CLICK HERE TO **DOWNLOAD** THE COMPLETE MANUAL

- Thank you very much for reading the preview of the manual.
- You can download the complete manual from: www.heydownloads.com by clicking the link below



- Please note: If there is no response to CLICKING the link, please download this PDF first and then click on it.

CLICK HERE TO **DOWNLOAD** THE COMPLETE MANUAL