

Foreword	0-1	5. TRANSPORTATION	
Before servicing this machine	0-2	1. Road traveling	5-1
Table to enter S/No and distribution	0-3	2. Preparation for transportation	5-2
Safety labels	0-4	3. Loading the machine	5-3
Guide (direction, S/No, symbol)	0-10	4. Fixing the machine	5-4
		5. Loading and unloading by crane	5-6
		6. Towing the machine	5-7
1. SAFETY HINTS		6. MAINTENANCE	
1. Before operating the machine	1-1	1. Instruction	6-1
2. During operating the machine	1-5	2. Tightening torque	6-5
3. During maintenance	1-14	3. Specification of fuel, coolant and lubricants	6-8
4. Parking	1-18	4. Maintenance check list	6-10
2. SPECIFICATIONS		5. Maintenance chart	6-13
1. Major components	2-1	6. Service instruction	6-15
2. Specifications	2-2	7. Electrical system	6-41
3. Specification for major components	2-4	8. Air conditioner and heater	6-44
3. CONTROL DEVICES		7. TROUBLESHOOTING GUIDE	
1. Cab devices	3-1	1. Engine	7-1
2. Cluster	3-2	2. Electrical system	7-2
3. Switches	3-6	3. Power train system	7-3
4. Control device	3-9	4. Others	7-4
5. Air conditioner and heater	3-12	INDEX	8-1
6. Radio and MP3 player	3-15		
7. Others	3-21		
4. OPERATION			
1. Suggestion for new machine	4-1		
2. Check before starting the engine	4-2		
3. Starting and stop the engine	4-3		
4. Warming-up operation	4-5		
5. Operation of the working device	4-6		
6. Traveling of the machine	4-7		
7. Efficient working method	4-12		
8. Operation in the special work sites	4-19		
9. Storage	4-21		

CLICK HERE TO **DOWNLOAD** THE COMPLETE MANUAL

- Thank you very much for reading the preview of the manual.
- You can download the complete manual from: www.heydownloads.com by clicking the link below



- Please note: If there is no response to CLICKING the link, please download this PDF first and then click on it.

CLICK HERE TO **DOWNLOAD** THE COMPLETE MANUAL

GUIDE

1. DIRECTION

The direction of this manual indicate forward, backward, right and left, when machine is on the traveling direction.

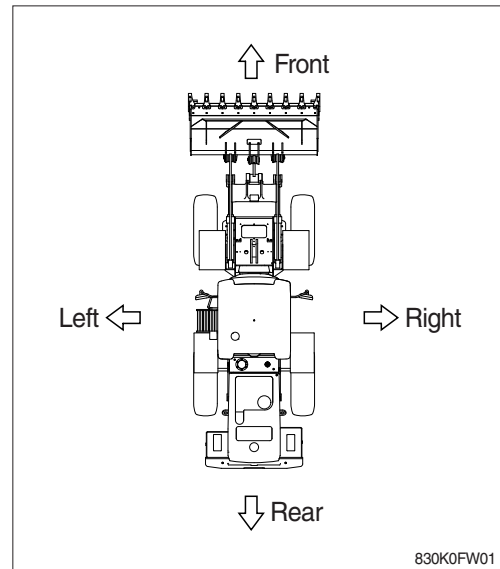

2. SERIAL NUMBER

Inform following when you order parts or the machine is out of order.

1) MACHINE SERIAL NUMBER

The numbers are located on the left side of the rear frame.

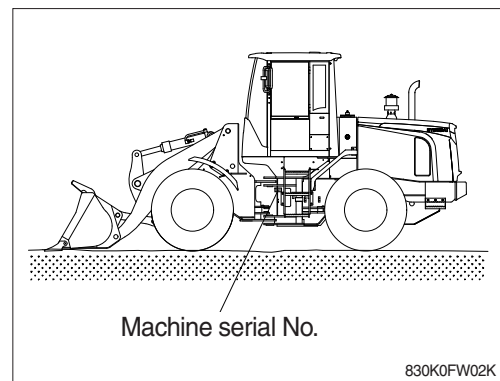

2) ENGINE SERIAL NUMBER

The numbers are located on the engine name plate.

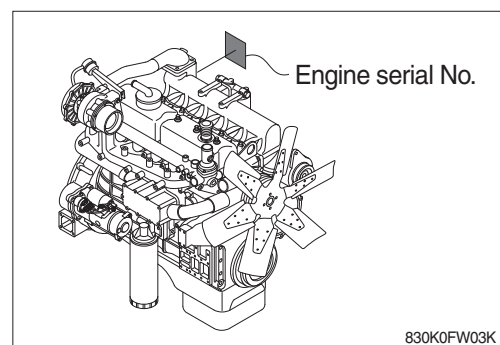

4. SYMBOLS

▲ Important safety hint.

△ It indicates matters which can cause the great loss on the machine or the surroundings.

※ It indicates the useful information for operator.

This machine is intended to be used only for excavation and loading. Do not use this for pulling up materials. Unlike a crane, this machine is not equipped with devices needed to pull up things.

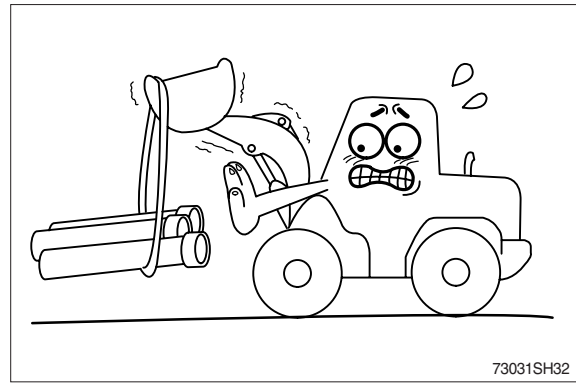

Slow down when traveling through obstacles or uneven ground.

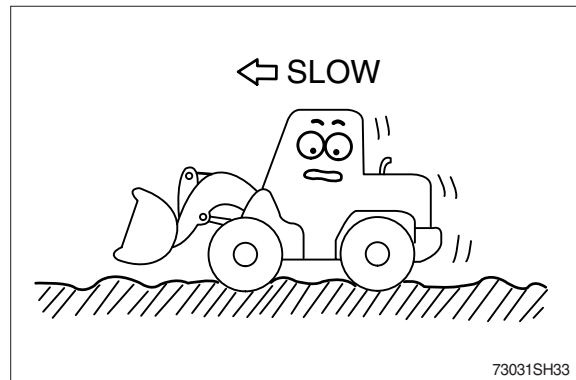

When operating in water or when crossing shallows, check the bed soil condition and depth and flow speed of water, then proceed taking care that water is not above axle housing.

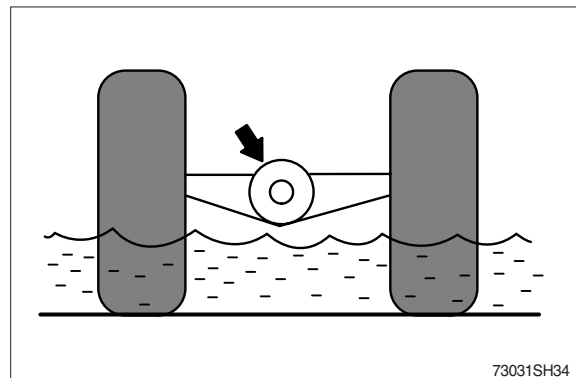

Never allow anyone near the center articulation pivot.
If the machine turned, they could be crushed.



2. SPECIFICATIONS

1) WITH BOLT-ON CUTTING EDGE TYPE BUCKET

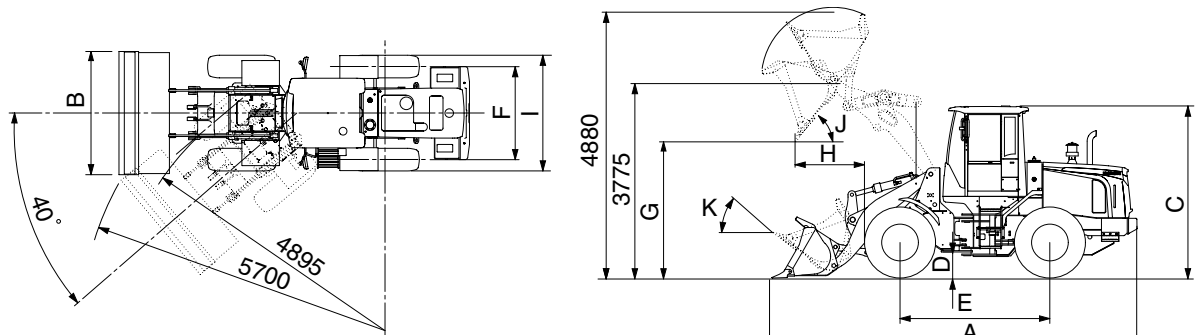

830K2SE03E

Description		Unit	Specification	
Operating weight		kg (lb)	10200 (22490)	
Bucket capacity	Struck	m ³ (yd ³)	1.5 (2.0)	
	Heaped		1.8 (2.4)	
Overall length	A	mm (ft-in)	6830 (22' 5")	
Overall width	B		2450 (8' 1")	
Overall height	C		3235 (10' 7")	
Ground clearance	D		370 (1' 3")	
Wheelbase	E		2850 (9' 4")	
Tread	F		1850 (6' 1")	
Dump clearance at 45°	G		2865 (9' 5")	
Dump reach (full lift)	H		1075 (3' 6")	
Width over tires	I		2300 (7' 7")	
Dump angle	J		degree (°)	45
Roll back angle (carry position)	K			49
Cycle time	Lift (with load)	sec	5.2	
	Dump (with load)		1.2	
	Lower (empty)		2.7	
Maximum travel speed		km/hr (mph)	39.5 (24.5)	
Braking distance		m (ft-in)	13.1 (43' 0")	
Minimum turning radius (center of outside tire)			4.90 (16' 1")	
Gradeability		degree (°)	30	
Travel speed	Forward	First gear	7.4 (4.6)	
		Second gear	13.3 (8.3)	
		Third gear	23.9 (14.9)	
		Fourth gear	39.5 (24.5)	
	Reverse	First gear	9.2 (5.7)	
		Second gear	29.0 (18.0)	

2) HAZARD SWITCH

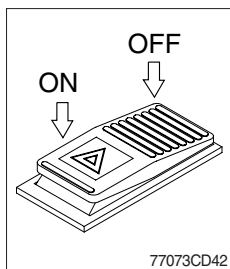

- (1) Use for parking, or roading machine.
- (2) Both turn signal lights will flash simultaneously.

※ If the switch is left ON for a long time, the battery may be discharged.

3) WORK LAMP SWITCH

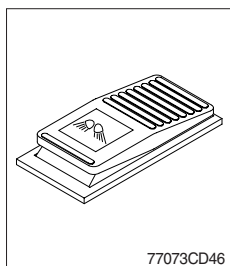

- (1) This switch use to operate the front and rear work lamps by two step.
 - First step : Front work lamp located on the cab comes ON.
 - Second step : Rear work lamp located on the cowl comes ON.

4) FRONT WIPER AND WASHER SWITCH

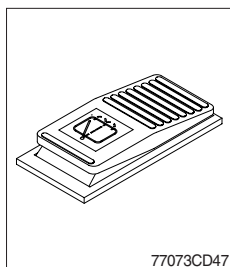

- (1) The switch use to operate the front wiper and washer by two step.
 - First step : The front wiper operates.
 - Second step : The washer liquid is sprayed and the front wiper is operated only while pressing. If release the switch, return to the first step position.

5) BEACON SWITCH (option)

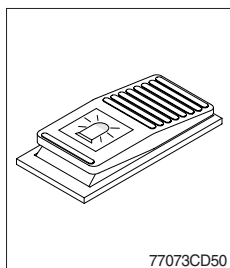

- (1) This switch turns ON the rotary light on the cab.

6) HORN BUTTON

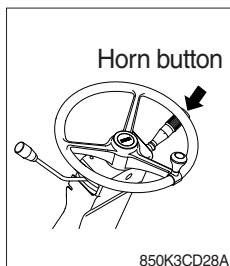

- (1) If you press the button on the top of the multifunction switch, the horn will sound.

4) OPERATION EXPLAINING

(1) Explaining of the button mode function of the radio

- ① M1, M2, M3, M4, M5, M6 button is used in FM1, FM2, FM3, AM1, AM2 every waves of frequency, pre-store data.
 - Pressing button TIME<2 seconds, release the button and shift the corresponding tune to listen.
 - Pressing button TIME>2 seconds, store the frequency value of radio station that listens to at present in the present corresponding memory.
- ② It uses BND to shift the FM1, FM2, FM3, AM1, AM2, over radio reception band.
 - Pressing button TIME<2 seconds, form the wave band and switch over the function, shifted in different wave band FM1 → FM2 → FM3 → AM1 → AM2 → FM1 Between switch over.
 - Pressing TIME>2 seconds, form the function of the wave band scans and stores (AUT function).

Description of the function of wave band scans and stores (AUT function)

In FM frequency band before scanning, the clear short range marks (LOC), namely long-range search; From wave band CH1 of FM1, the frequency of 87.5M begins to scan upwards and store the platform searched out automatically, have acted as and finished storing the memory of FM1- FM3 wave band (CH1- CH6, amounts to 18 radio stations); Or after scanning one circle from 87.5M- 108M, turn into wave band CH1 of FM1 to listen to. If there are radio stations, what the platform received newly will be covered originally and radio station of number on the same stage of wave band in the original memory. For instance: In fact FM2, CH2 have radio station 91.8M, it is FM2 to scan the wave band at present, CH1, after receiving new effective radio station 93M, will keep for FM2, CH2, will cover original 91.8M at this moment.

In AM wave band before scanning. From frequency band CH1 of AM1, the frequency of 531K/530K begins to scan upwards and store the platform searched out automatically, acts as and finishes storing the memory of AM1- AM2 wave band (CH1- CH6, amounts to 12 radio stations); Or after scanning one circle from 531K- 1602K/530K- 1620K, turn into wave band CH1 of AM1 to listen to. If there are radio stations, what the platform received newly will be covered originally and radio station of number on the same stage of wave band in the original memory.

While storing automatically, a number will show according to the number stored.

When the system is at the wave band scans and stores the function, press BAND, POWER, M1, M2, M3, M4, M5, M6, withdraw from this function.

- ③ **Revolve the encoder** (The grade of the button panel is ⑨)
 - TUNE + frequency which is used in the radio are manually tuning, rotate a step of moving long right or left.
- ④ **Auto tuning** (The grade of the button panel is ⑧ two sides keys)
 - TU + /TU - is used for searching from present frequency upwards or downwards, if search out a platform and stop listening to in present frequency, otherwise continue searching for frequency.

CLICK HERE TO **DOWNLOAD** THE COMPLETE MANUAL

- Thank you very much for reading the preview of the manual.
- You can download the complete manual from: www.heydownloads.com by clicking the link below



- Please note: If there is no response to CLICKING the link, please download this PDF first and then click on it.

CLICK HERE TO **DOWNLOAD** THE COMPLETE MANUAL

3) INSPECTION AFTER ENGINE START

Inspect and confirm the following after engine starts.

- (1) Is the sight gauge of hydraulic oil tank in the normal level?
 - (2) Are there leakages of oil or water?
 - (3) Are all the warning lamps (1-4) OFF?
 - (4) Check the following after warming up operation.
 - ① Is the indicator of water temperature gauge (5) in the operating range?
 - ② Is the indicator of transmission oil temperature gauge (6) in the operating range?
 - ③ Is the engine sound and the color of exhaust gas normal?
 - ④ Are the sound and vibration normal?
- ※ **Do not increase engine speed quickly after starting, it can make damage engine or turbocharger.**
 - ※ **If there are problems in the control panel, stop the engine immediately and correct problem as required.**

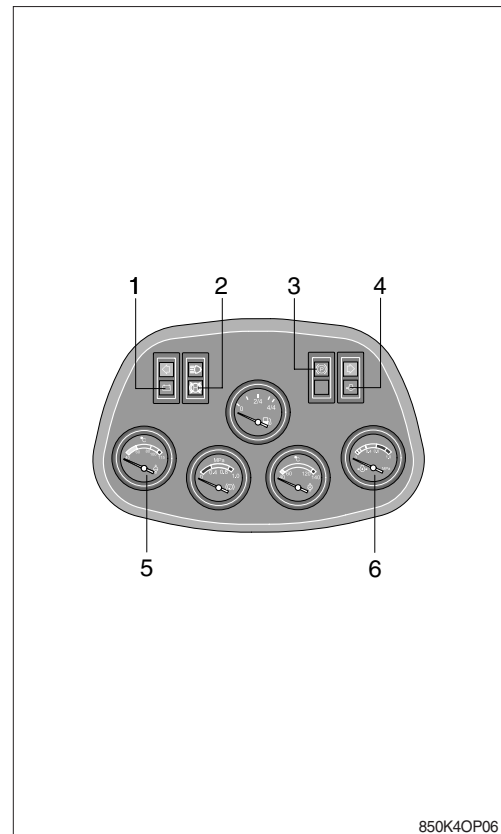

4) TO STOP THE ENGINE

- ※ **If the engine is abruptly stopped before it has cooled down, engine life may be greatly shortened. Consequently, do not abruptly stop the engine apart from an emergency.**
- ※ **In particularly if the engine has overheated, do not abruptly stop it but run it at medium speed to allow it to cool gradually, then stop it.**

- (1) Place the gear selector lever in neutral.
- (2) Pull the parking brake lever up to engage the parking brake.
- (3) Put the safety lock lever in the LOCK position.
- (4) Run the engine for five minutes at low idle with no load.
- (5) Return the key of starting switch to the OFF position.
- (6) Remove the key to prevent other people using the machine.
- (7) Lock the cab door.

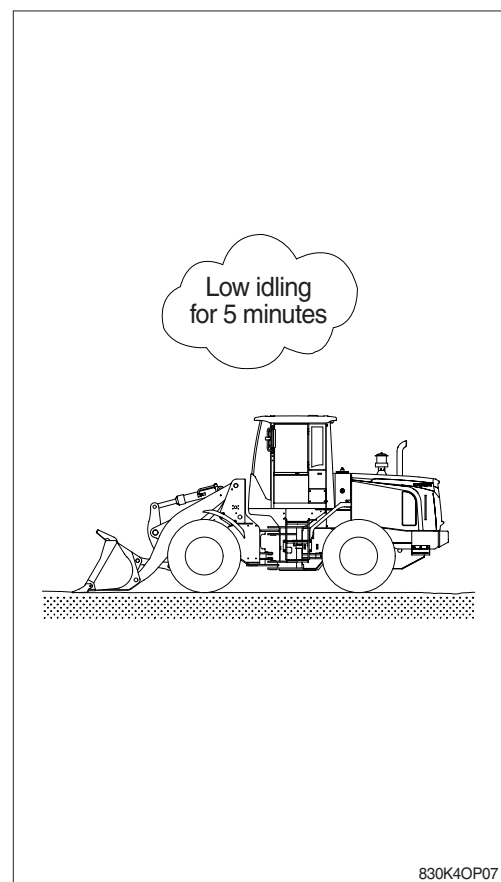

(2) Excavation on level ground

Advance the machine with the bucket lowered slightly and make sure that the bucket is evenly loaded on both sides.

- ① Lower the bucket edge slightly.

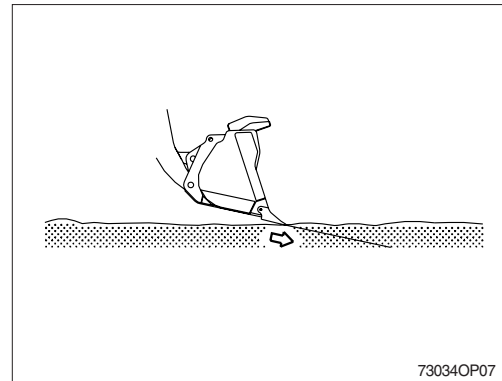

- ② Advance the machine and lift the bucket using the bucket control lever to dig out the soil.

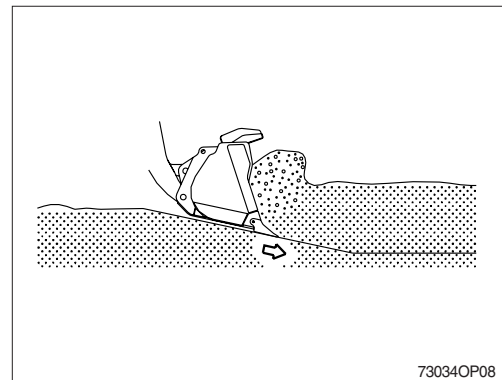

- ③ Advance the machine while controlling the depth of digging with the control lever.
 - ※ Do not press the bucket heavily into the ground. It may damage its driving force.
 - ※ Use the bucket suitable to the working condition.
 - ※ When excavating, prevent the excavation force from applying only one side of the bucket.

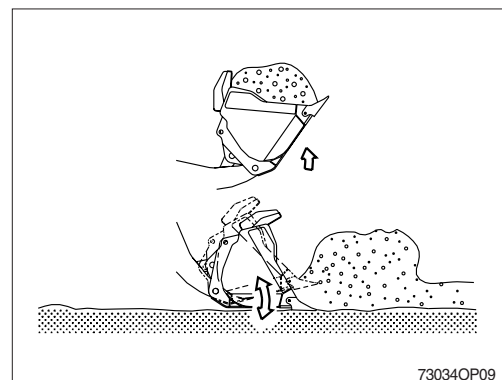

2. PREPARATION FOR TRANSPORTATION

- 1) When transporting the machine, observe the various road rules, road transportation vehicle laws and vehicle limit ordinances, etc.
- 2) Make sure the cooling system has proper anti-freeze if moving machine to a cold climate.
- 3) Select proper trailer after confirming the weight and dimension from the page 2-2, 2-3.
- 4) Check the whole route such as the road width, the height of bridge and limit of weight and etc., which will be passed.
- 5) Get the permission from the related authority if necessary.

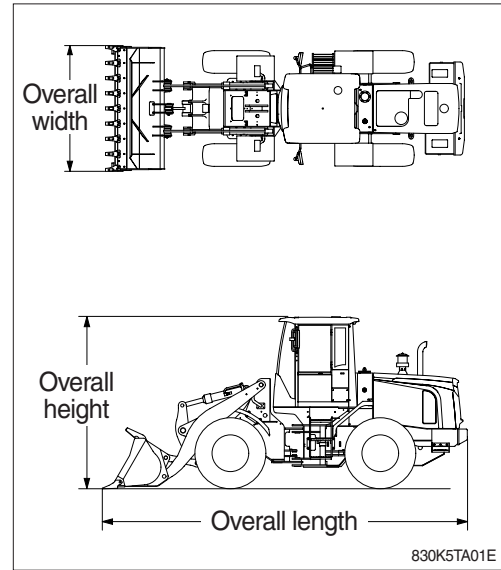

- 6) Prepare gangplank for safe loading referring to the below table and illustration.

A	B
1.0	3.65 ~ 3.85
1.1	4.00 ~ 4.25
1.2	4.35 ~ 4.60
1.3	4.75 ~ 5.00
1.4	5.10 ~ 5.40
1.5	5.50 ~ 5.75

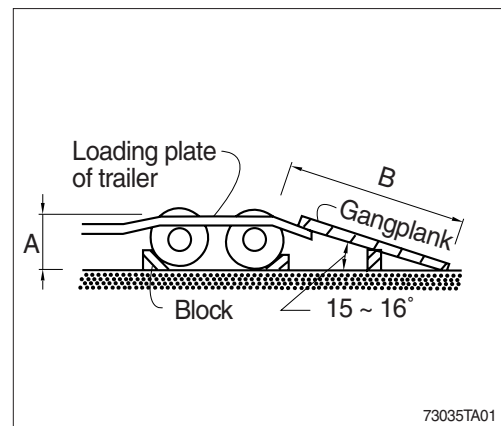

4) PRECAUTION WHEN INSTALLING HYDRAULIC HOSES OR PIPES

- (1) Be particularly careful that the joint of hose, pipe and functioning item are not damaged.
Avoid contamination.
- (2) Assemble after cleaning the hose, pipe and joint of functioning item.
- (3) Use genuine parts.
- (4) Do not assemble the hose in the condition of twisted or sharp radius.
- (5) Keep the specified tighten torque.

5. MAINTENANCE CHART

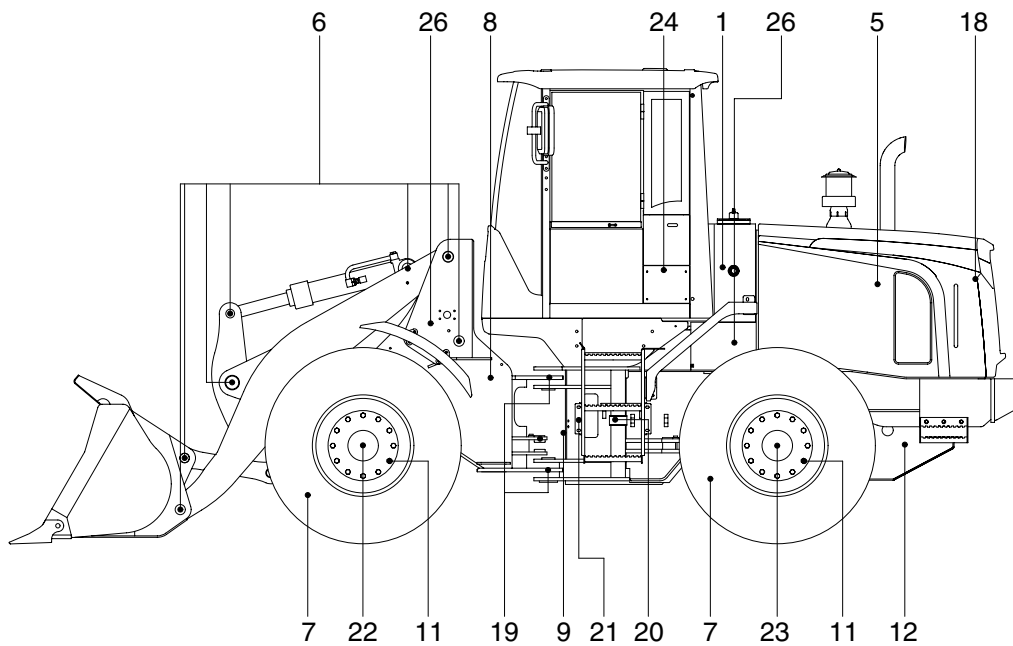
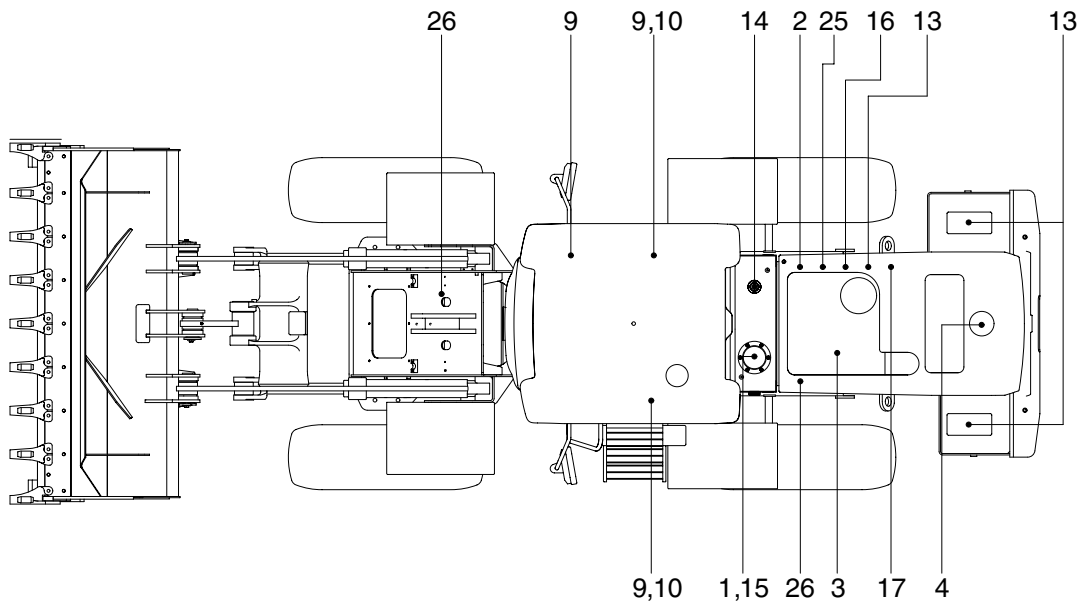

830K6M123E

Caution

1. Service intervals are based on the hour meter reading.
2. The number of each item shows the lubrication point on the machine.
3. Stop engine while filling oil, and use no open flames.
4. For other details, refer to the service manual.

9) REPLACEMENT OF FUEL FILTER

(1) Remove the fuel filter.

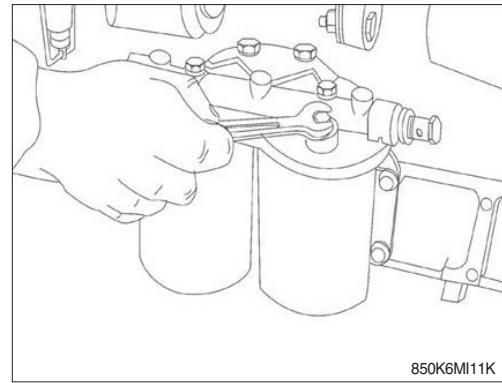

(2) Fill the fuel filter with clean fuel, and lubricate the filter sealing surface with clean lubricating oil.

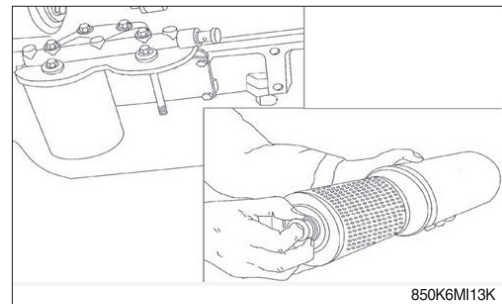

(3) Install the filter to the filter head.

- ※ **Mechanical over tightening can distort the threads or damage the filter element seal.**
- ※ **Check for fuel leakage after the engine starts.**

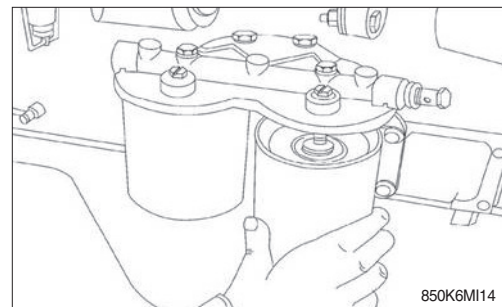

10) PREFILTER

(1) Drain the water and sediment by loosening the drain valve.

(2) Drain the filter sump until clean fuel is visible.

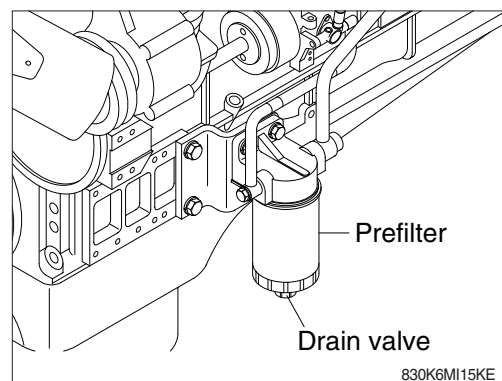

25) CLEANING TRANSMISSION AIR BREATHER

- (1) Remove dust or debris around the air breather.
- (2) Remove the air breather and wash it with cleaning oil.

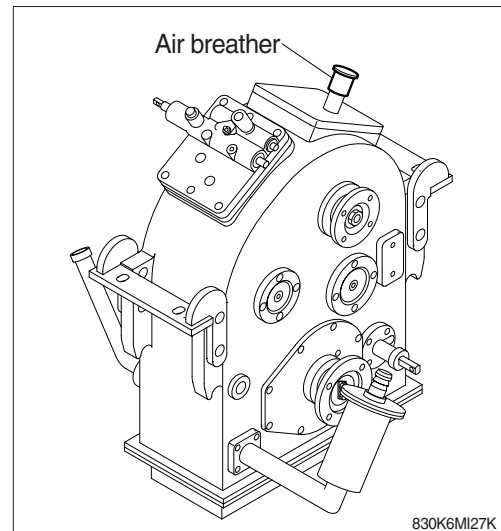

26) CHECK AND SUPPLYING AXLE OIL

- (1) Move the machine to flat ground.
- (2) Open the axle air breather to relieve internal air pressure.

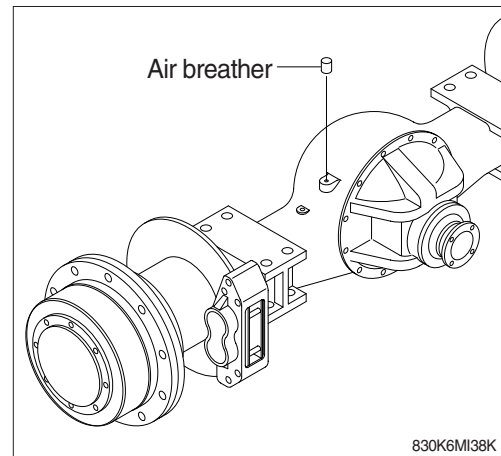

- (3) Remove the plug and check the oil amount.
If the oil level is at the hole of the plug, it is normal.

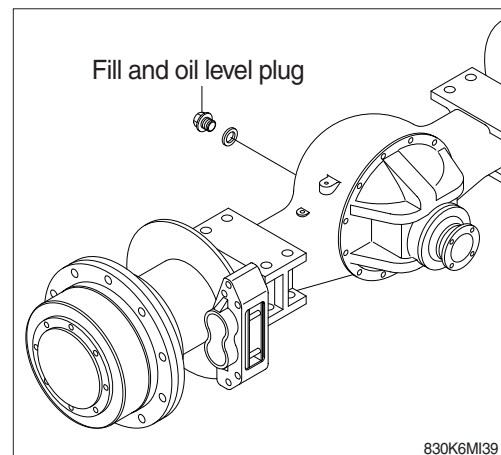

CLICK HERE TO **DOWNLOAD** THE COMPLETE MANUAL

- Thank you very much for reading the preview of the manual.
- You can download the complete manual from: www.heydownloads.com by clicking the link below



- Please note: If there is no response to CLICKING the link, please download this PDF first and then click on it.

CLICK HERE TO **DOWNLOAD** THE COMPLETE MANUAL