

CONTENTS

Foreword	0-1	6. Traveling of the machine	4-13	
Before servicing this machine	0-2	7. Efficient working method	4-16	
Table to enter S/No and distribution	0-3	8. Operation in the special work sites	4-20	
Safety labels	0-4	9. Normal operation of excavator	4-22	
Machine data plate	0-16	10. Attachment lowering	4-23	
Guide (direction, S/No, symbol)	0-17	11. Storage	4-24	
SAFETY HINTS		12. RCV lever operating pattern	4-26	
1. Before operating the machine	1-1	13. Switching hydraulic attachment circuit	4-27	
2. During operating the machine	1-6	TRANSPORTATION		
3. During maintenance	1-13	1. Preparation for transportation	5-1	
4. Parking	1-16	2. Dimension and weight	5-2	
SPECIFICATIONS		3. Loading the machine	5-6	
1. Major components	2-1	4. Fixing the machine	5-8	
2. Specifications	2-2	5. Loading and unloading by crane	5-9	
3. Working range	2-5	MAINTENANCE		
4. Weight	2-8	1. Instruction	6-1	
5. Lifting capacities	2-11	2. Tightening torque	6-6	
6. Bucket selection guide	2-14	3. Fuel, coolant and lubricants	6-9	
7. Undercarriage	2-16	4. Maintenance check list	6-11	
8. Specification for major components	2-18	5. Maintenance chart	6-16	
9. Recommended oils	2-22	6. Service instruction	6-18	
CONTROL DEVICES		7. Electrical system	6-41	
1. Cab devices	3-1	8. Air conditioner and heater	6-44	
2. Cluster	3-2	TROUBLESHOOTING GUIDE		
3. Switches	3-23	1. Engine	7-1	
4. Levers and pedals	3-28	2. Electrical system	7-2	
5. Air conditioner and heater	3-30	3. Others	7-3	
6. Others	3-37	HYDRAULIC BREAKER AND QUICK CLAMP		
OPERATION		1. Selecting hydraulic breaker	8-1	
1. Suggestion for new machine	4-1	2. Circuit configuration	8-2	
2. Check before starting the engine	4-2	3. Maintenance	8-3	
3. Starting and stop the engine	4-3	4. Precaution while operating the breaker	8-4	
4. Mode selection system	4-7	5. Quick clamp	8-6	
5. Operation of the working device	4-12	INDEX		9-1

CLICK HERE TO **DOWNLOAD** THE COMPLETE MANUAL

- Thank you very much for reading the preview of the manual.
- You can download the complete manual from: www.heydownloads.com by clicking the link below



- Please note: If there is no response to CLICKING the link, please download this PDF first and then click on it.

CLICK HERE TO **DOWNLOAD** THE COMPLETE MANUAL

17) REF OPERATOR'S MANUAL

(1) Ref operator manual

- ▲ Study the operator's manual before starting and operating machine.

(2) Max height

- ▲ Serious injury or death can result from contact with electric lines.

An electric shock being received by merely coming into the vicinity of an electric lines, the minimum distance should be kept considering the supply voltage as page 1-7.

(3) Interference

- ▲ Be careful to operate machine equipped with quick clamp or extensions. Bucket may hit cab or boom, boom cylinders when it reached vicinity of them.

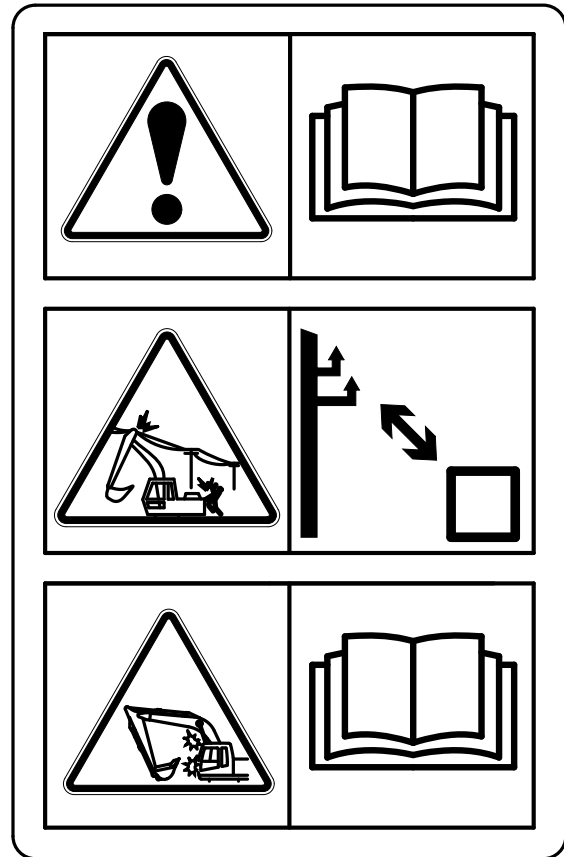

18) SAFETY FRONT WINDOW

- ▲ Be careful that the front window may be promptly closed.

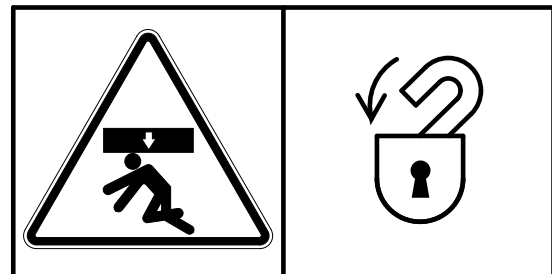

SAFETY REAR WINDOW

The rear window serves us an alternate exit.

To remove rear window, pull the ring and push out the glass.

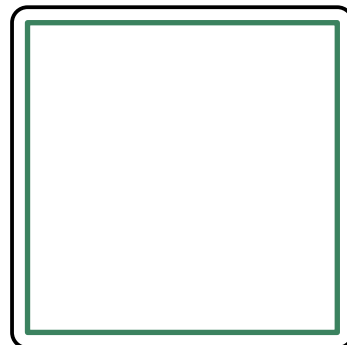

PROTECTION AGAINST FALLING OR FLYING OBJECTS

If there is any danger of falling or flying objects hitting the operator, install protective guards in place to protect the operator as required for each particular situation.

Be sure to close the front window before commencing work.

Make sure to keep all persons other than operator outside the range of falling or flying objects. In case you need top guard, front guard and FOPS (falling object protective structure), please contact Hyundai distributor in Europe.

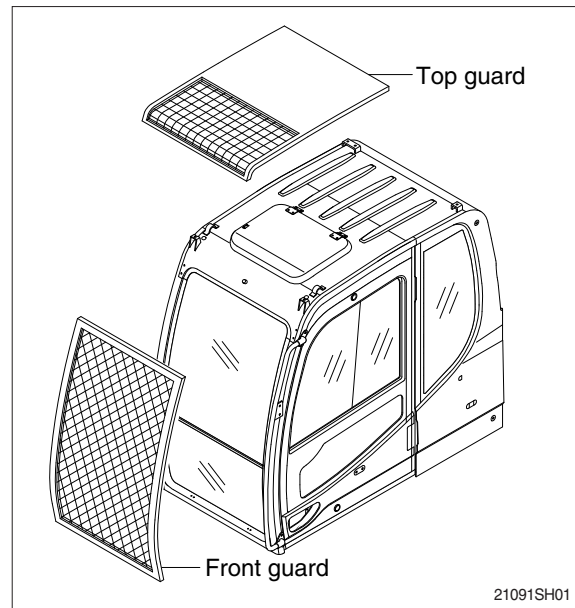

UNAUTHORIZED MODIFICATION

Any modification made without authorization from Hyundai can create hazards.

Before making a modification, consult your Hyundai distributor. Hyundai will not be responsible for any injury or damage caused by any unauthorized modification.

PREPARE FOR EMERGENCY

Only in case of emergency, use the installed hammer for breaking the windshield of the cab, and then exit carefully.

Be sure you know the phone numbers of persons you should contact in case of an emergency.

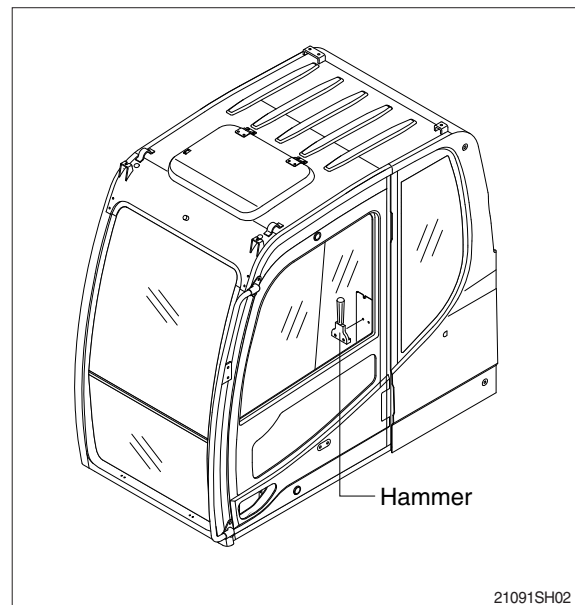

3. DURING MAINTENANCE

Stop the engine immediately when the trouble of the machine is found.

Inspect immediately the cause of trouble such as vibration, overheating and trouble in the cluster then repair.

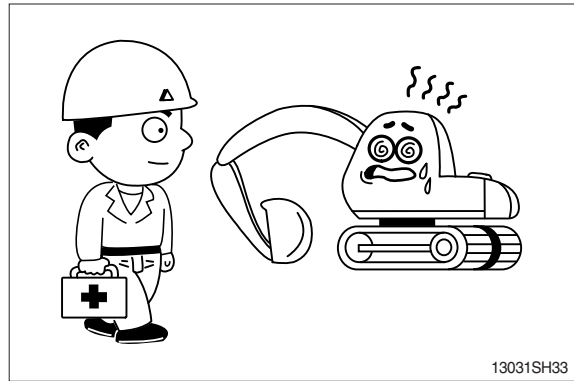

Park on a flat place and stop the engine for inspecting and repairing. Properly TAG machine is not operational. (remove start key)
Extreme care shall be taken during maintenance work. Parts may require additional safe guard.

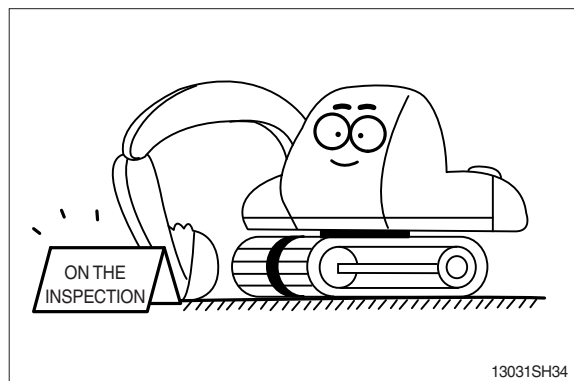

Do not remove the radiator cap from hot engine. Open the cap after the engine cools, below 50 °C (122 °F) to prevent personal injury from heated coolant spray or steam.

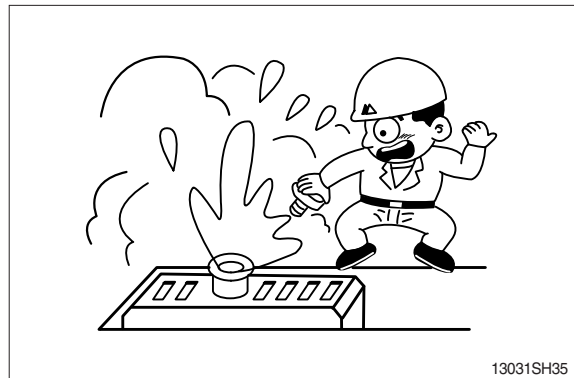

Do not work below the machine.
Be sure to work with proper safety supports.
Do not depend on the hydraulic cylinders to hold up the equipment and attachment.

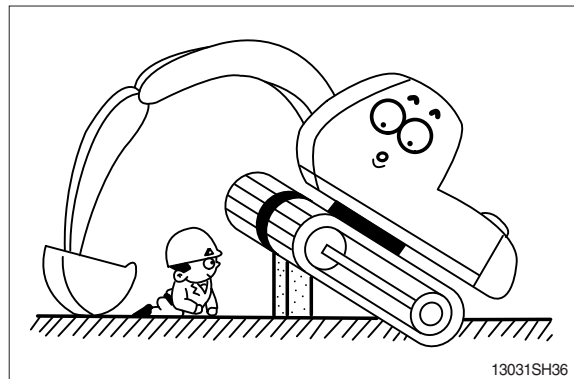

4. WEIGHT

Item	R160LC-9S		R160LCD-9S	
	kg	lb	kg	lb
Upper structure assembly	7880	17370	←	
Main frame weld assembly	1440	3180	←	
Engine assembly	430	950	←	
Fan clutch assembly	45	100	←	
Main pump assembly	90	200	←	
Main control valve assembly	135	300	←	
Swing motor assembly	240	530	←	
Hydraulic oil tank assembly	165	360	←	
Fuel tank assembly	130	290	←	
Counterweight	2900	6390	←	
Cab assembly	440	970	←	
Lower chassis assembly	6900	15210	7900	17420
Track frame weld assembly	2100	4630	2080	4590
Swing bearing	260	570	←	
Travel motor assembly	300	660	←	
Turning joint	60	130	←	
Track recoil spring	140	310	←	
Idler	160	350	←	
Carrier roller	20	45	←	
Track roller	40	90	←	
Track-chain assembly (600 mm standard triple grouser shoe)	1160	2560	←	
Front attachment assembly (5.1 m boom, 2.6 m arm, 0.7 m ³ SAE heaped bucket)	3020	6660	←	
5.1 m boom assembly	1060	2340	←	
2.6 m arm assembly	560	1240	←	
0.7 m ³ SAE heaped bucket	540	1190	←	
Boom cylinder assembly	155	340	←	
Arm cylinder assembly	180	400	←	
Bucket cylinder assembly	125	280	←	
Bucket control link assembly	120	265	←	
Dozer blade assembly	-	-	655	1445
Dozer blade cylinder assembly	-	-	66	146

7) CYLINDER

Item		Specification
Boom cylinder	Bore dia × Rod dia × Stroke	Ø115×Ø80×1090 mm
	Cushion	Extend only
Arm cylinder	Bore dia × Rod dia × Stroke	Ø120×Ø85×1355 mm
	Cushion	Extend and retract
Bucket cylinder	Bore dia × Rod dia × Stroke	Ø110×Ø75×995 mm
	Cushion	Extend only
Dozer cylinder	Bore dia × Rod dia × Stroke	Ø110×Ø85×320 mm
	Cushion	Extend only
Boom cylinder (adjust boom)	Bore dia × Rod dia × Stroke	Ø115×Ø80×960 mm
	Cushion	Extend only
Adjust cylinder	Bore dia × Rod dia × Stroke	Ø160×Ø95×650 mm
	Cushion	Extended only

※ Discoloration of cylinder rod can occur when the friction reduction additive of lubrication oil spreads on the rod surface.

※ Discoloration does not cause any harmful effect on the cylinder performance.

8) SHOE

Item		Width	Ground pressure	Link quantity	Overall width
R160LC-9S	Option	500 mm (20")	0.51 kgf/cm ² (7.25 psi)	49	2490 mm (8' 2")
	Standard	600 mm (24")	0.43 kgf/cm ² (6.11 psi)	49	2590 mm (8' 6")
	Option	700 mm (28")	0.38 kgf/cm ² (5.40 psi)	49	2690 mm (8' 10")

9) BUCKET

Item	Capacity		Tooth quantity	Width	
	SAE heaped	CECE heaped		Without side cutter	With side cutter
R160LC-9S	0.39 m ³ (0.51 yd ³)	0.34 m ³ (0.44 yd ³)	3	620 mm (24.4")	740 mm (29.1")
	0.50 m ³ (0.65 yd ³)	0.44 m ³ (0.58 yd ³)	4	760 mm (29.9")	880 mm (34.6")
	0.64 m ³ (0.84 yd ³)	0.55 m ³ (0.72 yd ³)	5	920 mm (36.2")	1040 mm (40.9")
	0.70 m ³ (0.92 yd ³)	0.60 m ³ (0.78 yd ³)	5	990 mm (39.0")	1110 mm (43.7")
	0.89 m ³ (1.16 yd ³)	0.77 m ³ (1.01 yd ³)	6	1220 mm (48.0")	1340 mm (52.8")
	◆0.69 m ³ (0.90 yd ³)	0.62 m ³ (0.81 yd ³)	5	990 mm (39.0")	-

◆ : Heavy duty bucket

5) SWITCHES

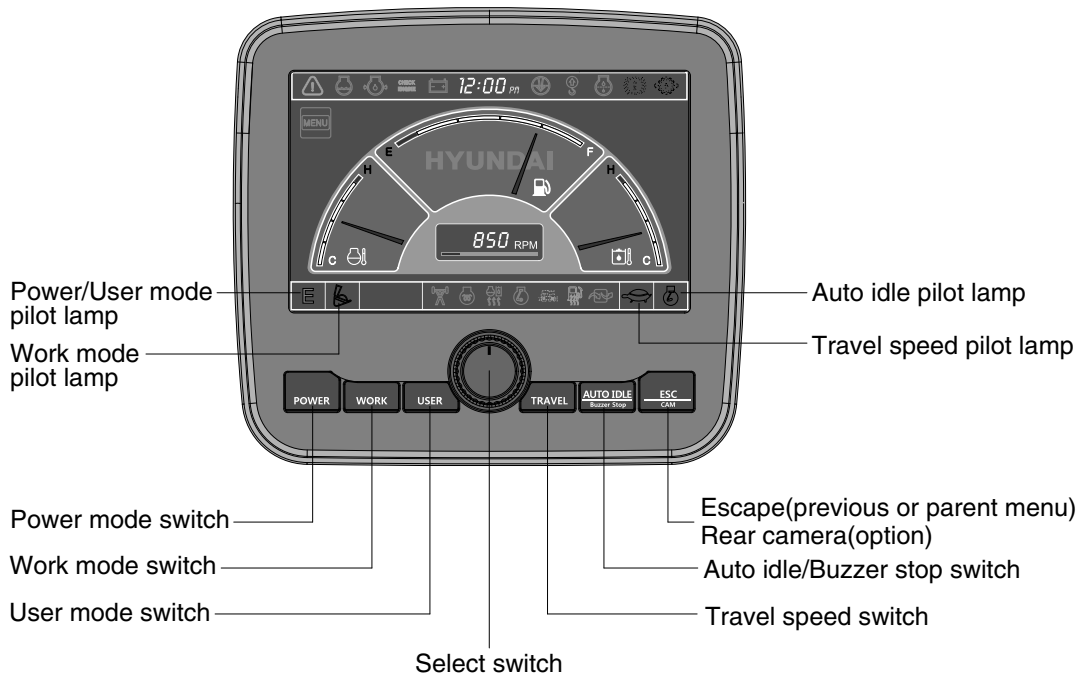

21093CD45

※ When the switches are selected, the pilot lamps are displayed on the LCD. Refer to the page 3-7 for details.

(1) Power mode switch

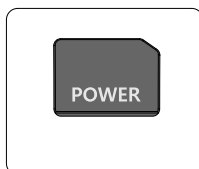

21093CD45A

- ① This switch is to select the machine power mode and selected power mode pilot lamp is displayed on the pilot lamp position.
 - P : Heavy duty power work.
 - S : Standard power work.
 - E : Economy power work.
- ② The pilot lamp changes E → S → P → E in order.

(2) Work mode switch



21093CD45C

①



※ Refer to the page 4-7 for details.

(5) Display

① Display item

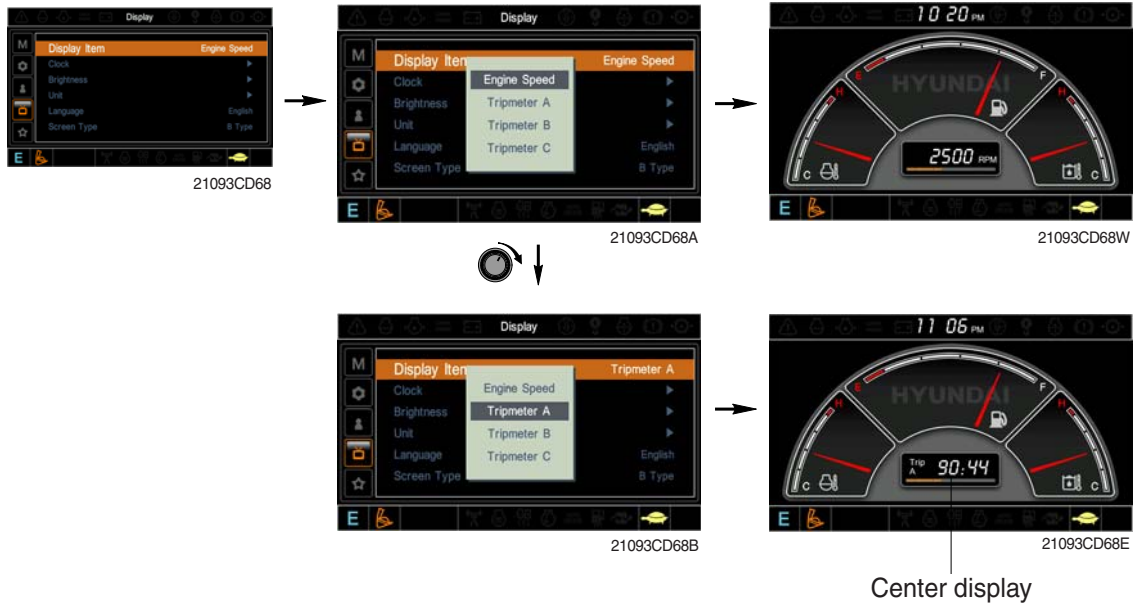

- The center display type of the LCD can be selected by this menu.
- The engine speed or each of the tripmeter (A,B,C) is displayed on the center display.

② Clock

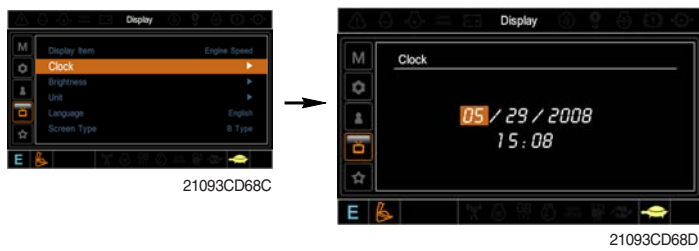

- The first line's three spots "**/**/****" represent Month/Day/Year each.
- The second line shows the current time. (0:00~23:59)

3) SAFETY LEVER

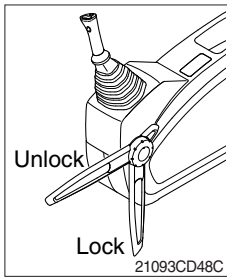

- (1) All control levers and pedals are disabled from operation by locating the lever to lock position as shown.
 - ※ **Be sure to lower the lever to LOCK position when leaving from operator's seat.**
- (2) By pull lever to UNLOCK position, the machine is operational.
 - ※ **Do not use the safety lever for handle when getting on or off the machine.**

4) TRAVEL LEVER

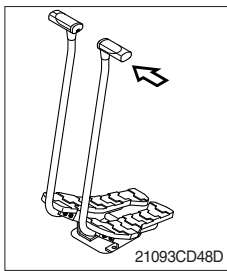

- (1) This lever is mounted on travel pedal and used for traveling by hand. The operation principle is same as the travel pedal.
- (2) Refer to traveling of the machine in chapter 4 for details.

5) TRAVEL PEDAL

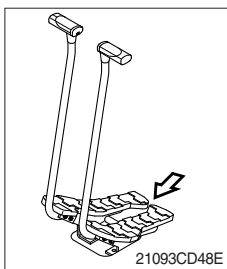

- (1) This pedal is used to move the machine forward or backward.
- (2) If left side pedal is pressed, left track will move.
If right side pedal is pressed, right track will move.
- (3) Refer to traveling of machine in chapter 4 for details.

6) SEAT AND CONSOLE BOX ADJUST LEVER

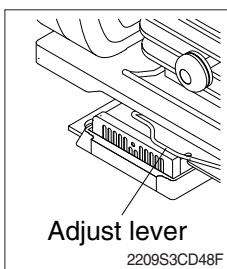

- (1) This lever is used to move the seat and console box to fit the contours of the operator's body.
- (2) Pull the lever to adjust forward or backward over 170 mm (6.7").

7) DOZER CONTROL LEVER (option)

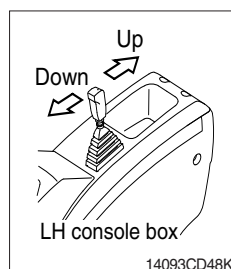

- (1) This lever is used to operate the dozer blade.
- (2) If the lever is pushed forward, the dozer blade will be going down. And the lever is pulled back, the dozer blade will be going up.

CLICK HERE TO **DOWNLOAD** THE COMPLETE MANUAL

- Thank you very much for reading the preview of the manual.
- You can download the complete manual from: www.heydownloads.com by clicking the link below



- Please note: If there is no response to CLICKING the link, please download this PDF first and then click on it.

CLICK HERE TO **DOWNLOAD** THE COMPLETE MANUAL

■GENERAL

(1) Power and volume button

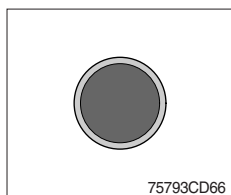

① Power ON/OFF button

Press power button to turn the unit ON or OFF shortly.

When the power is ON, the previous mode (last memory) will appear.

② Volume up / down control

Turn volume up / down button right to increase the volume level. The level will be shown in VOLUME xx on the LCD display. Turn it left to decrease the volume level. After 5 seconds of volume indication, display will return to the previous mode.

(2) Sound function selection button (audio selection)

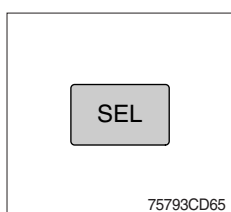

① This button is to adjust the sound. Each time you press power button shortly, LCD displays each mode as follows :

BASS → TREBLE → BAL → BEEP → LOUD → VOLUME
↑

※ When this button is pressed, LCD display shows selected function for 5 seconds and then returns back to the previous mode. On selected function, level can be controlled by turning this button. The display will automatically return to normal indication in 5 seconds after the last adjustment is made or when another function is activated.

② Bass control

To adjust the bass level, first select the bass mode by pressing the select button  until BASS indication appears on the LCD display. Within 5 seconds of choosing the bass mode, turn power button right / left to adjust the bass level as desired.

The bass level will be shown on the LCD display from a minimum of BASS -10 to a maximum of BASS +10.

The display will automatically return to the normal indication in 5 seconds after the last adjustment or when another function is activated.

③ Treble control

To adjust the treble level, first select the treble mode by pressing the select button  until TREBLE indication appears on the LCD display. Within 5 seconds of choosing the treble mode, turn power button right / left to adjust the treble level as desired.

The treble level will be shown on the LCD display from a minimum of TREBLE -10 to a maximum of TREBLE +10.

The display will automatically return to the normal indication in 5 seconds after the last adjustment or when another function is activated.

8) SERVICE METER

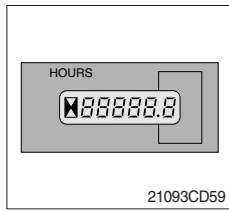

- (1) This meter shows the total operation hours of the machine.
- (2) Always ensure the operating condition of the meter during the machine operation. Inspect and service the machine based on hours as indicated in chapter 6, maintenance.

9) RS232 SERVICE SOCKET

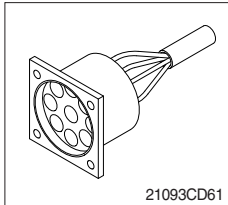

- (1) MCU communicates the machine data with Laptop computer through RS232 service socket.

10) UPPER WINDSHIELD

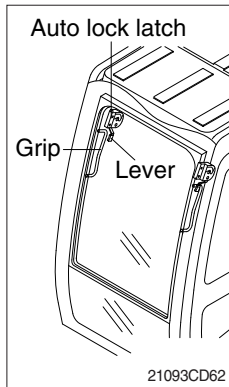

- (1) Perform the following procedure in order to open the upper windshield.
 - ① Pull both levers with hold both grips that are located at the top of the windshield frame and push the windshield upward.
 - ② Hold both grips and back into the lock position until auto lock latch is engaged, then release the lever locked position.

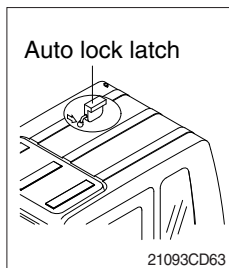

- (2) Perform the following procedure in order to close the upper windshield.
 - ① Pull the lever of the auto lock latch in order to release the auto lock latch.
 - ② Reverse above step ① and ② in order to close the upper windshield.

(2) After engine start

- ① When the engine is started, rpm display indicates low idle, 1000 ± 100 rpm.
- ② If coolant temperature is below 30°C , the warming up pilot lamp lights ON and after 4 seconds the engine speed increases to 1150 ± 100 rpm automatically to warm up the machine.
 - After 2-3 minutes, you can select any mode depending on job requirement.

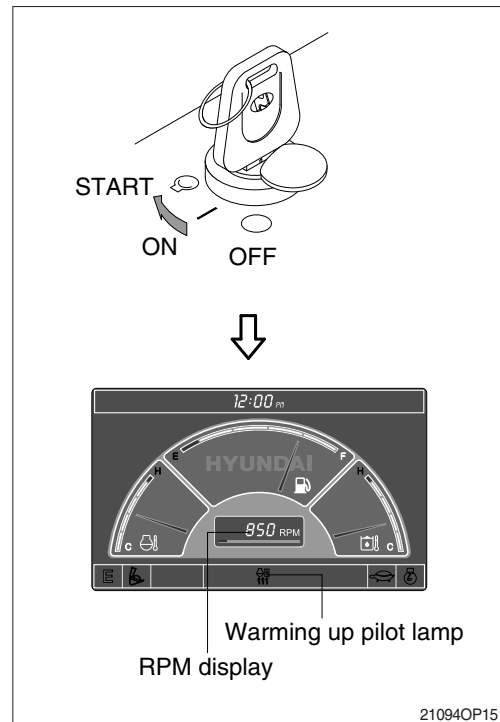

3) SELECTION OF POWER MODE

(1) E mode

The accel dial is set 10 and the auto idle mode is canceled.

Engine rpm	Effect
1800 ± 50	Variable power control in proportion to lever stroke (improvement in fuel efficiency) ※ Same power as S mode in full lever operation.

※ When the accel dial is located below 9 the engine speed decreases about 50~100 rpm per dial set.

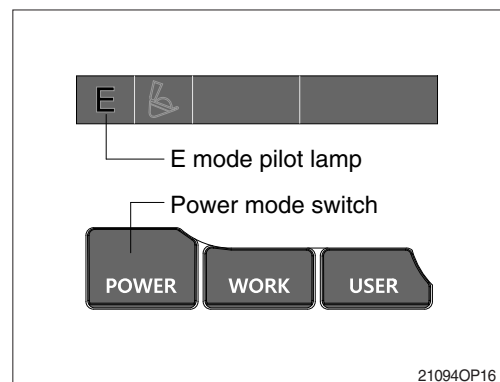

(2) S mode

The accel dial is set 10 and the auto idle mode is canceled.

Engine rpm	Effect
1900 ± 50	Standard power

※ When the accel dial is located below 9 the engine speed decreases about 50~100 rpm per dial set.

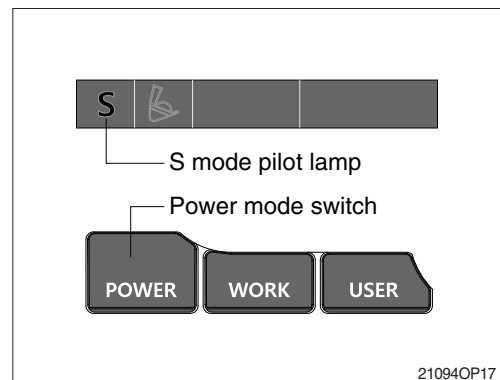

8. OPERATION IN THE SPECIAL WORK SITES

1) OPERATION THE MACHINE IN A COLD WEATHER

- (1) Use proper engine oil and fuel for the weather.
- (2) Fill the required amount of antifreeze in the coolant.
- (3) Refer to the starting engine in cold weather.
Start the engine and extend the warming up operation.
- (4) Be sure to open the heater cock when using the heater.
- (5) Always keep the battery completely charged.
※ **Discharged batteries will freeze more easily than fully charged.**
- (6) Clean the machine and park on the wood plates.

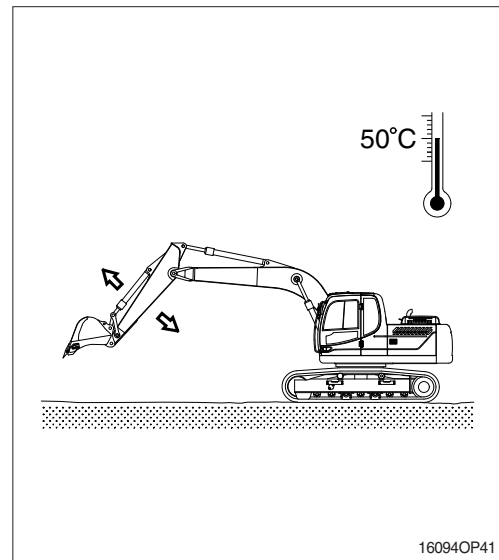

2) OPERATION IN SANDY OR DUSTY WORK SITES

- (1) Inspect air cleaner element frequently. Clean or replace element more frequently, if warning lamp comes ON and buzzer sounds simultaneously, regardless of inspection period.
※ **Replace the inner and outer element after 4 times of cleaning.**
- (2) Inspect radiator, oil cooler and condenser frequently, and keep cooling fins clean.
- (3) Prevent sand or dust from getting into fuel tank and hydraulic tank during refilling.
- (4) Prevent sand or dust from penetrating into hydraulic circuit by tightly closing breather cap of hydraulic oil tank. Replace hydraulic oil filter and air breather element frequently. Also, replace the fuel filter frequently.
- (5) Keep all lubricated part, such as pins and bushings, clean at all times.
- (6) If the air conditioner and heater filters clogged, the heating or cooling capacity will drop. Clean or replace the filter element more frequently.
- (7) Clean electrical components, especially the starting motor and alternator to avoid accumulation of dust.

(5) Boom cylinder

Mark	Description	Unit	Specification
L	Length	mm (ft-in)	1780 (5' 10")
H	Height	mm (ft-in)	230 (0' 9")
W	Width	mm (ft-in)	330 (1' 1")
Wt	Weight (2EA)	kg (lb)	320 (705)

※ Included piping.

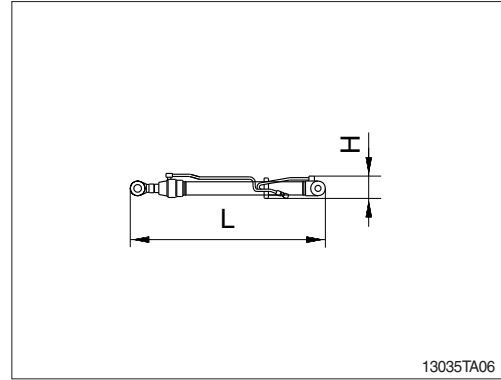

(6) Cab assembly

Mark	Description	Unit	Specification
L	Length	mm (ft-in)	2000 (6' 7")
H	Height	mm (ft-in)	1740 (5' 9")
W	Width	mm (ft-in)	1288 (4' 2")
Wt	Weight	kg (lb)	440 (970)

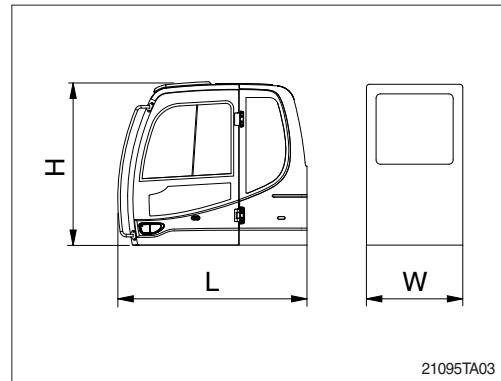

(7) Counterweight

Mark	Description	Unit	Specification
L	Length	mm (ft-in)	2475 (8' 1")
H	Height	mm (ft-in)	1050 (3' 5")
W	Width	mm (ft-in)	440 (1' 5")
Wt	Weight	kg (lb)	2900 (6395)

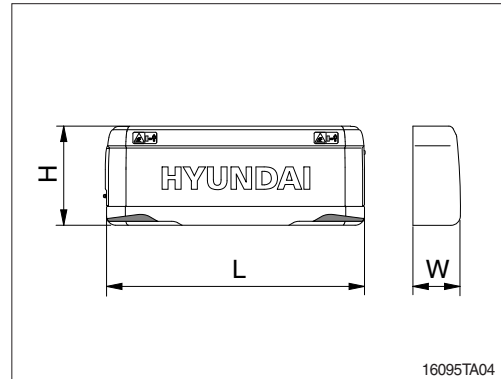

(8) 1st boom

Mark	Description	Unit	Specification
L	Length	mm (ft-in)	2110 (6' 11")
H	Height	mm (ft-in)	830 (2' 9")
W	Width	mm (ft-in)	590 (1' 11")
Wt	Weight	kg (lb)	770 (1700)

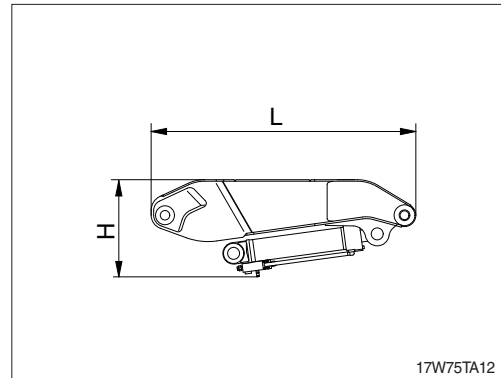

6) PERIODICAL REPLACEMENT OF SAFETY PARTS

(1) It is desirable to do periodic maintenance the machine for using the machine safely for a long time.

However, recommend to replace regularly the parts related safety not only safety but maintain satisfied performance.

(2) These parts can cause the disaster of life and material as the quality changes by passing time and it is worn, diluted, and gets fatigued by using repeatedly.

These are the parts which the operator can not judge the remained lifetime of them by visual inspection.

(3) Repair or replace if an abnormality of these parts is found even before the recommended replacement interval.

Periodical replacement of safety parts			Interval
Engine		Fuel hose (tank-engine)	Every 2 years
		Heater hose (heater-engine)	
Hydraulic system	Main circuit	Pump suction hose	Every 2 years
		Pump delivery hose	
		Swing hose	
Working device	Working device	Boom cylinder line hose	Every 2 years
		Arm cylinder line hose	
		Bucket cylinder line hose	

※ 1. Replace O-ring and gasket at the same time when replacing the hose.

2. Replace clamp at the same time if the hose clamp is cracked when checking and replacing the hose.

11) WHEN REQUIRED

Whenever you have trouble in the machine, you must perform the service of related items, system by system.

Check items	Service	Page
Fuel system		
· Fuel tank	Drain or Clean	6-25
· Prefilter	Clean or Replace	6-26
· Fuel filter element	Replace	6-27
Engine lubrication system		
· Engine oil	Change	6-18, 19
· Engine oil filter	Replace	6-18, 19
Engine cooling system		
· Coolant	Add or Change	6-20, 21, 22, 23
· Radiator	Clean or Flush	6-20, 21, 22, 23
Engine air system		
· Air cleaner element	Replace	6-25
Hydraulic system		
· Hydraulic oil	Add or Change	6-31,32
· Return filter	Replace	6-33
· Drain line filter	Replace	6-33
· Pilot line filter	Replace	6-34
· Element of breather	Replace	6-33
· Suction strainer	Clean	6-32
Under carriage		
· Track tension	Check, Adjust	6-36
Bucket		
· Tooth	Replace	6-39
· Side cutter	Replace	6-39
· Linkage	Adjust	6-40
· Bucket assy	Replace	6-38
Air conditioner and heater		
· Fresh air filter	Clean, Replace	6-45
· Recirculation filter	Clean	6-46

8) CLEANING OF AIR CLEANER

(1) Primary element

- ① Loosen the clamps and remove the element.
 - ② Clean the inside of the body.
 - ③ Clean the element with pressurized air.
· Remove the dust inside of the element by the pressurized air (below 3 kgf/cm², 40 psi) forward and backward equally.
 - ④ Inspect for cracks or damage of element by putting a light bulb inside of the element.
 - ⑤ Insert element and tighten wing nut.
- ※ **Replace the primary element after 4 times cleanings.**

(2) Safety element

- ※ **Replace the safety element only when the primary element is cleaned for the 4 times.**
- ※ **Always replace the safety element. Never attempt to reuse the safety element by cleaning the element.**

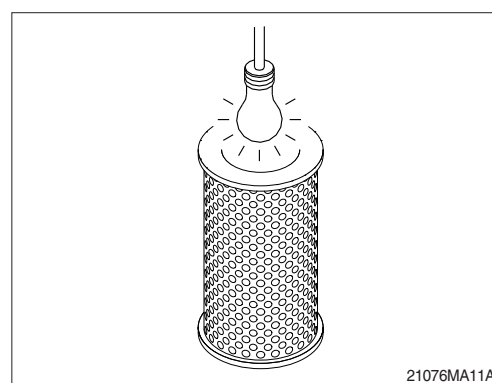
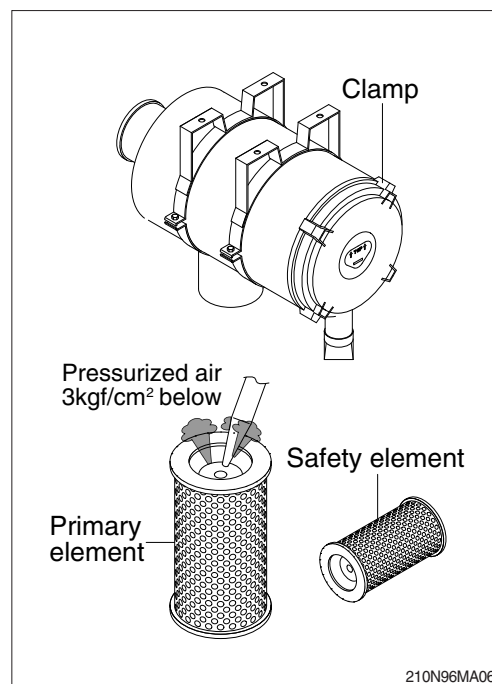

9) FUEL TANK

- (1) Fill fuel fully when system the operation to minimize water condensation, and check it with fuel gauge before starting the machine.
 - (2) Drain the water and sediment in the fuel tank by opening the drain cock.
※ **Be sure to LOCK the cap of fuel tank.**
※ **Remove the strainer of the fuel tank and clean it if contaminated.**
- ▲ **Stop the engine when refueling.**
All lights and flames shall be kept at a safe distance while refueling.

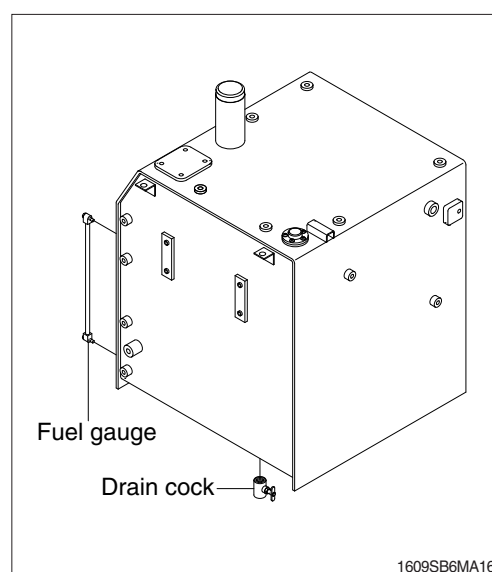

26) LUBRICATE SWING BEARING

- (1) Grease at 3 fitting.
- ※ Lubricate every 250 hours.

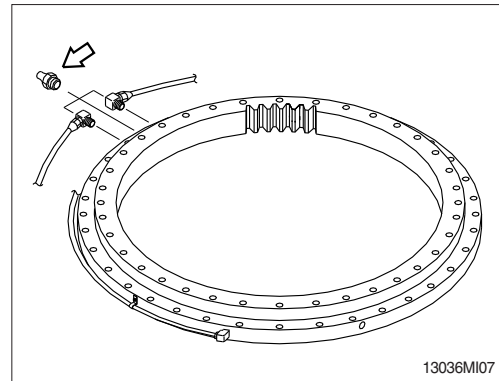

27) SWING GEAR AND PINION

(1) Drain old grease

- ① Remove under cover of lower frame.
- ② Remove drain cover of lower frame.
- ③ Remove filler cover of upper frame.
- ④ Operate full turn (360°) of swing several times.

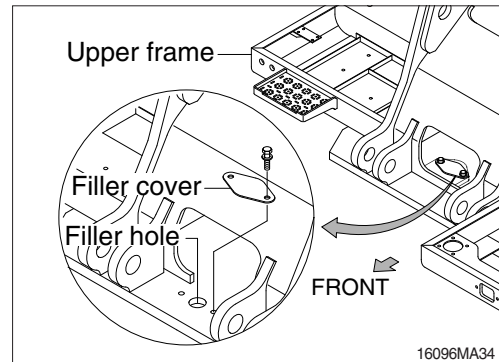

(2) Refill new grease

- ① Install drain cover.
 - ② Fill with new grease.
 - ③ Install filler cover.
- Capacity : 7.9 kg (17.5 lb)

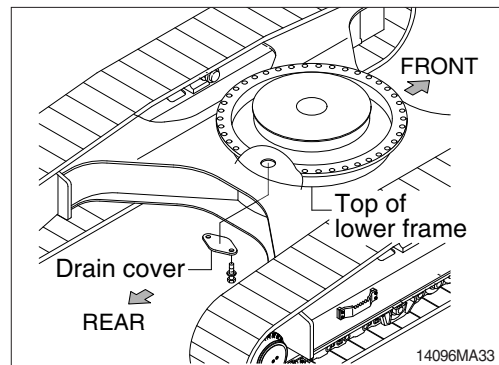

28) CHECK THE TRAVEL REDUCTION GEAR OIL

- (1) Operate the machine to the position of drain plug down to the flat ground.
 - (2) Loosen the level plug and check the oil level.
If the level is at the hole of the plug, it is normal.
Fill the oil if it is not sufficient.
- Amount of gear oil : 5.8l(1.5 U.S.gal)

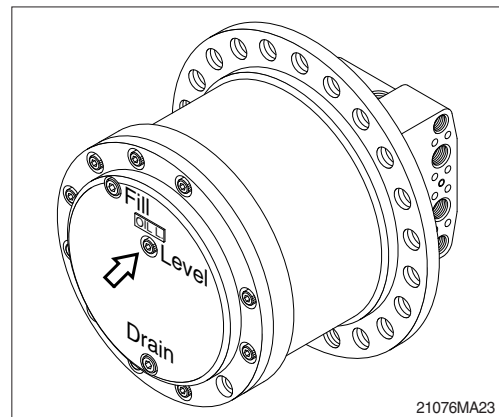

8. AIR CONDITIONER AND HEATER

1) CLEAN AND REPLACE OF FRESH AIR FILTER

※ Always stop the engine before servicing.

(1) Open the LH side cover.

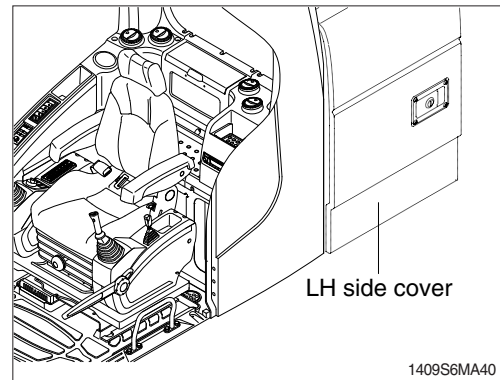

(2) Remove the fresh air filter.

※ When installing a filter, be careful not to change the filter direction.

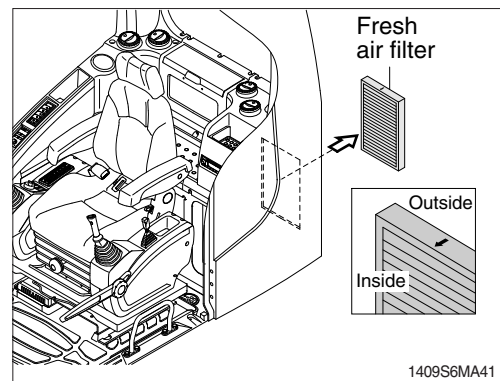

(3) Clean the filter using a pressurized air (below 2 kgf/cm², 28 psi).

△ When using pressurized air, be sure to wear safety glasses.

(4) Inspect the filter after cleaning. If it is damaged or badly contaminated, use a new filter.

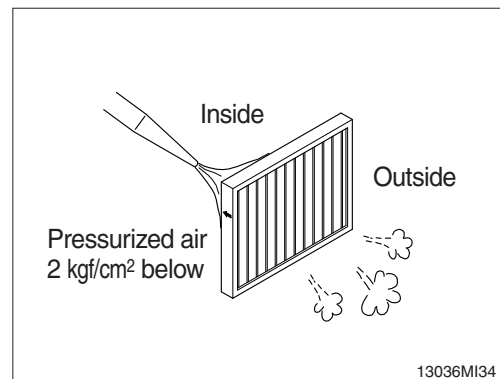

2) CLEAN AND REPLACE OF RECIRCULATION FILTER

※ Always stop the engine before servicing.

(1) Move seat and console box to arrow direction using the adjust lever.

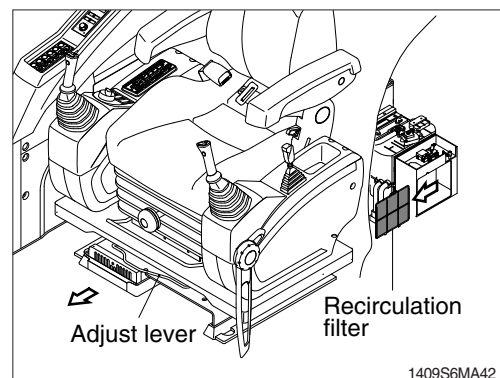

CLICK HERE TO **DOWNLOAD** THE COMPLETE MANUAL

- Thank you very much for reading the preview of the manual.
- You can download the complete manual from: www.heydownloads.com by clicking the link below



- Please note: If there is no response to CLICKING the link, please download this PDF first and then click on it.

CLICK HERE TO **DOWNLOAD** THE COMPLETE MANUAL