

# CONTENTS

EC declaration of conformity .....	0-1	8. Operation in the special work sites .....	4-19
Foreword .....	0-2	9. Normal operation of excavator .....	4-21
Before servicing this machine .....	0-3	10. Attachment lowering .....	4-22
EC regulation approved .....	0-4	11. Storage .....	4-23
Table to enter S/No and distribution .....	0-5	12. RCV lever operating pattern .....	4-25
Safety labels .....	0-6	13. Switching hydraulic attachment circuit .....	4-27
Machine data plate .....	0-19		
Guide (direction, S/No, symbol) .....	0-20		
<b>SAFETY HINTS</b>		<b>TRANSPORTATION</b>	
1. Before operating the machine .....	1-1	1. Preparation for transportation .....	5-1
2. During operating the machine .....	1-16	2. Dimension and weight .....	5-2
3. During maintenance .....	1-23	3. Disassembling for transportation .....	5-5
4. Parking .....	1-26	4. Loading the machine .....	5-8
		5. Fixing the machine .....	5-10
		6. Adjustable track gauge .....	5-11
<b>SPECIFICATIONS</b>		<b>MAINTENANCE</b>	
1. Major components .....	2-1	1. Instruction .....	6-1
2. Specifications .....	2-2	2. Tightening torque .....	6-6
3. Working range .....	2-3	3. Fuel, coolant and lubricants .....	6-9
4. Weight .....	2-4	4. Maintenance check list .....	6-11
5. Lifting capacities .....	2-5	5. Maintenance chart .....	6-16
6. Bucket selection guide .....	2-6	6. Service instruction .....	6-18
7. Undercarriage .....	2-7	7. Electrical system .....	6-44
8. Specification for major components .....	2-9	8. Air conditioner and heater .....	6-47
9. Recommended oils .....	2-12		
<b>CONTROL DEVICES</b>		<b>TROUBLESHOOTING GUIDE</b>	
1. Cab devices .....	3-1	1. Engine .....	7-1
2. Cluster .....	3-2	2. Electrical system .....	7-2
3. Switches .....	3-23	3. Others .....	7-3
4. Levers and pedals .....	3-28		
5. Air conditioner and heater .....	3-30	<b>HYDRAULIC BREAKER AND QUICK CLAMP</b>	
6. Others .....	3-37	1. Selecting hydraulic breaker .....	8-1
		2. Circuit configuration .....	8-2
<b>OPERATION</b>		3. Maintenance .....	8-3
1. Suggestion for new machine .....	4-1	4. Precaution while operating the breaker .....	8-4
2. Check before starting the engine .....	4-2	5. Quick clamp .....	8-6
3. Starting and stop the engine .....	4-3		
4. Mode selection system .....	4-6	<b>OTHERS</b>	
5. Operation of the working device .....	4-11	1. Central grease lubrication system .....	9-1
6. Traveling of the machine .....	4-12	2. Semi auto grease lubrication system .....	9-8
7. Efficient working method .....	4-15		
		<b>INDEX</b> .....	10-1

CLICK HERE TO **DOWNLOAD** THE COMPLETE MANUAL

- Thank you very much for reading the preview of the manual.
- You can download the complete manual from: [www.heydownloads.com](http://www.heydownloads.com) by clicking the link below



- Please note: If there is no response to CLICKING the link, please download this PDF first and then click on it.

CLICK HERE TO **DOWNLOAD** THE COMPLETE MANUAL

11) **SIDE KEEP CLEAR** (item 13)

This warning label is positioned on the both side of counterweight.

- ▲ To prevent serious personal injury or death keep clear of machine swing radius.
- ▲ Do not deface or remove this label from the machine.

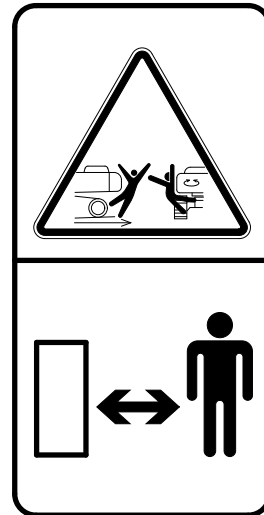

21070FW13

12) **STAY FIX** (item 14)

This warning label is positioned on the side cover.

- ▲ Be sure to support the stay when the door needs to be opened.
- ▲ Be careful that the opened door may be closed by the external or natural force like strong wind.

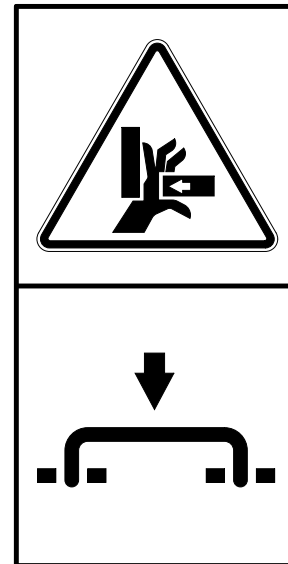

21070FW14

13) **SHEARING-ENGINE HOOD** (item 15)

This warning label is positioned on the engine hood.

- ▲ Don't open the engine hood during the engine's running.
- ▲ Don't touch exhaust pipe or it may cause severe burn.

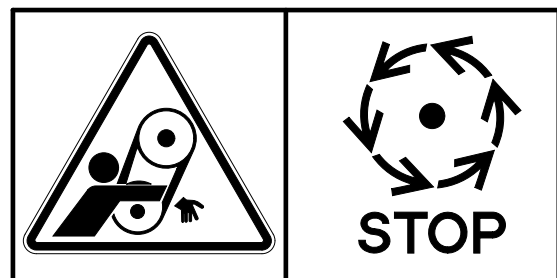

21070FW15

## GUIDE

### 1. DIRECTION

The direction of this manual indicate forward, backward, right and left on the standard of operator when the travel motor is in the rear and machine is on the traveling direction.

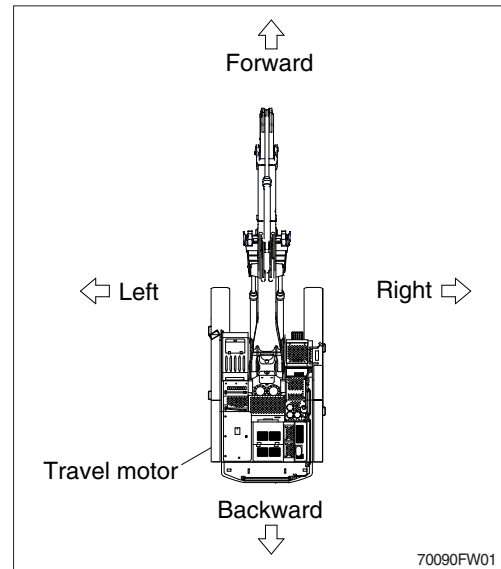

### 2. SERIAL NUMBER

Inform following when you order parts or the machine is out of order.

#### 1) MACHINE SERIAL NUMBER

The numbers are located below the right window of the operator's cab.

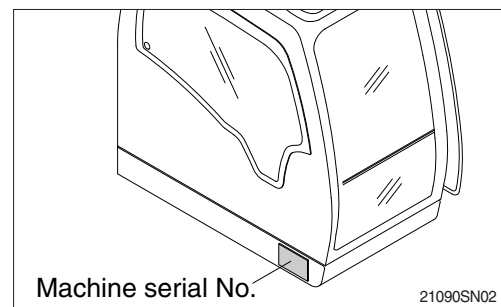

#### 2) ENGINE SERIAL NUMBER

The numbers are located on the engine name plate.

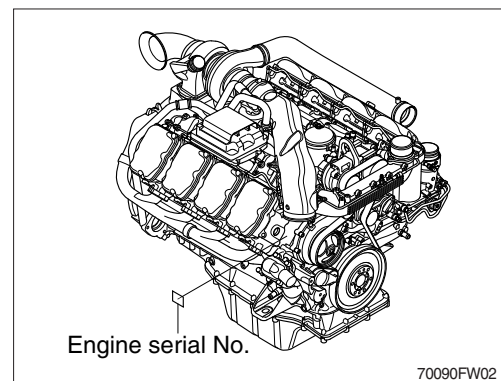

### 3. INTENDED USE

This machine is designed to be used mainly for the following work.

- Digging work
- Loading work
- Smoothing work
- Ditching work

※ Please refer to the section 4 (efficient working method) further details.

### 4. SYMBOLS

▲ Important safety hint.

△ It indicates matters which can cause the great loss on the machine or the surroundings.

※ It indicates the useful information for operator.

## **Lines, Tubes, and Hoses**

Do not bend high-pressure lines. Do not strike high-pressure lines. Do not install any lines that are bent or damaged. Use the appropriate backup wrenches in order to tighten all connections to the recommended torque.

Check lines, tubes, and hoses carefully. Wear Personal Protection Equipment (PPE) in order to check for leaks. Always use a board or cardboard when you check for a leak. Leaking fluid that is under pressure can penetrate body tissue. Fluid penetration can cause serious injury and possible death. A pin hole leak can cause severe injury. If fluid is injected into your skin, you must get treatment immediately. Seek treatment from a doctor that is familiar with this type of injury.

Replace the affected parts if any of the following conditions are present :

- End fittings are damaged or leaking.
- Outer coverings are chafed or cut.
- Wires are exposed.
- Outer coverings are swelling or ballooning.
- Flexible parts of the hoses are kinked.
- Outer covers have exposed embedded armoring.
- End fittings are displaced.

Make sure that all clamps, guards, and heat shields are installed correctly. During machine operation, this action will help to prevent vibration, rubbing against other parts, excessive heat, and failure of lines, tubes, and hoses.

Do not operate a machine when a fire hazard exists. Repair any lines that are corroded, loose, or damaged. Leaks may provide fuel for fires. Consult your Hyundai dealer for repair or for replacement parts.

## **Ether**

Ether (if equipped) is commonly used in cold weather applications. Ether is flammable and poisonous.

Do not spray ether manually into an engine if the machine is equipped with a thermal starting aid for cold weather starting.

Use ether in ventilated areas. Do not smoke while you are replacing an ether cylinder or while you are using an ether spray.

Do not store ether cylinders in living areas or in the operator compartment of a machine. Do not store ether cylinders in direct sunlight or in temperatures above 49°C(120.2 °F). Keep ether cylinders away from unauthorized personnel.

Avoid traveling in a cross direction on a slope as it can cause the danger of rolling over and sliding.

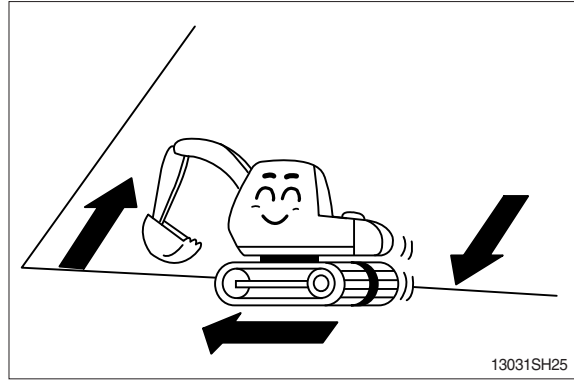

Traveling on a slope is dangerous. Be sure to operate slowly when traveling down a slope and maintain the bucket at a height of 20~30 cm (1 ft) above the ground so that it can be used as brake in an emergency.

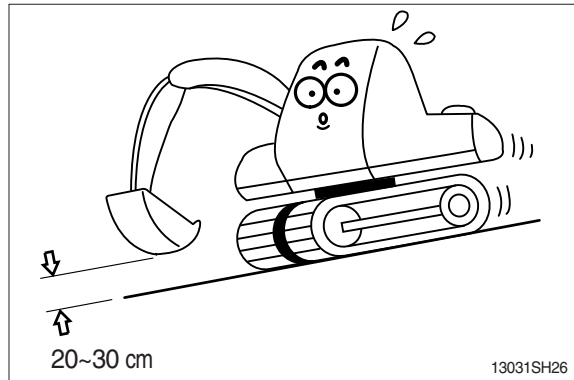

Steering of the machine while traveling on a slope is dangerous. When an inevitable turning of direction is required, turn on the flat and solid ground.

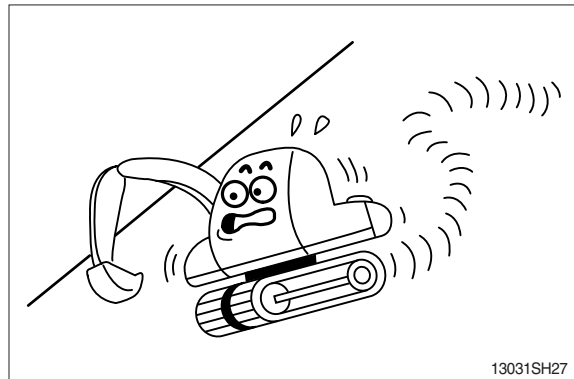

The engine angularity limits are 35 degree. Do not operate by more than the engine limits in any case.

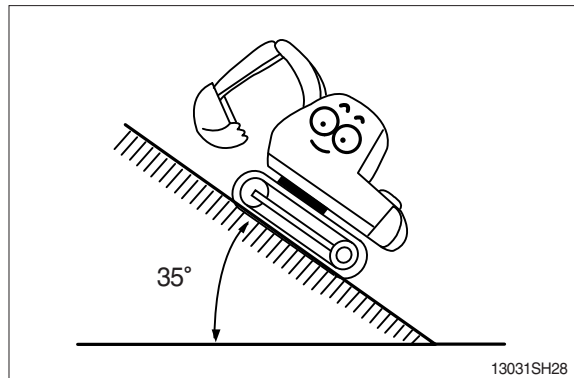

## 4. WEIGHT

Item	R700LC-9	
	kg	lb
Upperstructure assembly	35700	78700
Main frame weld assembly	6660	14680
Engine assembly	1340	2950
Main pump assembly	300	660
Main control valve assembly	420	930
Swing motor assembly	410	900
Hydraulic oil tank assembly	1860	4100
Fuel tank assembly	1825	4020
Counterweight	11000	24250
Cab assembly	490	1080
Lower chassis assembly	21420	47220
Lower track frame assy	10700	23590
Swing bearing	1300	2870
Travel motor assembly	800	1760
Turning joint	75	165
Track recoil spring and tension body	740	1630
Idler	540	1190
Sprocket	210	460
Carrier roller	75	165
Track roller	150	330
Track-chain assembly (650 mm double grouser shoe)	4270	9410
Front attachment assembly (6.8 m boom, 2.9 m arm, 4.0 m <sup>3</sup> SAE heaped bucket)	15280	33690
6.8 m boom assembly	5300	11680
2.9 m arm assembly	2440	5380
4.0 m <sup>3</sup> SAE heaped bucket	3900	8600
Boom cylinder assembly	590	1300
Arm cylinder assembly	870	1920
Bucket cylinder assembly	570	1260
Bucket control rod assembly	390	860

## 2. CLUSTER

### 1) STRUCTURE

The cluster consists of LCD and switches as shown below. The LCD is to warn the operator in case of abnormal machine operation or conditions for the appropriate operation and inspection. Also, The LCD is to set and display for modes, monitoring and utilities with the switches.

The switches are to set the machine operation modes.

- ※ **The cluster installed on this machine does not entirely guarantee the condition of the machine. Daily inspection should be performed according to chapter 6, Maintenance.**
- ※ **When the cluster provides a warning immediately check the problem, and perform the required action.**

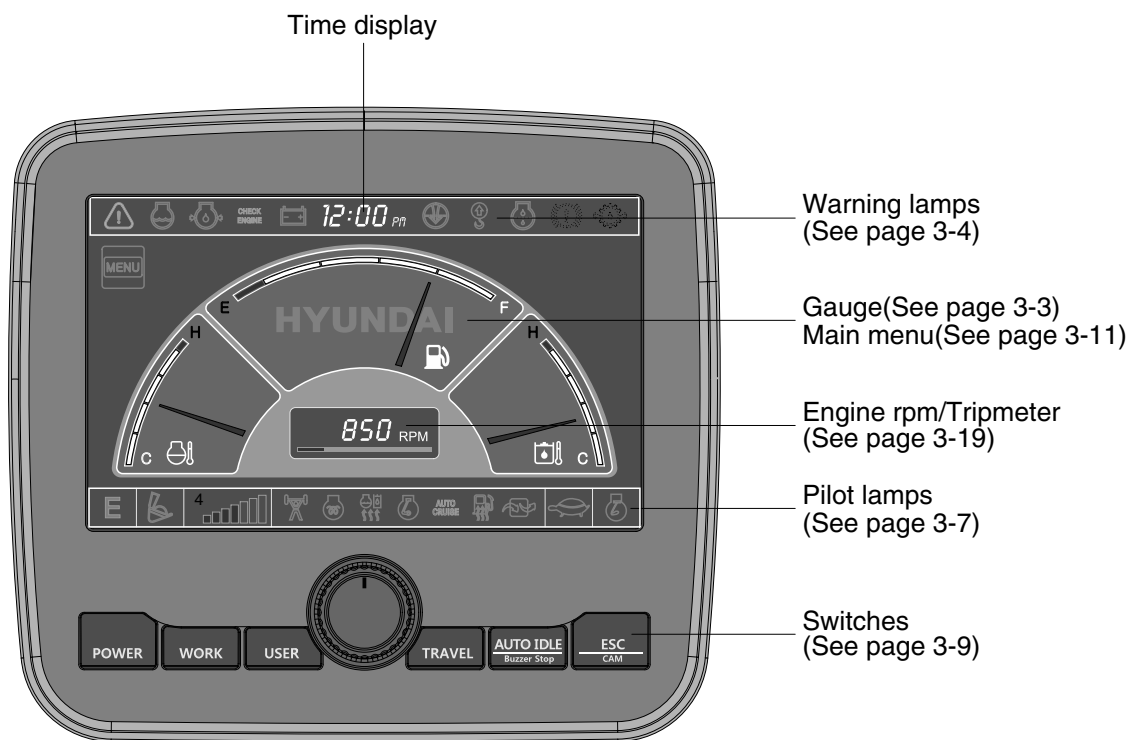

21093CD07

- ※ **The warning lamp pops up and/or blinks and the buzzer sounds when the machine has a problem.**  
The warning lamp blinks until the problem is cleared. Refer to page 3-4 for details.

## (2) Mode setup

### ① Work tool



- A : Select one installed optional attachment.
  - B : Max flow - Set the maximum flow for the attachment.  
Flow level - Reduce the operating flow from maximum flow.  
Breaker - Max 7 steps, Reduced 10 lpm each step.  
Crusher - Max 4 steps, Reduced 20 lpm each step.
- ※ The flow level is displayed with the work mode pilot lamp.

### ② U mode power

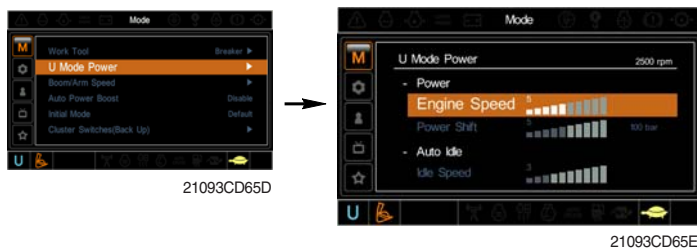

- Engine high idle rpm, auto idle rpm and pump torque (power shift) can be modulated and memorized separately in U-mode.
- U-mode can be activated by user mode switch.

Step (■)	Engine speed (rpm)	Idle speed (rpm)	Power shift (bar)
1	1400	800	0
2	1450	850	3
3	1500	900	6
4	1550	950	9
5	1600	One touch decel low idle (1000)	12
6	1650	1050	16
7	1700	Auto decel (1100)	20
8	1750	1150	26
9	1800	1200	32
10	1850	1250	38

### ③ Boom/Arm speed

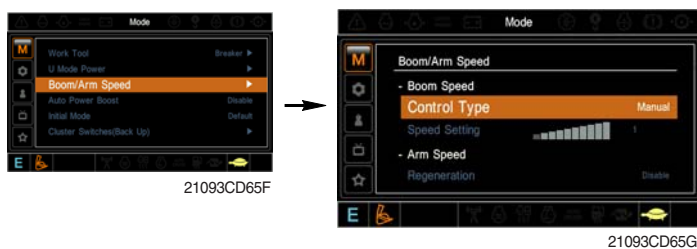

- **Boom speed**
  - Control type
    - Manual - Boom up speed is fixed as set steps.
    - Auto - Boom up speed is automatically adjusted as working conditions by the MCU.
  - Speed setting - Boom up speed is increased as much as activated steps.
- **Arm speed**
  - Regeneration - Arm regeneration function can be activated or cancelled.
    - Enable - Arm in speed is up.
    - Disable - Fine operation.

### ③ Entertainment

- Play MP4 or codec file of external hard disk through USB port.
- The USB port is located under the cluster.

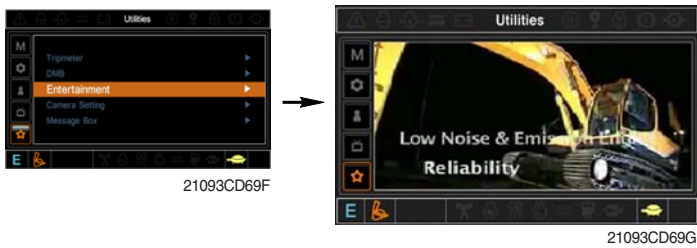

### ④ Camera setting

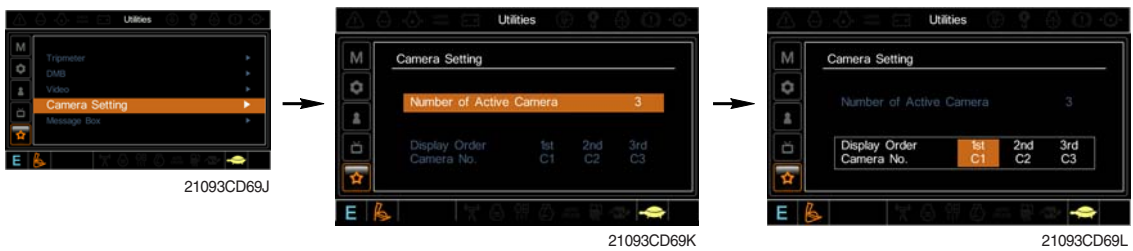

- Three cameras can be installed on the machine.
- The display order can be set by this menu.



- If the camera was not equipped, this menu is not useful.
- In the operation screen, if the ESC/CAM switch is pushed, the first ordered display camera will be viewed.
- Turning the select switch in clockwise direction, the next ordered will be shown and in counter-clockwise direction, the previously ordered will be shown.
- Push the select switch, the displayed screen will be enlargement.

### ⑤ Message box

- The history of the machine operating status can be checked by this menu.

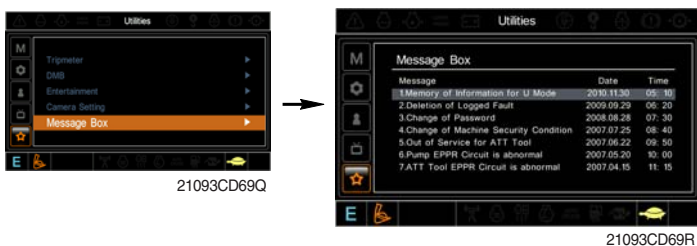

## 5) TEMPERATURE CONTROL SWITCH

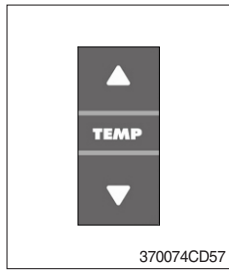

- (1) Setting temperature indication (17~32°C, scale : 1°C)
- (2) Max cool and max warm beeps 5 times.
- (3) The max cool or the max warm position operates as following table.

Temperature	Compressor	Fan speed	In/Outlet	Mode
Max cool	ON	Max (Hi)	Recirculation	Vent
Max warm	OFF	Max (Hi)	Fresh	Foot

- (4) Temperature unit can be changed between celsius (°C) and fahrenheit (°F)
  - ① Default status (°C)
  - ② Push Up/Down temperature control switch simultaneously more than 5 second displayed temperature unit change (°C → °F)

## 6) MODE SWITCH

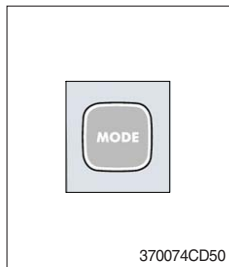

- (1) Operating this switch, it beeps and displays symbol of each mode in order.

· A type : Vent → Vent/Foot → Foot → Foot/Def → Vent

Mode switch		Vent	Vent/Foot	Foot	Foot/Def
Outlet	A	●	●		
	B		●	●	●
	C				●

· B type : Vent → Vent/Foot → Def/Foot → Def/Vent → Def/Vent/Foot

Mode switch		Vent	Vent/Foot	Def/Foot	Def/Vent	Def/Vent/Foot
Outlet	A	●	●		●	●
	B		●	●		●
	C			●	●	●

- (2) When defroster mode operating, FRESH AIR/AIR RECIRCULATION switch turns to FRESH AIR mode and air conditioner switch turns ON.

## 7) FRESH AIR/AIR RECIRCULATION SWITCH

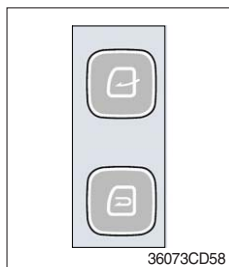

- (1) It is possible to change the air-inlet method.

① **Fresh air** ( )

Inhaling air from the outside.

※ **Check out the fresh air filter periodically to keep a good efficiency.**

② **Air recirculation** ( )

It recycles the heated or cooled air to increase the energy efficiency.

※ **Change air occasionally when using recirculation for a long time.**

※ **Check out the recirculation filter periodically to keep a good efficiency.**

#### 4) RADIO AND USB PLAYER : MACHINE SERIAL NO.: NOT USED

##### ■ BASIC FUNCTIONS

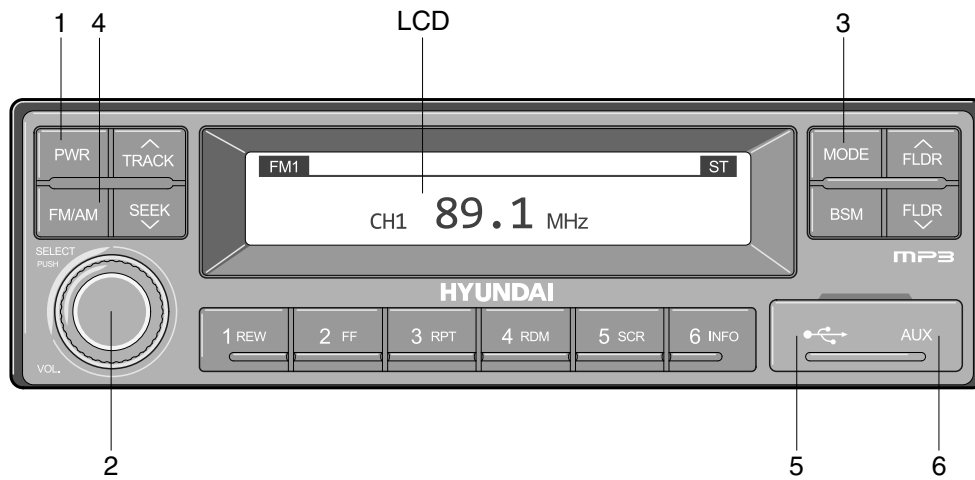

2209S3CD70

- |                               |                                  |
|-------------------------------|----------------------------------|
| 1 Power (PWR) button          | 4 Radio (FM/AM) selection button |
| 2 Volume/Sound setting button | 5 USB slot                       |
| 3 Mode selection button       | 6 AUX terminal                   |

##### (1) Power (PWR) button

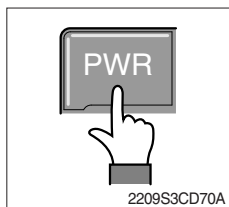

- ① Press the PWR button to turn on the audio. While the audio is operating, press the button to turn the power off.

##### (2) Volume/Sound setting button

###### · Volume (VOL) button

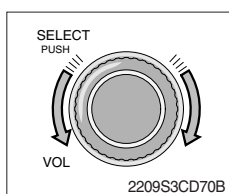

- ① Turn the VOL button clockwise to increase the volume and counter-clockwise to decrease the volume.

### (3) FF/REW button

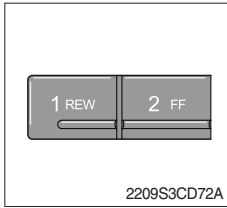

- ① While an iPod is operating, press and hold the FF button to fast-forward the song.
- ② When fast-forward is complete, the next song will properly play from the beginning even if you continue holding the button. Press and hold the REW button to rewind the song.
- ③ When rewind is complete, the current song will properly play from the beginning even if you continue holding the button.
- ④ Shortly pressing the buttons will not operate the FF/REW.

### (4) Repeat (RPT) button

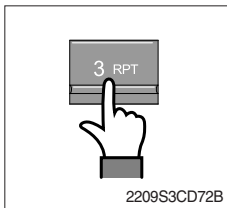

- ① While music is playing, press the RPT button to repeat the currently playing song.

### (5) Random play (RDM) button

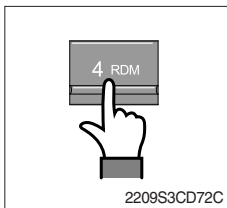

- ① While music is playing, press the RDM button to randomly play the songs.

### (6) Scroll (SCR) button

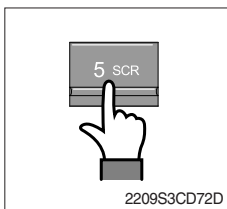

- ① Displays the file name of the currently playing song on the LCD. Here, the SCR button turns the file name SCROLL ON/OFF.

### (7) View music info (INFO) button

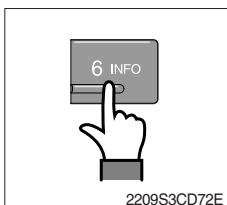

- ① Each time the INFO button is pressed, the info on the currently playing song will be displayed in order of ARTIST → ALBUM → TITLE.

## ■ USB PLAYER

### (1) USB playback



- ① The unit was equipped with a front USB jack and also a rear USB Jack.

With a USB device plugged in the front USB jack, it will be detected as front USB mode. And with a USB device plugged in the rear USB jack, it will be detected as rear USB. To get to a USB mode, press MODE (3) button momentarily or insert the USB device in front or rear USB jack.

- ※ If no mp3 or wma files in USB device, it will convert to the previous mode after display NO FILE.

### (2) Track Up / Down button



- ① Press SEEK up (13) or TRACK down (14) to select the next or previous track. Press and hold the buttons to advance the track rapidly in the forward or backward direction.



### (3) MP3 directory / File searching



- ① Button (2) is used to select a particular directory and file in the device. Turn button (2) right or left to display the available directories. Press button (2) momentarily when the desired directory is displayed, then turn button (2) right or left again to display the tracks in that directory. Press button (2) to begin playback when the desired file is displayed.

### (4) Directory Up / Down button



- ① During MP3/WMA playback, simply press DIR- button (10) to select the previous directory (if available in the device); simply press DIR+ button (11) to select the next directory (if available in the device).

- ※ If the USB device does not contain directories, it would play MP3/WMA tracks at 10- file when you press DIR- button (10), and play MP3/WMA tracks at 10+ file when you press DIR+ (11) button.

CLICK HERE TO **DOWNLOAD** THE COMPLETE MANUAL

- Thank you very much for reading the preview of the manual.
- You can download the complete manual from: [www.heydownloads.com](http://www.heydownloads.com) by clicking the link below



- Please note: If there is no response to CLICKING the link, please download this PDF first and then click on it.

CLICK HERE TO **DOWNLOAD** THE COMPLETE MANUAL



**(6) Monitoring system**

Information of machine performance as monitored by the MCU can be displayed on the LCD. Refer to the page 3-11.

**(7) Self diagnostic system**

① **MCU (Machine Control Unit)**

The MCU diagnoses machine status and problems and displays fault code in the cluster (fault code detected by MCU is composed of HCESPN and FMI).

② **Engine ECM (Electronic Control Module)**

If the engine or relevant system has problem, engine ECM detects and displays on the LCD as fault codes (this code is composed of SPN and FMI).

※ Refer to the page 3-11 for LCD display.

**(8) Anti-restart system**

The system protects the starter from inadvertent restarting after the engine is already operational.

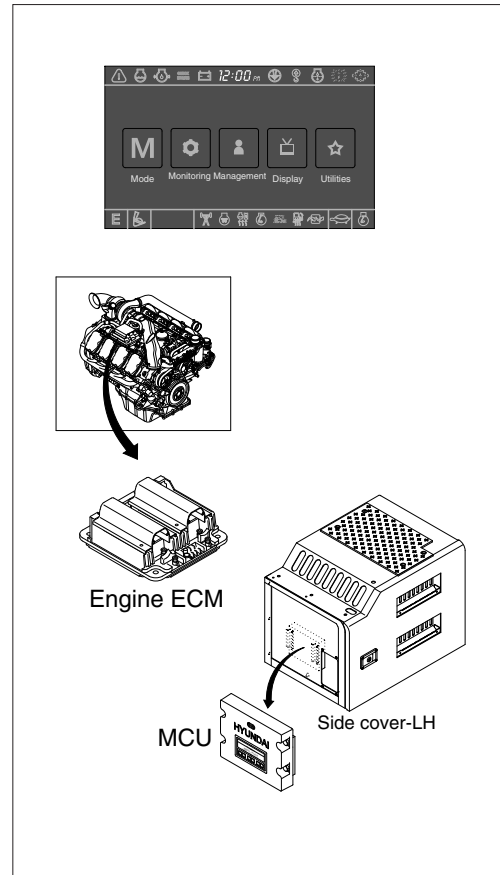

**2) HOW TO OPERATE MODE SELECTION SYSTEM**

(1) **When start key switch is turned ON**

When start key switch is turned on, the cluster turns on and buzzer sounds for 4 seconds. And then main information as gauges and engine speed are displayed on LCD.

Initial default mode settings are displayed in the cluster.

※ These setting can be changed at U mode.

③ Self-diagnostic function can be carried out from this point.

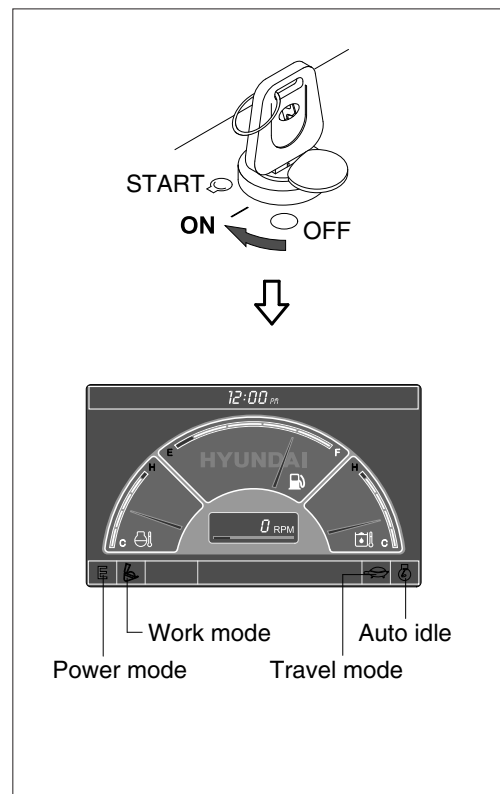

## 12) BUCKET WITH HOOK

When carrying out lifting work, the special lifting hook is necessary.

The following operations are prohibited.

- Lifting loads with a wire rope fitted around the bucket teeth.
- Lifting loads with the wire rope wrapped directly around the boom or arm.

When performing lifting operation, securely hook the wire rope onto the special lifting hook.

When performing lifting operation, never raise or lower a person.

Due to the possible danger of the load falling or of collision with the load, no persons shall be allowed in the working area.

Before performing lifting operation, designate an operation supervisor.

Always execute operation according to his instructions.

- Execute operating methods and procedures under his direction.
- Select a person responsible for signaling. Operate only on signals given by such person.

Never leave the operator's seat while lifting a load.

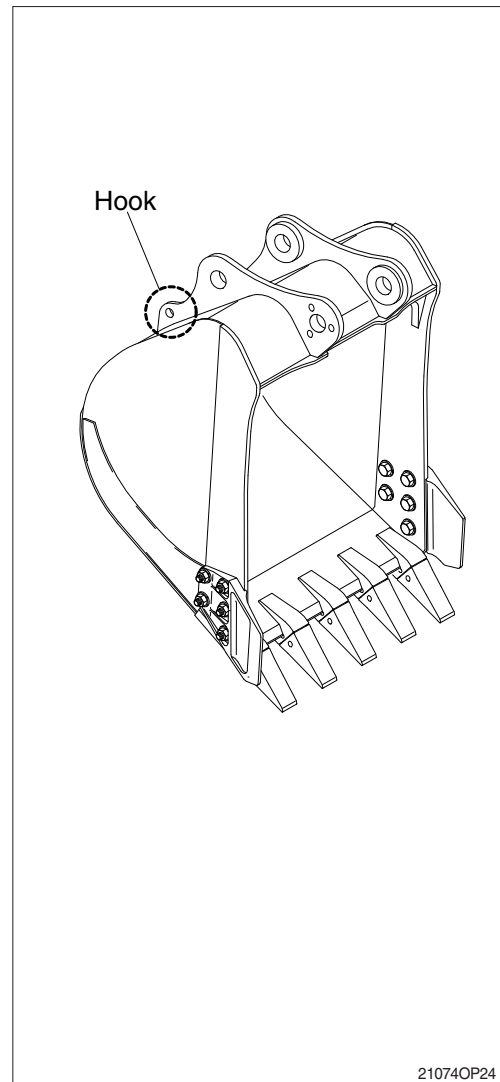

# TRANSPORTATION

## 1. PREPARATION FOR TRANSPORTATION

- 1) When transporting the machine, observe the various road rules, road transportation vehicle laws and vehicle limit ordinances, etc.
- 2) Select proper trailer after confirming the weight and dimension from the chapter 2, specification.
- 3) Check the whole route such as the road width, the height of bridge and limit of weight and etc., which will be passed.
- 4) Get the permission from the related authority if necessary.
- 5) Prepare suitable capacity of trailer to support the machine.
- 6) Prepare gangplank for safe loading referring to the below table and illustration.

A	B
1.0	3.65 ~ 3.85
1.1	4.00 ~ 4.25
1.2	4.35 ~ 4.60
1.3	4.75 ~ 5.00
1.4	5.10 ~ 5.40
1.5	5.50 ~ 5.75

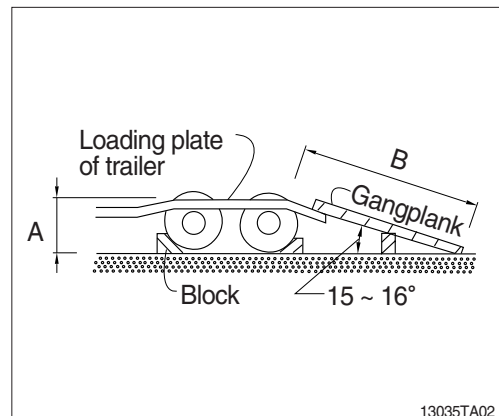
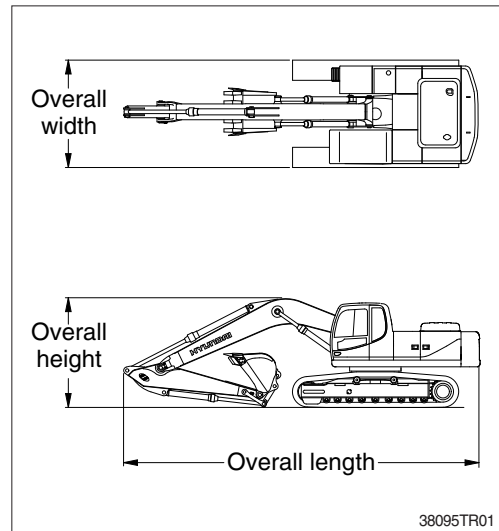

## 6. ADJUSTABLE TRACK GAUGE

### 1) LOWER TRACK RETRACTION

▲ Do not retract the track gauge except transporting purpose.

(1) Remove 12 bolts (1), and spacers from lower track(2) to the retracted.

※ Do not loosen two bolts (3) on guide (4).

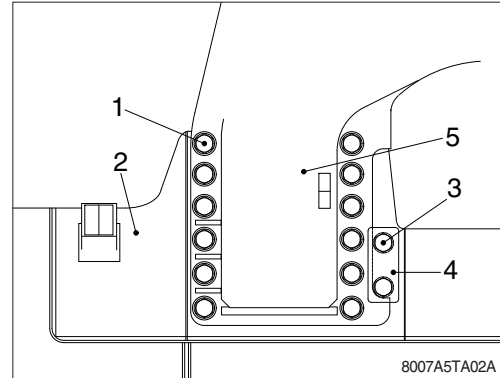

(2) Turn superstructure so that it is perpendicular to lower track to be retracted. Raise lower track to approximately 15 degree from ground using a jack. Lower track should slide by its own weight and hit against the stop.

※ If lower track does not slide in this condition, allow lower track that is not contraction ground to move back and forth slowly.

▲ The arm must be set at 90~110 degree.  
Never set it at an angle less than 90 degree.

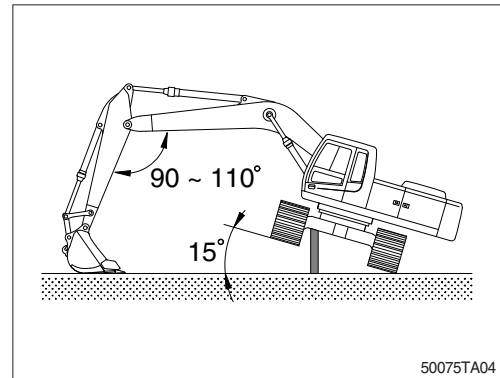

(3) After lower track (2) has slid into place, lower superstructure to ground.

Install 6 spacers and bolts (1).

※ Tighten bolts to  $280 \pm 30 \text{ kgf} \cdot \text{m}$  ( $2020 \pm 220 \text{ lbf} \cdot \text{ft}$ )

※ Repeat procedure at opposite side center frame support.

(4) After the bolts for one side frame are fastened, repeat steps 1 thru 3 for opposite side frame.

(5) Store remaining bolts, spacers with machine.

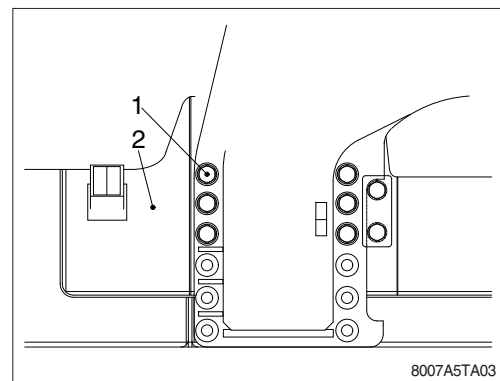

### 3. FUEL, COOLANT AND LUBRICANTS

#### 1) NEW MACHINE

New machine used and filled with following lubricants.

Description	Specification
Engine oil	SAE 10W-30 (API CH-4), ★SAE 5W-30 (API CH-4)
Hydraulic oil	Hyundai genuine long life hydraulic oil (ISO VG 46, VG 68) Conventional hydraulic oil (ISO VG 15★)
Swing and travel reduction gear	SAE 80W-90 (API GL-5)
Grease	Lithium base grease NLGI No. 2
Fuel	ASTM D975-No. 2
Coolant	Mixture of 50% ethylene glycol base antifreeze and 50% water. Mixture of 60% ethylene glycol base antifreeze and 40% water. ★

**SAE** : Society of Automotive Engineers

★ Cold region

**API** : American Petroleum Institute

Russia, CIS, Mongolia

**ISO** : International Organization for Standardization

**NLGI** : National Lubricating Grease Institute

**ASTM** : American Society of Testing and Material

- (5) Operate the engine at low idle and inspect for leaks at the filters and the drain plug.  
Shut the engine off and check the oil level with the dipstick. Allow 15 minutes for oil to drain down before checking.

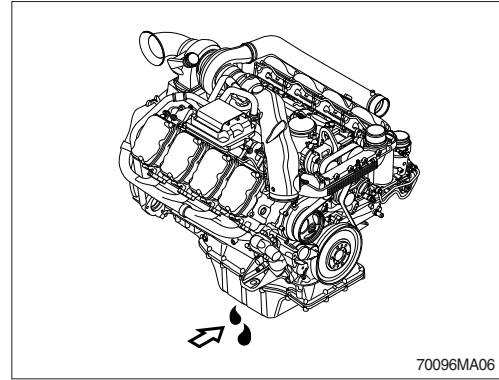

### 3) CLEANING THE CENTRIFUGAL OIL CLEANER

※ When cleaning the centrifugal oil cleaner there will be some dirt deposits in the rotor cover. If this is the case, this indicates that the rotor is working. If it is not working, the cause must be established immediately.

If the dirt deposit exceeds 28 mm at the recommended intervals, the rotor cover should be cleaned more often.

▲ The oil may be hot. Carefully remove the cover from the centrifugal oil cleaner.

- (1) Clean the outside of the cover.  
Unscrew the nut and remove the cover.
- (2) Lift out the rotor.  
Wipe off the outside of the rotor.  
Unscrew the rotor cover nut about one and a half turns.

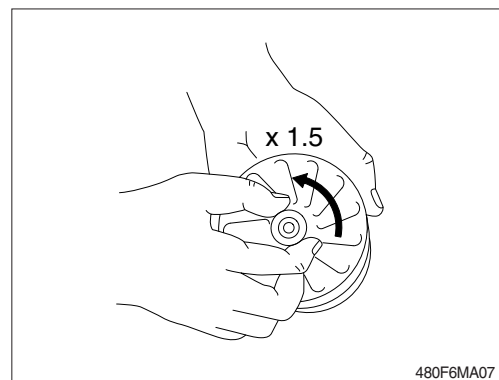
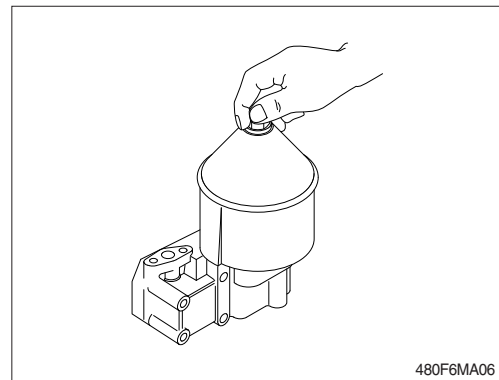

- (3) If the rotor nut is jammed, turn the rotor upside down and fasten the nut in a vice.  
Turn the rotor approximately one and a half turns anticlockwise by hand or use an M20 screw as illustrated.

※ The rotor must not be put in a vice. This may cause damage resulting in rotor imbalance.

- (4) Hold the rotor and tap lightly on the rotor nut with a plastic mallet or against the workbench, so that the rotor cover comes loose from the bottom plate.

※ Never strike on the rotor directly as this may damage the bearings.

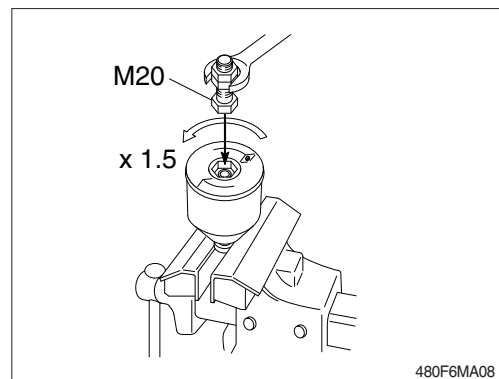

## 12) CLEANING OF AIR CLEANER

### (1) Primary element

- ① Open cover and remove the element.
  - ② Clean the inside of the body.
  - ③ Clean the element with pressurized air.
    - Remove the dust inside of the element by the pressurized air (below 3 kgf/cm<sup>2</sup>, 40 psi) forward and backward equally.
  - ④ Inspect for cracks or damage of element by putting a light bulb inside of the element.
  - ⑤ Insert element and tighten wing nut.
- ※ **Replace the primary element after 4 times cleanings.**

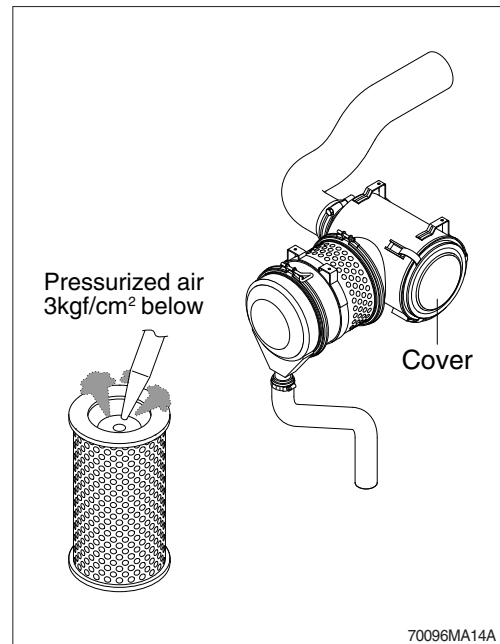

### (2) Safety element

- ※ **Replace the safety element only when the primary element is cleaned for the 4 times.**
- ※ **Always replace the safety element. Never attempt to reuse the safety element by cleaning the element.**

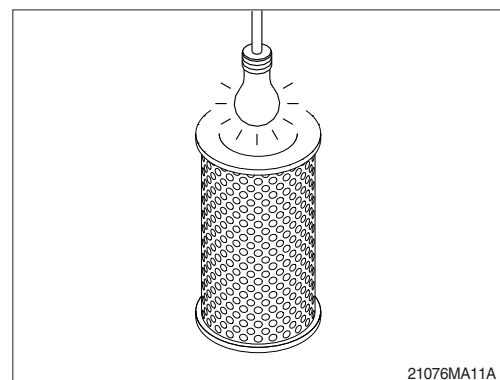

## 13) CLEANING OF AIR COMPRESSOR FILTER

- (1) Open cover and remove the element.
  - (2) Clean the element with pressurized air.
- ※ **Do not wash the element with water.**

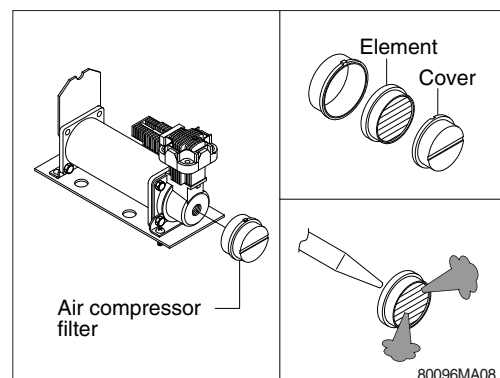

### 35) ADJUSTMENT OF TRACK TENSION

- ※ It is important to adjust the tension of track properly to extend the lifetime of track and traveling device.
- ※ The wear of pins and bushings on the undercarriage will vary with the working conditions and soil properties.

It is thus necessary to continually inspect the track tension so as to maintain the standard tension on it.

- (1) Raise the chassis with the boom and arm.
  - (2) Measure the distance between bottom of track frame on track center and track of shoe.
- ※ **Remove mud with rotating the track before measuring.**

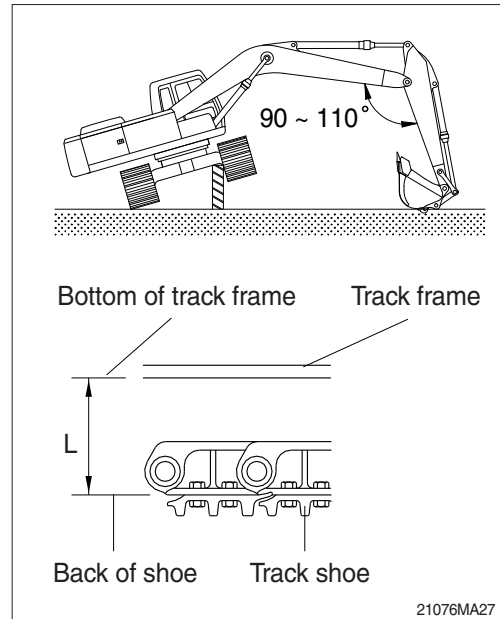

- (3) If the tension is tight, drain the grease in the grease nipple and if the tension is loose, charge the grease.

**▲ Personal injury or death can result from grease under pressure.**

**▲ When loosening the grease nipple, do not loosen more than one turn as there is a danger of a spring coming out of the nipple because of the high pressure inside.**

- ※ When the grease is drained, move the track to the forward and backward slightly.

If the track tension is loose even after the grease is charged to the maximum, change the pins and bushings as there are worn seriously.

Working condition	Length (L)	
	General	400~430 mm
Swamp	430~460 mm	16.9~18.1"
Sand, Mud, Pebbles	About 460 mm	About 18.1"

# TROUBLESHOOTING GUIDE

## 1. ENGINE

※ This guide is not intended to cover every conditions, however many of the more common possibilities are listed.

Trouble	Service	Remark
The engine oil pressure lamp lights ON when engine speed is raised after completion of warm up.	<ul style="list-style-type: none"> <li>· Add the oil to the specified level.</li> <li>· Replace the oil filter cartridge.</li> <li>· Check oil leakage from the pipe or the joint.</li> <li>· Replace the monitor.</li> </ul>	
Steam is emitted from the top part of the radiator (the pressure valve). Coolant level warning lamp lights ON.	<ul style="list-style-type: none"> <li>· Supply the coolant and check leakage.</li> <li>· Adjust fan belt tension.</li> <li>· Wash out inside of cooling system.</li> <li>· Clean or repair the radiator fin.</li> <li>· Check the thermostat.</li> <li>· Tighten the radiator cap firmly or replace the packing of it.</li> <li>· Replace the monitor.</li> </ul>	
The engine does not start when the starting motor is turned over.	<ul style="list-style-type: none"> <li>· Add fuel.</li> <li>· Repair where air is leaking into fuel system.</li> <li>· Check the injection pump or the nozzle.</li> <li>· Check the valve clearance.</li> <li>· Check engine compression pressure.</li> </ul>	
Exhaust gas is white or blue.	<ul style="list-style-type: none"> <li>· Adjust to specified oil quantity.</li> <li>· Replace with specified fuel.</li> </ul>	
Exhaust gas occasionally turns black.	<ul style="list-style-type: none"> <li>· Clean or replace the air cleaner element.</li> <li>· Check the nozzle.</li> <li>· Check engine compression pressure.</li> <li>· Clean or replace the turbocharger.</li> </ul>	
Combustion noise occasionally changes to breathing sound.	<ul style="list-style-type: none"> <li>· Check the nozzle.</li> </ul>	
Unusual combustion noise or mechanical noise.	<ul style="list-style-type: none"> <li>· Check with specified fuel.</li> <li>· Check over-heating.</li> <li>· Replace the muffler.</li> <li>· Adjust valve clearance.</li> </ul>	

## 1. CENTRAL GREASE LUBRICATION SYSTEM

### 1) MAJOR COMPONENT

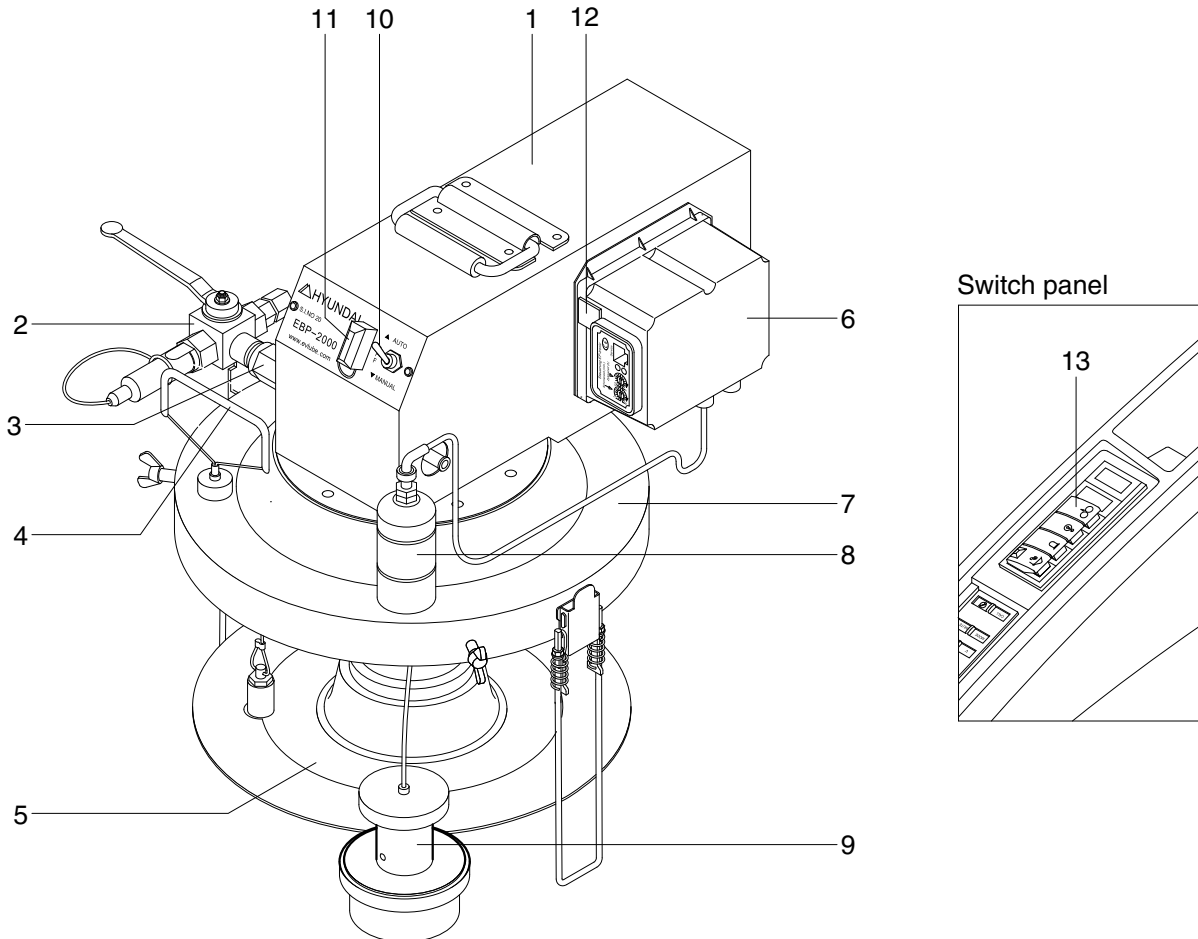

- |                                |   |   |
|--------------------------------|---|---|
| 1 Pump cover assy              | 6 Controller assy                           | 10 Toggle switch  |
| 2 3-way valve assy             | 7 Main plate assy                           | 11 Fuse   |
| 3 Inline check and air vent    | 8 Low level sensor and level indicator assy | 12 Reset switch   |
| 4 Follow plate air vent handle | 9 Cylinder assy and piston assy             | 13 Central grease lubrication switch (refer to the page 3-27) |
| 5 Follow plate assy            |   |   |

900L8AG100

#### (4) Exchange grease canister

※ Exchange of grease canister is a following procedure.

- ① Replace toggle switch to OFF and disconnect power cable.
- ② Unfasten wing bolts (3EA).

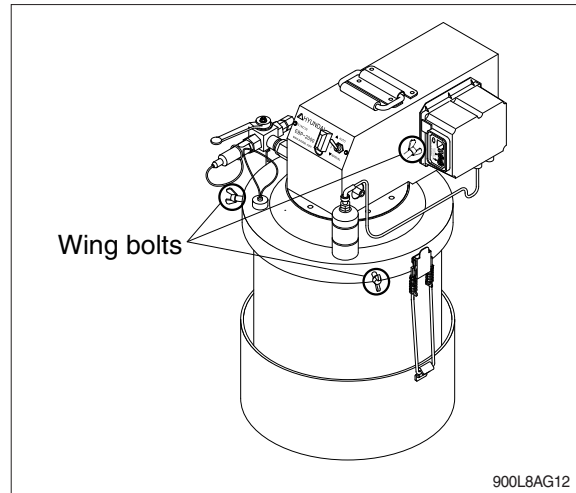

- ③ Unlock the clamp and loosen the clamp leg.
- ④ Pull air vent handle of following plate up.
- ⑤ Remove grease pump from grease canister.

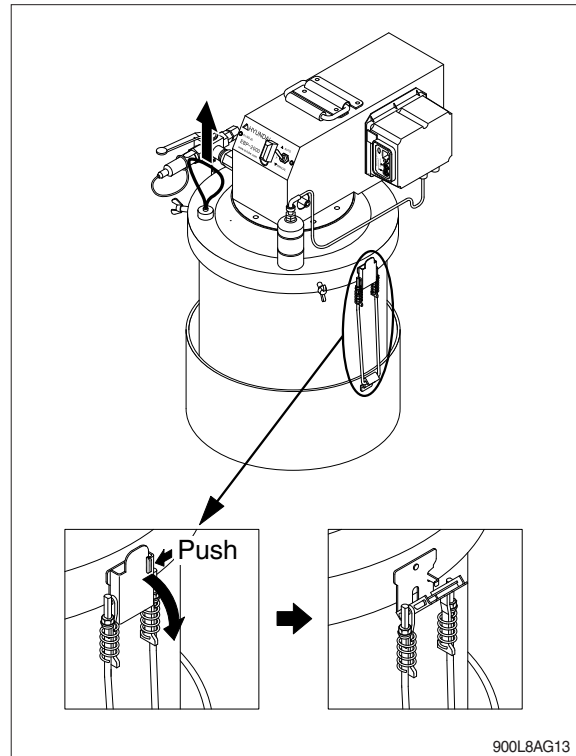

- ⑥ Remove grease canister and fix new grease canister.

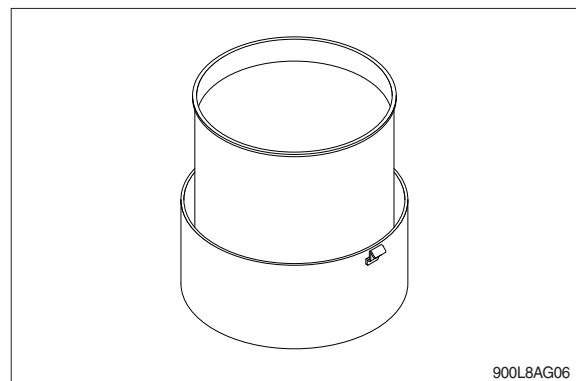

#### (4) Inspection of main lube line at main distributor

- ① Disconnect connector using a 17 mm spanner.

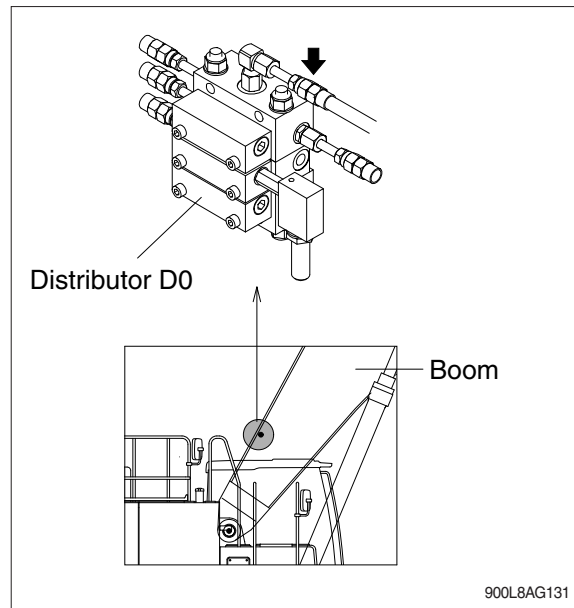

- ② Place toggle switch to AUTO mode and push reset switch.



- ③ Check grease come out.

※ **Although pump run, but there is no grease come out.**

- Blocked main lube line -> Exchange main lube line
- Check 3-way valve direction (Refer to page 9-17, ② Exchange AUTO mode.)
- Pump out of order -> Refer to page 9-27, 3 of (1) Pump.

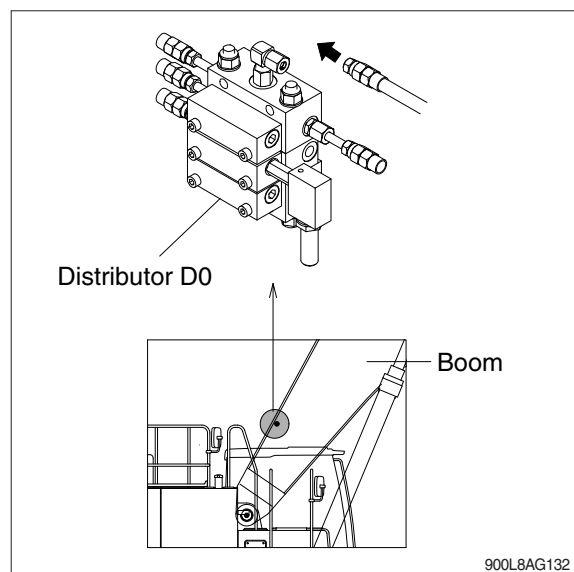

CLICK HERE TO **DOWNLOAD** THE COMPLETE MANUAL

- Thank you very much for reading the preview of the manual.
- You can download the complete manual from: [www.heydownloads.com](http://www.heydownloads.com) by clicking the link below



- Please note: If there is no response to CLICKING the link, please download this PDF first and then click on it.

CLICK HERE TO **DOWNLOAD** THE COMPLETE MANUAL