

CONTENTS

Foreword	0-1	6. Traveling of the machine	4-13		
Before servicing this machine	0-2	7. Efficient working method	4-16		
Table to enter S/No and distribution	0-3	8. Operation in the special work sites	4-20		
Safety labels	0-4	9. Normal operation of excavator	4-22		
Machine data plate	0-19	10. Attachment lowering	4-23		
Guide (direction, S/No, symbol)	0-20	11. Storage	4-24		
		12. RCV lever operating pattern	4-26		
SAFETY HINTS					
1. Before operating the machine	1-1	TRANSPORTATION			
2. During operating the machine	1-15	1. Preparation for transportation	5-1		
3. During maintenance	1-22	2. Dimension and weight	5-2		
4. Parking	1-25	3. Loading the machine	5-4		
		4. Fixing the machine	5-6		
SPECIFICATIONS				5. Loading and unloading by crane	5-7
1. Major components	2-1	MAINTENANCE			
2. Specifications	2-2	1. Instruction	6-1		
3. Working range	2-4	2. Tightening torque	6-6		
4. Weight	2-5	3. Fuel, coolant and lubricants	6-9		
5. Lifting capacities	2-6	4. Maintenance check list	6-11		
6. Bucket selection guide	2-11	5. Maintenance chart	6-16		
7. Undercarriage	2-13	6. Service instruction	6-18		
8. Specification for major components	2-15	7. Electrical system	6-44		
9. Recommended oils	2-18	8. Air conditioner and heater	6-47		
CONTROL DEVICES				TROUBLESHOOTING GUIDE	
1. Cab devices	3-1	1. Engine	7-1		
2. Cluster	3-2	2. Electrical system	7-2		
3. Switches	3-33	3. Others	7-3		
4. Levers and pedals	3-37	HYDRAULIC BREAKER AND QUICK CLAMP			
5. Air conditioner and heater	3-39	1. Selecting hydraulic breaker	8-1		
6. Others	3-43	2. Circuit configuration	8-2		
OPERATION				3. Maintenance	8-3
1. Suggestion for new machine	4-1	4. Precaution while operating the breaker	8-4		
2. Check before starting the engine	4-2	5. Quick clamp	8-6		
3. Starting and stop the engine	4-3	INDEX		9-1	
4. Mode selection system	4-7				
5. Operation of the working device	4-12				

CLICK HERE TO **DOWNLOAD** THE COMPLETE MANUAL

- Thank you very much for reading the preview of the manual.
- You can download the complete manual from: www.heydownloads.com by clicking the link below



- Please note: If there is no response to CLICKING the link, please download this PDF first and then click on it.

CLICK HERE TO **DOWNLOAD** THE COMPLETE MANUAL

20) SAFETY REAR WINDOW (item 23)

This warning label is positioned on the rear side window of the cab.

- ※ The rear window serves as an alternate exit.
- ※ To remove rear window, pull the ring and push out the glass.



2609A0SL02

21) AIR CONDITIONER FILTER (item 24)

This warning label is positioned on the air conditioner cover.

- ※ Periodic and proper inspection, cleaning and change of filter prolong air conditioner life time and maintain good performance.

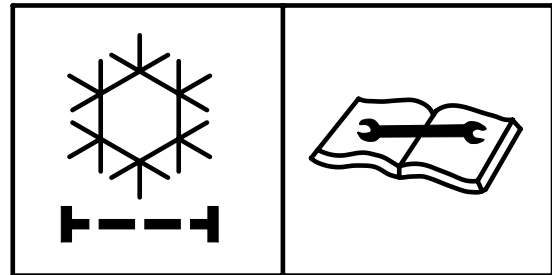

21070FW26

22) SAFETY LEVER (item 26)

This warning label is positioned on the cover of the safety lever.

- ▲ Before you get off the machine be sure to place the safety lever LOCKED position.

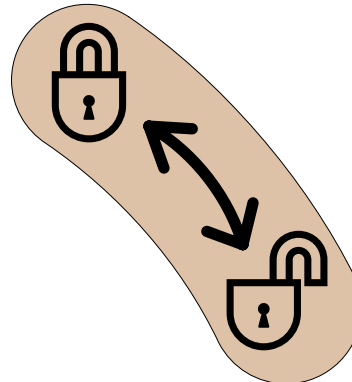

30007A1FW07A

23) REDUCTION GEAR GREASE (item 31)

This warning label is positioned on the front side of upper frame.

- ▲ Grease is under high pressure. Grease coming out of the grease plug under pressure can penetrate the body causing injury or death.

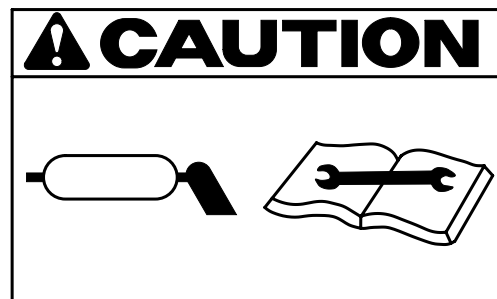

21070FW35

SAFETY HINTS

1. BEFORE OPERATING THE MACHINE

Think-safety first.

In special situation, wear protective clothing including a safety helmet, safety shoes, gloves, safety glasses and ear protection as required by the job condition.

Almost every accident is caused by disregarding the simple and fundamental safety hints.

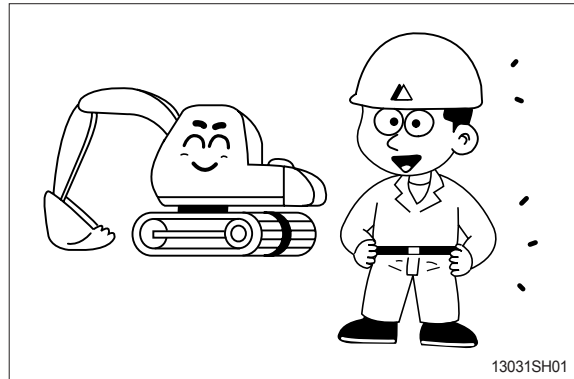

Be sure to understand thoroughly all about the operator's manual before operating the machine.

Proper care is your responsibility.

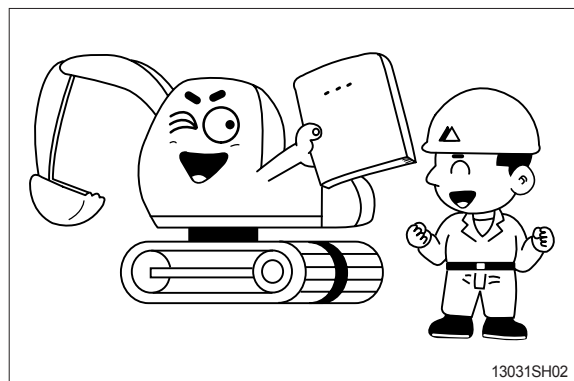

Fully understand the details and process of the construction before starting the work.

If you find anything dangerous on the job, consult with the job supervisor for the preventive measures before operating the machine.

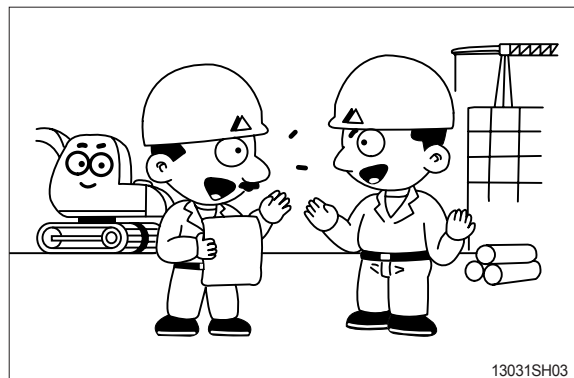

Do not operate when tired, or after drinking alcoholic beverages or any type of drugs.

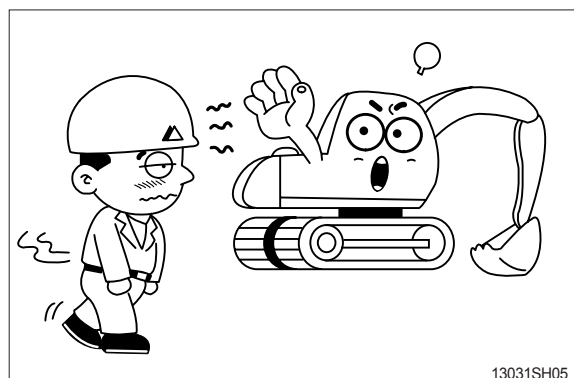

Fire extinguisher Location

Make sure that a fire extinguisher is available. Be familiar with the operation of the fire extinguisher. Inspect the fire extinguisher and service the fire extinguisher. Obey the recommendations on the instruction plate.

Mount the fire extinguisher in the accepted location per local regulations.

If your machine is equipped with a ROPS structure, strap the mounting plate to the ROPS in order to mount the fire extinguisher. If the weight of the fire extinguisher exceeds 4.5 kg (10 lb), mount the fire extinguisher near the bottom of the ROPS. Do not mount the fire extinguisher at the upper one-third area on the ROPS.

Do not weld the ROPS structure in order to install the fire extinguisher. Also, do not drill holes in the ROPS structure in order to mount the fire extinguisher on the ROPS.

Consult your HD Hyundai dealer for the proper procedure for mounting the fire extinguisher.

This machine has ROPS / FOG with option.
Do not attempt to repair a rollover protective structure (ROPS) after an accident.
Repaired structures do not provide the original structure and protection.
Test and approved as a protective CAB according to ROPS and FOG standard.
Meets : ISO 10262 / 3449 / 12117-2
SAE J1356 / JISO 3449

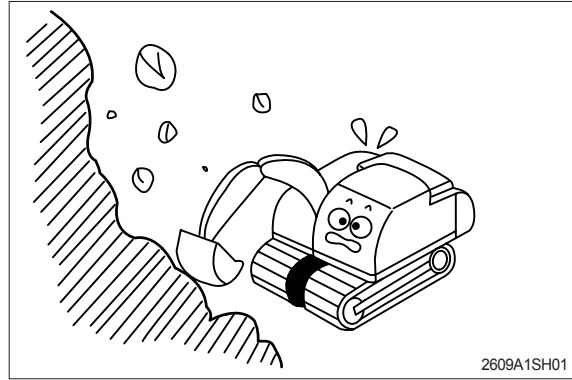

MOUNTING AND DISMOUNTING

Never jump on or off the machine. **Never** get on or off a moving machine.

When mounting or dismounting, always face the machine and use the handrails, machine or track frame steps, and track shoes. Additional track frame step can be fitted for wider optional shoe. In this case please contact your HD Hyundai distributor.

Do not hold any control levers when getting on or off the machine.

Ensure safety by always maintaining at least three-point contact of hands and feet with the handrails, steps or track shoes.

Always remove any oil or mud from the handrails, steps and track shoes. If they are damaged, repair them and tighten any loose bolts.

If grasping the door handrail when mounting or dismounting or moving on the track, open and lock the door securely in the open position. Otherwise, the door may move suddenly, causing you to lose balance and fall.

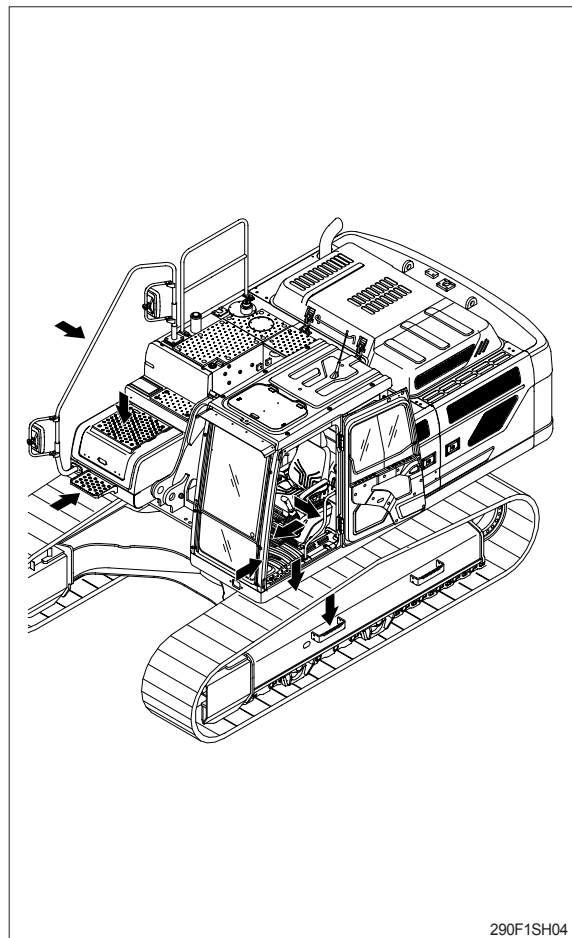

KEEP RIDERS OFF MACHINE

Riders on a machine are subject to injury such as being struck objects and being thrown off the machine.

Only allow the operator on the machine. Keep riders off.

2) 6.45m (21'2") boom, 3.2m (10'4") arm equipped with 600mm (24") triple grouser shoe and 6,600 kg (13230 lb) counterweight



Rating over-front



Rating over-side or 360 degree

Load Point Height		Load Radius										At max. reach				
		3.0m (9.8 ft)		4.5 m (14.8 ft)		6.0m (19.7 ft)		7.5m (24.6 ft)		9.0 (29.5 ft)		Capacity		Reach		
														m (ft)		
7.5m	Kg							*6300	*6300					*4910	*4910	7.88
24.6ft	lb							*13890	*13890					*10820	*10820	(25.9)
6.0m	Kg							*6530	*6530					*4850	*4850	8.75
19.7ft	lb							*14400	*14400					*10690	*10690	(28.7)
4.5m	Kg					*8150	*8150	*7200	6290	*6570	4500			*4990	4230	9.28
14.8ft	lb					*17970	*17970	*15870	13870	*14480	9920			*11000	9330	(30.5)
3.0m	Kg			*13430	*13430	*9830	8560	*8100	5960	6840	4330			*5320	3870	9.56
9.8ft	lb			*29610	*29610	*21670	18870	*17860	13140	15080	9550			*11730	8530	(31.4)
1.5m	Kg			*16300	12370	*11410	7990	8970	5640	6660	4170			*5870	3730	9.58
4.9ft	lb			*35940	27270	*25150	17610	19780	12430	14680	9190			*12940	8220	(31.4)
Ground line	Kg	*8690	*8690	*17710	11820	12470	7600	8710	5400	6520	4040			6120	3780	9.37
Ground line	lb	*19160	*19160	*39040	26060	27490	16760	19200	11900	14370	8910			13490	8330	(30.7)
-1.5m	Kg	*13540	*13540	*17870	11670	12260	7420	8570	5280					6590	4070	8.89
-4.9ft	lb	*29850	*29850	*39400	25730	27030	16360	18890	11640					14530	8970	(29.2)
-3.0m	Kg	*19290	*19290	*17020	11760	12260	7430	8580	5290					7620	4720	8.11
-9.8ft	lb	*42530	*42530	*37520	25930	27030	16380	18920	11660					16800	10410	(26.6)
-4.5m	Kg	*21120	*21120	*15000	12050	*11130	7620							*9200	6170	6.92
-14.8ft	lb	*46560	*46560	*33070	26570	*24540	16800							*20280	13600	(22.7)
-6.0m	Kg			*10840	*10840									*9590	*9590	5.01
-19.7ft	lb			*23900	*23900									*21140	*21140	(16.4)

- NOTES :
1. Lifting Capacity are based on SAE J1097, ISO 10567.
 2. Lifting Capacity of the Robex Series does not exceed 75% of tipping load with the machine on firm, level ground or 87% of full hydraulic capacity.
 3. The load point is a hook (standard equipment) located on the back of the bucket.
 4. (*) Indicates load limited by hydraulic capacity.

Load Point Height		Load Radius										At max. reach				
		3.0m (9.8 ft)		4.5 m (14.8 ft)		6.0m (19.7 ft)		7.5m (24.6 ft)		9.0 (29.5 ft)		Capacity		Reach		
														m (ft)		
7.5m	Kg							*7750	7210					*6630	*6630	7.74
24.6ft	lb							*17090	15900					*14620	*14620	(25.4)
6.0m	Kg							*7860	7140					*6420	5620	8.62
19.7ft	lb							*17330	15740					*14150	12390	(28.3)
4.5m	Kg			*11980	*11980	*9650	*9650	*8500	6930	7650	5150			*6450	4990	9.17
14.8ft	lb			*26410	*26410	*21270	*21270	*18740	15280	16870	11350			*14220	11000	(30.1)
3.0m	Kg			*15520	14090	*11340	9250	*9380	6660	7520	5030			*6690	4660	9.44
9.8ft	lb			*34220	31060	*25000	20390	*20680	14680	16580	11090			*14750	10270	(31.0)
1.5m	Kg			*18140	13210	*12840	8770	9710	6400	7390	4910			6840	4540	9.47
4.9ft	lb			*39990	29120	*28310	19330	21410	14110	16290	10820			15080	10010	(31.1)
Ground line	Kg			*19100	12840	13340	8470	9510	6210	7290	4820			7010	4630	9.25
Ground line	lb			*42110	28310	29410	18670	20970	13690	16070	10630			15450	10210	(30.4)
-1.5m	Kg	*12280	*12280	*18880	12780	13200	8360	9420	6130					7540	4970	8.77
-4.9ft	lb	*27070	*27070	*41620	28180	29100	18430	20770	13510					16620	10960	(28.8)
-3.0m	Kg	*19800	*19800	*17670	12910	13250	8400	9470	6180					8700	5710	7.98
-9.8ft	lb	*43650	*43650	*38960	28460	29210	18520	20880	13620					19180	12590	(26.2)
-4.5m	Kg	*20570	*20570	*15170	13220	*11400	8620							*9590	7350	6.76
-14.8ft	lb	*45350	*45350	*33440	29150	*25130	19000							*21140	16200	(22.2)
-6.0m	Kg															
-19.7ft	lb															

- NOTES :
1. Lifting Capacity are based on SAE J1097, ISO 10567.
 2. Lifting Capacity of the Robex Series does not exceed 75% of tipping load with the machine on firm, level ground or 87% of full hydraulic capacity.
 3. The load point is a hook (standard equipment) located on the back of the bucket.
 4. (*) Indicates load limited by hydraulic capacity.

2. CLUSTER

1) STRUCTURE

The cluster consists of LCD and switches as shown below. The LCD is to warn the operator in case of abnormal machine operation or conditions for the appropriate operation and inspection. Also, The LCD is to set and display for modes, monitoring and utilities with the switches.

The switches or touch screen are to set the machine operation modes.

- ※ The cluster installed on this machine does not entirely guarantee the condition of the machine. Daily inspection should be performed according to chapter 6, Maintenance.
- ※ When the cluster provides a warning immediately check the problem, and perform the required action.

Normal type



220S3CD501

Premium type



220S3CD01

- ※ The warning lamp pops up and/or blinks and the buzzer sounds when the machine has a problem. The warning lamp blinks until the problem is cleared. Refer to page 3-6 for details.

5) SWITCHES

Normal type



220S3CD586

Premium type



220S3CD86

※ When some of the switches are selected, the pilot lamps are displayed on the LCD. Refer to the page 3-9 for details.

(3) Monitoring

① Active fault

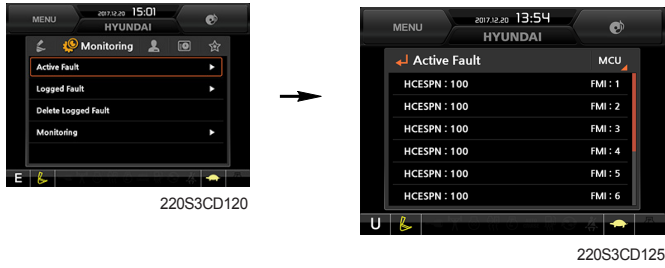

- The active faults of the MCU can be checked by this menu.

② Logged fault

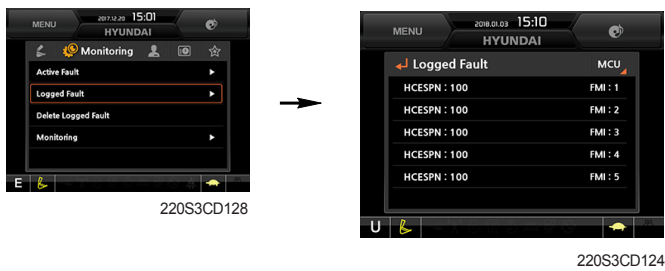

- The logged faults of the MCU can be checked by this menu.

③ Delete logged fault



- The logged faults of the MCU can be deleted by this menu.

④ Monitoring

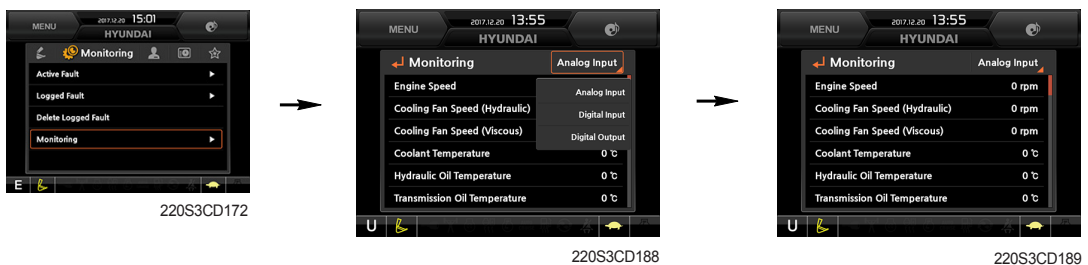

- The machine status such as the engine rpm, oil temperature, voltage and pressure etc. can be checked by this menu (Analog input).
- The switch status or output status can be confirmed by this menu (Digital input & Digital output).
- The activated switch or output pilot lamps ● are light ON.

④ AAVM (All Around View Monitoring, premium type, opt)

- The AAVM buttons of the cluster consist of ESC/CAM and AUTO IDLE/Buzzer stop.



220S3CD244

- Escape button

- It will enter into the AAVM mode from the beginning screen if the AAVM is installed.
- While in the AAVM mode, select the ESC button to return to the beginning screen.



220S3CD156

The beginning screen

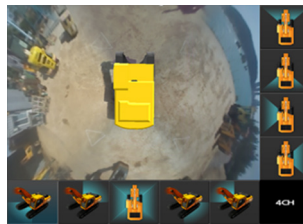

AAVM mode

290F3CD222

- Buzzer stop button

- In AAVM mode, it detects surrounding pedestrians or objects and the warning buzzer sounds.
- User can turn OFF the warning sound by pressing buzzer stop button.



290F3CD246

- When the worker or pedestrian go to the blue line (radius 5 m), an external danger area of equipping on the cluster screen, the warning buzzer sounds and it displays the blue rectangular box for the recognition of the worker and pedestrian. At this time, the operator should stop work immediately, and stop the buzzer by pressing the buzzer stop button. And then, please work after you check whether the danger factors are solved.



290F3CD247

- When the worker or pedestrian go inside of red line (radius 3 m), an internal danger area of equipping on the cluster screen, the warning buzzer sounds and it displays the red rectangular box for the recognition of the worker and pedestrian. At this time, the operator should stop work immediately, and stop the buzzer by pressing the buzzer stop button. And then, please work after you check whether the danger factors are solved.

※ In AAVM mode, a touch screen of the LCD is available only. The multimodal dial of the haptic controller is not available.

CLICK HERE TO **DOWNLOAD** THE COMPLETE MANUAL

- Thank you very much for reading the preview of the manual.
- You can download the complete manual from: www.heydownloads.com by clicking the link below



- Please note: If there is no response to CLICKING the link, please download this PDF first and then click on it.

CLICK HERE TO **DOWNLOAD** THE COMPLETE MANUAL

8) SELF DIAGNOSIS FUNCTION

(1) Procedure

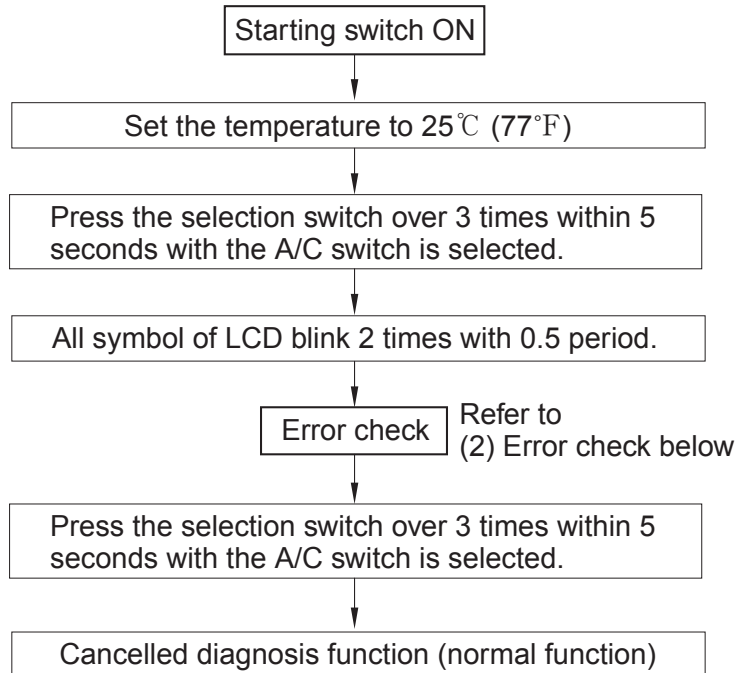

220S3CD59

(2) Error check

- If normal, display E0.
- The corresponding error code flickers on the setup temperature display panel, the other symbol will turn OFF.
- Error code flickers every 0.5 second.
- If error code is more than two, each code flickers 2 times in sequence.
- Up and down the error codes by pressing the temperature control switch.
- Error code

Error code	Description	Error code	Description
E0	Normal	E5	Duct sensor short
E1	Incar sensor short	E6	Duct sensor open
E2	Incar sensor open	E11	DPS open
E3	Ambient sensor short	E12	Mode actuator fail
E4	Ambient sensor open	E13	Mix actuator fail

■ BLUETOOTH

(1) Introduce

The bluetooth radio supports bluetooth wireless technology. Bluetooth technology provides a wire-less link between a bluetooth mobile phone or bluetooth music player and the HD Hyundai bluetooth radio.

The bluetooth radio features a hands-free system so that you may talk on the telephone without taking your eyes off the road or your hands off the wheel. A microphone built into the front of the radio receives your voice and the calling party can be heard through the speakers.

Additionally, a bluetooth music player can be wirelessly connected to be the bluetooth radio and playback music tracks in high quality sound through the speakers. Many bluetooth mobile phones include a music player and can provide both hands-free calling and music playback.

Check your mobile phone owner's manual for details.

- ※ When the starting switch is in the ON position, the bluetooth radio is on standby to connect with your mobile phone even if the radio is switched off. The machine battery may therefore become drained if the ignition switch remains in the ON position for an extended period of time.
- ※ Bluetooth technology uses low power radio transmission to connect to your bluetooth mobile phone or bluetooth music player. As radio signal strength reduces over distance, the quality of sound performance during phone calls and music playback may become poor if the distance between the radio and device widens. It is recommended that the mobile phone or music player is kept inside the cab for best results.
- ※ As a bluetooth wireless connection can extend to 10 meters, your bluetooth device may automatically connect to the bluetooth radio even if the device is not in the machine.
- ※ The bluetooth radio uses the latest digital noise & echo suppression system to provide the best sound clarity with little or no distortion, but in some conditions there may be some echo and noise experienced. It is recommended to keep the car windows closed during hands-free calls for best results.

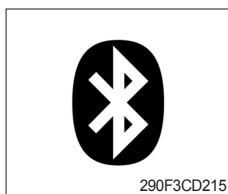

① Bluetooth indicator

The bluetooth logo is displayed when a bluetooth device is connected, and not displayed, when no bluetooth device is connected. If the bluetooth mobile phone is connected but the connection is not of satisfactory quality, the bluetooth logo is not displayed.

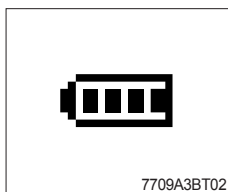

② Battery strength indicator

This is an indication of your mobile phone battery condition. If your mobile phone is unable to transmit battery condition level, the indicator is not displayed.



③ Single level indicator

This is an indication of the mobile phone network signal strength in your current location. If your mobile phone is not able to transmit signal level, the indicator is not displayed.

(6) Monitoring system

Information of machine performance as monitored by the MCU can be displayed on the LCD. Refer to the page 3-22.

(7) Self diagnostic system

① MCU (Machine Control Unit)

The MCU diagnoses machine status and problems and displays fault code in the cluster (fault code detected by MCU is composed of HCESPN and FMI).

※ Refer to the page 3-22 for LCD display.

(8) Anti-restart system

The system protects the starter from inadvertent restarting after the engine is already operational.

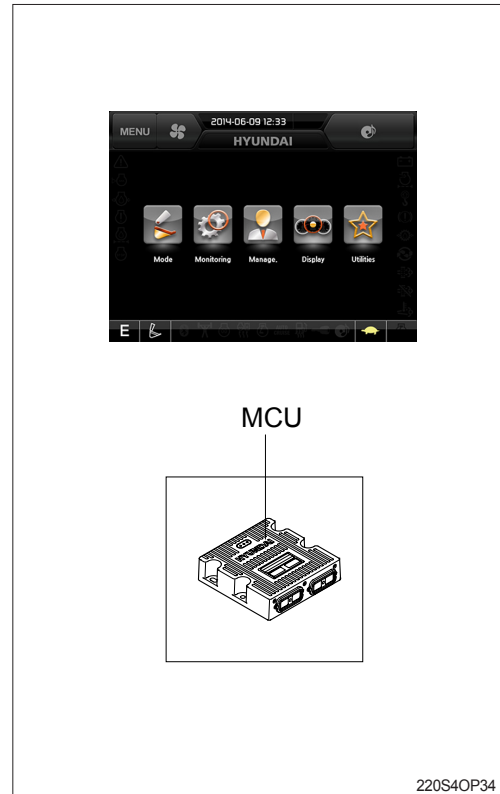

2) HOW TO OPERATE MODE SELECTION SYSTEM

(1) When start key switch is turned ON

- ① When start key switch is turned on, the cluster turns on and buzzer sounds for 4 seconds. And then main information as gauges and engine speed are displayed on LCD.
- ② Initial default mode settings are displayed in the cluster.

Mode		Status
Power mode	E	ON
Work mode		ON
Travel mode	Low (ON
Auto idle		ON

※ These setting can be changed at U mode.

- ③ Self-diagnostic function can be carried out from this point.

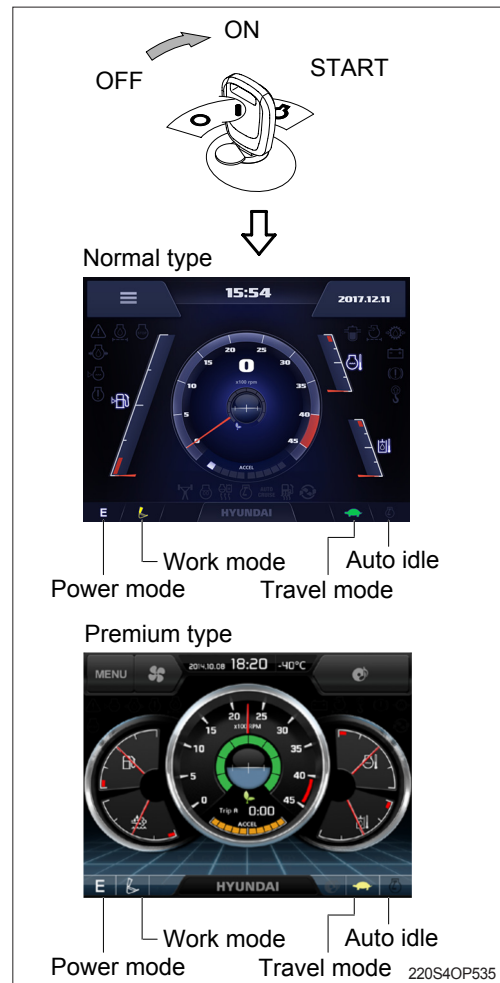

12) BUCKET WITH HOOK

When carrying out lifting work, the special lifting hook is necessary.

The following operations are prohibited.

- Lifting loads with a wire rope fitted around the bucket teeth.
- Lifting loads with the wire rope wrapped directly around the boom or arm.

When performing lifting operation, securely hook the wire rope onto the special lifting hook.

When performing lifting operation, never raise or lower a person.

Due to the possible danger of the load falling or of collision with the load, no persons shall be allowed in the working area.

Before performing lifting operation, designate an operation supervisor.

Always execute operation according to his instructions.

- Execute operating methods and procedures under his direction.
- Select a person responsible for signaling. Operate only on signals given by such person.

Never leave the operator's seat while lifting a load.

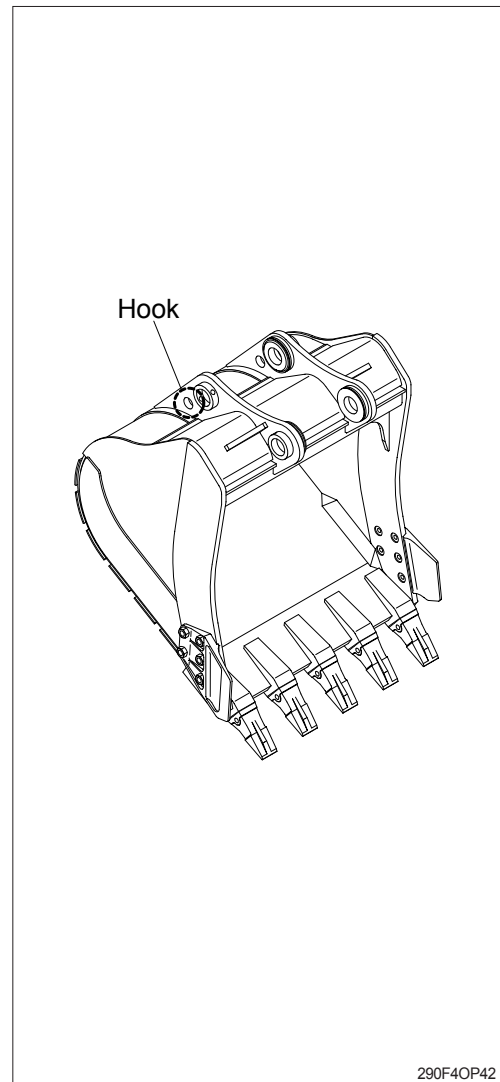

2. DIMENSION AND WEIGHT

1) HX380L

(1) Base machine

Mark	Description	Unit	Specification
L	Length	mm (ft-in)	5975 (19' 7")
H	Height	mm (ft-in)	3145 (10' 4")
W	Width	mm (ft-in)	3280 (10' 9")
Wt	Weight	kg (lb)	26785 (59051)

※ With 600 mm (24") triple grouser shoes and 6000 kg (13230 lb) counterweight.

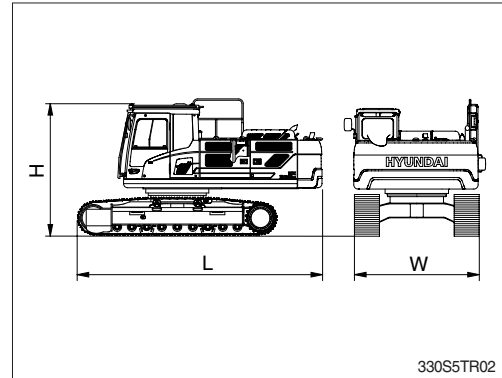

(2) Boom assembly

Mark	Description	Unit	Specification
L	Length	mm (ft-in)	6670 (21'11")
H	Height	mm (ft-in)	1720 (5' 8")
W	Width	mm (ft-in)	785 (2' 7")
Wt	Weight	kg (lb)	2940 (6482)

※ 6.45 m (21' 2") boom with arm cylinder (included piping and pins).

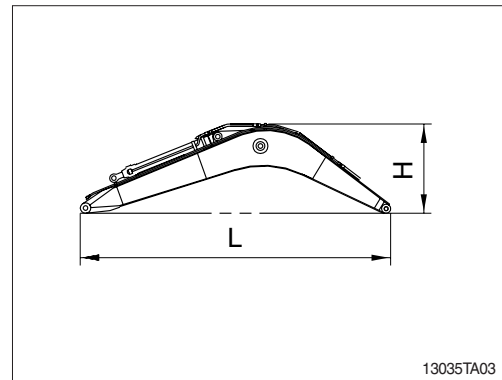

(3) Arm assembly

Mark	Description	Unit	Specification
L	Length	mm (ft-in)	4340 (14' 3")
H	Height	mm (ft-in)	955 (3' 2")
W	Width	mm (ft-in)	435 (1' 5")
Wt	Weight	kg (lb)	1435 (3163)

※ 3.2 m (10' 6") arm with bucket cylinder (included linkage and pins).

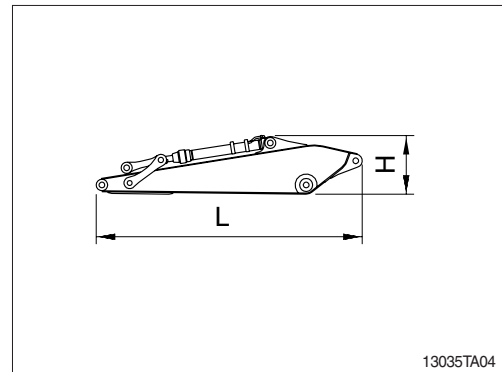

(4) Bucket assembly

Mark	Description	Unit	Specification
L	Length	mm (ft-in)	1840 (6' 0")
H	Height	mm (ft-in)	1120 (3' 8")
W	Width	mm (ft-in)	1535 (5' 0")
Wt	Weight	kg (lb)	1230 (2710)

※ 1.44 m³ (1.88 yd³) SAE heaped bucket (included tooth and side cutters).

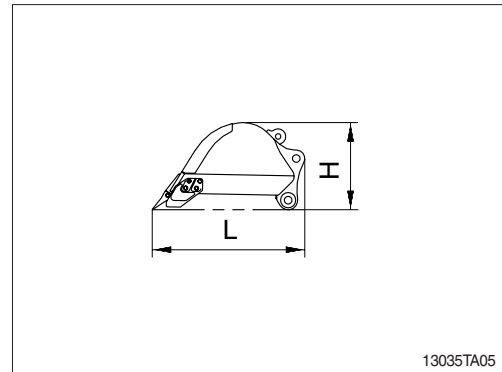

6) PERIODICAL REPLACEMENT OF SAFETY PARTS

(1) It is desirable to do periodic maintenance the machine for using the machine safely for a long time.

However, recommend to replace regularly the parts related safety not only safety but maintain satisfied performance.

(2) These parts can cause the disaster of life and material as the quality changes by passing time and it is worn, diluted, and gets fatigued by using repeatedly.

These are the parts which the operator can not judge the remained lifetime of them by visual inspection.

(3) Repair or replace if an abnormality of these parts is found even before the recommended replacement interval.

Periodical replacement of safety parts			Interval
Engine	Fuel hose (tank-engine)		Every 2 years
	Heater hose (heater-engine)		
Hydraulic system	Main circuit	Pump suction hose	Every 2 years
		Pump delivery hose	
		Swing hose	
	Working device	Boom cylinder line hose	Every 2 years
		Arm cylinder line hose	
		Bucket cylinder line hose	

※ 1. Replace O-ring and gasket at the same time when replacing the hose.

2. Replace clamp at the same time if the hose clamp is cracked when checking and replacing the hose.

11) WHEN REQUIRED

Whenever you have trouble in the machine, you must perform the service of related items, system by system.

Check items	Service	Page
Fuel system		
· Fuel tank	Drain or Clean	6-27
· Prefilter (water, element)	Drain or Replace	6-31
· Fuel filter element	Replace	6-28
Engine lubrication system		
· Engine oil	Change	6-18, 19
· Engine oil filter	Replace	6-18, 19
Engine cooling system		
· Coolant	Add or Change	6-20, 21, 22, 23
· Radiator	Clean or Flush	6-20, 21, 22, 23
· Charge air cooler	Check	6-23
Engine air system		
· Air cleaner element (primary)	Clean or Replace	6-27
· Air cleaner element (safety)	Replace	6-27
Hydraulic system		
· Hydraulic oil	Add or Change	6-34, 35
· Return filter	Replace	6-36
· Drain line filter	Replace	6-36
· Pilot line filter	Replace	6-37
· Element of breather	Replace	6-36
· Suction strainer	Clean	6-35
· RCV lever	Lubricate	6-39
Undercarriage		
· Track tension	Check, Adjust	6-39
Bucket		
· Tooth	Replace	6-41
· Side cutter	Replace	6-41
· Linkage	Adjust	6-40
· Bucket assy	Replace	6-40
Air conditioner and heater		
· Fresh air filter	Replace	6-47
· Recirculation filter	Clean, Replace	6-47, 48

9) BELT TENSIONER, AUTOMATIC Adjustment

- (1) Every 1000hours, or 1 year, whichever occurs first, inspect the automatic belt tensioner.

With the engine turned off, check that neither the top nor bottom tensioner arm stop is touching the cast boss on the tensioner body. If either of the stops is touching a boss, the alternator belt must be replaced. Check to make sure the correct belt part number is being used if either condition exists.

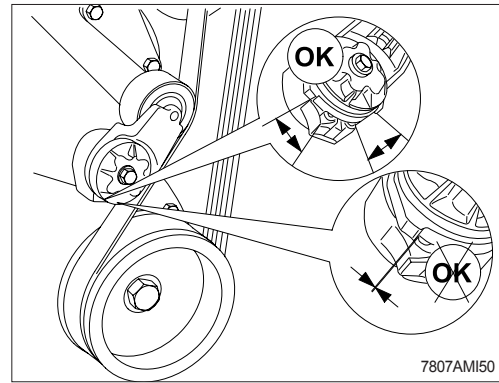

- (2) Check the tensioner pulley and body for cracks.

If any cracks are noticed, the tensioner must be replaced. Refer to a Cummins Authorized Repair facility. Check the tensioner for dirt buildup. If this condition exists, the tensioner must be removed and steam-cleaned.

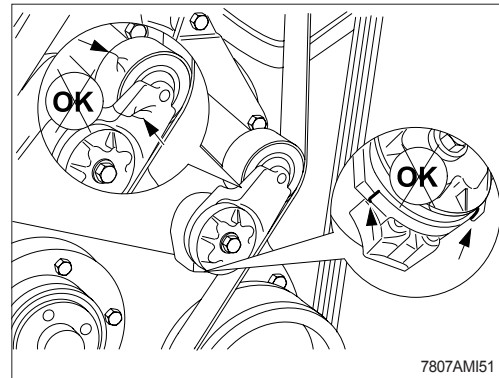

- (3) Check that the bottom tensioner arm stop is in contact with the bottom tensioner arm stop boss on the tensioner body. If these two are not touching, the tensioner must be replaced.

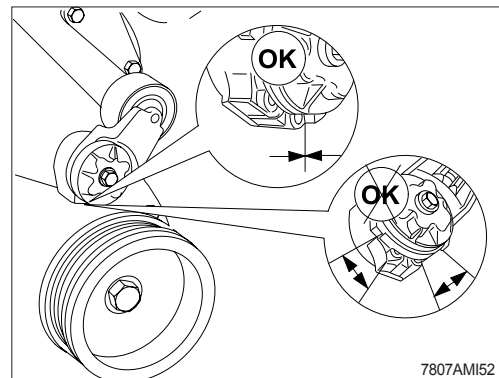

- (4) Inspect the tensioner for evidence of the pivoting tensioner arm contacting the stationary circular base. If there is evidence of these two areas touching, the pivot tube bushing has failed and the tensioner must be replaced.

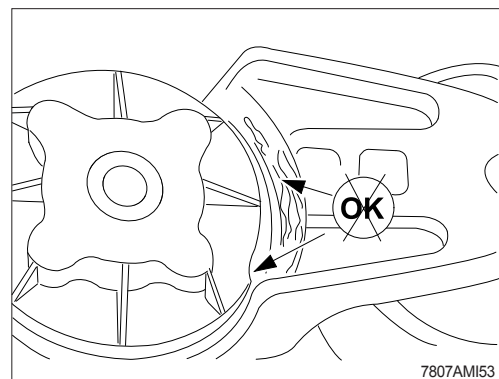

19) CHANGE HYDRAULIC OIL

- (1) Lower the bucket on the ground pulling the arm and bucket cylinder to the maximum.
- (2) Relieve the pressure in the tank by pushing the top of the air breather.
- (3) Remove the cover.
 - Tightening torque : $6.9 \pm 1.4 \text{ kgf} \cdot \text{m}$
($50 \pm 10 \text{ lbf} \cdot \text{ft}$)
- (4) Prepare a suitable container.
- (5) To drain the oil open the drain valve at the bottom of the oil tank.
- (6) Fill proper amount of recommended oil.
- (7) Put the breather in the right position.
- (8) Bleed air hydraulic pump loosen the air breather at top of hydraulic pump assembly.
- (9) Start engine and run continually. Release the air by full stroke of each control lever.

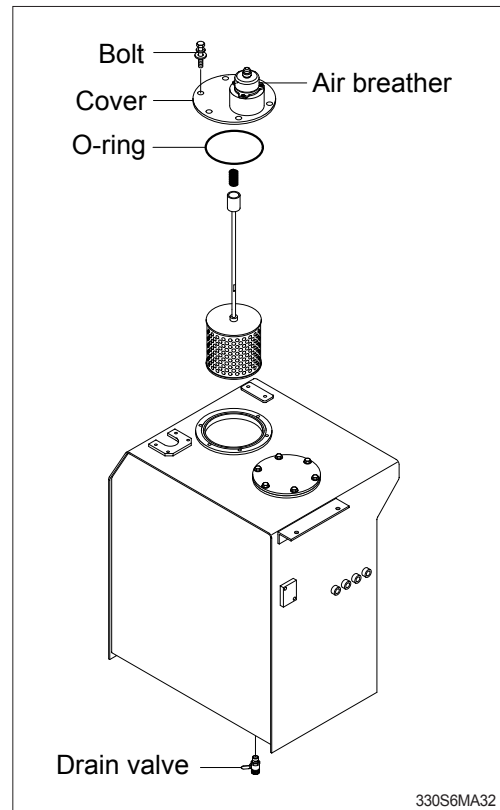

20) CLEAN SUCTION STRAINER

Clean suction strainer as follows paying attention to the cause to be kept during oil filling.

- (1) Remove the cover.
 - Tightening torque : $6.9 \pm 1.4 \text{ kgf} \cdot \text{m}$
($50 \pm 10 \text{ lbf} \cdot \text{ft}$)
 - (2) Pull out the strainer in the tank.
 - (3) Wash the foreign material on the suction strainer with gasoline or cleaning oil.
 - (4) Replace the suction strainer if it is damaged.
 - (5) Assemble with reverse order of disassembly.
Be sure to install a new O-ring and reinsert in the oil tank.
- ※ Loosen the bolt slowly at the cover can be spring out by the spring when removing it.

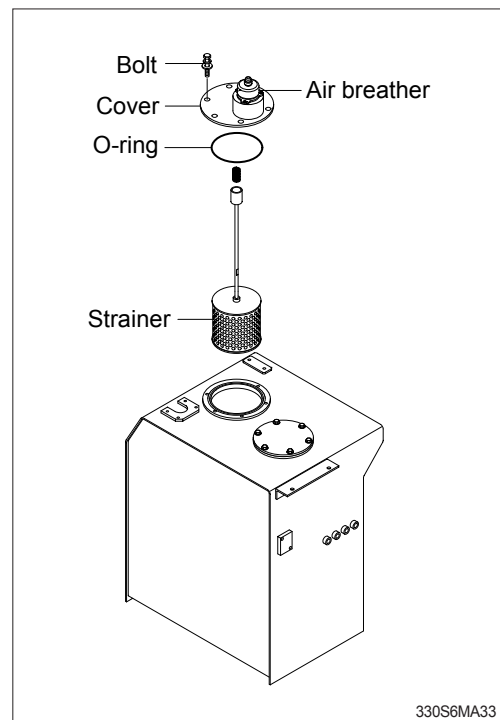

3) STARTING THE ENGINE WITH A BOOSTER CABLE

Keep following order when you are going to start engine using booster cable.

(1) Connection of booster cable

※ Use the same capacity of battery for starting.

- ① Make sure that the starting switches of the normal machine and trouble machine are both at the OFF position.
- ② Connect the red terminal of booster cable to the battery (+) terminal between exhausted and new battery.
- ③ Connect the black terminal of the booster cable between new battery (-) terminal and chassis of trouble machine.

※ Keep firmly all connection, the spark will be caused when connecting finally.

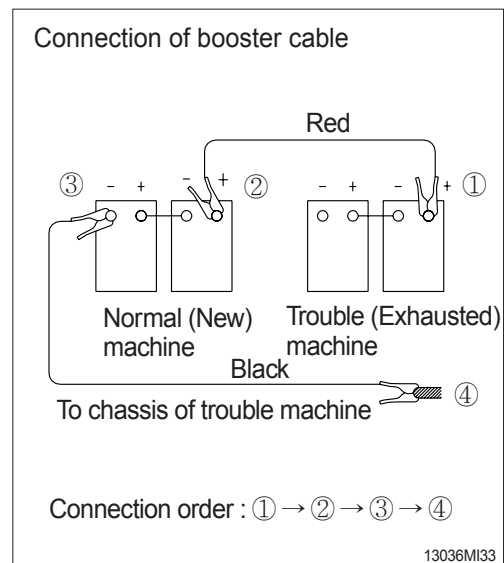

(2) Starting the engine

- ① Starting the engine of the normal machine and keep it to run at high idle.
- ② Start engine of the trouble machine with starting switch.
- ③ If you can not start it by one time, restart the engine after 2 minutes.

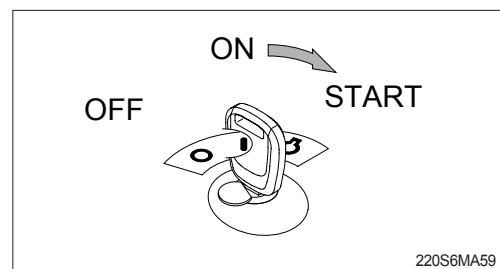

(3) Taking off the booster cable

- ① Take off the booster cable (black).
- ② Take off the booster cable (red) connected to the (+) terminal.
- ③ Run engine with high idle until charging the exhausted battery by alternator, fully.

▲ Explosive gas is generated while using the battery or charging it. Keep away flame and be careful not to cause the spark.

※ Charge the battery in the well ventilated place.

※ Place the machine on the earth or concrete. Avoid charging the machine on the steel plate.

※ Do not connect (+) terminal and (-) terminal when connecting booster cable because it will be shorted.

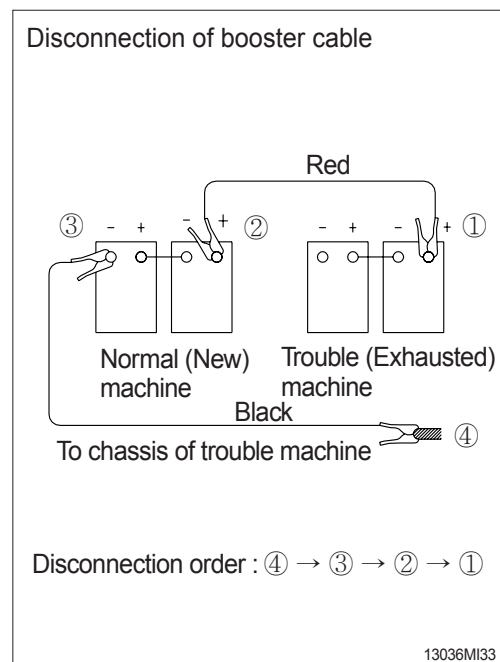

CLICK HERE TO **DOWNLOAD** THE COMPLETE MANUAL

- Thank you very much for reading the preview of the manual.
- You can download the complete manual from: www.heydownloads.com by clicking the link below



- Please note: If there is no response to CLICKING the link, please download this PDF first and then click on it.

CLICK HERE TO **DOWNLOAD** THE COMPLETE MANUAL