

Operator's Manual

ZAXIS

125US

135US

225US

225USLC

Excavator

Serial No.

ZAXIS125US 010570 and up

ZAXIS135US 062955 and up

ZAXIS225US, 225USLC 104640 and up

HITACHI

CLICK HERE TO **DOWNLOAD** THE COMPLETE MANUAL

- Thank you very much for reading the preview of the manual.
- You can download the complete manual from: www.heydownloads.com by clicking the link below



- Please note: If there is no response to CLICKING the link, please download this PDF first and then click on it.

CLICK HERE TO **DOWNLOAD** THE COMPLETE MANUAL

SAFETY

RECOGNIZE SAFETY INFORMATION

- These are the **SAFETY ALERT SYMBOLS**.
 - When you see these symbols on your machine or in this manual, be alert to the potential for personal injury.
 - Follow recommended precautions and safe operating practices.

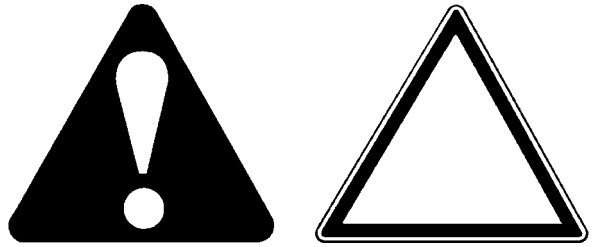

SA-688

001-E01A-0001

UNDERSTAND SIGNAL WORDS

- On machine safety signs, signal words designating the degree or level of hazard - **DANGER**, **WARNING**, or **CAUTION** - are used with the safety alert symbol.
 - **DANGER** indicates an imminently hazardous situation which, if not avoided, will result in death or serious injury.
 - **WARNING** indicates a potentially hazardous situation which, if not avoided, could result in death or serious injury.
 - **CAUTION** indicates a potentially hazardous situation which, if not avoided, may result in minor or moderate injury.
 - **DANGER** or **WARNING** safety signs are located near specific hazards. General precautions are listed on **CAUTION** safety signs.
 - Some safety signs don't use any of the designated signal words above after the safety alert symbol are occasionally used on this machine.
- **CAUTION** also calls attention to safety messages in this manual.
- To avoid confusing machine protection with personal safety messages, a signal word **IMPORTANT** indicates a situation which, if not avoided, could result in damage to the machine.
-  **NOTE** indicates an additional explanation for an element of information.



IMPORTANT



SA-1223

002-E01A-1223

SAFETY

AVOID INJURY FROM ROLLAWAY ACCIDENTS

- Death or serious injury may result if you attempt to mount or stop a moving machine.

To avoid rollaways:

- Select level ground when possible to park machine.
- Do not park the machine on a grade.
- Lower the bucket and/or other work tools to the ground.
- Turn the auto-idle switch and the H/P mode switch off.
- Run the engine at slow idle speed without load for 5 minutes to cool down the engine.
- Stop the engine and remove the key from the key switch.
- Pull the pilot control shut-off lever to LOCK position.
- Block both tracks and lower the bucket to the ground. Thrust the bucket teeth into the ground if you must park on a grade.
- Position the machine to prevent rolling.
- Park a reasonable distance from other machines.

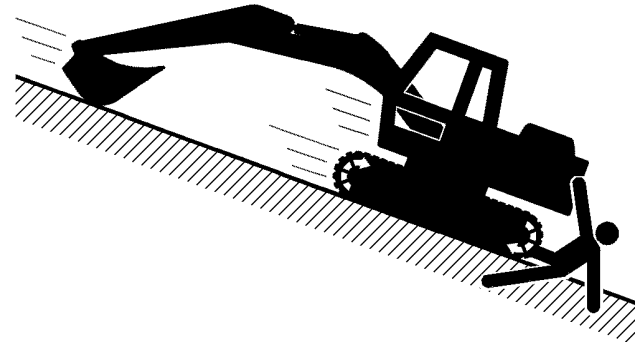

SA-391

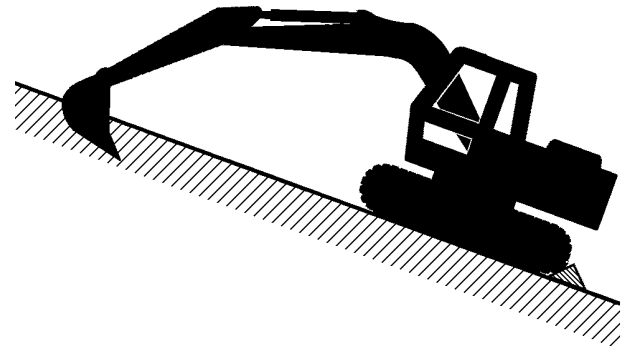

SA-392

020-E02A-0493

SAFETY

PREVENT PARTS FROM FLYING

- Grease in the track adjuster is under high pressure. Failure to follow the precautions below may result in serious injury, blindness, or death.
 - Do not attempt to remove GREASE FITTING or VALVE ASSEMBLY.
 - As pieces may fly off, be sure to keep body and face away from valve.
- Travel reduction gears are under pressure.
 - As pieces may fly off, be sure to keep body and face away from AIR RELEASE PLUG to avoid injury. GEAR OIL is hot.
 - Wait for GEAR OIL to cool, then gradually loosen AIR RELEASE PLUG to release pressure.

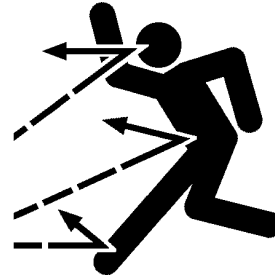

SA-344

503-E01B-0344

STORE ATTACHMENTS SAFELY

- Stored attachments such as buckets, hydraulic hammers, and blades can fall and cause serious injury or death.
 - Securely store attachments and implements to prevent falling. Keep children and bystanders away from storage areas.

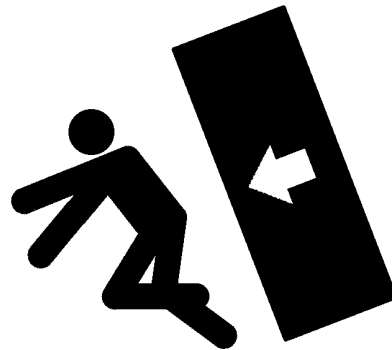

SA-034

504-E01A-0034

SAFETY SIGNS/Europe/Asia/Middle and Near East Model Only

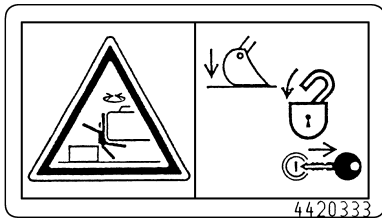

SS4420333

Caution: If the parked machine is unexpectedly moved, serious injury or death due to crushing may result. Be sure to lower the front attachment to the ground, lock the control levers, and remove the engine key before leaving the machine unattended.

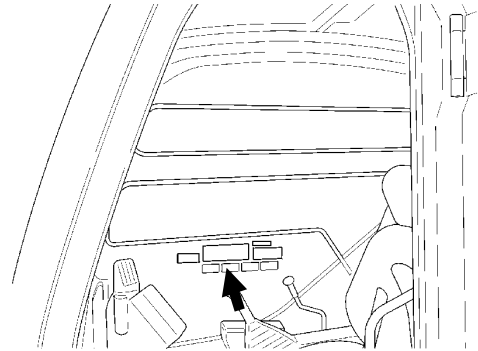

EM1SE-00-001

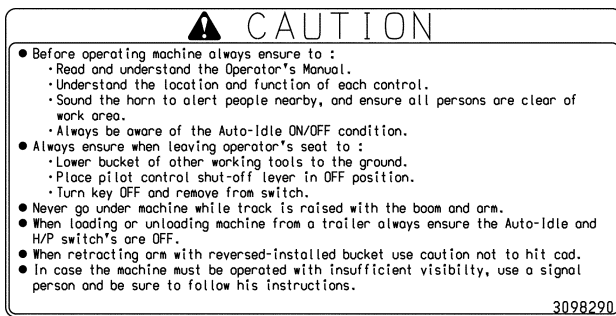

SS3098290

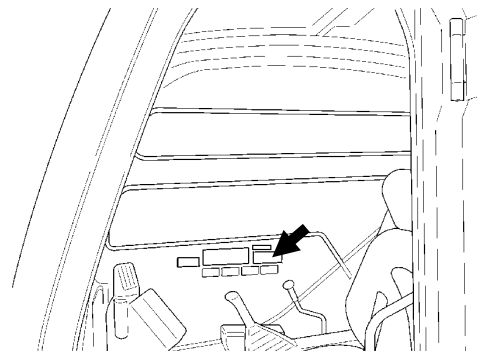

EM1SE-00-001

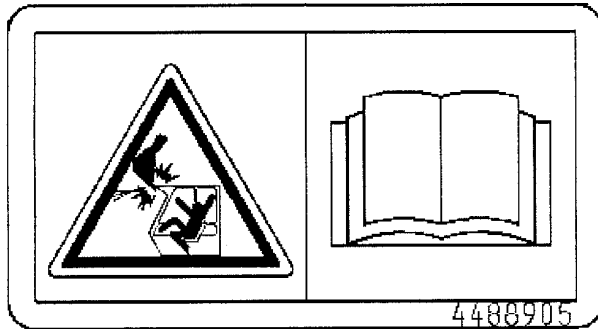

SS4488905

Caution: The bucket teeth will hit the headguard or rain-gard if the bucket is rolled in with the arm fully rolled in. When performing combined operation of arm roll-in/bucket roll-in or when rolling in the bucket with the arm fully retracted, be careful not to hit the headguard or raingard with the bucket teeth.

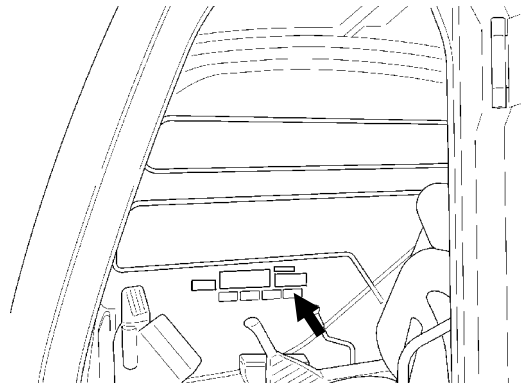

EM1SE-00-001

OPERATOR'S STATION

COOLANT TEMPERATURE GAUGE

Engine coolant temperature is indicated. Coolant temperature is normal when the needle stays in the middle zone while operating.

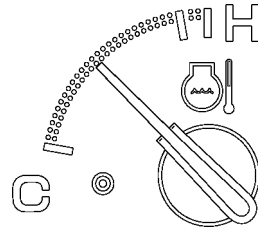

M178-01-104

FUEL GAUGE

Fuel machine before needle reaches "E".

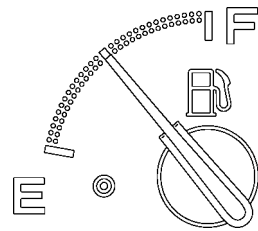

M178-01-105

AUTO-IDLE INDICATOR

Green indicator will light when the auto-idle/acceleration selector is turned to the A/I position.



M178-01-092

AUTO-ACCELERATION INDICATOR

Green indicator will light when the auto-idle/acceleration selector is turned to the A/A position.



M178-01-093

OPERATOR'S STATION

POWER MODE SWITCH

Three engine speed modes, E, P, and H/P modes, are selected by operating the power mode switch.

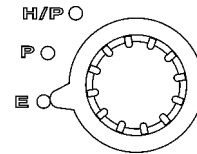

- E (Economy) Mode
Although production is slightly reduced more than in the P mode, the fuel consumption and noise levels are reduced, allowing the machine to operate efficiently.
- P Mode
Use the P mode when general digging work is needed.
- H/P (High Power) Mode
Use the H/P mode when extra horsepower is needed, i.e. when rolling in the arm in excavation work, etc.



M178-01-095

TRAVEL MODE SWITCH

Two travel modes, FAST and SLOW, are selected by turning the travel mode switch to either position.

-  Mark (Fast Speed Mode)
-  Mark (Slow Speed Mode)

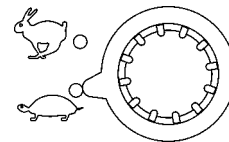

M178-01-096

OPERATOR'S STATION

PILOT CONTROL SHUT-OFF LEVER

Pilot control shut-off lever (1) functions to prevent the machine from being mistakenly operated when the operator is getting on or off the machine.

The pilot control shut-off lever is moves backward together with the console spring back mechanism, making mounting/dismounting the machine and maintenance work easier.



CAUTION:

- Pilot control will not be shut-off unless pilot control shut-off lever (1) is completely pulled-up to the LOCK position.
- Before leaving the operator's seat, always stop the engine and pull the pilot control shut-off lever up to the LOCK position.
- Also, pull the pilot control shut-off lever up to the LOCK position when transporting the machine or when the day's work is complete.
- Confirm that the pilot control shut-off lever is in the LOCK position before starting the engine.
- When moving the pilot control shut-off lever to the UNLOCK position, take care not to activate other control levers by mistake. The machine may be unexpectedly operated, possibly causing an accident or personal injury.

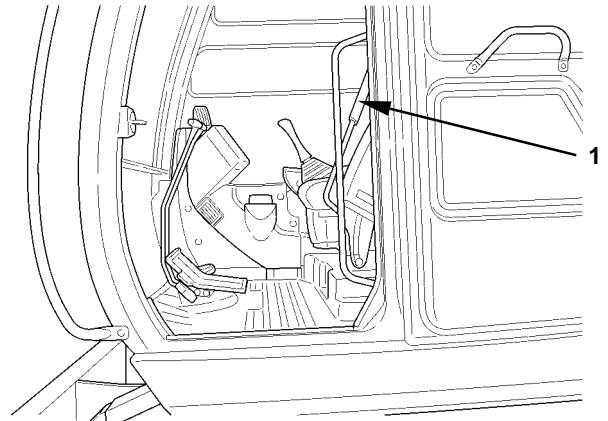

LOCK Position

M1CC-01-017

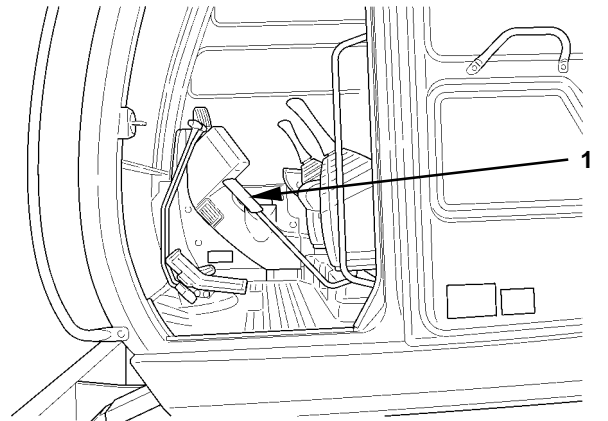

UNLOCK Position

M1CC-00-009

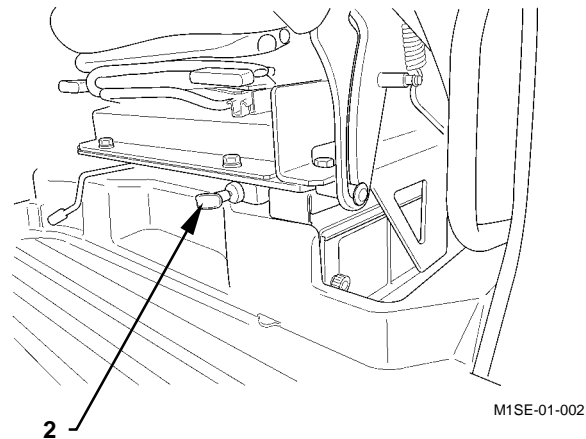

M1SE-01-002

ENGINE STOP KNOB

If the engine does not stop when the key switch is turned to the OFF position, (due to a machine or key switch malfunction), pull engine stop knob (2) all the way to the stop. The engine will stop.



NOTE: If the knob is pulled halfway, the engine may not start or may stall during operation. Be sure to push the knob to the fully retracted position before restarting the engine.

OPERATOR'S STATION

TIPS FOR OPTIMAL AIR CONDITIONER USAGE

For Rapid Cooling

Temperature in the cab may rise over 80°C (176°F) when the machine is exposed to sun light in the summer.

In this case, ventilate air in the cab first by opening the windows for rapid cooling. After starting the engine, press AUTO switch (9). Set temperature to [18.0] on LCD (7) using temperature control switch (11). Turn circulation mode switch (12) ON.

When Windows Become Clouded

If the insides of the windows become clouded during rainy weather or on humid days, operate the air conditioner to aid in keeping the windows clear. When the atmosphere is very damp, and if the air conditioner has run excessively, the outside of the windows may become clouded. If this happens, turn off the air conditioner to adjust the temperature in the cab.

Off-Season Air Conditioner Maintenance

To protect each part of the compressor from a lack of lubricant, operate the air conditioner at least once a month for several minutes with the engine running at a slow speed during off-season. When the cab temperature is lower than 15°C (59°F), the air conditioner may not operate. If this happens, warm the cab using the heater first.

- IMPORTANT:**
- Do not suddenly increase the engine speed.
 - Refer to the item "Check Air Conditioner Filter" in the Maintenance Section for maintenance of the air conditioner filters.
 - Always clean the auto air conditioner sensor for effective air conditioner performance. Avoid placing any obstructions around the sensor.

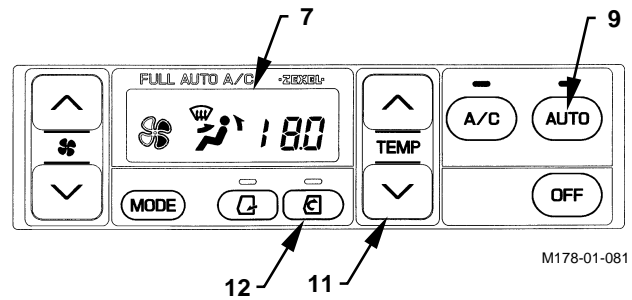

M178-01-081

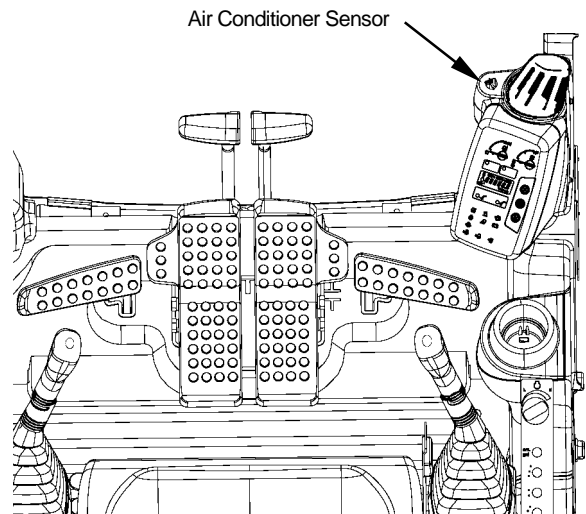

M178-01-082

OPERATOR'S STATION

EMERGENCY EXIT

If the operator's cab door should not open in an emergency, escape in the following methods:

1. Open the front windows. Escape through the windows.

 **NOTE:** See page 1-41 "OPENING UPPER FRONT WINDOWS" for the opening method of the front windows.

 **CAUTION:** Take care not to be injured with pieces of broken glass .

2. If the front window is difficult to open, break the front window glass using the emergency evacuation tool (1). Then, escape through the broken window.
3. If the front window is not available for escaping, break the rear window glass using the emergency evacuation tool. Then, escape through the broken window.

 **NOTE:** Emergency exit decals (2) are affixed to the front and rear windows.

4. If neither of front and rear windows are available for emergency exit, open the overhead window to escape from the cab.

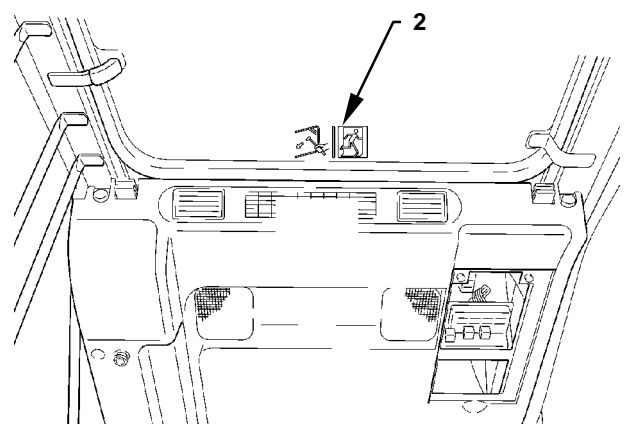
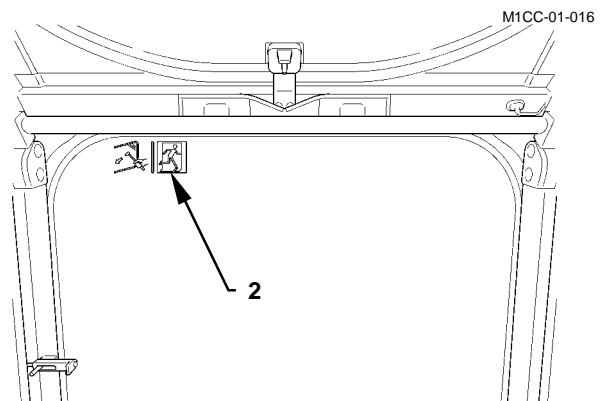
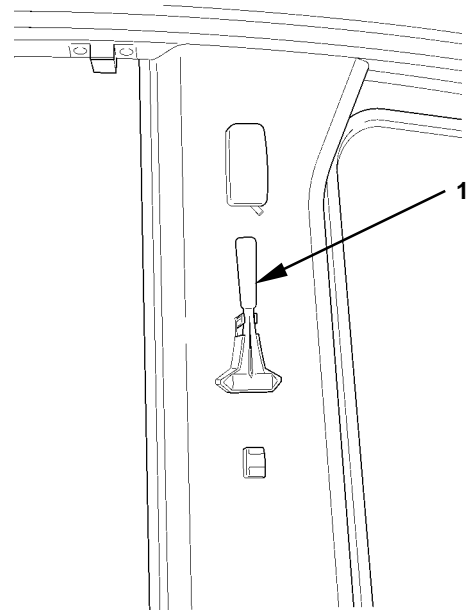

BREAK-IN

OBSERVE ENGINE OPERATION CLOSELY

IMPORTANT: Be extra cautious during the first 50 hours, until you become thoroughly familiar with the sound and feel of your new machine.

1. Operate the machine only in economy (E) mode and limit the engine horsepower up to about 80 % of full load.
2. Avoid excess engine idling.
3. Check indicator lights and gauges frequently during operation.

EVERY 8 HOURS OR DAILY

1. Perform 8-hour or daily service. (See Maintenance guide -- 8 hours.)
2. Watch for fluid leaks.
3. Lubricate working tool pivots every 8 hours for the first 50 hours, and every 8 hours when working in mud and water.

AFTER THE FIRST 50 HOURS

1. Perform 50-hour service. (See Maintenance guide -- 50 hours.)
2. Check accessible hardware torque. (See Hardware Torque Specifications in Maintenance chapter.)

AFTER THE FIRST 100 HOURS

Perform 50-hour and 100-hour service. (See Maintenance Guide -- 50 hours and 100 hours.)

DRIVING THE MACHINE

DRIVE THE MACHINE CAREFULLY

IMPORTANT: During freezing weather, park machine on a hard surface to prevent tracks from freezing to the ground. Clean debris from tracks and track frame.

If tracks are frozen to the ground, raise tracks using boom, move machine carefully to prevent damage to drive train and tracks.

Select a route that is as flat as possible. Steer machine as straight as possible making small, gradual changes in direction.

When driving over rough terrain, reduce engine speed to lessen possibility of undercarriage damage.

 **NOTE:** An arrow-mark seal is stuck on the inside surface of the side frame to indicate the machine front direction.

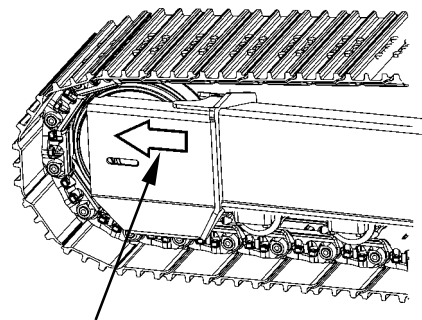

Arrow-mark

M178-03-001

OPERATING THE MACHINE

CONTROL LEVER (ISO PATTERN)



CAUTION: Never place any part of body beyond window frame. It could be crushed by the boom if boom control lever is accidentally bumped or otherwise engaged. If window is missing or broken, replace immediately. Prevent possible injury from unexpected machine movement. Make sure you know the location and function of each control before operating.

The machine is equipped with a label showing the control patterns of the levers and pedals.

IMPORTANT: When digging, avoid hitting tracks with boom cylinders. When digging over the end of the tracks, travel motors should be at the rear to maximize machine stability and lift capacity.

When a lever is released, it will automatically return to neutral, and that machine function will stop.

- 1- Arm Roll-Out
- 2- Arm Roll-In
- 3- Swing Right
- 4- Swing Left
- 5- Boom Lower
- 6- Boom Raise
- 7- Bucket Roll-In.
- 8- Bucket Roll-Out.

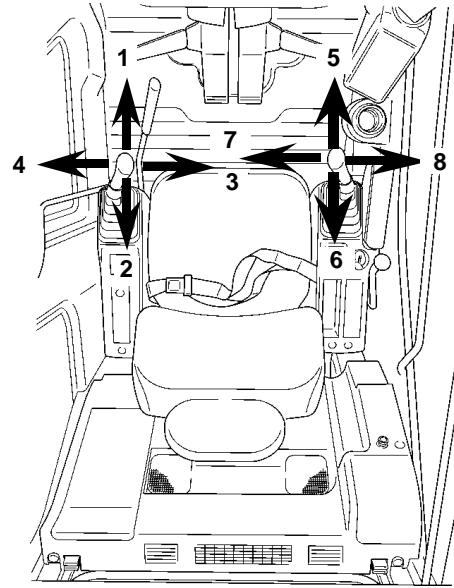

M1CC-01-010

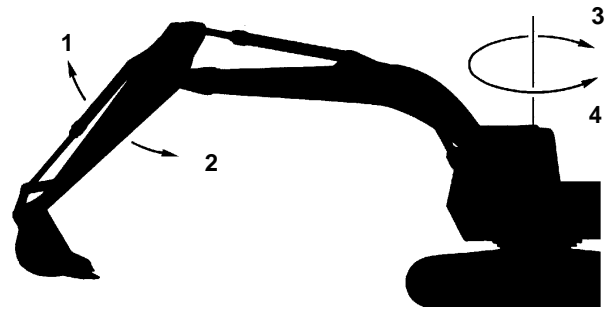

M104-05-001

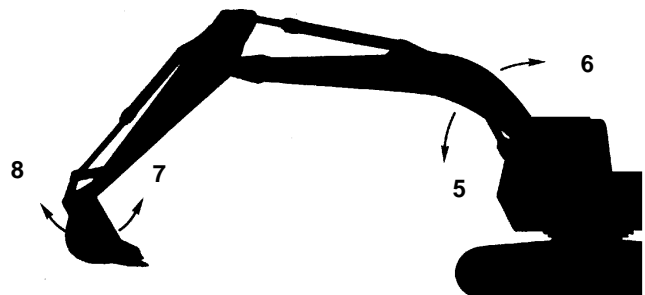

M104-05-002

OPERATING THE MACHINE

WORK MODE

Two work modes can be selected for most appropriate front and swing speeds for the work to be performed.

When the engine is started, the digging mode is automatically set. Each time work mode switch (1) is pressed, the two following modes are selected alternately.

- Digging Mode
- Attachment Mode

The selected work mode is indicated by attachment mode indicator (2) or digging mode indicator (3). Select the work mode corresponding to the work in which the machine is engaged while referring to the table below.

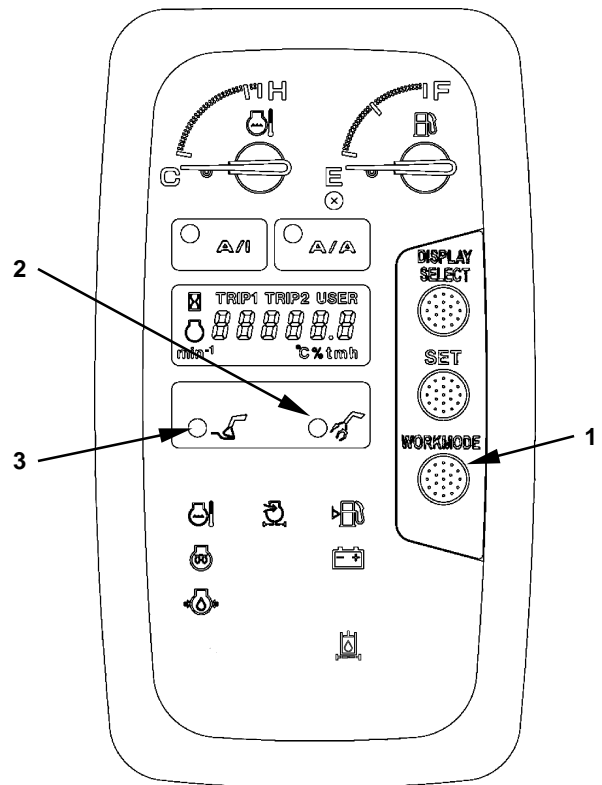

M1SE-01-005

| | Work Mode | Description |
|--|----------------------|--|
| | General Purpose Mode | Designed for general digging and truck loading. |
| | Attachment Mode | Select this mode when using attachments other than bucket. |

POWER BOOST ZAXIS225US, 225USLC

The power boost switch (4) is used to gain maximum digging power, and is located on the top of the right control lever.

When the power boost switch (4) is pushed, increased front attachment power will be supplied for about 8 seconds.

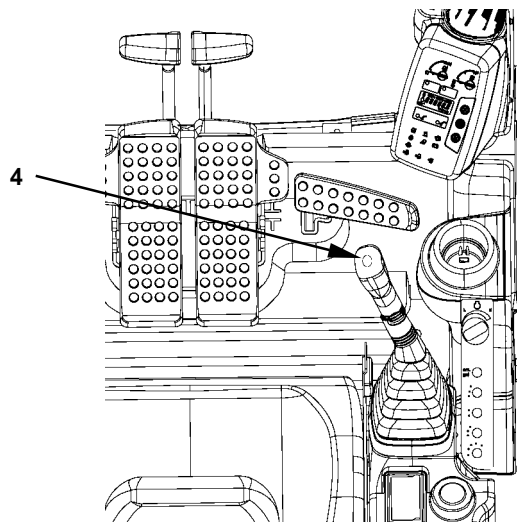

M178-05-002

OPERATING THE MACHINE

PIPINGS FOR BREAKER AND CRUSHER

(ZAXIS225US, 225USLC)

Operational procedures for stop valves and selection valve.

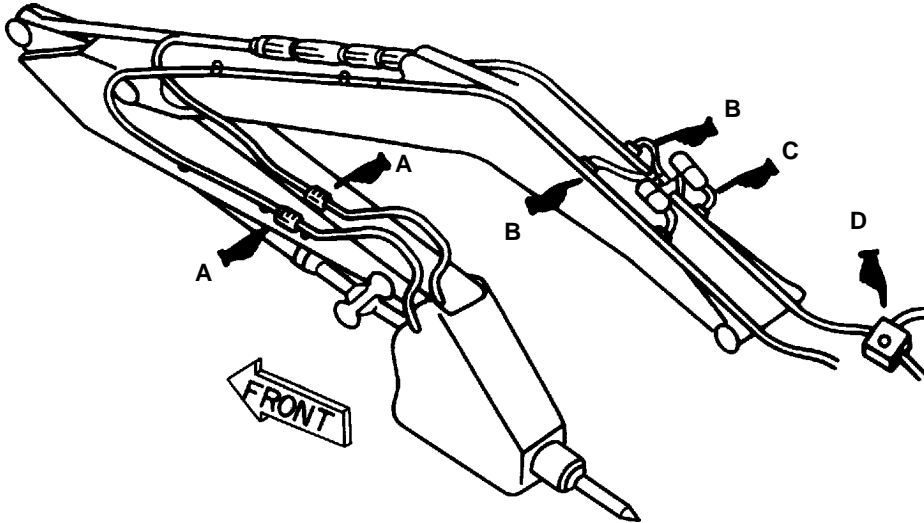

| | | |
|--------------------------|--------------------|--|
| A, B Stop Valves | Close | |
| | Open | |
| C Stop Valves | Close | |
| | Open | |
| D Selection Valves | when using breaker | |
| | when using crusher | |

M107-05-003

| Stop Valves A | Stop Valves B | Stop Valves C |
|---|---|--|
| Close : When not using attachment or is detached. | Close : When using crusher or NPK breaker | Close : When using crusher or breaker except NPK |
| Open : When using attachment | Open : When using breaker (except NPK) | Open : When Using NPK breaker |

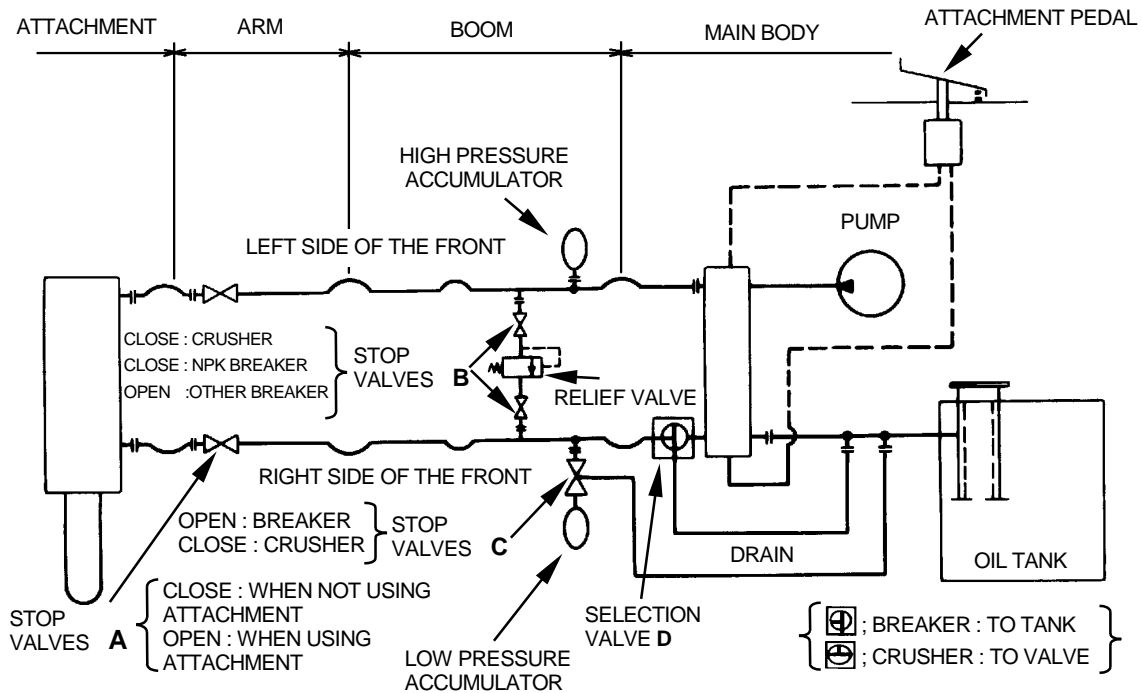

IMPORTANT: Be sure to close stop valve (B) for the low pressure accumulator when using the crusher.

Using the crusher with stop valve (B) for the low pressure accumulator open will result damages to the accumulator.

OPERATING THE MACHINE

Crusher (ZAXIS125US, 135US, 135USK)

| Maker | SANGO JYUKI | NPK※ | Sakado | Oosumi | STK※ |
|--|----------------|----------------|----------------|-----------------|----------------|
| Model | TS700RCD | S-15X | SPAC70R-3 | MR800 | CX750 |
| Weight kg (lb) | 1200 (2650) | 1410 (3110) | 1300 (2870) | 1400 (3090) | 1250 (2760) |
| Overall Length mm (ft-in) | 1980 (6'6") | 2230 (7'4") | 1620 (5'4") | 1900 (6'3") | 2000 (6'7") |
| Rated Pressure Mpa (kgf/cm ²) | 24.5 (250) | 20.6 (210) | 27.4 (280) | ~31.4 (~320) | 27.4 (280) |
| Maximum Opening Width mm (ft-in) | 700 (2'4") | 750 (2'6") | 750 (2'6") | 800 (2'8") | 750 (2'6") |
| Swing Method | Free | Free | — | Free | Free |

Crusher (ZAXIS 225US, 225USLC)

| Maker | | HITACHI | | SANGO JYUKI | NPK※ | Sakado | Oosumi | STK※ |
|--|-------------|----------------|----------------|----------------|----------------|-----------------|-----------------|----------------|
| Model | | HSK100 | HSC160 | TS850RCD | S-22XA | SPAC80R-3 | MR1 100-2 | CX1 100 |
| Weight kg (lb) | | 2430 (5360) | 2300 (5070) | 2000 (4410) | 2000 (4410) | 1640 (3620) | 2100 (4630) | 2350 (5180) |
| Overall Length mm (ft-in) | | 2340 (7'8") | 2600 (8'6") | 2500 (8'2") | 2500 (8'2") | 1810 (5'11") | 2100 (6'11") | 2450 (8'0") |
| Rated Pressure Mpa (kgf/cm ²) | | 27.9 (285) | 27.9 (285) | 27.4 (280) | 24.5 (250) | 27.4 (280) | 27.4 (280) | 27.4 (280) |
| Maximum Opening Width mm (ft-in) | | 900 (2'11") | 850 (2'9") | 850 (2'9") | 850 (2'9") | 850 (2'9") | 1000 (3'3") | 1100 (3'7") |
| Swing Method | | Hydraulic | Hydraulic | Free | Free | Free | Free | Free |
| Jaw Tip Crushing Force | Kn (ton) | 640 (65) | | 980 (100) | 970 (99) | 630 (64) | | 590 (60) |
| Jaw Center Crushing Force | Kn (ton) | 980 (100) | 1570 (160) | 1570 (160) | | 780 (80) | 1540 (157) | 880 (90) |

CLICK HERE TO **DOWNLOAD** THE COMPLETE MANUAL

- Thank you very much for reading the preview of the manual.
- You can download the complete manual from: www.heydownloads.com by clicking the link below



- Please note: If there is no response to CLICKING the link, please download this PDF first and then click on it.

CLICK HERE TO **DOWNLOAD** THE COMPLETE MANUAL

TRANSPORTING

TRANSPORTING BY ROAD

When transporting the machine on public roads, be sure to first understand and follow all local regulations.

- When transporting using a trailer, check the width, height, length and weight of the trailer with the machine loaded.
Note that transporting the weight and dimensions may vary depending on the type of shoe or front attachments installed.
- Investigate beforehand the conditions of the route to be traveled, such as dimensional limits, weight limits, and traffic regulations.



M107-06-013

In some cases, disassemble the machine to bring it within dimensional limits or weight limits of local regulations.

LOADING/UNLOADING ON A TRAILER

Always load and unload the machine on a firm, level surface.



CAUTION: Be sure to use a loading dock or a ramp for loading/unloading.

Ramp/Loading Dock:

- Before loading, thoroughly clean the ramp and flatbed. Dirty ramps or flatbeds with oil, mud, or ice on them are slippery and dangerous.
- Place blocks against the truck and trailer wheels while using a ramp or loading dock.
- Ramps must be sufficient in width, length, and strength. Be sure that the incline of the ramp is less than 15 degrees.
- Loading docks must be sufficient in width and strength to support the machine and have an incline of less than 15 degrees.

MAINTENANCE

Maintenance Guide Table

Sample : ZAXIS225US, 225USLC

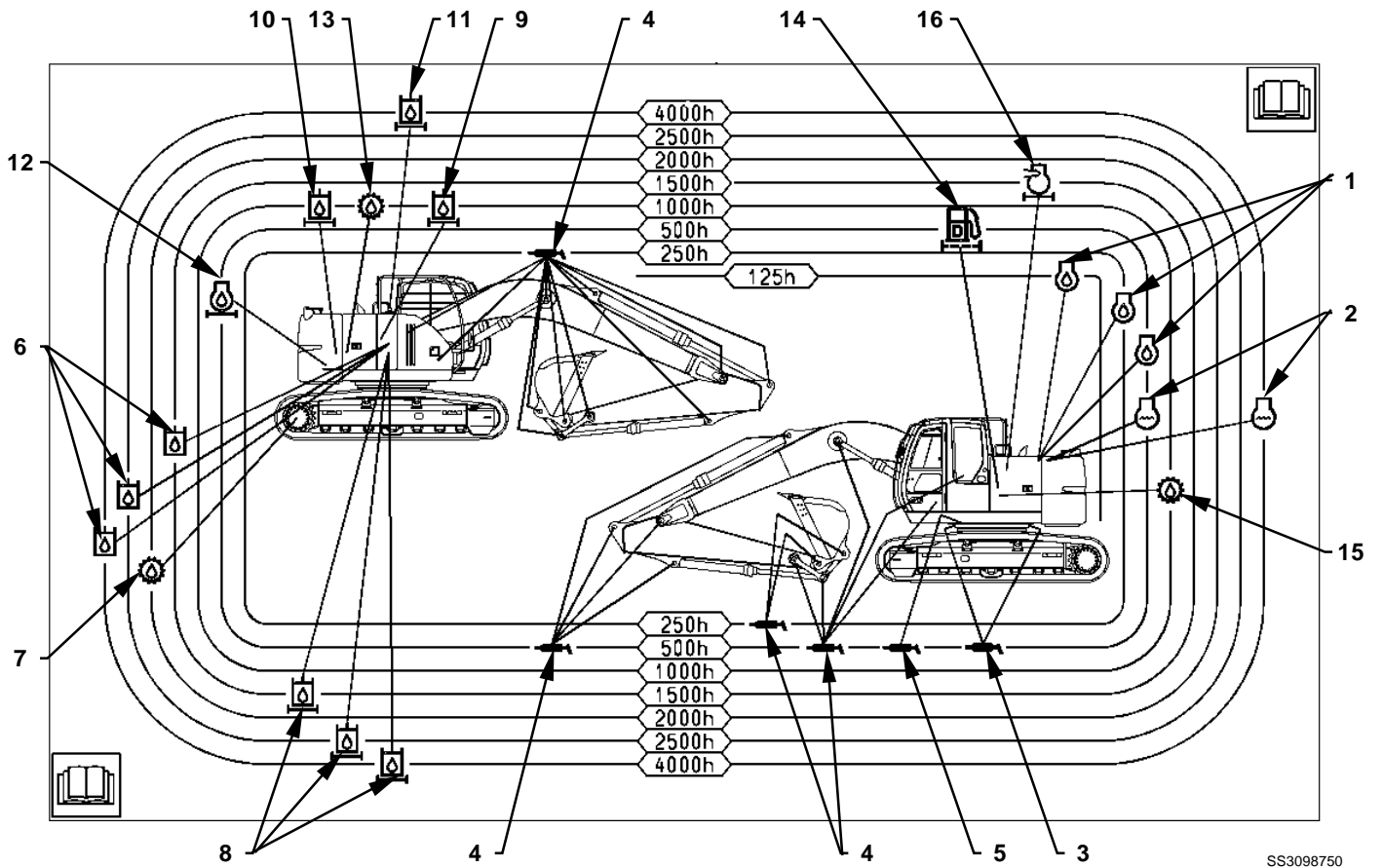

SS3098750

MAINTENANCE

A. GREASING

1 Front Joint Pins

Bucket --- every 250 hours

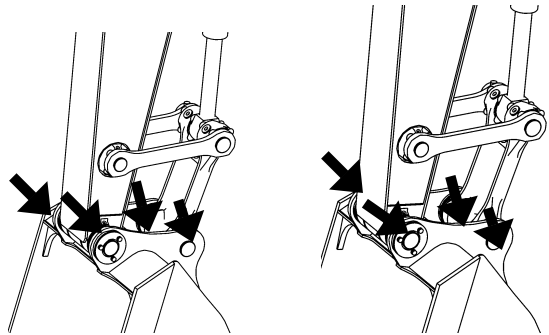

ZAXIS125US, 135US, 135USK

ZAXIS225US, 225USLC

M178-07-007

Link Pins --- every 500 hours

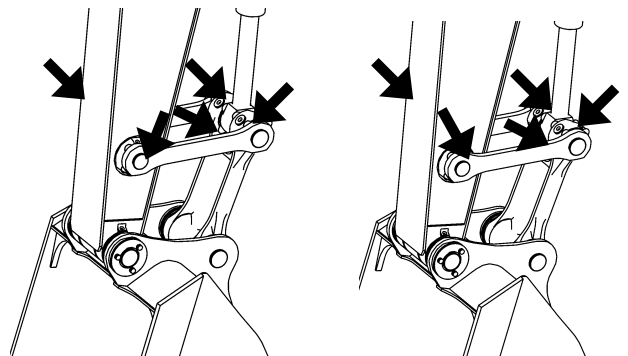

ZAXIS125US, 135US, 135USK

ZAXIS225US, 225USLC

M178-07-007

Others --- every 500 hours

- Boom Foot

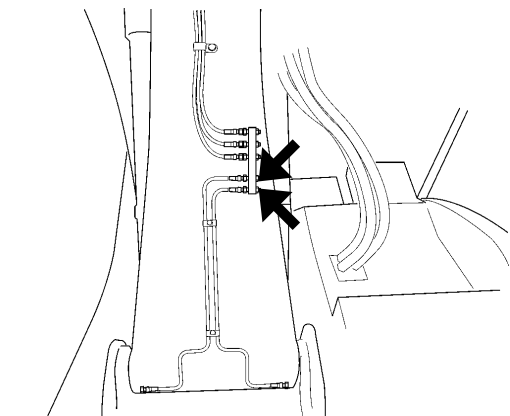

ZAXIS125US, 135US, 135USK

M15E-07-003

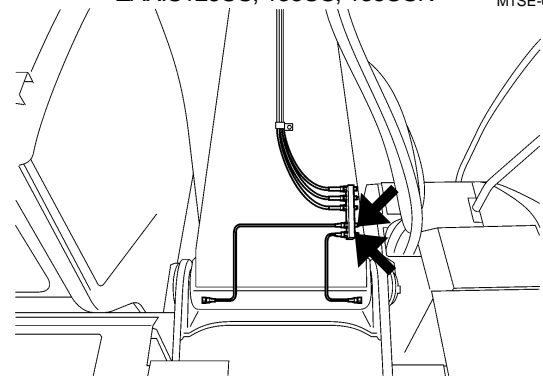

ZAXIS225US, 225USLC

M16F-07-019

MAINTENANCE

D. HYDRAULIC SYSTEM

INSPECTION AND MAINTENANCE OF HYDRAULIC EQUIPMENT



CAUTION: During operation, the parts of the hydraulic system become very hot. Allow the machine to cool down before beginning inspection or maintenance.

1. Be sure that the machine is parked on a level, firm surface before servicing hydraulic equipment.
2. Lower the bucket to the ground and stop the engine.
3. Begin servicing hydraulic components only after components, hydraulic oil and lubricants are completely cooled, and after releasing residual pressure.
 - 3.1 Bleed air from the hydraulic oil tank to release internal pressure.
 - 3.2 Allow the machine to cool down.
Note that servicing heated and pressurized hydraulic components may cause hot parts and/or oil to fly off or escape suddenly, possibly resulting in personal injury.
 - 3.3 Keep body parts and face away from plugs or screws when removing them.
Hydraulic components may be pressurized even when cooled.
 - 3.4 Never attempt to service or inspect the travel and swing motor circuits on slopes. They are highly pressurized due to self-weight.
4. When connecting hydraulic hoses and pipes, take special care to keep seal surfaces free from dirt and to avoid damaging them. Keep these precautions in mind:
 - 4.1 Wash hoses, pipes, and the tank interior with a washing liquid and thoroughly wipe it out before re-connecting them.
 - 4.2 Only use O-rings that are free of damage or defects. Be careful not to damage them during reassembly.
 - 4.3 Do not allow high pressure hoses to twist when connecting them. The life of twisted hoses will be shortened considerably.
 - 4.4 Carefully tighten low pressure hose clamps. Do not overtighten them.
5. When adding hydraulic oil, always use the same brand of oil; do not mix brands of oil. As the machine is filled with Super EX 46HN when it is shipped from the factory, use it as a general rule. When selecting to use another brand of oil listed in the table "Brand names of recommended hydraulic oil", be sure to completely replace the oil in the system.
6. Do not use hydraulic oils other than those listed in the table "Brand names of recommended hydraulic oil".
7. Never run the engine without oil in the hydraulic oil tank.

MAINTENANCE

7

Replace Air Breather Element --- every 4000 hours



CAUTION: Hydraulic oil may be hot just after operation. Hot hydraulic oil may spout, possibly causing severe burns. Be sure to wait for oil to cool before starting work.

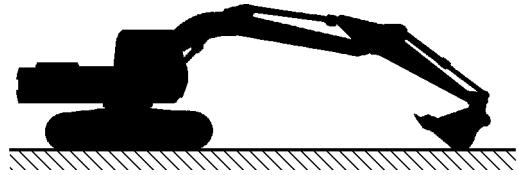

M104-07-021

Replacement Procedures

1. Park the machine on solid and level ground. Fully extend the bucket cylinder, fully retract the arm cylinder, and lower the bucket to the ground as illustrated to the right. Stop the engine.
2. Before replacing the element, be sure to bleed air pressure from the hydraulic oil tank by pressing the air bleed valve on the hydraulic oil tank.
3. Turn cover (2) clockwise about 1/4 turn. Turn cap (1) counterclockwise to remove it.
4. Turn cover (2) counterclockwise to remove it. Then, remove element (3).
5. Install new element (3). Tighten to install cover (2) until cover (2) comes in contact with the element. Then, further tighten the cover 1/4 turn.
6. Securely tighten cap (1) clockwise by hand. While holding cap (1) by hand so that cap (1) doesn't rotate, securely tighten cover (2) by rotating counterclockwise 5 to 10° by hand.
7. Take care never to allow water and/or contaminant to stay between cover (2) and body (4) (air breathing port).
8. Replace the element periodically to keep hydraulic oil clean and to extend hydraulic components service life.

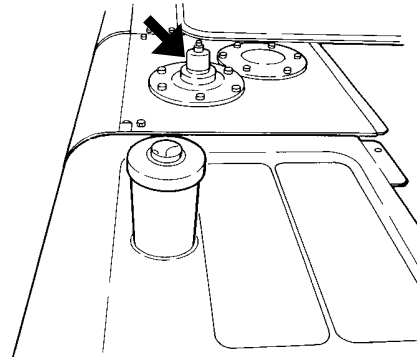

M157-07-185

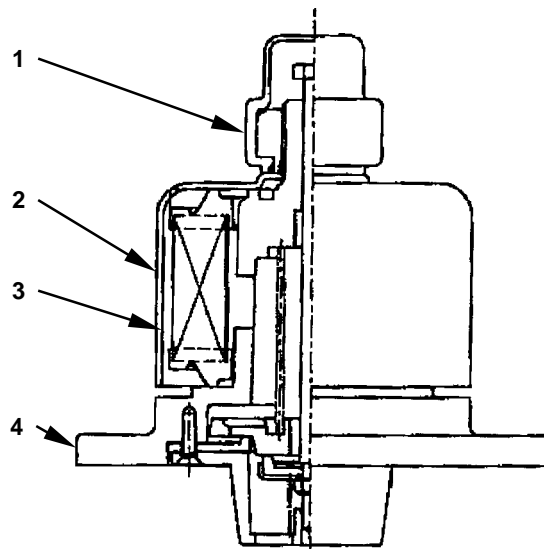

M1G6-07-001

MAINTENANCE

Bleed Air from Fuel System

ZAXIS225US, 225USLC

IMPORTANT: Air in the fuel system may make the engine hard to start or make it run irregularly. After draining water and sediment from the water separator, replacing the fuel filter, cleaning the feed pump strainer or running the fuel tank dry, be sure to bleed the air from the fuel system.

1. Confirm that drain plug (3) and air bleed plug (1) on water separator (2) are tight. If air bleed plug (1) is not tight, air will not bleed from the fuel system.
2. Confirm that fuel cock (4) is opened.
3. Loosen air bleed plug (5) on the fuel filter.
4. Loosen fuel feed pump (6) knob, raise and lower the plunger until no more air bubbles can be seen in the fuel.
5. Tighten air bleed plug (5) on the fuel filter. Raise and lower the fuel feed pump plunger until the load becomes heavy.
6. Push fuel feed pump (6) knob down and tighten.
7. Start the engine and run at slow idle.
8. Put a "Do Not Operate" tag on the right control lever.
9. Pull the pilot control shut-off lever to the LOCK position.
10. Inspect the fuel system for leaks.

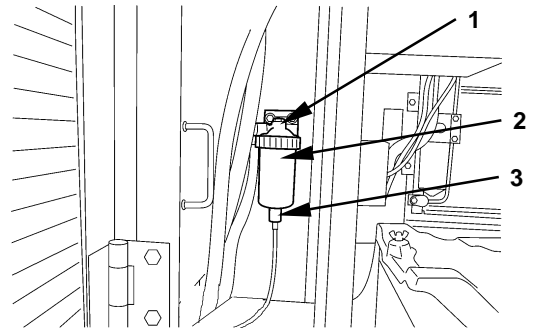

M1GF-07-008

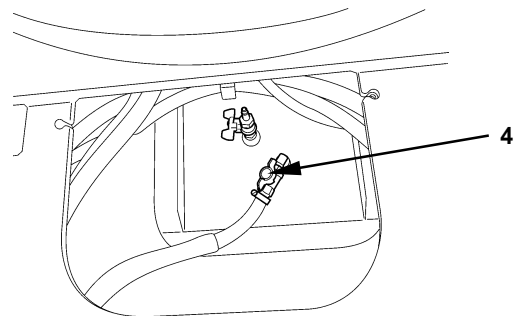

M1GF-07-010

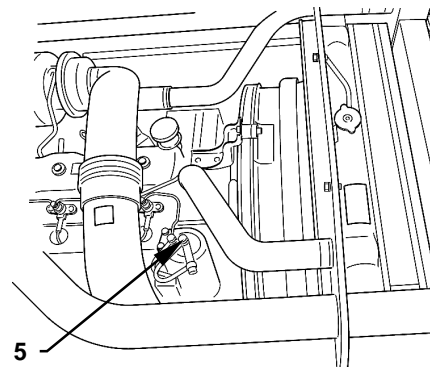

SS-2110

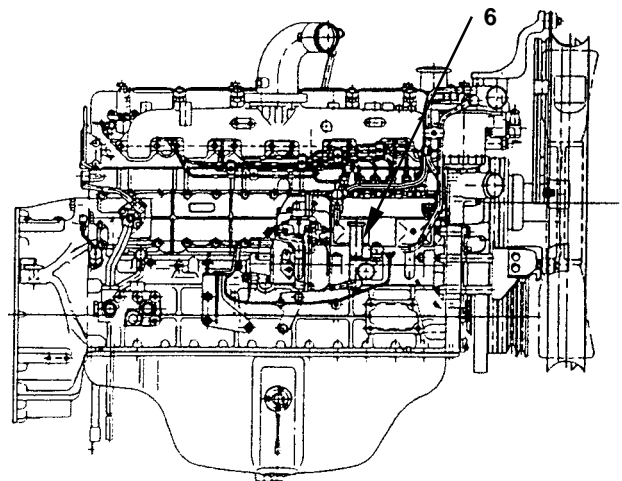

M178-07-025

MAINTENANCE

- 5** Clean Intercooler Core
(ZAXIS135US, 135USK, 225US, 225USLC),
Radiator, and Oil Cooler Core

- 6** Clean Oil Cooler Front Screen
--- every 500 hours

CAUTION: Use reduced compressed air pressure (Less than 0.2 MPa, 2 kgf/cm²) for cleaning purposes. Clear the area of bystanders, guard against flying chips, and wear personal protection equipment including eye protection.

IMPORTANT: When operating the machine in a dusty environment, check the screen every day for dirt and clogging. If clogged, remove, clean and reinstall the screen.

1. Open the radiator access door and hood.
2. Clean the air conditioner condenser.
3. Remove the oil cooler front screen and clean it.
4. Clean both the radiator and oil cooler using compressed air (Less than 0.2 MPa, 2 kgf/cm²) or water.

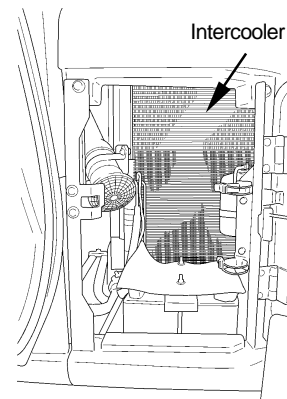

ZAXIS135US, 135USK

M1SE-07-028

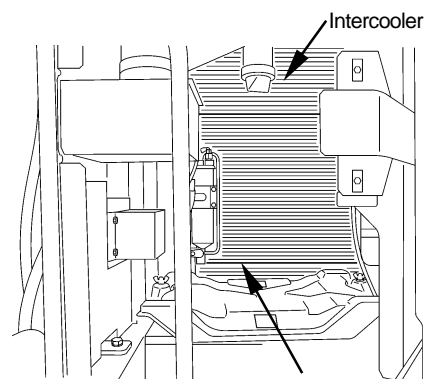

ZAXIS225US, 225USLC

M1GF-07-015

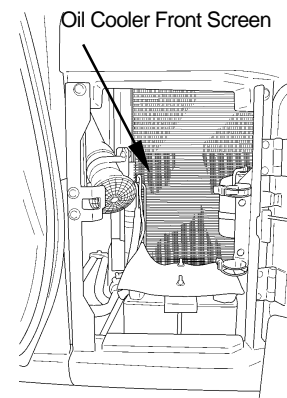

ZAXIS125US, 135US, 135USK

M1SE-07-028

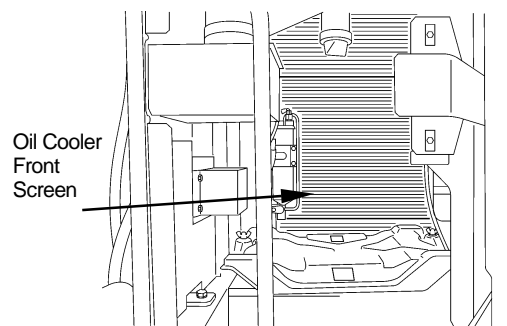

ZAXIS225US, 225USLC

M1GF-07-015

MAINTENANCE

2

Change Bucket



CAUTION: When driving the connecting pins in or out, guard against injury from flying pieces of metal or debris; wear goggles or safety glasses, and safety equipment appropriate to the job.

1. Park the machine on a level surface. Lower the bucket to the ground and position it with the flat surface resting on the ground. Be sure the bucket will not roll when the pins are removed.
2. Slide the O-rings out of the way, as shown.
3. Remove bucket pins A and B to separate the arm and bucket. Clean the pins and pin bores. Apply sufficient grease to the pins and pin bores.
4. Align the arm and alternate bucket. Be sure the bucket will not roll.
5. Install bucket pins A and B.
6. Install the locking pins and snap ring on pins A and B.
7. Adjust bucket linkage clearance for pins A. See adjusting bucket linkage clearance procedure.
8. Apply grease to pin joints A and B.
9. Start the engine and run at slow idle. Slowly operate the bucket in both directions to check for any interference in bucket movement. Do not operate a machine that has any movement interference. Correct interference problem.

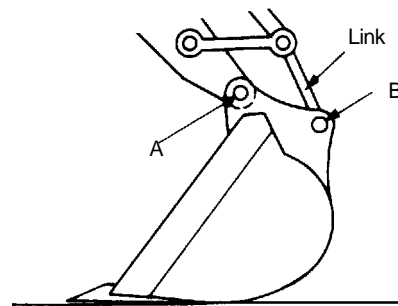
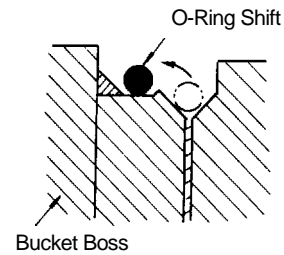

M104-07-063

MAINTENANCE

10 Check the Air Conditioner --- daily

1. Check pipe connections for refrigerant gas leakage. If oil seepage is found around pipe connections, as illustrated, it indicates possible gas leakage.
2. Check refrigerant quantity. After running the engine at 1500 min^{-1} (rpm) for 2 to 3 minutes, check refrigerant quantity through the sight glass on the receiver tank.
3. Check the condenser. If the condenser fins become clogged with dirt or insects, the cooling effect will be decreased. Be sure to keep it clean at all times. (Refer to "Clean Radiator Core" in Maintenance Section.)
4. Check the compressor. After operating the air conditioner for 5 to 10 minutes, touch the high-pressure side and low-pressure side pipes with your hand. If normal, the high-pressure side pipe will be hot, and the low-pressure side cold.
5. Check mounting bolts for looseness. Confirm that the compressor mounting bolts and other mounting/fastening bolts are securely tightened.
6. Inspect belt, check and adjust tension. Visually check the compressor belt for wear. Check and adjust belt tension, referring to the illustration (right).

Compressor belts

Depressing Force: approximately 100 N (10 kgf, 22 lbf)

Deflection: 8 to 12 mm (0.35 to 0.47 in)

If any abnormalities are found in air conditioner operation, see your authorized dealer for inspection.

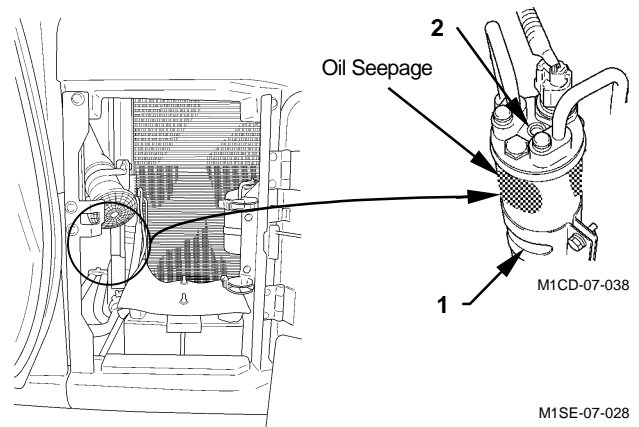

ZAXIS125US, 135US, 135USK

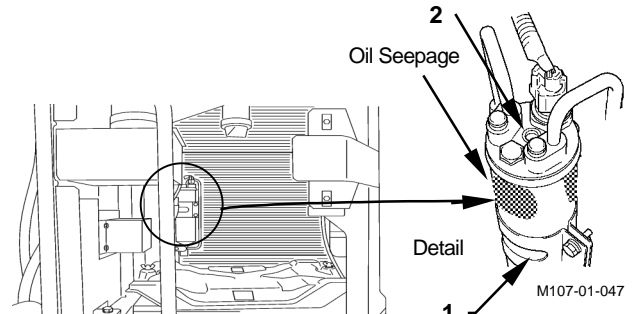

ZAXIS225US, 225USLC

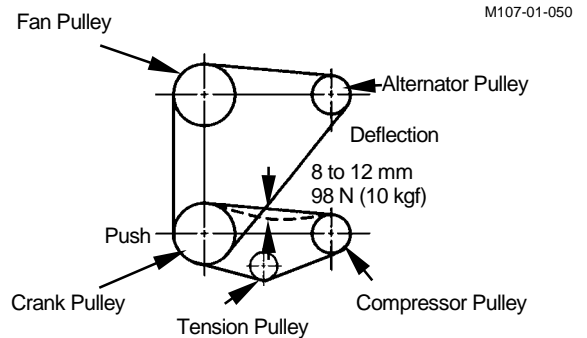
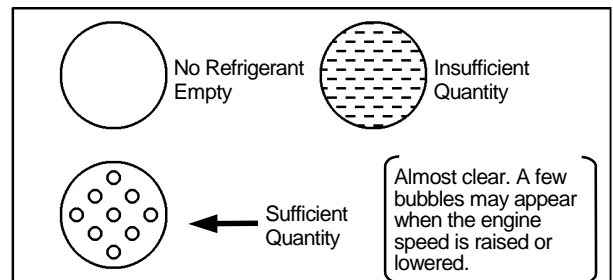

M178-07-039

MAINTENANCE

14. Retighten the travel device mounting bolts.

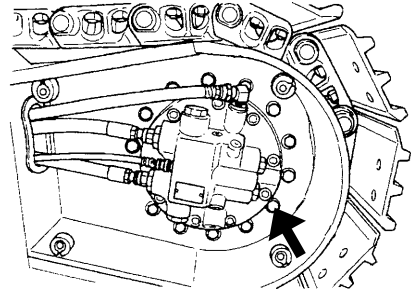

M154-12-002

Retighten the travel reduction device cover mounting bolts.

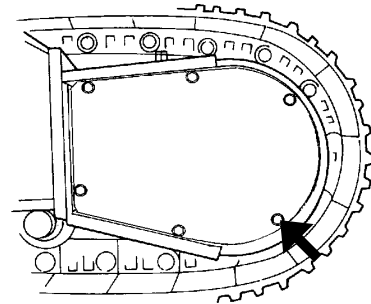

M1G6-07-007

15. Retighten the sprocket mounting bolts.

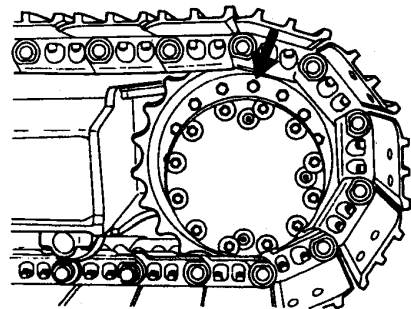

M154-07-050

16. Retighten the upper roller mounting bolts.

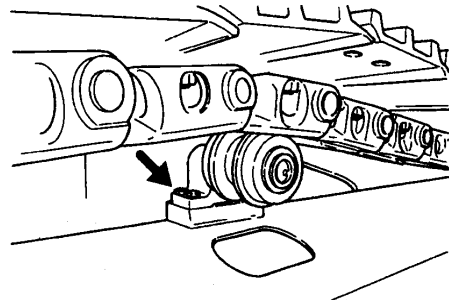

M154-07-051

17. Retighten the lower roller mounting bolts.

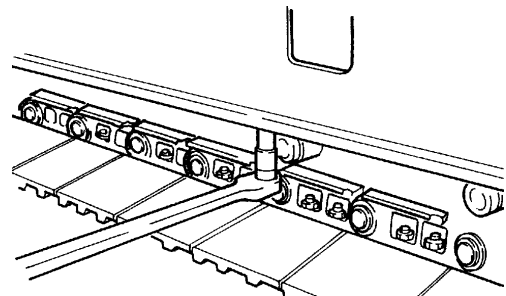

M104-07-090

STORAGE

INSTALLING VANDAL-PROOF COVERS

1. Location of each vandal-proof covers to be installed are shown.
2. In each section, install covers in order of the numbering.
3. Lock covers in each section when finished the installation.

 **NOTE:** In case the sunshade is installed on the top of the cab, remove the cover (2) and (3) shown below from cab front (1). Then, install cover (1).

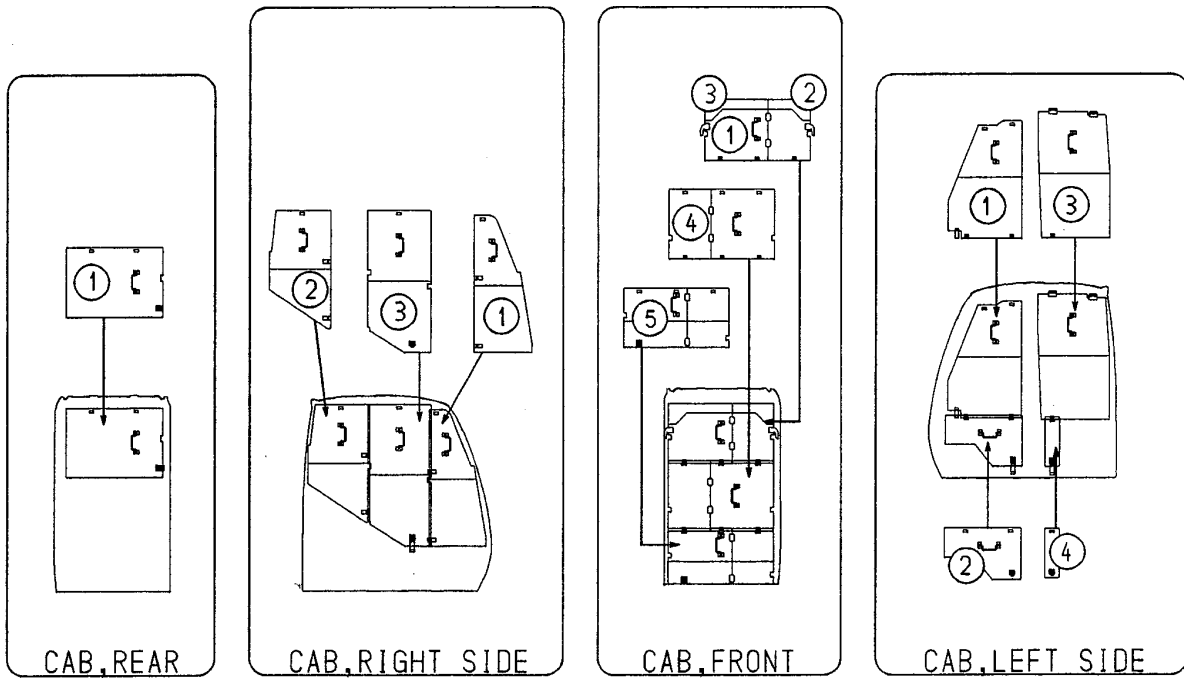

M1CD-10-001

TROUBLESHOOTING

ELECTRICAL SYSTEM

| Problem | Cause | Solution |
|--|--|---|
| No Indicators in Gauge Panel Operate | Circuit board Wiring harness Fuse | See your authorized dealer. See your authorized dealer. Replace fuse. |
| Indicator Light in Gauge Panel is Inoperative | Bulb Fuse Sender Wiring harness failure | Replace bulb. Replace fuse. Do sender check. See your authorized dealer. |
| Coolant Temperature Gauge Does Not Work | Fuse Gauge Gauge sender Wiring harness | Replace fuse. See your authorized dealer. Do coolant temperature gauge sender check. See your authorized dealer. |
| Indicator Lights Do Not Operate Auto-idle | Fuse Bulb Auto-idle switch | Replace fuse. Replace bulb. See your authorized dealer. |
| Fuel Gauge Does Not Work | Fuse Gauge Wiring harness | Replace fuse. See your authorized dealer. See your authorized dealer. |

SPECIFICATIONS

WORKING RANGES

ZAXIS135US

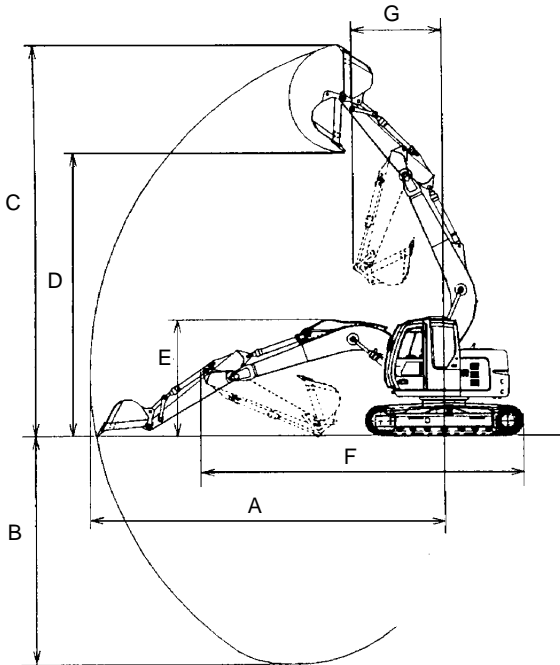

Backhoe

T1SE-01-01-002

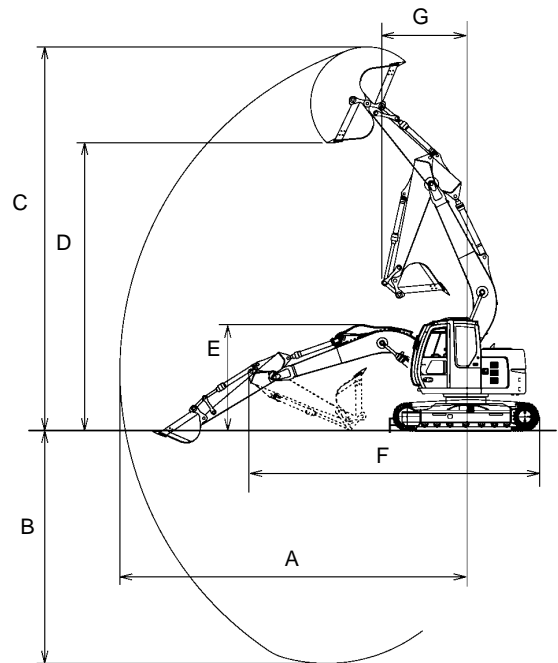

Shovel

M1SE-12-001

| Model | | ZAXIS135US | | | | | |
|-------------------------------|---------------|---------------------|-------------------|--------------------|-------------------|---------------------|---------------------|
| | | 2.10 m (6' 11") Arm | | 2.52 m (8' 3") Arm | | 3.01 m (9' 11") Arm | |
| Item | Category | Backhoe | Shovel | Backhoe | Shovel | Backhoe | Shovel |
| A : Maximum Digging Reach | mm (ft-in) | 7930 (26' 0") | 8080 (26' 6") | 8300 (27' 3") | 8440 (27' 8") | 8760 (28' 9") | 8910 (29' 3") |
| *1 B : Maximum Digging Depth | mm (ft-in) | 5120 (16' 10") | 5270 (17' 3") | 5530 (18' 2") | 5680 (18' 8") | 6020 (19' 9") | 6170 (20' 3") |
| *1 C : Maximum Cutting Height | mm (ft-in) | 8950 (29' 4") | 9100 (29' 10") | 9220 (30' 3") | 9370 (30' 9") | 9610 (31' 6") | 9760 (32' 0") |
| *1 D : Maximum Dumping Height | mm (ft-in) | 6490 (21' 4") | 6790 (22' 3") | 6760 (22' 2") | 7030 (23' 1") | 7150 (23' 5") | 7400 (24' 3") |
| E : Transport Height | mm (ft-in) | 2840 (9' 4") | 2840 (9' 4") | 2840 (9' 4") | 2840 (9' 4") | *2 2840 (9' 4") | *2 2840 (9' 4") |
| F : Overall Transport Length | mm (ft-in) | 7290 (23' 11") | 7290 (23' 11") | 7290 (23' 11") | 7290 (23' 11") | *2 7310 (24' 0") | *2 7310 (24' 0") |
| G : Minimum Swing Radius | mm (ft-in) | 1940 (6' 4") | 1940 (6' 4") | 2060 (6' 9") | 2060 (6' 9") | 2400 (7' 10") | 2400 (7' 10") |

NOTE: *1 The dimensions do not include the height of the shoe lug.

*2 The dimensions are for transport pin position.

OPTIONAL ATTACHMENTS AND DEVICES

AVOID HITTING BLADE WITH FRONT-END ATTACHMENT

When operating the machine with the blade positioned towards the front, the bucket or boom cylinder may come into contact with the blade if you are not careful. Be sure to prevent this from happening.

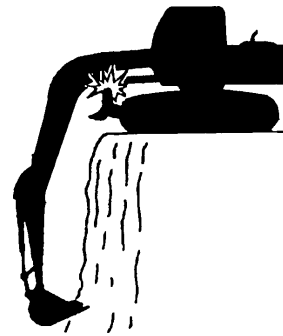

WRONG

M155-14-009

WRONG

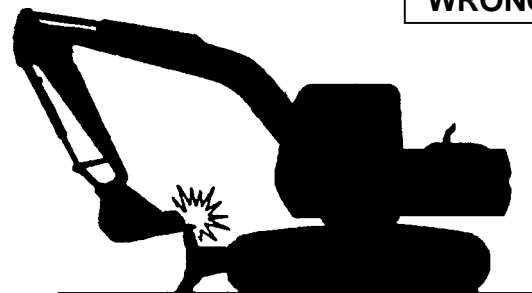

M155-14-010

AVOID HITTING BLADE WITH BUCKET

When crowding the arm into a traveling or transporting position, be careful not to let the bucket hit the blade.

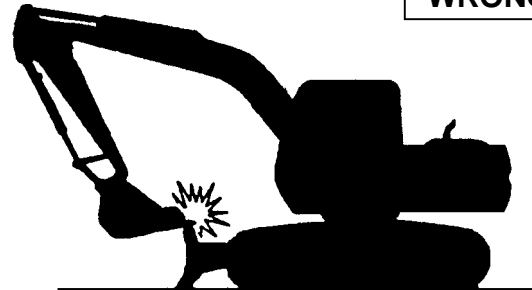

M155-14-010

AVOID STRIKING THE BLADE INTO A ROCK

Do not attempt to strike large rocks with the lade, as doing so will damage the blade and the blade cylinders, shortening their operating lives.



WRONG

M155-14-011

OPTIONAL ATTACHMENTS AND DEVICES

TRANSPORTING

Transporting



CAUTION: Fasten chains or cables to the machine frame. Do not place chains or cables over or against the hydraulic lines or hoses.

1. Place blocks in front of and behind the tracks.
2. Fasten each corner of the machine and front attachment to the trailer with a chain or cable.

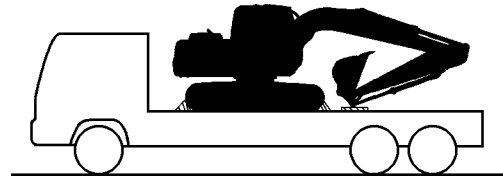

M175-13-004

PRECAUTIONS FOR TRANSPORTING MACHINES WITH RUBBER-PAD SHOES

When transporting a machine with rubber pad shoes, be sure to fasten the right and left track frames securely to the flatbed with wire ropes and soft protectors, as shown. Do not allow wire ropes to come into direct contact with rubber-covered shoes.

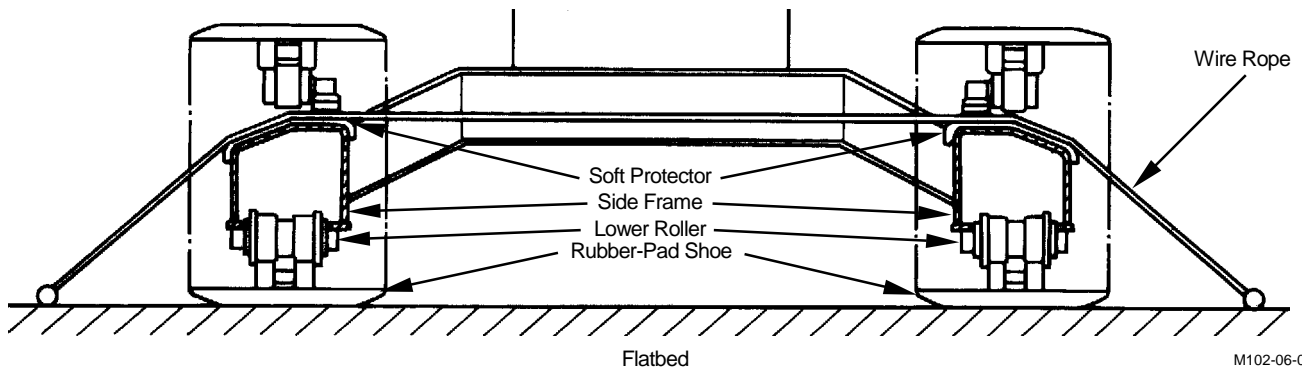

M102-06-004

OPTIONAL ATTACHMENTS AND DEVICES

LIFTING CAPACITIES

-  **NOTE:** 1. Lifting capacity of the ZX series does not exceed 75% of tipping load with the machine on firm, level ground or 87% of full hydraulic capacity. (ISO10567).
2. * Indicates load limited by hydraulic capacity.

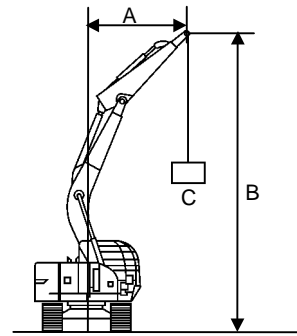













EM1SE-13-001

A : Load radius
B : Load point height
C : Lifting capacity

METRIC MEASURE













ZAXIS125US Blade (Down), Monoblock boom, Arm 1.96 m, G 500 mm

Unit: kg

| B; Load Point Height m | A: Load Radius | | | | | | | | | | | | Max. | | |
|------------------------------|---|---|---|---|---|---|---|---|---|---|---|---|------------|--------|------|
| | 1m | | 2m | | 3m | | 4m | | 5m | | 6m | | Reach m | | |
| |  |  |  |  |  |  |  |  |  |  |  |  | | | |
| 6 | | | | | 3770 * | 3770 * | 3570 * | 3570 * | | | | | 2400 * | 2400 * | 4.67 |
| 5 | | | | | 3810 * | 3810 * | 3950 * | 3950 * | 3430 * | 2780 | | | 2210 * | 2210 * | 5.49 |
| 4 | | | 6330 * | 6330 * | 5260 * | 5260 * | 4610 * | 3870 | 4140 * | 2740 | 2320 * | 2040 | 2150 * | 2020 | 6.03 |
| 3 | | | | | 7080 * | 5730 | 5320 * | 3700 | 4480 * | 2650 | 3620 * | 2010 | 2150 * | 1830 | 6.37 |
| 2 | | | | | | | 6060 * | 3510 | 4860 * | 2560 | 4180 * | 1970 | 2220 * | 1730 | 6.53 |
| 1 | | | | | | | 6550 * | 3370 | 5150 * | 2480 | 4310 * | 1920 | 2360 * | 1700 | 6.53 |
| 0 (Ground) | | | | | 4330 * | 4330 * | 6680 * | 3290 | 5260 * | 2420 | 4320 * | 1890 | 2600 * | 1740 | 6.38 |
| -1 | | | | | 6850 * | 5060 | 6460 * | 3270 | 5130 * | 2400 | 3590 * | 1890 | 2980 * | 1870 | 6.05 |
| -2 | | | 6290 * | 6290 * | 7450 * | 5110 | 5890 * | 3290 | 4630 * | 2410 | | | 3680 * | 2120 | 5.52 |
| -3 | | | 7470 * | 7470 * | 6070 * | 5210 | 4780 * | 3360 | | | | | 3730 * | 2680 | 4.72 |













ZAXIS125US Blade (Down), Monoblock boom, Arm 2.26 m, G 500 mm

Unit: kg

| B; Load Point Height m | A: Load Radius | | | | | | | | | | | | Max. | | |
|------------------------------|---|---|---|---|---|---|---|---|---|---|---|---|------------|--------|------|
| | 1m | | 2m | | 3m | | 4m | | 5m | | 6m | | Reach m | | |
| |  |  |  |  |  |  |  |  |  |  |  |  | | | |
| 6 | | | | | | | 3170 * | 3170 * | 2140 * | 2140 * | | | 2000 * | 2000 * | 5.04 |
| 5 | | | | | | | 3360 * | 3360 * | 3140 * | 2810 | | | 1860 * | 1860 * | 5.81 |
| 4 | | | 3670 * | 3670 * | 3970 * | 3970 * | 3960 * | 3910 | 3680 * | 2760 | 2730 * | 2060 | 1820 * | 1820 * | 6.32 |
| 3 | | | | | 6530 * | 5850 | 5040 * | 3740 | 4290 | 2670 | 3490 | 2020 | 1820 * | 1710 | 6.64 |
| 2 | | | | | | | 5820 | 3540 | 4710 | 2570 | 4070 | 1970 | 1880 * | 1620 | 6.80 |
| 1 | | | | | | | 6410 | 3380 | 5050 | 2480 | 4240 | 1920 | 1990 * | 1600 | 6.80 |
| 0 (Ground) | | | | | 4800 * | 4800 | 6650 | 3290 | 5230 | 2410 | 4310 | 1880 | 2180 * | 1630 | 6.66 |
| -1 | | | 3470 * | 3470 * | 6650 * | 5020 | 6540 | 3250 | 5170 | 2380 | 4170 | 1860 | 2480 | 1730 | 6.35 |
| -2 | | | 5740 * | 5740 * | 7820 * | 5060 | 6080 | 3250 | 4810 | 2380 | | | 3010 | 1940 | 5.84 |
| -3 | | | 8470 * | 8470 * | 6590 * | 5140 | 5170 | 3310 | 3860 | 2440 | | | 3700 | 2380 | 5.10 |

ZAXIS125US Blade (Down) Monoblock boom, Arm 2.81 m, G 500 mm

Unit: kg

| B; Load Point Height m | A: Load Radius | | | | | | | | | | | | | | Max. | | |
|------------------------------|---|---|---|---|---|---|---|---|---|---|---|---|---|------|------------|--------|------|
| | 1m | | 2m | | 3m | | 4m | | 5m | | 6m | | 7m | | Reach m | | |
| |  |  |  |  |  |  |  |  |  |  |  |  |  | | | | |
| 7 | | | | | | | 2530 * | 2530 * | | | | | | | 1880 * | 1880 * | 4.67 |
| 6 | | | | | | | 2610 * | 2610 * | 2420 * | 2420 * | | | | | 1690 * | 1690 * | 5.67 |
| 5 | | | | | | | 2630 * | 2630 * | 2670 * | 2670 * | 2200 * | 2110 | | | 1600 * | 1600 * | 6.36 |
| 4 | | | | | 2680 * | 2680 * | 2940 * | 2940 * | 2960 * | 2800 | 2660 * | 2090 | | | 1570 * | 1570 * | 6.83 |
| 3 | | | | | 4950 * | 4950 * | 4100 * | 3810 | 3630 * | 2700 | 3120 * | 2030 | 1940 * | 1580 | 1580 * | 1530 | 7.13 |
| 2 | | | | | 7240 * | 5580 | 5330 * | 3600 | 4390 * | 2590 | 3770 * | 1970 | 2370 * | 1550 | 1640 * | 1450 | 7.28 |
| 1 | | | | | 6370 * | 5210 | 6060 * | 3410 | 4810 * | 2480 | 4070 * | 1910 | 2600 * | 1520 | 1730 * | 1430 | 7.28 |
| 0 (Ground) | | | | | 5550 * | 5020 | 6500 * | 3280 | 5100 * | 2400 | 4230 * | 1860 | 2450 * | 1490 | 1880 * | 1450 | 7.14 |
| -1 | | | 3430 * | 3430 * | 6520 * | 4950 | 6580 * | 3210 | 5180 * | 2340 | 4230 * | 1820 | | | 2120 * | 1520 | 6.85 |
| -2 | 3850 * | 3850 * | 5060 * | 5060 * | 8330 * | 4950 | 6330 * | 3190 | 4990 * | 2330 | 3400 * | 1820 | | | 2510 * | 1670 | 6.39 |
| -3 | 5480 * | 5480 * | 7180 * | 7180 * | 7370 * | 5010 | 5690 * | 3210 | 4440 * | 2350 | | | | | 3240 * | 1970 | 5.72 |
| -4 | | | 7660 * | 7660 * | 5800 * | 5130 | 4440 * | 3300 | | | | | | | 3440 * | 2610 | 4.74 |

CLICK HERE TO **DOWNLOAD** THE COMPLETE MANUAL

- Thank you very much for reading the preview of the manual.
- You can download the complete manual from: www.heydownloads.com by clicking the link below



- Please note: If there is no response to CLICKING the link, please download this PDF first and then click on it.

CLICK HERE TO **DOWNLOAD** THE COMPLETE MANUAL