

編 番
PARTS No.
EM166-1-4

EX400₋₃ EX400LC₋₃ EX400H₋₃ EX400LCH₋₃
EXCAVATOR

Operator's Manual

適用号機
Serial No.05483～

HITACHI

CLICK HERE TO **DOWNLOAD** THE COMPLETE MANUAL

- Thank you very much for reading the preview of the manual.
- You can download the complete manual from: www.heydownloads.com by clicking the link below



- Please note: If there is no response to CLICKING the link, please download this PDF first and then click on it.

CLICK HERE TO **DOWNLOAD** THE COMPLETE MANUAL

SAFETY

WEAR PROTECTIVE CLOTHING

Wear close fitting clothing and safety equipment appropriate for the job.

Standard safety equipment includes:

- A hard hat
- Safety shoes
- Safety glasses, goggles, or face shield
- Heavy gloves
- Hearing protection
- Reflective clothing
- Wet weather clothing
- Respirator or filter mask.

Do not take chances. Wear whatever is needed for the job at hand.

Avoid wearing loose clothing, jewelry, or other items that can catch on control levers or other parts of the machine.

Operating equipment safely requires the full attention of the operator. Do not wear radio or music headphones while operating machine.

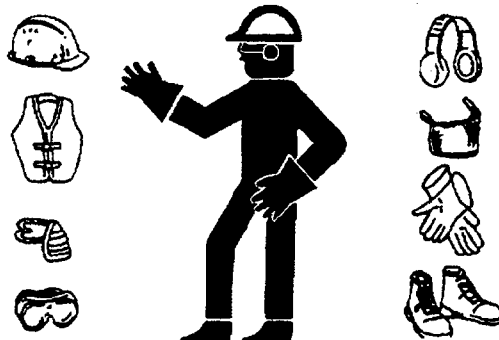

SA-023

PROTECT AGAINST NOISE

Prolonged exposure to loud noise can cause impairment or loss of hearing.

Wear a suitable hearing protective device such as earmuffs or earplugs to protect against constant or uncomfortably loud noises.



SA-024

PREPARE FOR EMERGENCIES

Be prepared if a fire starts.

Keep a first aid kit and fire extinguisher handy.

Keep emergency numbers for doctors, ambulance service, hospital, and fire department near your telephone.

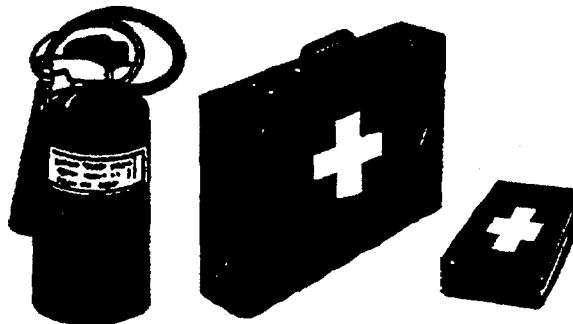

SA-020

SAFETY

PREVENT BATTERY EXPLOSIONS

Keep sparks, lighted matches, and flame away from the top of battery. Battery gas can explode.

Never check battery charge by placing a metal object across the posts. Use a voltmeter or hydrometer.

Do not charge a frozen battery; it may explode. Warm battery to 16 °C (60 °F).



SA-032

AVOID HARMFUL ASBESTOS DUST

Avoid breathing dust that may be generated when handling components containing asbestos fibers. Inhaled asbestos fibers may cause lung cancer.

Some gaskets may contain asbestos fibers. The asbestos used in these components is usually found in a resin or is sealed in some way. Normal handling is not hazardous as long as airborne asbestos-containing dust is not generated.

Avoid creating dust. Never use compressed air for cleaning. Avoid brushing or grinding asbestos containing materials. When servicing, wear an approved respirator. A special vacuum cleaner is recommended to clean asbestos. If not available, wet the asbestos-containing materials with a mist of oil or water.

Comply with all applicable workplace rules and regulations, and follow all environmental rules and regulations for the disposal of asbestos.

Keep bystanders away from the area.

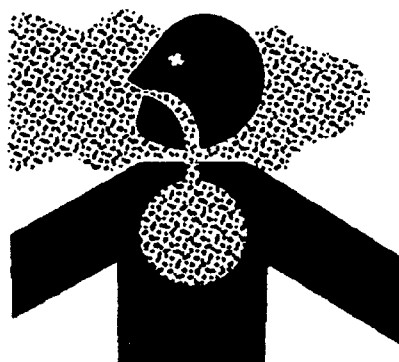

SA-029

PROTECT AGAINST FLYING DEBRIS

Guard against injury from flying pieces of metal or debris; wear goggles or safety glasses.

Keep bystanders away from the working area before striking any object, to avoid personal injury.

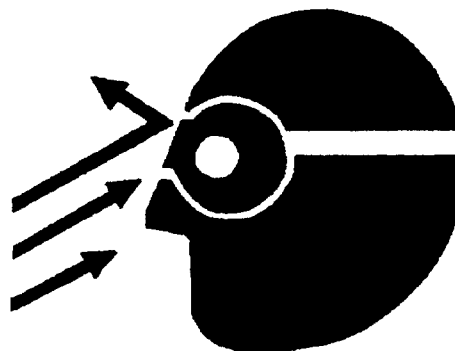

SA-022

SAFETY SIGNS

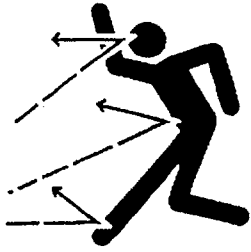

WARNING

Spring in track adjuster is loaded with great force and grease in the cylinder is under high pressure. NEVER remove grease fitting, valve assembly, or track adjuster assembly. SERIOUS PERSONAL INJURY could result. Contact your authorized dealer. Carefully read the procedures described in operator's manual before adjusting track tension and strictly comply with such procedures.

3070527

SS-408

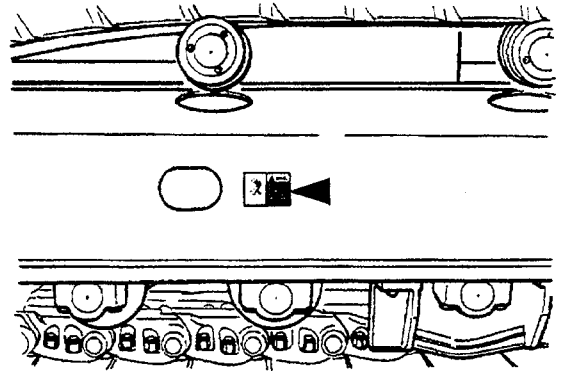

SS-551



WARNING

KEEP OFF SWING AREA

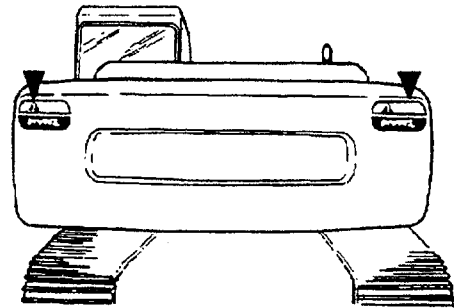

SS-442

SS-441

OPERATOR'S STATION

LIGHTS

Push switch ① once to turn on head lights ④ and instrument lights. Indicator ② will light.

Push switch ① a second time to turn on work light ⑤ and head lights ④. Indicator ③ will light.

Push switch ① a third time to turn off all lights.

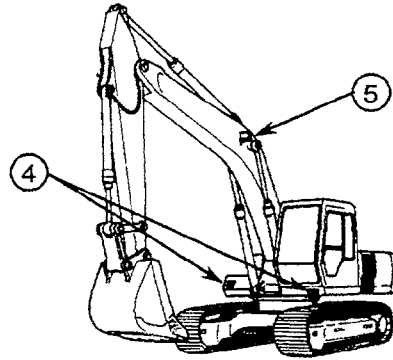

M104-01-018

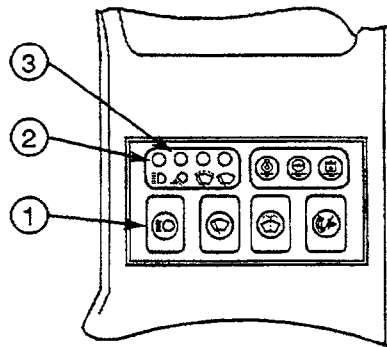

M104-01-015

KEY SWITCH

- 1 — HEAT (Pre-Heat)
- 2 — OFF (Engine Off)
- 3 — ACC (Horn, Radio etc.)
- 4 — ON (Engine On)
- 5 — START (Engine Start)

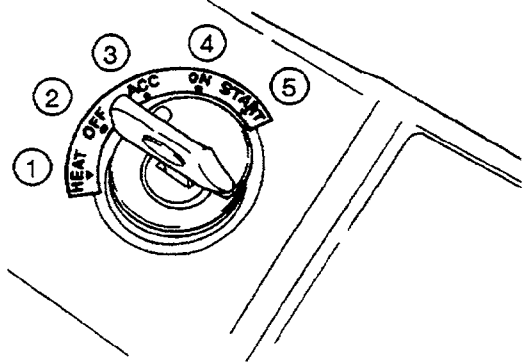

M110-01-002

OPERATOR'S STATION

4. Setting the digital clock

IMPORTANT: Clock and preset tuning buttons will need to be reset any time the machine batteries are disconnected.

- a. Select clock display by depressing display switch ⑧ and hold it.
- b. To set the clock to zero minutes press set switch ⑨ while keeping display switch ⑧ depressed. If the current minute display is 29 or less the hour display will not change, and the minute display will read 00. If the current minute display is 30 or more, the hour display will increase one hour and minute display will read 00.
- c. Keeping display switch ⑧ depressed, adjust the hour setting by depressing the (∨) side of tuning switch ③. When the correct hour is obtained, depress the (∧) side of tuning switch ③ to adjust the minute display. When the correct time is obtained, release display switch ⑧.

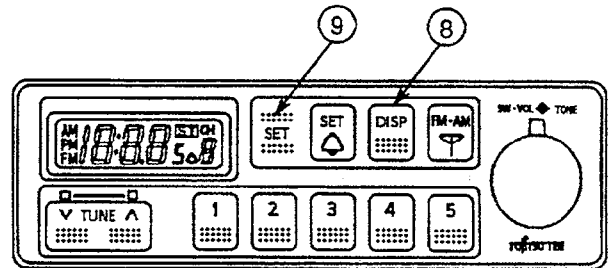

M107-01-027

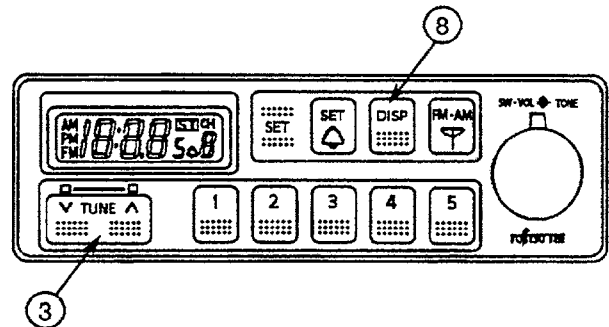

M107-01-027

OPERATOR'S STATION

ADJUSTING THE SUSPENSION SEAT (Applicable Serial No. 05598 to 05651, 05706 and up)

1. ADJUSTING THE SUSPENSION SEAT

- (1) Pull up lever ① to adjust the rear part of the seat. (5 positions in total)
- To raise the rear part of the seat, pull up lever ① and remove the body weight while seated.
 - To lower the rear part of the seat, pull up lever ① and apply the body weight to the rear part of the seat while seated.

- (2) Push down lever ② to adjust the front part of the seat. (5 positions in total)
- To raise the front part of the seat, push down lever ② and remove the body weight while seated.
 - To lower the front part of the seat, push down lever ② and apply the body weight to the front part of the seat while seated.

Adjust the seat height by adjusting the front part and the rear part alternately. Seat height adjustment range is 60 mm with steps every 15 mm (5 positions in total).

2. BACKREST ADJUSTMENT

Pull up lever ③ to release the backrest lock. From the upright position, the backrest can be lowered 66 degrees forward and 72 degrees backward with stops every 3 degrees. Note that the backrest may hit against your back when lever ③ is pulled if you are seated with your back positioned away from the backrest. When adjusting the backrest angle while seated, be sure that your back always makes contact with the backrest.

3. SEAT FORE-AFT ADJUSTMENT

Pull up handle ④ to slide the seat to the desired position. Note that the fore-aft seat adjustment range is 160 mm with stops every 10 mm. (17 positions in total)

4. WEIGHT ADJUSTMENT

Turn weight adjustment knob ④ until the needle indicates your weight. Turn the knob clockwise to increase the weight indication and counterclockwise to decrease the weight indication.

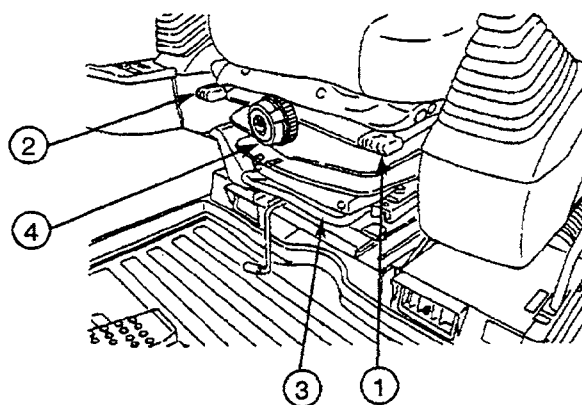

M116-01-018

DRIVING THE MACHINE

DRIVE THE MACHINE CAREFULLY

IMPORTANT: During freezing weather, park machine on a hard surface to prevent tracks from freezing to the ground. Clean debris from tracks and track frame.

If tracks are frozen to the ground, raise tracks using boom, move machine carefully to prevent damage to drive train and tracks.

If engine stops under load, remove load. Start engine immediately. Run engine 30 seconds in light duty (L) mode before you add load.

Select a route that is as flat as possible. Steer machine as straight as possible making small, gradual changes in direction.

When driving over rough terrain, reduce engine speed to lessen possibility of undercarriage damage.

OPERATING THE MACHINE

AUTO-IDLE SWITCH

The auto-idle device automatically reduces engine speed after a few seconds when all control levers are placed in neutral, in order to save fuel.

CAUTION: Unexpected machine movement can cause serious personal injury. Turn auto-idle switch off when automatic acceleration/deceleration of engine speed is not desired and when stopping engine.

Always check the auto-idle switch before operating any control levers. When ON and with the power mode select switch in P, E, or L mode, the engine speed lowers to auto-idle speed approximately 4 to 6 seconds after the control levers are returned to neutral.

Always make sure the auto-idle switch is OFF when loading or unloading the machine, as the engine speed will increase to power mode select switch setting (PEL) if any control lever is accidentally operated while the auto-idle switch is ON.

Push auto-idle switch ① to turn circuit on. Auto-idle indicator ② will light.

If the engine is started with auto-idle switch ① on and the power mode select switch in P, E, or L mode, the engine will run at auto-idle setting after approximately 4 to 6 seconds.

Engine speed will change to power mode selector setting if any control lever is operated.

If the engine is started with the auto-idle switch off, the engine will run at the power mode selector setting.

Auto-idle function is backed up by batteries. If the engine is stopped by turning off the key switch while auto-idle function is in operation, the function will re-engage when the engine is started again.

Push the auto-idle switch off to improve machine control in difficult work areas, and while loading/unloading.

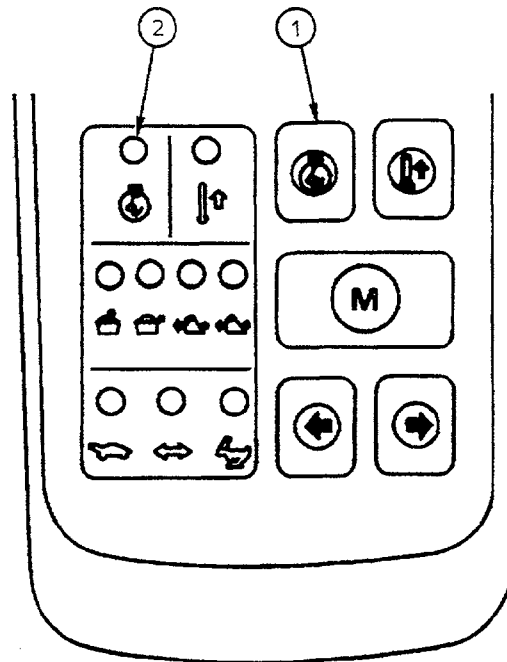

M111-05-004

OPERATING THE MACHINE

TOWING MACHINE A SHORT DISTANCE

⚠ CAUTION: Cables, straps, or ropes can break causing serious injury. Do not tow machine with damaged chains, frayed cables, slings, straps, or ropes.

Always wear gloves when handling cable, straps or ropes.

When your machine becomes stuck but the engine is still operational, attach wire rope tow lines as illustrated at right, and slowly tow your machine to firm ground using another machine.

Be sure to attach the wire ropes around the track frames of both machines as illustrated.

To prevent the wire ropes from being damaged, place some protective material between the track frame and the wire ropes.

IMPORTANT: 1. Slowly tow, keeping the tow line horizontal and in a straight line with the tracks.

2. When the machine is towed, release parking brakes by operating the travel levers.

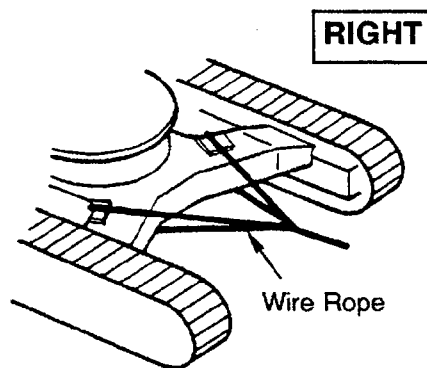

M104-05-010

TRANSPORTING

6. Pull pilot control shut-off lever to LOCK position.
7. Close cab windows, roof vent and door, and cover the exhaust opening, to prevent entry of wind and water.

NOTE: In cold weather, be sure to warm up the machine before loading or unloading it.

Transporting

CAUTION: Fasten chains or cables to the machine frame. Do not place chains or cables over or against the hydraulic lines or hoses.

1. Place blocks in front of and behind the tracks.
2. Fasten each corner of the machine and front attachment to the trailer with a chain or cable.



M111-06-029

Unloading

CAUTION: The rear end of the flatbed where it meets the ramp is a sudden bump. Take care when traveling over it.

IMPORTANT: Prevent possible damage to the front attachment. Always position the arm at 90° to the boom when unloading the machine. Unloading the machine with the arm tucked in may cause machine damage.

1. To move the machine over end of the trailer onto the ramp, rest the flat surface of the tip of arm on the ground. Angle of the arm to the boom should be 90 to 110°.

IMPORTANT: Prevent possible damage to the hydraulic cylinders. Do not allow the machine to hit ground hard with the arm.

2. The tip of arm must be on the ground before the machine begins to tip forward.
3. As the machine moves forward, raise the boom and extend the arm until the machine is completely off the ramp.

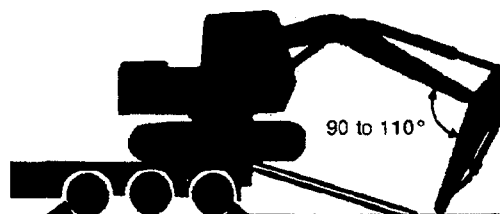

M111-06-030



M111-06-031

TRANSPORTING

Counterweight

Weight: 8 800 kg (19 400 lb)
 Maximum Height: 1 249 mm (4 ft 1 in)

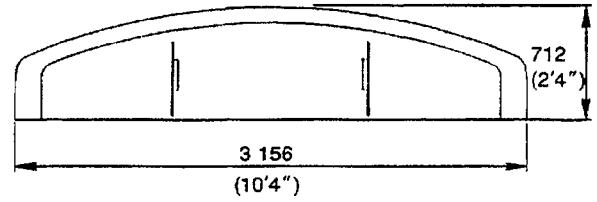

M111-06-005

Side Step

Weight: 30 kg (66 lb)
 Maximum Height: 146 mm (6 in)

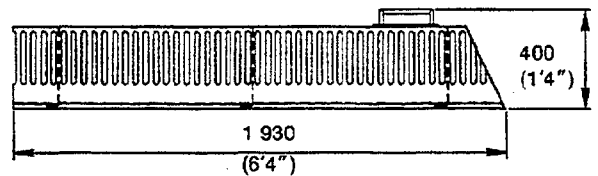
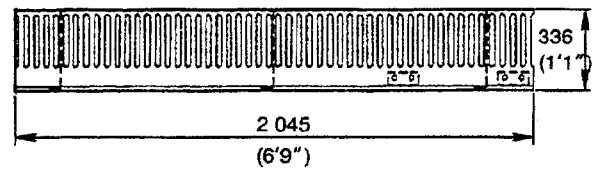

M111-06-002

Packing Dimensions and Weights for Transportation - 3

Basic Machine

Weight : 30 300 kg (66 800 lb)

Shoe Width mm (ft-in)	Overall Width mm (ft-in)	Weight kg (lb)
600 (2'0")	3 156 (10'4")	30 300 (66 800)
750 (2'6")	3 178 (10'5")	31 400 (69 200)

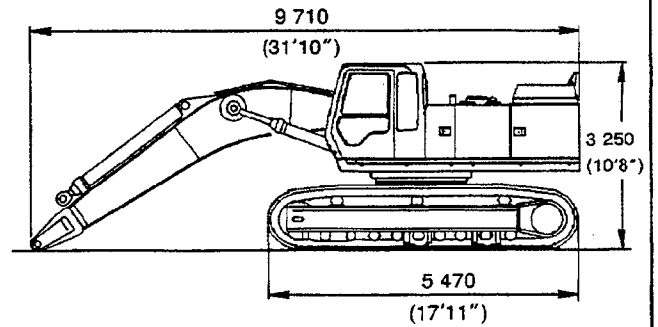

M111-06-019

Arm and Bucket

Arm Length mm (ft-in)	Bucket Capacity (PCSA heaped) m ³ (yd ³)	A mm (ft-in)	B mm (ft-in)	Overall Width mm (ft-in)	Weight kg (lb)
2 900 (9'6")	2.07 (2.71)	6 030 (19'9")	1 340 (4'5")	1 660 (5'5")	4 000 (8 820)
3 400 (11'2")	1.82 (2.38)	6 430 (21'1")	1 270 (4'2")	1 630 (5'4")	3 900 (8 600)
3 900 (12'10")	1.60 (2.09)	6 930 (22'9")	1 270 (4'2")	1 500 (4'11")	4 000 (8 280)
4 900 (16'1")	1.36 (1.78)	7 760 (25'6")	1 170 (3'10")	1 410 (4'8")	3 500 (7 720)

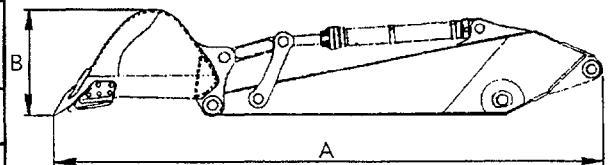

M111-06-007

CLICK HERE TO **DOWNLOAD** THE COMPLETE MANUAL

- Thank you very much for reading the preview of the manual.
- You can download the complete manual from: www.heydownloads.com by clicking the link below



- Please note: If there is no response to CLICKING the link, please download this PDF first and then click on it.

CLICK HERE TO **DOWNLOAD** THE COMPLETE MANUAL

TRANSPORTING

15. Remove both lock pins ③ from nut ② on bolts ①.

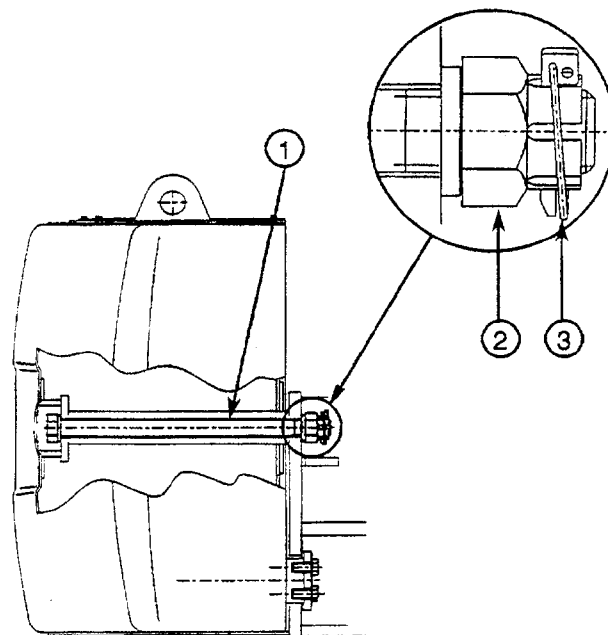

M116-06-024

16. Open the left rear access door and pull off lever cover ④ of counterweight pilot control valve ⑤.

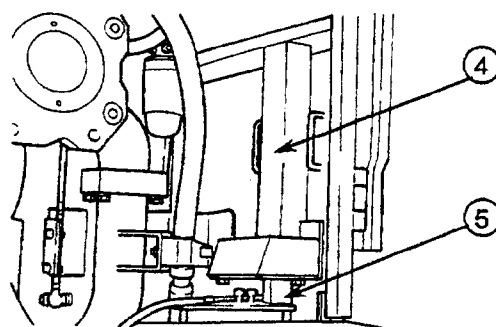

M111-06-024

17. Start the engine. Run machine in "precision" work mode ⑦ and "1" (low idle) power mode ⑥.

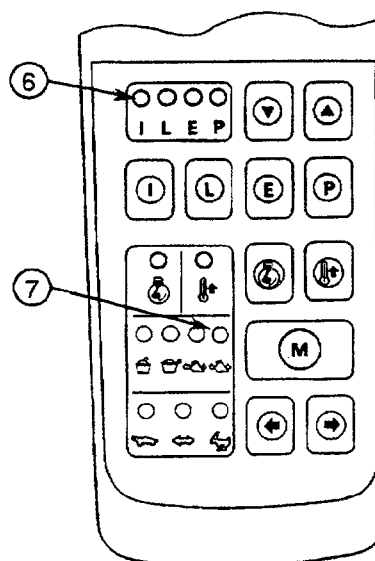

M104-01-020

MAINTENANCE

PREPARE MACHINE FOR MAINTENANCE

Before performing the maintenance procedures given in the following chapters, park the machine as described below, unless otherwise specified.

1. Park the machine on a level surface.
2. Lower the bucket to the ground.
3. Turn the auto-idle switch off.

IMPORTANT: The turbocharger may be damaged if the engine is not properly shut down.

4. Run the engine at slow idle speed without load for three minutes.
5. Turn the key switch OFF. Remove key from switch. (If maintenance must be performed with engine running, do not leave machine unattended.)
6. Pull the pilot control shut-off lever to the LOCK position.
7. Before performing any work on the machine, attach a "Do Not Operate" tag on the right control lever.

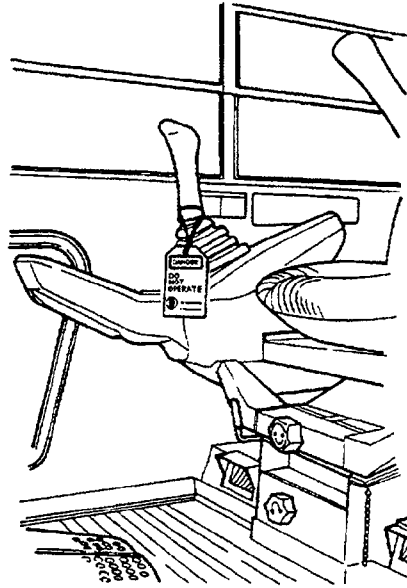

SA-109

OPEN ACCESS DOORS FOR SERVICE

To hold door open, remove rod from stored position ① and insert it in tab ②.

A tool box is provided in the right front compartment.

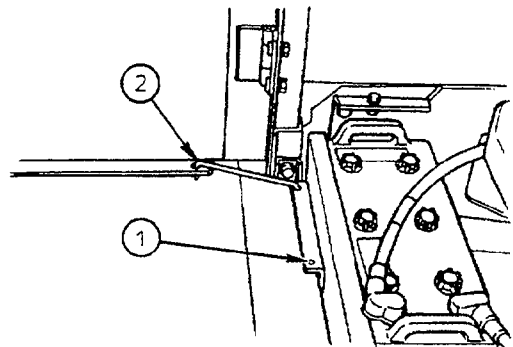

M111-07-003

MAINTENANCE

LUBRICATOR --- IF EQUIPPED

1. Lubricator Operation

- (1) Turn power switch ⑧ ON to activate the pump.
Grease is sucked up and supplied to high-pressure grease gun ③.

IMPORTANT: When the pump begins to suck grease, any air inside pump ① will be mixed in, making grease turn whitish. Open check valve cock ② to bleed this air-mixed grease. Securely close check valve cock ② when all air-mixed grease is bled out.

- (2) Grab high-pressure grease gun ③ and pay out the hose from hose reel ④ to the length required.
- (3) Press hydro-chuck ⑤ protruding from high-pressure grease gun ③ into a grease nipple and pull the lever to discharge grease.
- (4) Release the lever when greasing is complete; grease discharge will stop.

IMPORTANT: When detaching hydro-chuck ⑤ from grease nipple ⑦, grease nipple ⑦ tip may break unless a special care, is taken, as follows:

- Tip nozzle ⑥ a little so as to release the connecting pressure applied to hydro-chuck ⑤.
- Slowly detach hydro-chuck ⑤ from grease nipple ⑦.

- (5) When all greasing work is complete, turn power switch ⑧ OFF, then pull grease gun lever to release remaining pressure from grease gun ③, pump ①, and the hose so as to ensure long life of the components. A little grease will be discharged at this time.

NOTE: The hose has a limited service life. Periodically inspect the hose for cracks, grease leakage, or any other damage. If any damage is found, replace the hose in good time.

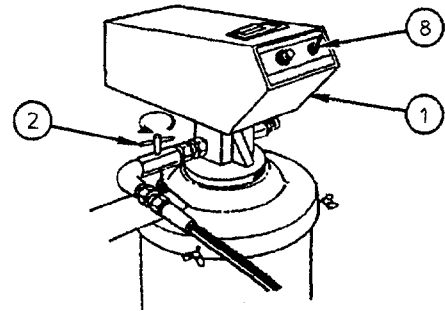

M111-07-114

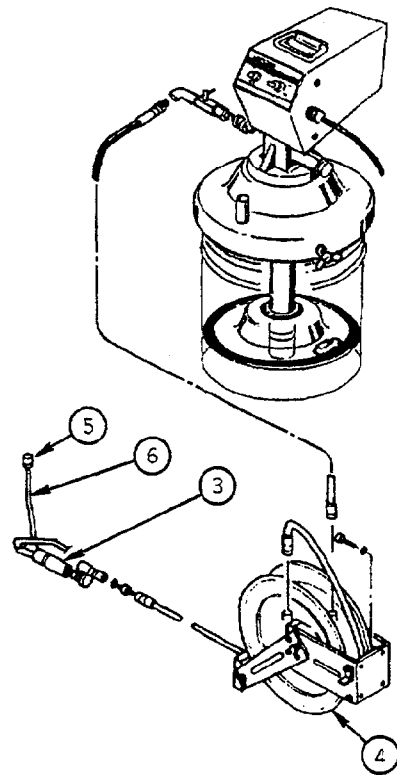

M111-07-115

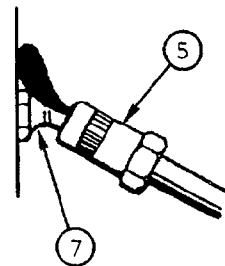

M111-07-013

MAINTENANCE

1 Swing Reduction Gear

Check Oil Level — every 250 hours

1. Park the machine on a level surface.
2. Lower the bucket to the ground.
3. Turn the auto-idle switch off.

IMPORTANT: The turbocharger may be damaged if the engine is not properly shut down.

4. Run the engine at slow idle speed without load for three minutes.
5. Stop the engine. Remove the key from the key switch.
6. Pull the pilot control shut-off lever to the LOCK position.

CAUTION: Gear oil may be hot. Wait for gear oil to cool before starting work.

7. Remove dipsticks ①. Oil must be between marks.
8. If necessary, remove oil supply caps ② and add oil. (See gear oil chart)
9. Recheck oil level.

Change Gear Oil — every 1 000 hours

1. Park the machine on a level surface.
2. Lower the bucket to the ground.
3. Turn the auto-idle switch off.

IMPORTANT: The turbocharger may be damaged if the engine is not properly shut down.

4. Run the engine at slow idle speed without load for three minutes.
5. Stop the engine. Remove the key from the key switch.
6. Pull the pilot control shut-off lever to the LOCK position.

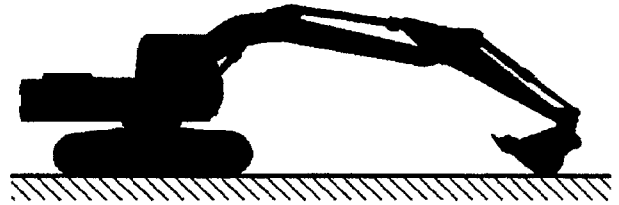

M104-07-021

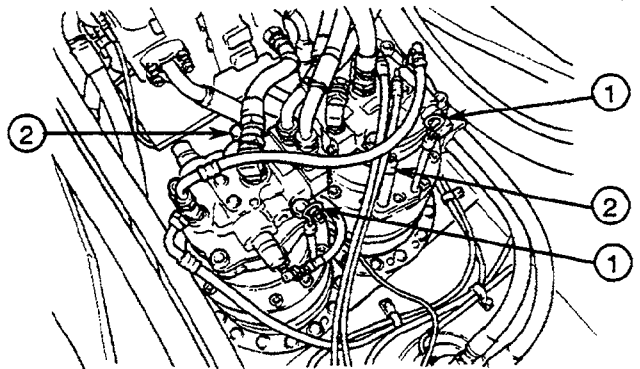

M111-07-106

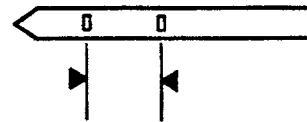

M104-07-017

MAINTENANCE

5 Replace Hydraulic Oil Tank Filter -- every 500 hours

1. Park the machine on a level surface.
2. Lower the bucket to the ground.
3. Turn the auto-idle switch off.

IMPORTANT: The turbocharger may be damaged if the engine is not properly shut down.

4. Run the engine at slow idle speed without load for three minutes.
5. Stop the engine. Remove the key from the key switch.
6. Pull the pilot control shut-off lever to the LOCK position.

⚠ CAUTION: Keep body and face away from cap ⑦. Turn cap ⑦ slowly and remove the cap only after releasing the internal pressure completely.

7. Insert the wrench as shown and turn the wrench clockwise and hold the wrench.
8. Turn cap ⑦ counter-clockwise about 30°, at which point stop cap ⑦ to release the air.
9. Turn cap ⑦ further and remove cap ⑦.
10. Align the projected part of cap ⑦ with the projected part of the case and install cap ⑦.

NOTE: There is spring tension under the cover. Hold down the cover when removing last two bolts.

11. Hold down filter cover ② against light spring load when removing the last two bolts. Remove filter cover ②.
12. Remove spring ④, valve ⑤ and element ⑥.
13. Discard element ⑥ and O-ring ③.
14. Install a new element, valve and spring.
15. Install cover ② with new O-ring ③.
16. Install and tighten bolts ① to 49 N·m (5 kgf·m, 36 lbf·ft).

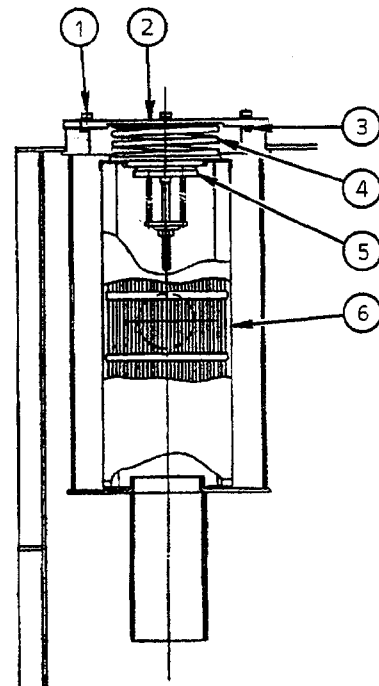

M111-07-040

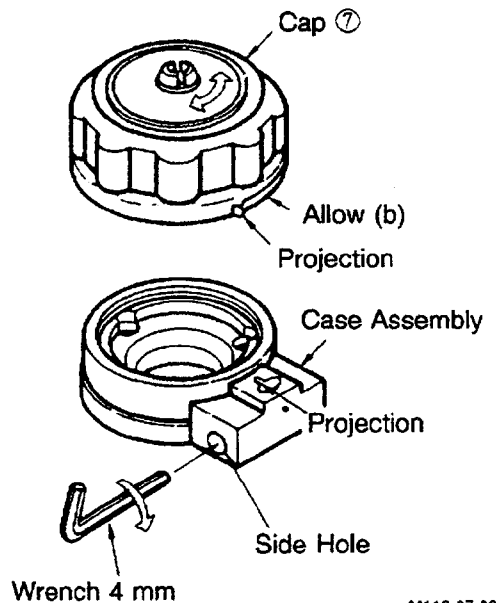

M110-07-022

MAINTENANCE

Bleed Air from Fuel System

IMPORTANT: Air in the fuel system may make the engine hard to start or make it run irregularly. After draining water and sediment from the water separator, replacing the fuel filter, cleaning the feed pump strainer or running the fuel tank dry, be sure to bleed the air from the fuel system.

1. Confirm that drain plug ④ and air bleed plug ① on water separator ③ is tight. If air bleed plug ① is not tight air will not bleed from the fuel system.
2. Loosen air bleed plug ② on the fuel filter.
3. Loosen fuel feed pump ⑤ knob, raise and lower the plunger until no more air bubbles can be seen in the fuel.
4. Tighten air bleed plug ② on the fuel filter plunger. Raised and lower the plunger until the load become heavy.
5. Push fuel feed pump ⑤ knob down and tighten.
6. Start the engine and run at slow idle.
7. Put a "Do Not Operate" tag on the right control lever.
8. Pull the pilot control shut-off lever to the LOCK position.
9. Inspect the fuel system for leaks.

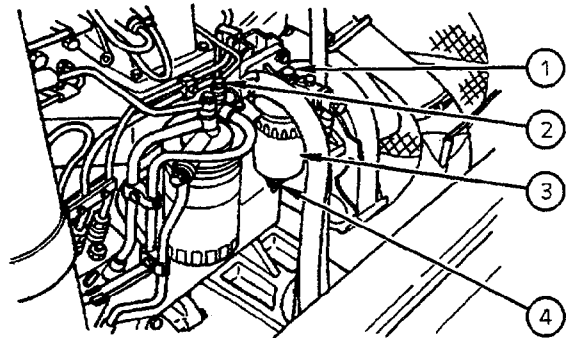

M111-07-045

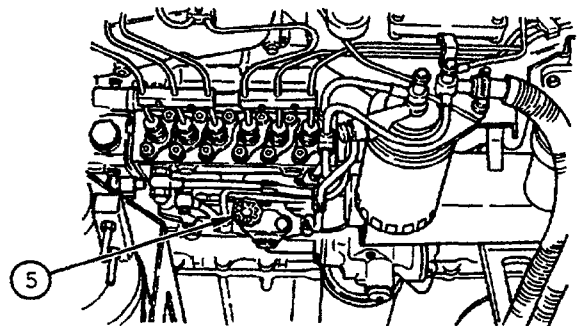

M111-07-046

MAINTENANCE

2

Ventilation Air Filter (Only the EX400H-3 and EX400LCH-3 are provided.)

Clean Air Filter --- every 50 hours

- (1) Clogging of the air filter at the outer air suction port reduces cooling ability of the air conditioner.
- (2) Open cover ① behind the cab.
- (3) Loosen bolts ② to remove element dust cover ③.
- (4) Loosen nuts ⑦ to remove cover ⑥. Then, remove ventilation air filter ⑤ in air box ④.
- (5) Use compressed air pressure to clean the air filter.



CAUTION: When using compressed air pressure, be sure to wear safety glasses or goggles.

Replace Air Filter --- every 1 000 hours

IMPORTANT: Replacement interval of the air filter must be changed depending on the work site environment conditions. If the air filter is contaminated or clogged heavily, cleaning of the air filter may have no effect to resume cooling ability of the air conditioner. Replace the filter at a shorter interval in such cases.

- (1) Open cover ① behind the cab.
- (2) Loosen bolts ② to remove element dust cover ③.
- (3) Loosen nuts ⑦ to remove cover ⑥. Then, replace ventilation air filter ⑤ in air box ④.

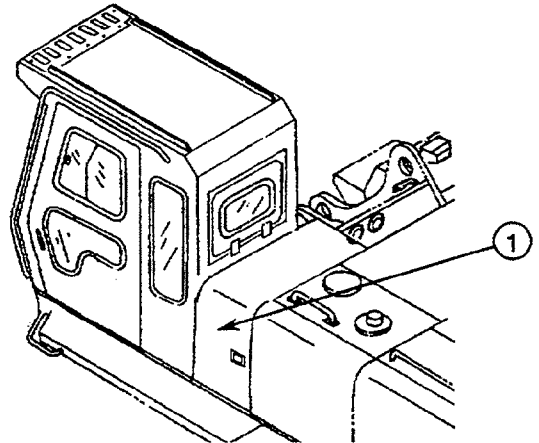

M116-07-114

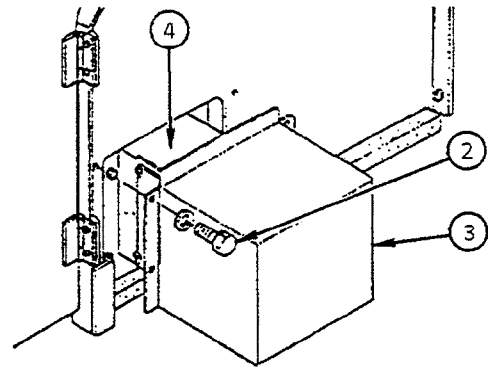

M116-07-015

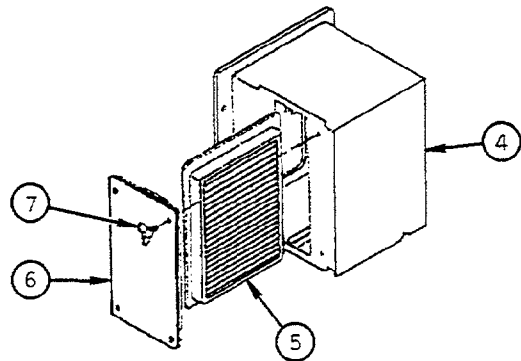

M116-07-016

MAINTENANCE

- d. Install rubber pin lock ④ into shank ⑥ hole as shown.

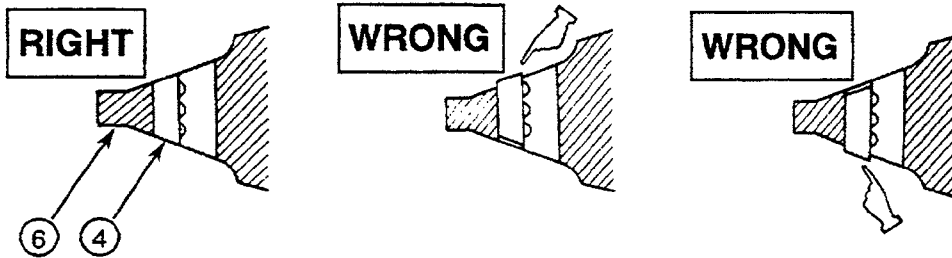

M104-07-060

- e. Position new tooth ① over shank ⑥.

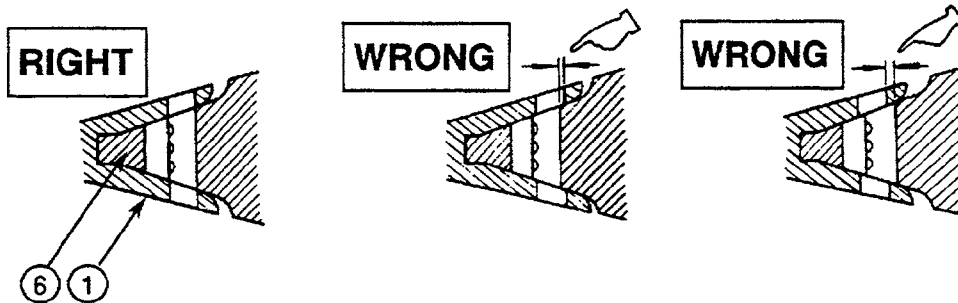

M104-07-061

- f. Drive locking pin ⑤ into the hole fully as shown.

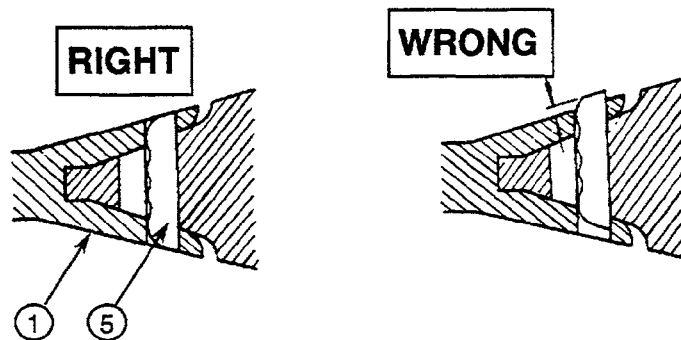

M104-07-062

NOTE: Check the bucket teeth periodically to ensure that wear does not exceed the designed service limit.

MAINTENANCE

Loosen the Track

- CAUTION:** Do not loosen valve ① quickly or loosen it too much as high-pressure grease in the adjusting cylinder may spout out. Loosen carefully, keeping body parts and face away from valve ①.
Never loosen grease fitting ②.

IMPORTANT: When gravel or mud is packed between sprockets and track links, remove it before loosening.

1. To loosen the track, slowly turn valve ① counterclockwise using long socket 24; grease will escape from the grease outlet.
2. Between 1 to 1.5 turns of valve ① is sufficient to loosen the track.
3. If grease does not drain smoothly, slowly rotate the raised track.
4. When proper track sag is obtained, turn valve ① clockwise and tighten to 147 N·m (15 kgf·m, 108 lbf·ft).

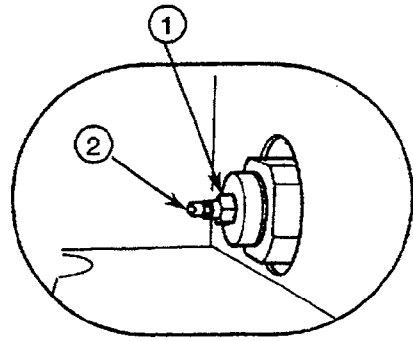

M116-07-093

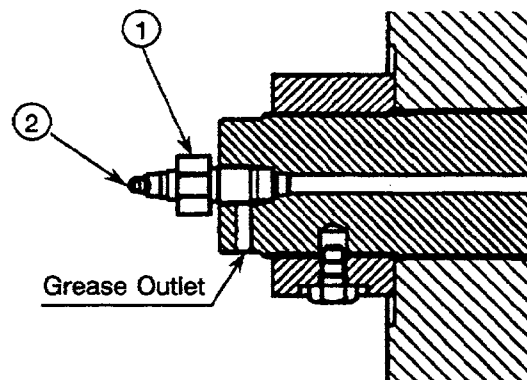

M116-07-094

Tighten the Track

- CAUTION:** It is abnormal if the track remains tight after turning valve ① counterclockwise or if the track is still loose after charging grease to fitting ②. In such cases, **NEVER ATTEMPT TO DISASSEMBLE** the track shoes or track adjuster, because of dangerous high-pressure grease inside the track adjuster. See your authorized dealer immediately.

To tighten the track, connect a grease gun to grease fitting ② and add grease until the sag is within specifications.

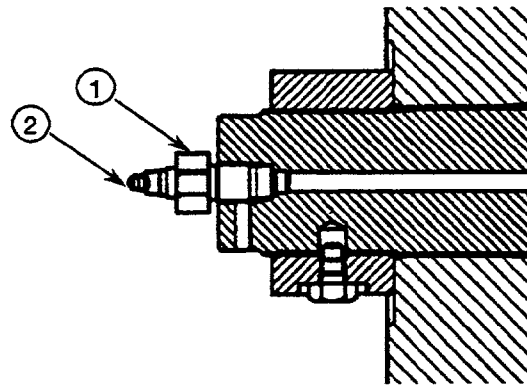

M116-07-094

Replace the Track

- CAUTION:** Special training and expertise are needed to replace the track. **NEVER ATTEMPT** to replace the track yourself. Be sure to ask your authorized dealer for track replacement.

MAINTENANCE

Retighten front pin-retaining nuts.

Tool : 30 mm

Torque : 390 N·m (40 kgf·m, 290 lbf·ft)

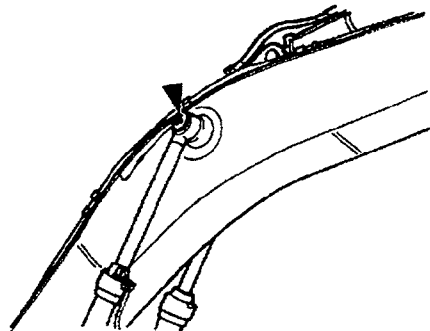

M111-07-085

Tool : 30 mm

Torque : 390 N·m (40 kgf·m, 290 lbf·ft)

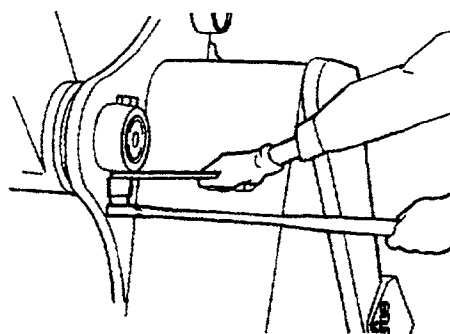

M111-07-086

TROUBLESHOOTING

ELECTRICAL SYSTEM

Problem	Cause	Solution
Nothing Works	Battery	Recharge or replace.
Nothing Works (Except clock)	Battery relay	Replace relay.
Batteries Undercharged	Loose or corroded connections	Clean and tighten or replace batteries.
	Alternator belt loose	Tighten or install new belt.
	Alternator not charging	See your authorized dealer.
	Fuse	Replace fuse.
	Key switch failure	Replace key switch.
Starting Motor Will Not Turn	Battery undercharged or dead	Recharge or replace battery.
	Battery cables making poor connections	Clean connections.
	Fusible link	Replace fusible link.
	Key switch	See your authorized dealer.
	Start relay	See your authorized dealer.
	Starter solenoid	See your authorized dealer.
	Starter	Repair or replace start motor.
	Starter pinion jammed in flywheel gear	Repair or replace starter.
	Major engine failure	See your authorized dealer.
Starter Solenoid Chatters	Poor connections at batteries or starter	Clean connections.
	Low battery charge	Recharge or replace batteries.
	Starter solenoid "hold-in" windings open	See your authorized dealer.
Starter Motor Turn But Will Not Crank Engine	Starter pinion gear not engaging flywheel ring gear	See your authorized dealer.
	Pinion shift mechanism jammed or malfunctioning	See your authorized dealer.
	Pinion gear teeth broken	See your authorized dealer.
	Flywheel gear teeth broken	See your authorized dealer.
Engine Cranks Slowly	Battery cables damaged or broken internally	Inspect and replace cables.
	Battery or starter cable connections loose or corroded	Clean and tighten connections.

SPECIFICATIONS

SHOE TYPES AND APPLICATIONS

EX400-3

Shoe Width mm (in)		600 mm (24") Grouser Shoe	750 mm (30") Grouser Shoe
Application		For Ordinary Ground (Standard)	For Weak Footing (Option)
Operating Weight	kg (lb)	41 000 (90 400)	42 000 (92 600)
Basic Machine Weight	kg (lb)	32 200 (71 000)	33 200 (73 200)
Cab Height	mm (ft-in)	3 130 (10'3")	3 130 (10'3")
Minimum Ground Clearance	mm (ft-in)	*496 (20")	*496 (20")
Undercarriage Length	mm (ft-in)	5 050 (16'7")	5 050 (16'7")
Undercarriage Width	mm (ft-in)	3 340 (11'0")	3 490 (11'5")
Ground Pressure		74 kPa (0.75 kgf/cm ² , 10.7 psi)	63 kPa (0.64 kgf/cm ² , 9.1 psi)

EX400LC-3

Shoe Width mm (in)		600 mm (24") Grouser Shoe	750 mm (30") Grouser Shoe
Application		For Ordinary Ground (Standard)	For Weak Footing (Option)
Operating Weight	kg (lb)	43 000 (94 800)	44 100 (97 200)
Basic Machine Weight	kg (lb)	34 200 (75 400)	35 300 (77 800)
Cab Height	mm (ft-in)	3 250 (10'8")	3 250 (10'8")
Minimum Ground Clearance	mm (ft-in)	*735 (29")	*735 (29")
Undercarriage Length	mm (ft-in)	5 470 (17'11")	5 470 (17'11")
Undercarriage Width (Extended/Retracted)	mm (ft-in)	3 490/2 990 (11'5")/(9'10")	3 640/3 140 (11'11")/(10'4")
Ground Pressure		72 kPa (0.73 kgf/cm ² , 10.4 psi)	60 kPa (0.61 kgf/cm ² , 8.7 psi)

NOTE: (1) The specifications for the front-end attachment are for 2.9 m (9 ft 6 in) arm or 3.4 m (11 ft 2 in) arm with PCSA 1.82 m³ (2.38 yd³) bucket.
 (2) 750 mm (30 in) grouser shoe should not be used on gravel or rocky ground.

(3) * The dimensions do not include the height of the shoe lug.

CLICK HERE TO **DOWNLOAD** THE COMPLETE MANUAL

- Thank you very much for reading the preview of the manual.
- You can download the complete manual from: www.heydownloads.com by clicking the link below



- Please note: If there is no response to CLICKING the link, please download this PDF first and then click on it.

CLICK HERE TO **DOWNLOAD** THE COMPLETE MANUAL