

# Operator's Manual

## ZAXIS

**130W**

**160W**

**180W**

**210W**

# Wheel Excavator

Serial No.

ZX130W 001001 and up

ZX160W 002001 and up

ZX180W 001001 and up

ZX210W 001001 and up

# HITACHI

CLICK HERE TO **DOWNLOAD** THE COMPLETE MANUAL

- Thank you very much for reading the preview of the manual.
- You can download the complete manual from: [www.heydownloads.com](http://www.heydownloads.com) by clicking the link below



- Please note: If there is no response to CLICKING the link, please download this PDF first and then click on it.

CLICK HERE TO **DOWNLOAD** THE COMPLETE MANUAL

# SAFETY

## RECOGNIZE SAFETY INFORMATION

- These are the **SAFETY ALERT SYMBOLS**.
  - When you see these symbols on your machine or in this manual, be alert to the potential for personal injury.
  - Follow recommended precautions and safe operating practices.

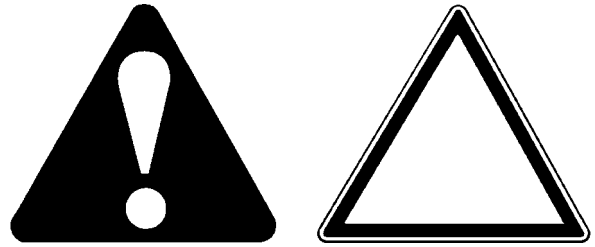

SA-688

001-E01A-0001

## UNDERSTAND SIGNAL WORDS

- On machine safety signs, signal words designating the degree or level of hazard - **DANGER**, **WARNING**, or **CAUTION** - are used with the safety alert symbol.
  - **DANGER** indicates an imminently hazardous situation which, if not avoided, will result in death or serious injury.
  - **WARNING** indicates a potentially hazardous situation which, if not avoided, could result in death or serious injury.
  - **CAUTION** indicates a potentially hazardous situation which, if not avoided, may result in minor or moderate injury.
  - **DANGER** or **WARNING** safety signs are located near specific hazards. General precautions are listed on **CAUTION** safety signs.
  - Some safety signs don't use any of the designated signal words above after the safety alert symbol are occasionally used on this machine.



**IMPORTANT**



SA-1223

- **CAUTION** also calls attention to safety messages in this manual.
- To avoid confusing machine protection with personal safety messages, a signal word **IMPORTANT** indicates a situation which, if not avoided, could result in damage to the machine.
-  **NOTE** indicates an additional explanation for an element of information.

002-E01A-1223

## SAFETY

### AVOID INJURY FROM ROLLAWAY ACCIDENTS

- Death or serious injury may result if you attempt to mount or stop a moving machine.

To avoid rollaways:

- Select level ground when possible to park machine.
- Do not park the machine on a grade.
- Lower the bucket and/or other work tools to the ground.
- Place the shift lever in neutral, and put the brake switch in the P (parking brake) position.
- Turn the auto-idle switch off.
- Run the engine at slow idle speed without load for 5 minutes to cool down the engine.
- Stop the engine and remove the key from the key switch.
- Pull the pilot control shut-off lever to LOCK position.
- Block both tires and lower the bucket to the ground. Thrust the bucket teeth into the ground if you must park on a grade.
- Position the machine to prevent rolling.
- Park a reasonable distance from other machines.

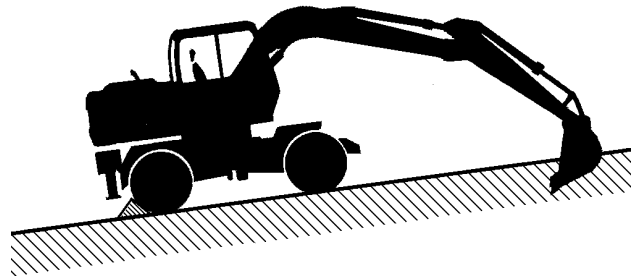
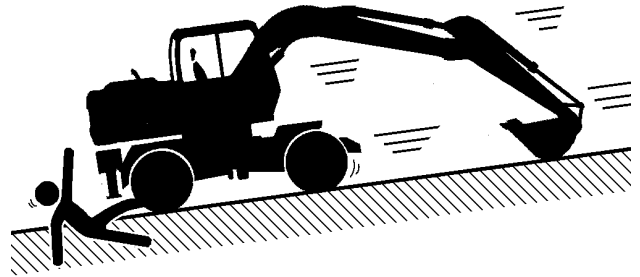

SA-278

020-E01A-0270

## SAFETY

---

### PREVENT PARTS FROM FLYING

- Travel reduction gears are under pressure.
  - As pieces may fly off, be sure to keep body and face away from AIR RELEASE PLUG to avoid injury. GEAR OIL is hot.
  - Wait for GEAR OIL to cool, then gradually loosen AIR RELEASE PLUG to release pressure.



503-E03A-0344

SA-344

### STORE ATTACHMENTS SAFELY

- Stored attachments such as buckets, hydraulic hammers, and blades can fall and cause serious injury or death.
  - Securely store attachments and implements to prevent falling. Keep children and bystanders away from storage areas.

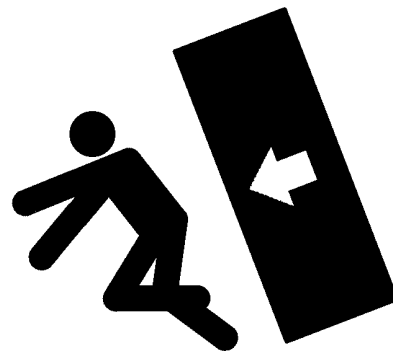

504-E01A-0034

SA-034

### SUPPORT MAINTENANCE PROPERLY

- Explosive separation of a tire and rim parts can cause serious injury or death.
  - Do not attempt to mount a tire unless you have the proper equipment and experience to perform the job. Have it done by your authorized dealer or a qualified repair service.
  - Always maintain the correct tire pressure. DO NOT inflate tire above the recommended pressure.
  - When inflating tires, use a chip-on chuck and extension hose long enough to allow you to stand to one side and not in front of or over the tire assembly. Use a safety cage if available.
  - Inspect tires and wheels daily. Do not operate with low pressure, cuts bubbles, damaged rims, or missing lug bolts and nuts.
  - Never cut or weld on an inflated tire or rim assembly. Heat from welding could cause an increase in pressure and may result in tire explosion.

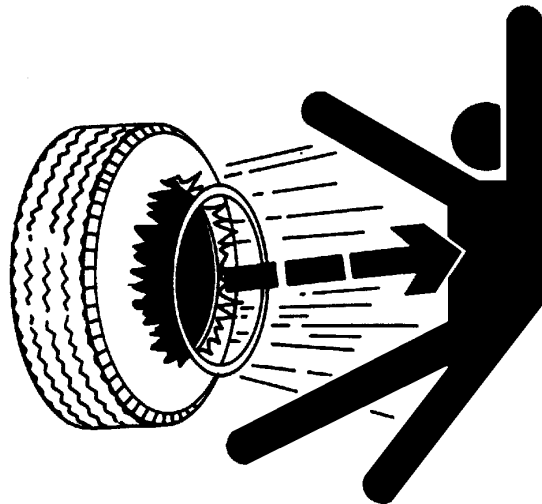

521-E02A-0249

SA-249

## SAFETY SIGNS/Europe/Asia/Middle and Near East Model Only

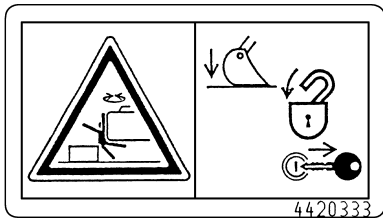

SS4420333

Caution: If the parked machine is unexpectedly moved, serious injury or death due to crushing may result. Be sure to lower the front attachment to the ground, lock the control levers, and remove the engine key before leaving the machine unattended.

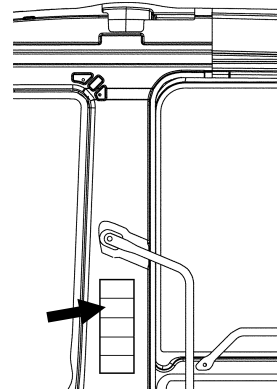

SS-2451

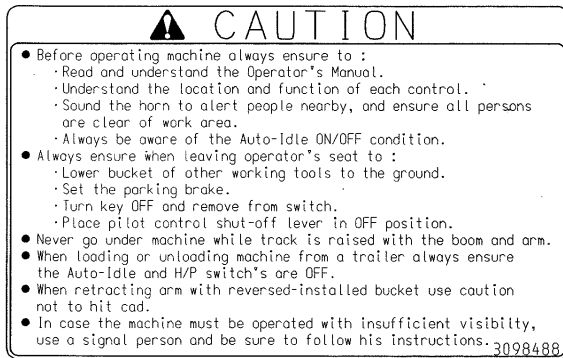

SS3098488

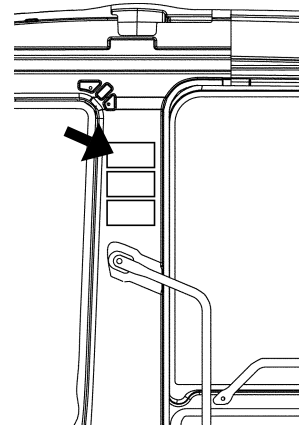

SS-2455



SS3089581

- Sign indicates a hazard of being hit by the working device of the machine.  
Keep away from machine during operation.

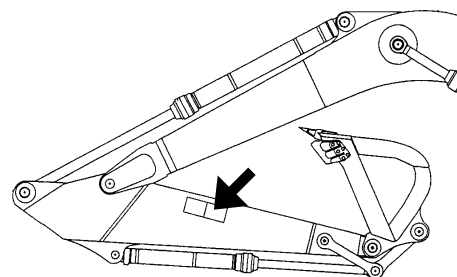

SS-2042

# OPERATOR'S STATION

## BRAKE PEDAL



**CAUTION:** Be aware of the following points.

- When returning brake pedal (1), don't quickly release your foot from the pedal. By failure to do so, all hydraulic oil in the circuit is discharged, possibly causing the machine to start moving. Pay close attention when operating the brake.
- If brake pedal (1) is repeatedly stepped on more than necessary, the hydraulic oil will be temporarily discharged from the accumulator, causing the oil pressure to decrease and possibly resulting in insufficient brake capacity. Use an extra care.

An full-hydraulic brake system is employed on this machine so that powerful braking force is applied by lightly touching brake pedal (1). Accordingly, only use sudden brake operation in case of emergency.

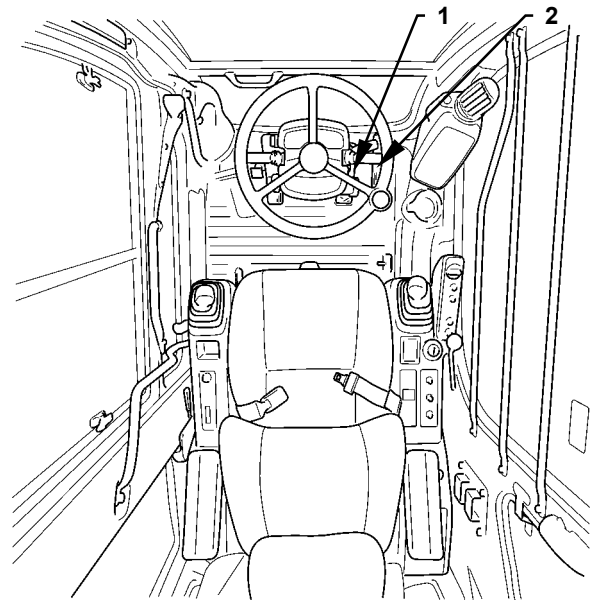

MCBB-01-002

1. Operate the brake pedal in the following procedures to smoothly stop the machine:
  - (1) Slowly release forward/reverse travel pedal (2) when the machine approaches 25 to 35 m before the target area to stop.
  - (2) Lightly depress brake pedal (1) when the machine approaches 5 to 6 m before the target area to stop.
  - (3) Slightly release brake pedal (1) just before the machine reaches the target area and re-depress the pedal to completely stop the machine.
2. In case the brake becomes inoperable, turn brake switch (3) to the P (parking brake) position. However, only use this operation in case of emergency. After using this operation, sufficiently check that the parking brake has no failure.

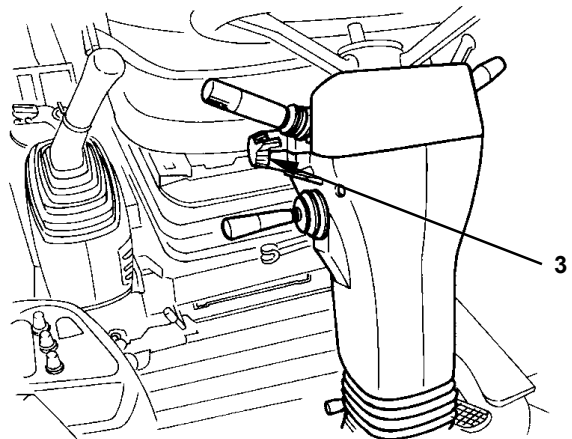

M216-01-021

## OPERATOR'S STATION

---

### ALTERNATOR INDICATOR

Red indicator will light with low alternator output. Check electrical system.

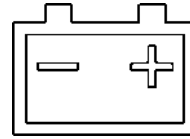

M178-01-038

### PREHEAT INDICATOR

Orange indicator will light when the key switch is turned to ON position in cold weather. Light will turn off after a few seconds, indicating that the preheat is completed.



M178-01-041

### HYDRAULIC OIL FILTER RESTRICTION INDICATOR (If equipped)

Red indicator will light when the hydraulic oil filter element is clogged. Clean or replace the filter element.



M1CC-01-039

# OPERATOR'S STATION

## SWITCH PANEL (Optional)

 **NOTE:** The optional switch locations differ depending on the kinds of optional devices are equipped. Before using the switches on the switch panel, make sure what kind of optional devices are equipped. All available optional devices are shown below.

- Travel Alarm Deactivation
- Swing Alarm Deactivation
- Seat Heat Switch
- Rear Light
- Rotating Lamp

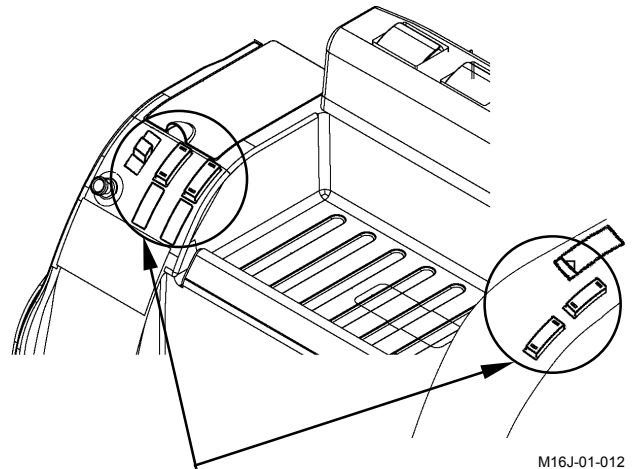

Optional Switch

M16J-01-012

### Travel Alarm Deactivation Switch (Optional)

The travel alarm buzzer sounds during travel operation. When push the travel alarm deactivation switch, the travel alarm buzzer function is deactivated.

### Swing Alarm Deactivation Switch (Optional)

The swing alarm system sounds the buzzer and turns the beacon light ON during swing operation. When push the swing alarm deactivation switch is set to the OFF position, the swing alarm buzzer function is deactivated.

### Seat Heat Switch

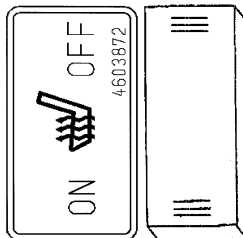

M1G6-01-019

### Rear Light

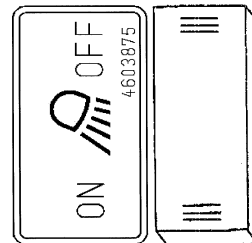

M1G6-01-020



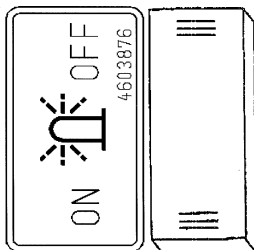

### Rotating Lamp



M1G6-01-021

## OPERATOR'S STATION

- **Temperature Control Switch (9)**  
Sets the air temperature in the range of 18 to 32.0 °C or 63 to 91°F in the MANUAL and AUTO modes. Temperature can be set by 0.5 °C or 1°F increments. The set-temperature is displayed on the LCD (8) center.
  - **Increasing Temperature**  
Each time the top side mark “^” on temperature control switch (9) is pressed, the set-temperature is increased by 0.5 °C or 1°F increments.
  - **Decreasing Temperature**  
Each time the bottom side mark “v” on temperature control switch (9) is pressed, the set-temperature is decreased by 0.5 °C or 1°F increments.
  - **Shifting Display of Temperature Scale (Celsius ↔ Fahrenheit)**  
Press and hold “^” and “v” on temperature control switch (9) for more than 5 seconds at the same time to shift the display of temperature scale (Celsius ↔ Fahrenheit) (temperature unit is not displayed).
  - **Mode Switch (10)**  
Selects the air vent in the four modes as shown below:

-  : Front/Defroster Vent Mode
-  : Front/Rear/Defroster Vent Mode
-  : Front/Rear/Foot/Defroster Vent Mode
-  : Foot Vent Mode

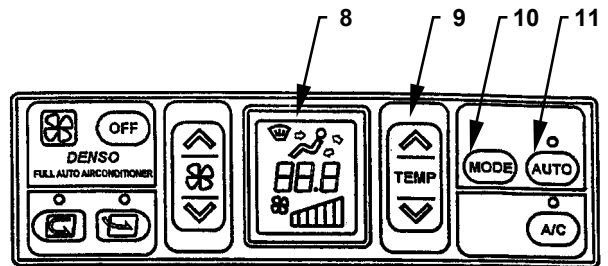

- **AUTO Switch (11)**  
Selects the air conditioner operation mode in either AUTO or MANUAL.
  - **AUTO Operation Mode**  
Press AUTO switch (11). When the indicator comes ON, the AUTO operation mode is selected. In response to the set-temperature, the blower speed, vent mode, and ventilation mode are automatically controlled.
  - **MANUAL Operation Mode**  
Press AUTO switch (11). When the indicator goes OFF, the MANUAL operation mode is selected. Air temperature, blower speed, vent mode, and ventilation mode can be selected as desired.



M178-01-017

# OPERATOR'S STATION

## DEFROSTER OPERATION

1. Press AUTO Switch (9). Temperature-controlled air blows out. During cold weather season when starting the engine, the engine coolant temperature and air temperature in the cab are low. Then, cool air is restricted not to flow in the cab to the minimum (LO) by the Heater Start-Operation Control System.
2. Set temperature control switch (11) so that 「25.0」 is indicated on LCD (7). Set fresh air vent switch (13) in the fresh air circulation mode.
3. Select the front vents  or the front and rear vents  using MODE switch (14).

Control air flow direction by adjusting the louvers at the front vent (1) and the defroster vent (3).

Control air temperature in the cab by operating temperature control switch (11). If the windowpanes become clouded in rainy season or when dehumidifying, turn the indicator of A/C switch (8) ON.

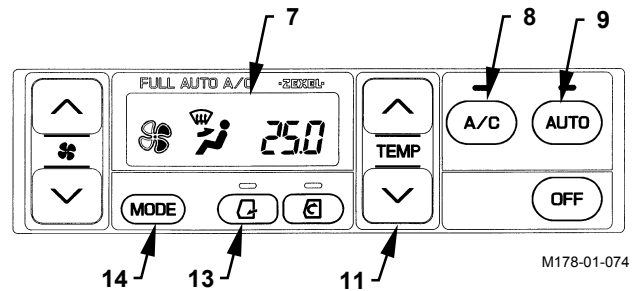

M178-01-074

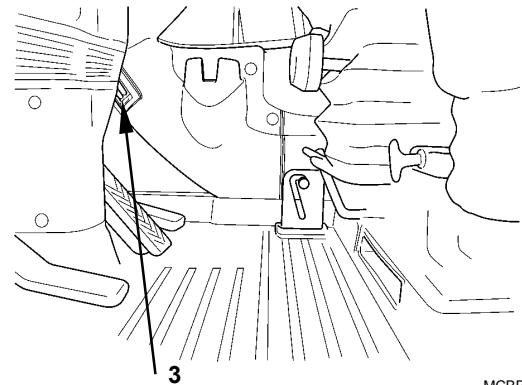

MCBB-01-003

### Cool Head / Warm Feet Operation

Cool and warm air is simultaneously supplied to the head vents and feet vents respectively.

1. Press blower switch (6) to adjust the blower speed.
2. Press MODE switch (14) to display the front and rear vent  mark on the liquid crystal panel. Then, turn A/C switch (8) ON (indicator lights).

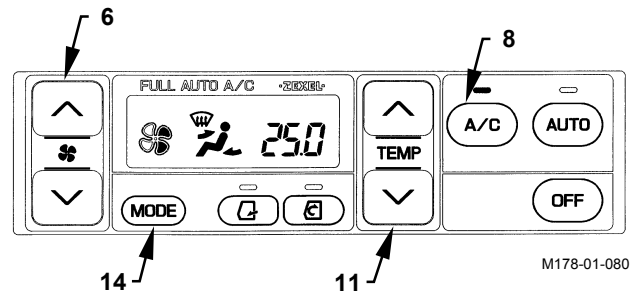

M178-01-080

Control air temperature inside the cab by operating temperature control switch (11).

## OPERATOR'S STATION

### OPENING/CLOSING OVERHEAD WINDOW

(Std. Model)

#### Opening

1. Move lock levers (1) toward center of window.
2. Hold handle (2) and lift window until it rises upright. With the window positioned upright, it will be secured in position by dampers (3).

#### Closing

1. Hold handle (2) and pull window down until "click" sound is heard from locks (1).

Note that the overhead window can be used as an emergency exit.

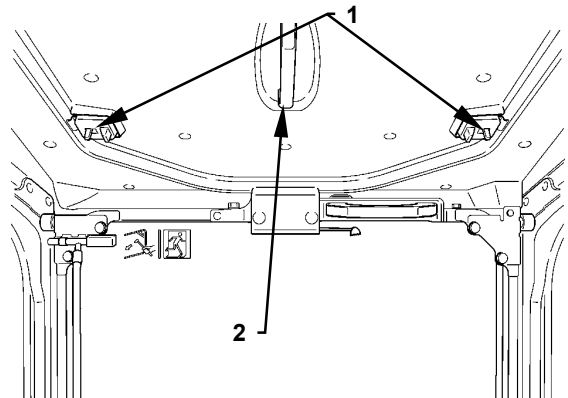

M178-01-059

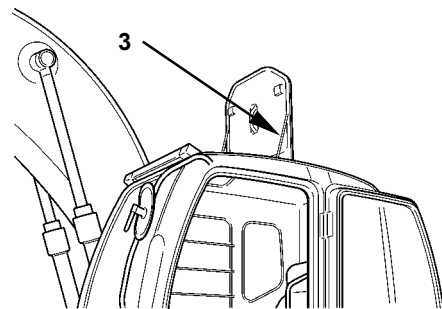

M178-01-062

### OPENING/CLOSING OVERHEAD WINDOW

(Clear Hatch: If Equipped)

#### Opening

1. Move lock levers (1) toward center of window.
2. Hold handle (2) and lift window until it rises upright. With the window positioned upright, it will be secured in position by dampers (3).

#### Closing

1. Hold handle (2) and pull window down until "click" sound is heard from locks (1).

Note that the overhead window can be used as an emergency exit.

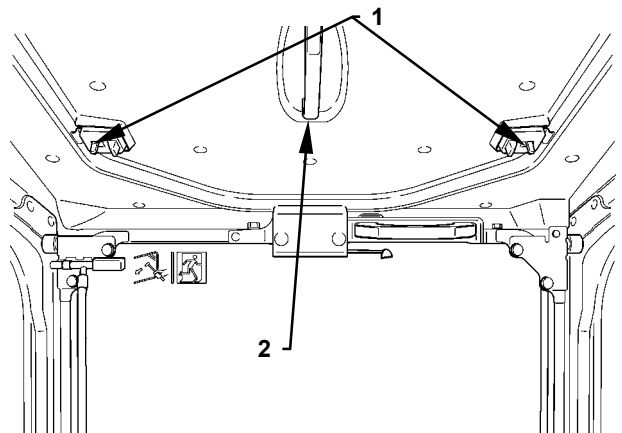

M178-01-059

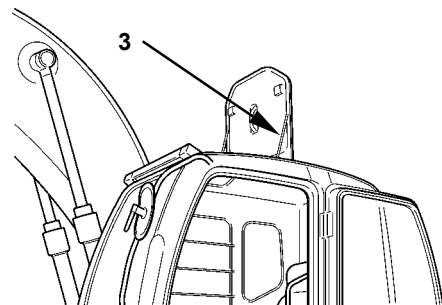

M178-01-062

#### IMPORTANT:

- Replace the clear hatch with a new one every 5 years even if undamaged. In case it was remarkably damaged or has received severe shock loads, replace it even if it has been not in use for 5 years.
- When cleaning the clear hatch, use a neutral detergent. If acidic or alkaline detergent is used, the clear hatch may become discolored or crack.
- Keep organic solvent away from the clear hatch. Failure to do so may cause the clear hatch to become discolored or crack.

# OPERATING THE ENGINE

---

## **INSPECT MACHINE DAILY BEFORE STARTING**

### **ELECTRICAL SYSTEM**

Check for worn or frayed wires and loose connections.

### **BOOM, BUCKET, SHEET METAL, CHASSIS**

Check for bent, broken or missing parts.

### **HARDWARE**

Check for loose or missing parts.

### **FUEL SYSTEM**

Drain water and deposits from fuel tank.

### **HYDRAULIC SYSTEM**

Check for leaks, kinked hoses, and lines or hoses that rub against each other or other parts.

### **LUBRICATION**

Check lubrication points on the Periodic Service Chart.

### **PROTECTIVE DEVICES**

Check guards, fenders.

### **SAFETY**

Walk around machine to clear all bystanders/obstacles from machine area.

## DRIVING THE MACHINE

---

### Precautions

1. Check the tires for any damage, such as scratches, cracks, etc..  
Check the pressure of each tire.  
Check for obstructions or danger around the machine.
2. Raise stabilizers/blade.
3. Position the front attachment to the front of the machine, then insert the swing lock lever.
4. When traveling on a public road, position the front attachment as illustrated below, then place the pilot control shutt-off lever in the "LOCK" position.

### Starting

5. Be sure that brake oil pressure gauge needle remains within the white range.
6. Check for safety around the machine. Place the shift lever to the drive or low position. Turn the brake switch OFF to release the parking brake. Only the 210W's engine speed (travel idle speed) will increase approx.  $200 \text{ min}^{-1}$  (rpm) faster than the starting speed at this time. Slowly step on the forward/reverse pedal to start traveling. Use the accelerator pedal to accelerate or decelerate the travel speed.
7. In a safe place, confirm that the brakes function properly.

## OPERATING THE MACHINE

### STEERING WHEEL COLUMN

The tilt angle of the steering wheel column on this machine can be adjusted. When tilting steering wheel column (1) backward, pull steering wheel column (1) while pushing down tilt lever (2). Release tilt lever (2) to lock steering wheel column (1) in that position. When standing steering wheel column (1) upright, push down tilt lever (2). The steering wheel column is automatically tilted back to the upright direction. When tilt lever (2) is released on a half way, the steering wheel column is automatically locked in that position.

**IMPORTANT:** If the front window is opened or closed with the steering wheel column upright, the steering wheel comes in contact with the front window. Before opening or closing the front window, be sure to tilt the steering wheel column backward.

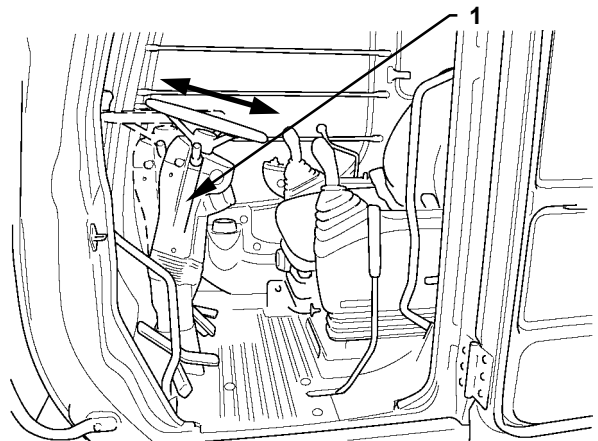

MCBB-05-004

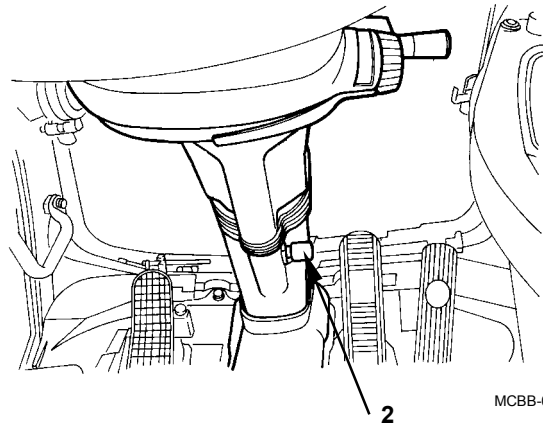

MCBB-05-003

## OPERATING THE MACHINE

---

### PRECAUTIONS FOR OPERATIONS



**CAUTION:** Investigate the work site before starting operations.

- Be sure to install an overhead cab guard when operating in a work site which has a possibility of falling objects.
- If operation on soft ground is required, sufficiently reinforce the ground beforehand.
- Be sure to wear close fitting clothing and safety equipment appropriate for the job, such as a hard hat, etc. when operating the machine.
- Clear all persons and obstacles from area of operation and machine movement.  
Always beware of the surroundings while operating. When working in a small area surrounded by obstacles, take care not to hit the upperstructure against obstacles.
- When loading onto trucks, bring the bucket over the truck beds from the rear side. Take care not to swing the bucket over the cab or over any person.

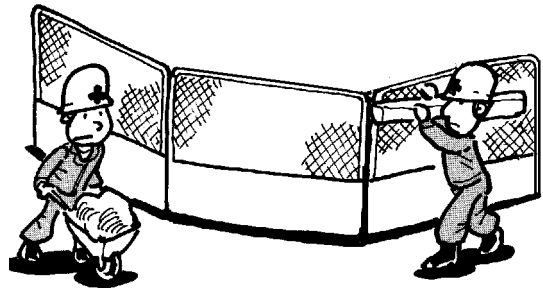
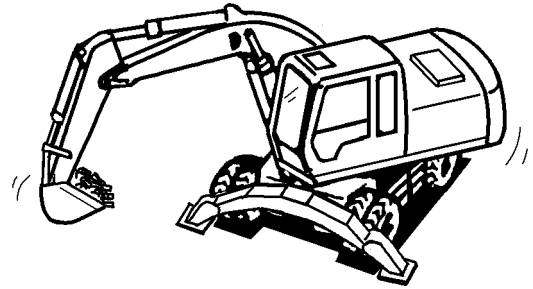

M202-05-014

## OPERATING THE MACHINE

---

### OVERNIGHT STORAGE INSTRUCTIONS

1. After finishing the day's operation, drive the machine to a firm, level ground where no possibility of falling stones, ground collapse, or floods. Park the machine referring to the "PARKING THE MACHINE" in the "DRIVING THE MACHINE" section.
2. Fill the fuel tank with fuel.
3. Clean the machine.
4. If anti-freeze or long life coolant is not used in cold weather, be sure to drain coolant from the radiator and the engine jacket. Also, be sure to put a tag in a visible place if the coolant has been drained.

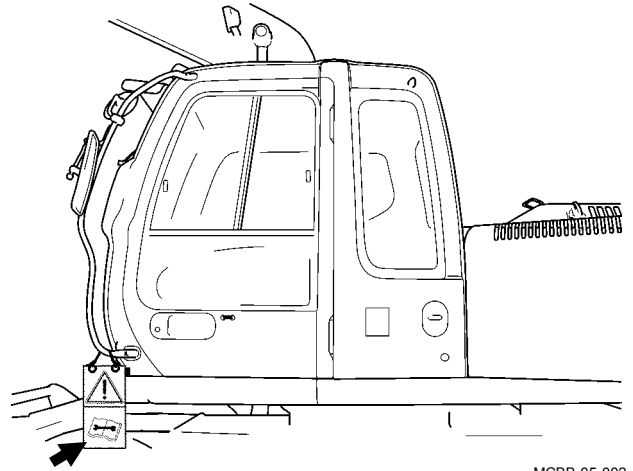

CLICK HERE TO **DOWNLOAD** THE COMPLETE MANUAL

- Thank you very much for reading the preview of the manual.
- You can download the complete manual from: [www.heydownloads.com](http://www.heydownloads.com) by clicking the link below



- Please note: If there is no response to CLICKING the link, please download this PDF first and then click on it.

CLICK HERE TO **DOWNLOAD** THE COMPLETE MANUAL

# MAINTENANCE

## LAYOUT

### Monoblock boom

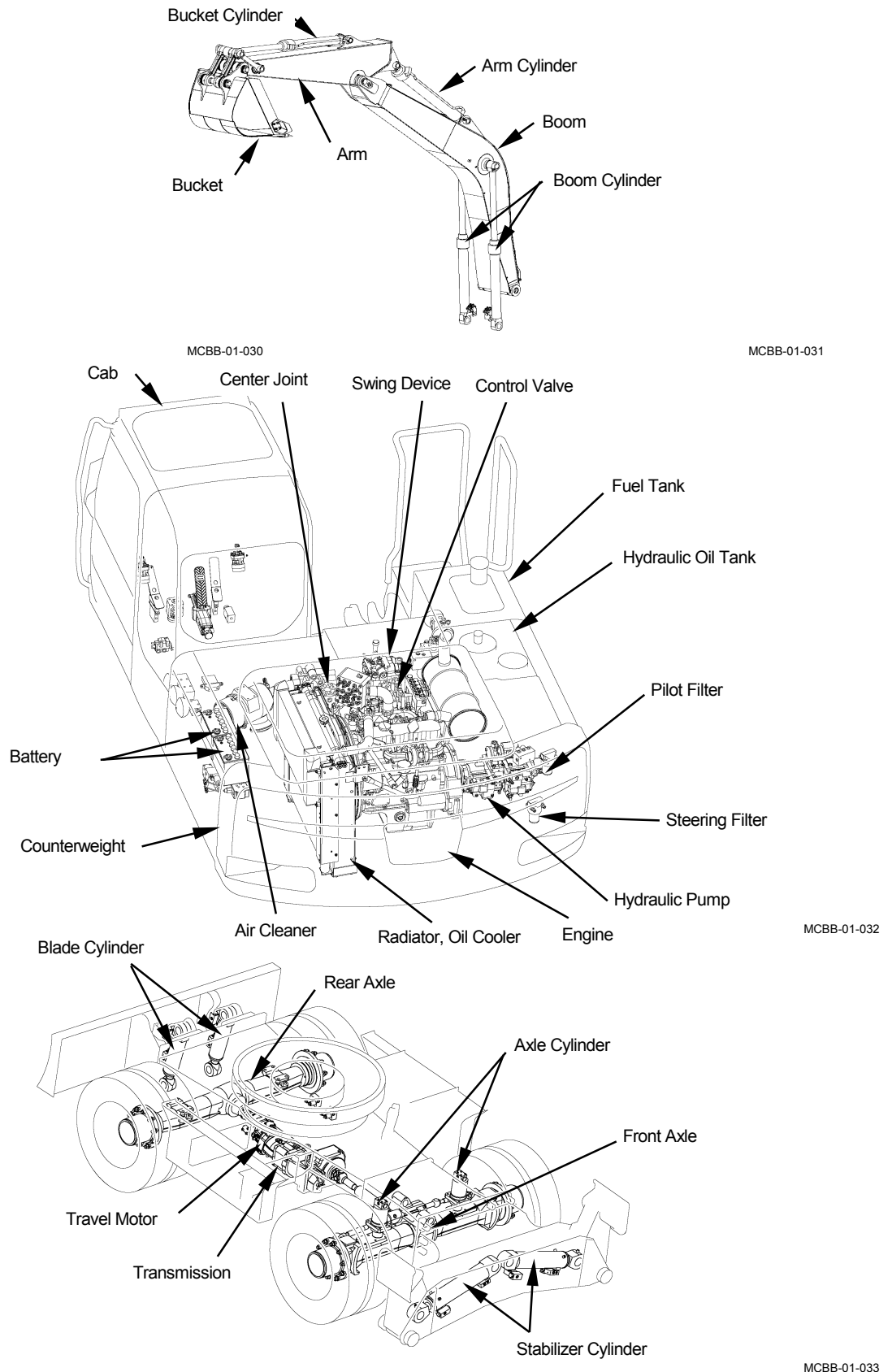

## MAINTENANCE

### Brand Names of Recommended Grease

Where to be applied	Bucket, Arm and Boom, Swing Gear, Swing Bearing, Front Axle, Propel Shaft, Equalizer Pin	
Manufacturer	-20 to 40 °C (-4 to 104 °F)	
Nippon Koyu	SEP 2	*2
British Petroleum	BP Energrease	LS-EP2
Caltex Oil	Multifax	EP2
Esso	Beacon	EP2
Idemitsu Kosan	Daphne Coronex Grease	EP2
Mobil Oil	Mobilux	EP2
Nippon Oil	Epinoc Grease	AP2
Shell Oil	Shell Alvania	EP2 *1

 **NOTE:** The machine shipped from the factory is filled with lubricants marked with     .

- \*1 Front Joint Pin and Swing Bearing
- \*2 Swing Gear

### Recommended Engine Oil

Depending upon the expected air temperature range between oil changes, use the oil viscosity shown on the temperature chart below.

### API CD Class

SAE 30 or equivalent (both summer and winter)  
 High temperature areas, SAE 40 or equivalent  
 Low temperature areas, SAE 10W or equivalent

### Brand Names of Recommended Engine Oil

Kind of Oil	Engine Oil		
Application	Engine Crank Case Fuel Injection Pump and Governor		
Air			
Temp.	-20 to 0 °C (-4 to 32 °F)	-10 to 35 °C (14 to 95 °F)	25 to 40 °C (77 to 104 °F)
Manufacturer			
British Petroleum	BP Vanellus C3		
	10W	30	40
Caltex Oil	RPM DELO 300 Oil		
	10W	30	40
Esso	Essolube D-3		
	10W	30	40
Idemitsu Kosan	Apolloil diesel motive		
	S-310	S-330	S-340
	-15 to 40 °C (5 to 104 °F) Apolloil custom wide 15W-40		
	Apolloil super wide 15W-40		
Mobil Oil	Mobil Delvac		
	1310	1330	1340
	Hidiesel S 3		
Nippon Oil	-20 to 35 °C (-4 to 95 °F) 10W-30	-10 to 40 °C (14 to 104 °F) 15W-40	
	Rymla D		
Shell Oil	Rymla D		
	10W	30	40

 **NOTE:** The machine shipped from the factory is filled with lubricants marked with     .

# MAINTENANCE

## B. ENGINE

### 1 Engine Oil Level --- check daily

**IMPORTANT:** For most accurate readings, check the oil level every day before starting the machine. Be sure the machine is on a level surface.

1. Remove dipstick (1). Wipe oil off with a clean cloth. Reinsert dipstick (1).
2. Remove dipstick (1) again. Read level. Oil level must be between the circle marks.
3. If necessary, add oil via oil filler cap (2). Be sure to use only recommended oil (see Recommended Engine Oil Chart).

 **NOTE:** Checking the oil level immediately after shut down will result in inaccurate readings. Be sure to allow the oil to settle for at least 10 minutes before checking.

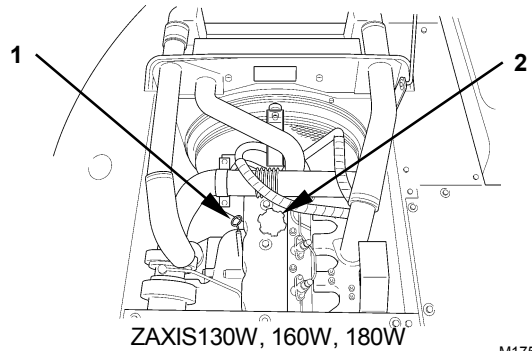

M175-07-032

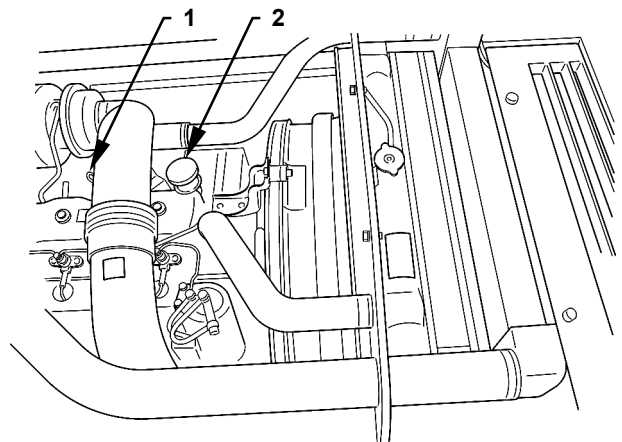

M178-07-029

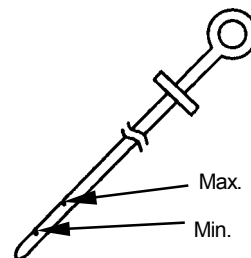

M178-07-011

## MAINTENANCE

### 1

#### Check Brake Accumulator

1. Start the engine with the brake switch in the column box turned to the P (parking brake) position.
2. After performing warm up operation, move the brake pedal four to five strokes. Then, stop the engine.
3. Turn the key switch ON.
4. Fully step on the brake pedal from 8 to 9 strokes. The buzzer will sound and brake pressure indicator (1) will light when normal. If the buzzer sounds and the brake pressure indicator lights before the brake pedal is stepped on three strokes, the pressure charged in the accumulator is abnormal. Don't travel the machine. Ask your nearest Hitachi dealer to replace the brake accumulator.
5. Repeat the above procedures three times to obtain the correct result and check that no abnormality is present.

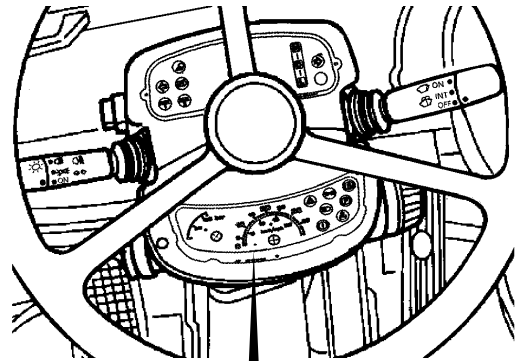

MCBB-01-009

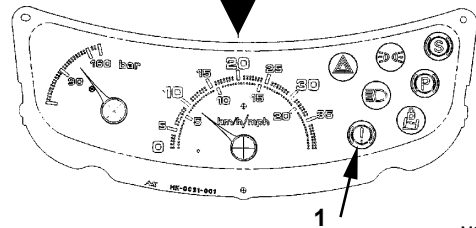

MCBB-01-006

## MAINTENANCE

### Bleed Air from Hydraulic System

After changing hydraulic oil, bleed any remaining air from the hydraulic system in the following procedures:

**CAUTION:** • If air is remaining in the brake system, the brake performance will be reduced, possibly creating hazardous conditions. Be sure to bleed air from the brake system.

- Air trapped in the travel transmission gearshift hydraulic circuit will cause erratic operation in the gearshift function, increasing hazardous condition. Be sure to bleed air from the travel transmission gearshift circuit.

**IMPORTANT:** If the engine is started without filling the hydraulic pump with oil, damage to the hydraulic pump may result. Be sure to bleed air and fill the hydraulic pump with oil before starting the engine.

- Bleed air remaining in the hydraulic pump.
  - 1) Remove air vent plug (4) from the top of the pump. Fill the pump with oil.
  - 2) After filling the pump with oil, temporarily tighten air vent plug (4). Start the engine and run at slow idle.
  - 3) Slightly loosen air vent plug (4) to bleed any air remaining in the pump until hydraulic oil oozes from the gap around the plug.
  - 4) Completely tighten air vent plug (4) after bleeding air.
- Bleed air remaining in the hydraulic circuits.
  - 1) After filling hydraulic oil, start the engine. Operate each cylinder and swing motor evenly without applying any loads for approx. 10 to 15 minutes. The pilot circuit has an air breather so that air can be automatically purged within 5 minutes during above operation.
  - 2) Position the front attachment in the oil-level-check position.
  - 3) Stop the engine. Check the oil level. Refill oil as necessary.
- Bleed Air from Brake System  
Be sure to bleed air from the brake system in accordance with the description on page

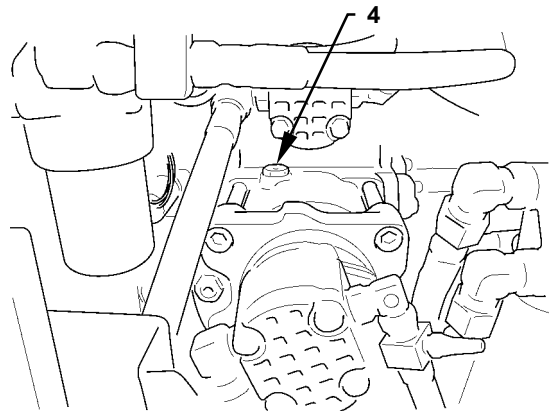

ZAXIS130W, 160W

MCBB-07-055

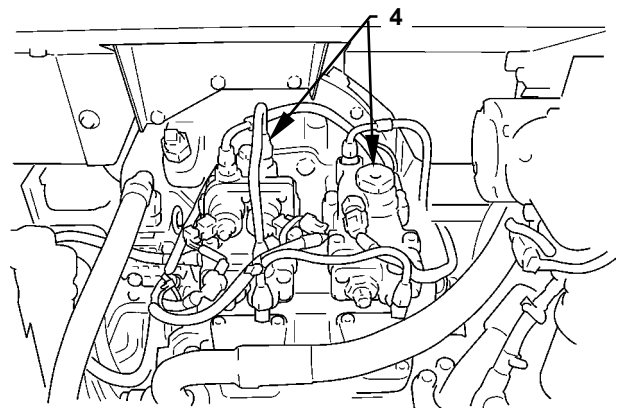

ZAXIS180W, 210W

M178-07-021

# MAINTENANCE

Table 2. Lines

Interval(hours)	Check Points	Abnormalities	Remedies
Daily	Contact surfaces of flange joints	Leak (11)	Replace O-ring and/or retighten bolts
	Welded surfaces on joints	Leak (12)	Replace
Every 250 hours	Joint neck	Crack (13)	Replace
	Welded surfaces on joints	Crack (12)	Replace
	Clamps	Missing Deformation Loose	Replace Replace Retighten

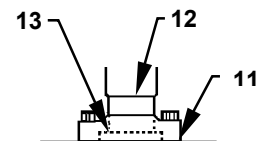

M137-07-001

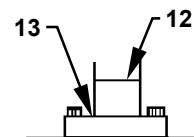

M137-07-007

Fig.2

**NOTE:** Refer to the illustrations in Fig.2 for each check point location or for a description of the abnormality. Use genuine Hitachi parts.

Table 3. Oil cooler

Interval(hours)	Check Points	Abnormalities	Remedies
Every 250 hours	Contact surfaces of flange joints	Leak (14)	Replace O-ring and/or retighten bolts
	Oil cooler Coupling and rubber hose	Leak (15) Leak (16)	Replace Retighten or replace

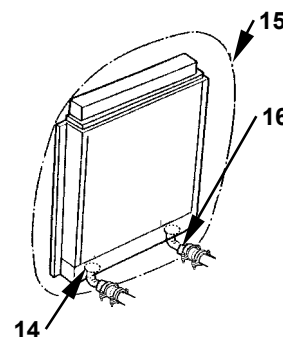

M137-07-002

Fig.3

**NOTE:** Refer to the illustrations in Fig.3 for each check point location .

# MAINTENANCE

## H. AIR CLEANER

- 1** **Clean Air Cleaner Outer Element**  
--- every 250 hours or when the restriction indicator comes ON
- Replace Air Cleaner Element**  
--- after cleaning element 6 times or after one year

1. Stop the engine before servicing outer element (1).
2. Remove cover clamps (2) (4 places) to remove outer element (1). (Do not remove inner element at this time.)

**CAUTION:** When using compressed air [0.2 MPa (2 kgf/cm<sup>2</sup>) or less], always wear safety goggles.

**IMPORTANT:** Do not tap or hit outer element (1) to other objects to clean it.

3. Clean outer element (1) by blowing compressed air [0.2 MPa (2 kgf/cm<sup>2</sup>) or less] from the inside. Check that outer element (1) is free from damage after cleaning. Replace with a new one if any damage is found.
4. Even if outer element (1) has not been cleaned 6 times yet, in case the air filter restriction indicator comes ON soon after cleaning, replace the element with a new one. Install the cover with the TOP mark in the correct position.

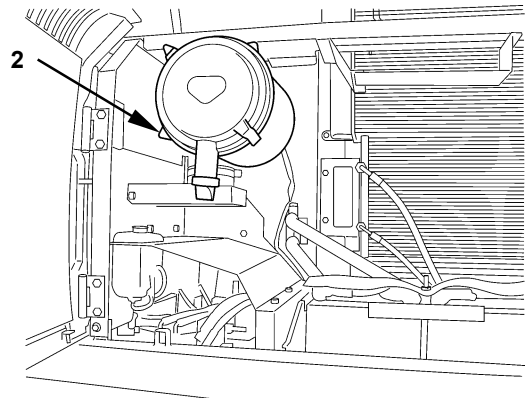

ZAXIS130W, 160W, 180W

MCBB-07-071

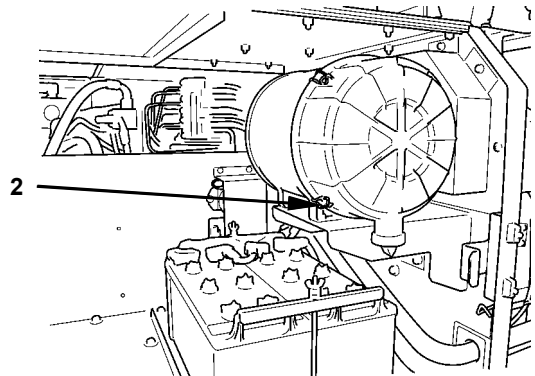

ZAXIS210W

MCBB-07-030

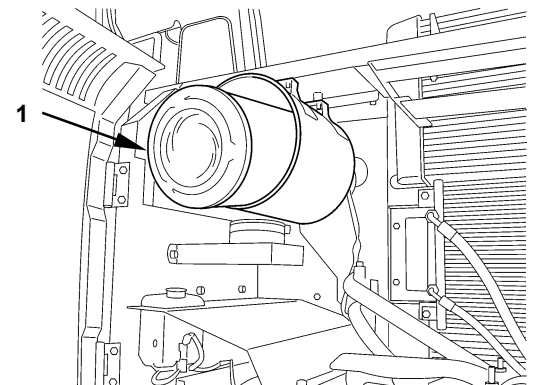

ZAXIS130W, 160W, 180W

MCBB-07-072

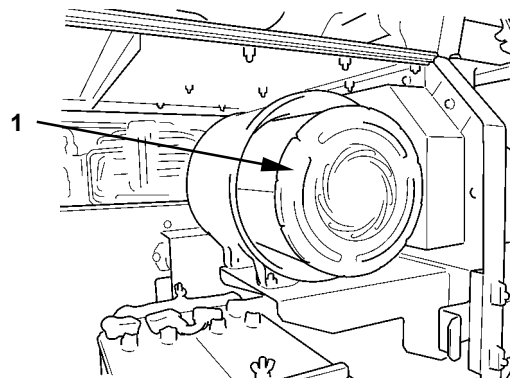

ZAXIS210W

MCBB-07-031

# MAINTENANCE

## REPLACING FUSES

If any electrical equipment fails to operate, first check the fuses. Fuse box is located behind the operator's seat. A fuse location/specification decal is attached to the fuse box cover.

Remove the fuse box cover by lifting it upward. Spare fuses are located on the underside of the cover.

**IMPORTANT: Be sure to install fuses with correct amperage ratings to prevent electrical system damage due to overload.**

- |                     |                       |
|---------------------|-----------------------|
| 10- OPTION 3<br>5A  | 20- POWER UNIT<br>10A |
| 9- OPTION 2<br>10A  | 19- GLOW. R<br>5A     |
| 8- OPTION 1<br>5A   | 18- AUXILIARY<br>10A  |
| 7- AIRCON<br>5A     | 17- ROOM LAMP<br>5A   |
| 6- POW. ON<br>5A    | 16- LIGHTER<br>10A    |
| 5- SWBOX<br>5A      | 15- RADIO<br>5A       |
| 4- SOLENOID<br>10A  | 14- HORN<br>10A       |
| 3- EC. MOTOR<br>10A | 13- HEATER<br>20A     |
| 2- CONTROLLER<br>5A | 12- WIPER<br>10A      |
| 1- BACKUP<br>5A     | 11- LAMP<br>20A       |

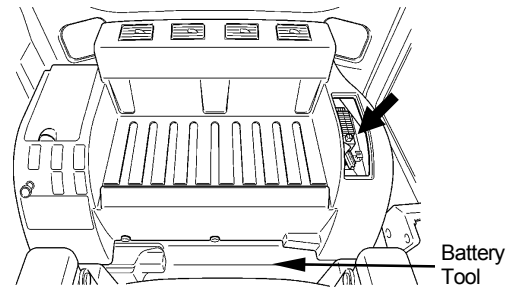

M178-07-036

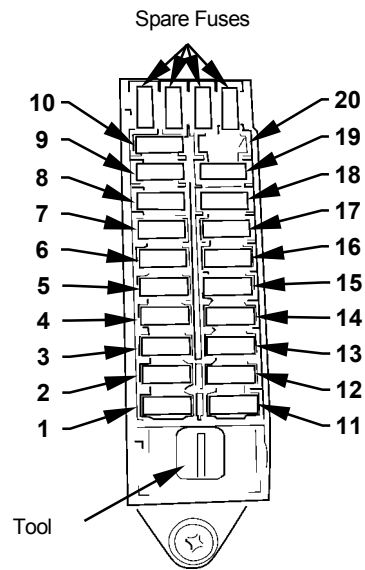

M178-07-034

## MAINTENANCE

### 8 Check the Air Conditioner --- daily

1. Check pipe connections for refrigerant gas leakage.  
If oil seepage is found around pipe connections, as illustrated, it indicates possible gas leakage.
2. Check refrigerant quantity.  
After running the engine at  $1500 \text{ min}^{-1}$  (rpm) for 2 to 3 minutes, check refrigerant quantity through the sight glass (2) on the receiver tank (1).
3. Check the condenser.  
If the condenser fins become clogged with dirt or insects, the cooling effect will be decreased. Be sure to keep it clean at all times. (Refer to "Clean Radiator Core" in Maintenance Section.)
4. Check the compressor  
After operating the air conditioner for 5 to 10 minutes, touch the high-pressure side and low-pressure side pipes with your hand. If normal, the high-pressure side pipe will be hot, and the low-pressure side cold.
5. Check mounting bolts for looseness.  
Confirm that the compressor mounting bolts and other mounting/fastening bolts are securely tightened.
6. Inspect belt, check and adjust tension.  
Visually check the compressor and fan belts for wear. Check and adjust belt tension, referring to the illustration (right).

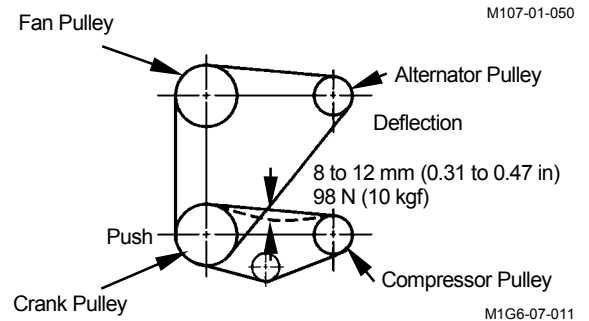
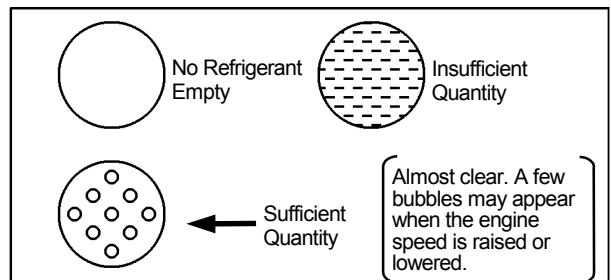
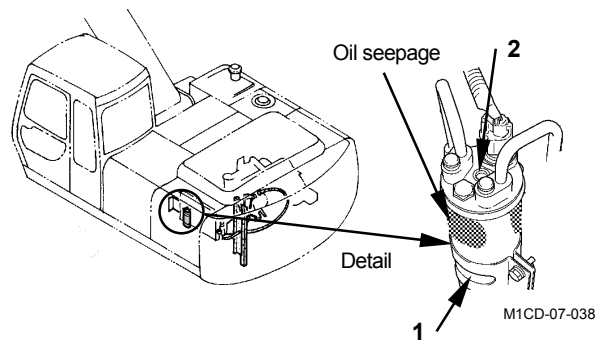

If any abnormalities are found in air conditioner operation, see your authorized dealer for inspection.

# MAINTENANCE

10. Retighten the swing motor mounting bolts.

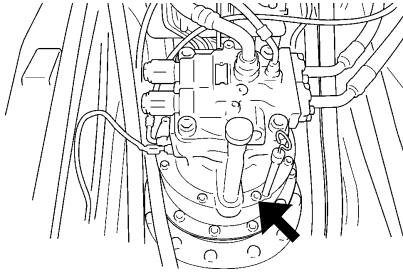

M178-07-086

11. Retighten the battery mounting nuts.

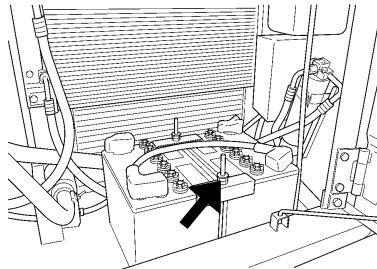

ZAXIS130W, 180W M175-07-015

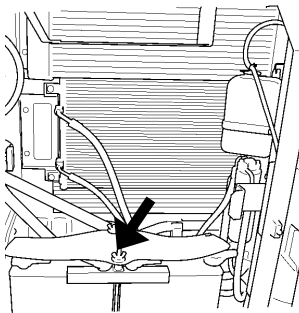

ZAXIS160W MCBB-07-056

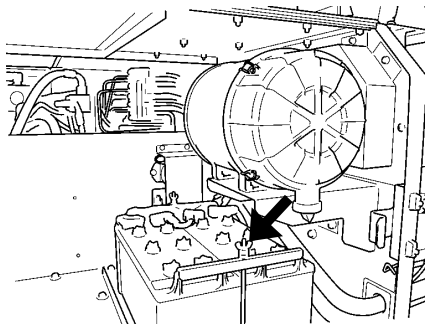

ZAXIS210W MCBB-07-030

12. Retighten the cab mounting nuts.

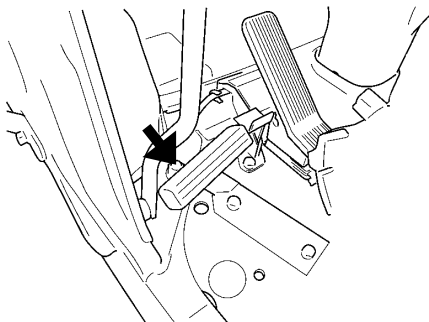

MCBB-07-037

# TROUBLESHOOTING

## TROUBLESHOOTING

If any machine trouble has occurred, immediately repair it. Make certain the cause of the trouble and take necessary measures to prevent the reoccurrence of the same trouble. In case troubleshooting is difficult, or measures marked with \* must be taken, consult the nearest Hitachi dealer. Never attempt to adjust, disassemble, or repair the hydraulic and/or electrical/electronic parts/components.

### 1. Engine

Consult the nearest Hitachi dealer for the engine troubleshooting.

### 2. Engine Auxiliaries

Problem	Cause	Solution
<b>Batteries will not be charged.</b>	Broken battery separator	Replace
	Faulty regulator	* Adjust and replace
	Faulty ground line	* Repair
	Faulty alternator	* Repair and replace
<b>Batteries discharges quickly after being charged.</b>	Shorted cable	* Repair and replace
	Shorted battery separator	* Repair and replace
	Increased sediment in battery	* Clean
<b>Coolant temperature is too high.</b>	Low coolant level	Add
	Loose engine fan V-belt	Adjust
	Damaged rubber hose	*Replace
	Faulty thermostat	*Replace
	Faulty coolant temperature gauge	*Replace

# SPECIFICATIONS

## Specifications

### ZAXIS130W (FRONT BLADE REAR STABILIZER)

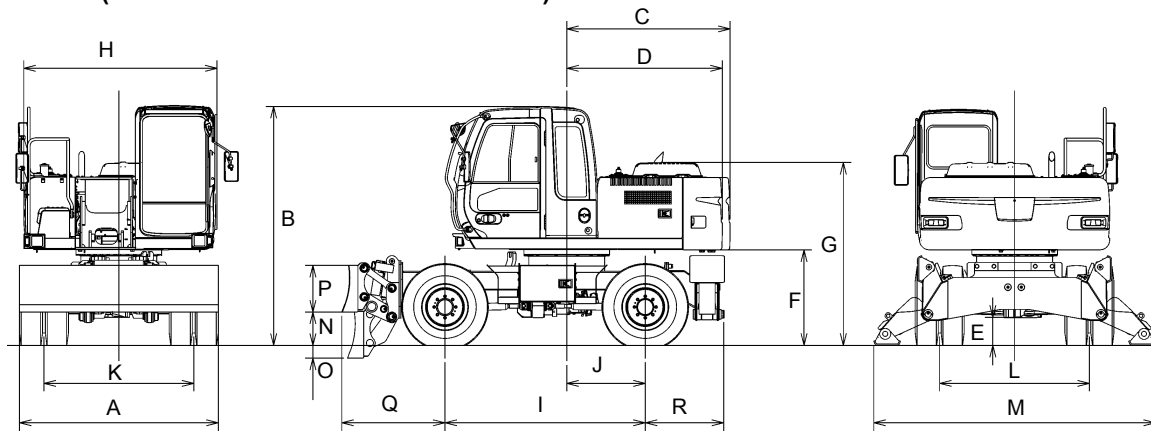

MCBB-12-017

Model		ZAXIS130W			
Type of Front-End Attachment		—			
Bucket Capacity (Heaped)		2.52m (8 ft 3 in)			
		PCSA 0.50m <sup>3</sup> (0.65yd <sup>3</sup> ), CECE 0.45m <sup>3</sup>			
Operating Weight		m <sup>3</sup> (yd <sup>3</sup> )			
Basic Machine Weight		kg (lb)			
Engine		ISUZU Engine family 4BG1XABF Engine Type 4BG1XABFA			
		Traveling		Digging	
				H/P mode	P mode
Engine Power	DIN 6271 net	kW/min <sup>-1</sup> (PS/rpm)	87.5 (119)/2200	86.2 (117)/1950	83 (113)/1750
	SAE J1349 net	kW/min <sup>-1</sup> (PS/rpm)	87.5 (119)/2200	86.2 (117)/1950	83 (113)/1750
	ISO 9249 net	kW/min <sup>-1</sup> (PS/rpm)	87.5 (119)/2200	86.2 (117)/1950	83 (113)/1750
	ECE-R24	kW/min <sup>-1</sup> (PS/rpm)	87.5 (119)/2200		
A: Overall Width (Excluding Rearview Mirrors)		mm (ft-in)	2530 (8' 4")		
B: Cab Height		mm (ft-in)	3030 (9' 11")		
C: Rear End Swing Radius		mm (ft-in)	1980 (6' 6")		
D: Rear End Length		mm (ft-in)	1980 (6' 6")		
E: Minimum Ground Clearance		mm (ft-in)	360 (1' 2")		
F: Counterweight Clearance		mm (ft-in)	1215 (4' 0")		
G: Engine Cover Height		mm (ft-in)	2320 (7' 7")		
H: Overall Width of Upperstructure		mm (ft-in)	2465 (8' 1")		
I: Wheelbase		mm (ft-in)	2550 (8' 4")		
J: Swing-center to Rear Axle		mm (ft-in)	1000 (3' 3")		
K: Front Wheel Tread		mm (ft-in)	1915 (6' 3")		
L: Rear Wheel Tread		mm (ft-in)	1915 (6' 3")		
M: Stabilizer Spread		mm (ft-in)	3570 (11' 9")		
N: Max. Raising Height		mm (ft-in)	440 (1' 5")		
O: Max. Digging Depth		mm (ft-in)	150 (6")		
P: Blade Height		mm (ft-in)	590 (1' 11")		
Q: Front Axle to Front of Chassis		mm (ft-in)	1310 (4' 4")		
R: Rear Axle to Rear of Chassis		mm (ft-in)	1010 (3' 4")		
Tire Size		—	10.00-20 14PR		
Swing Speed		min <sup>-1</sup> (rpm)	13.1		
Travel Speed (fast/low/creeper) ※		km/h(mph)	34/8.6/2.5 (21.1/5.3/1.6)		
Gradeability		degree(%)	35 (70)		

NOTE: ※ The specification not matching the local regulation is excluded.

# SPECIFICATIONS

## WORKING RANGES

### ZAXIS160W

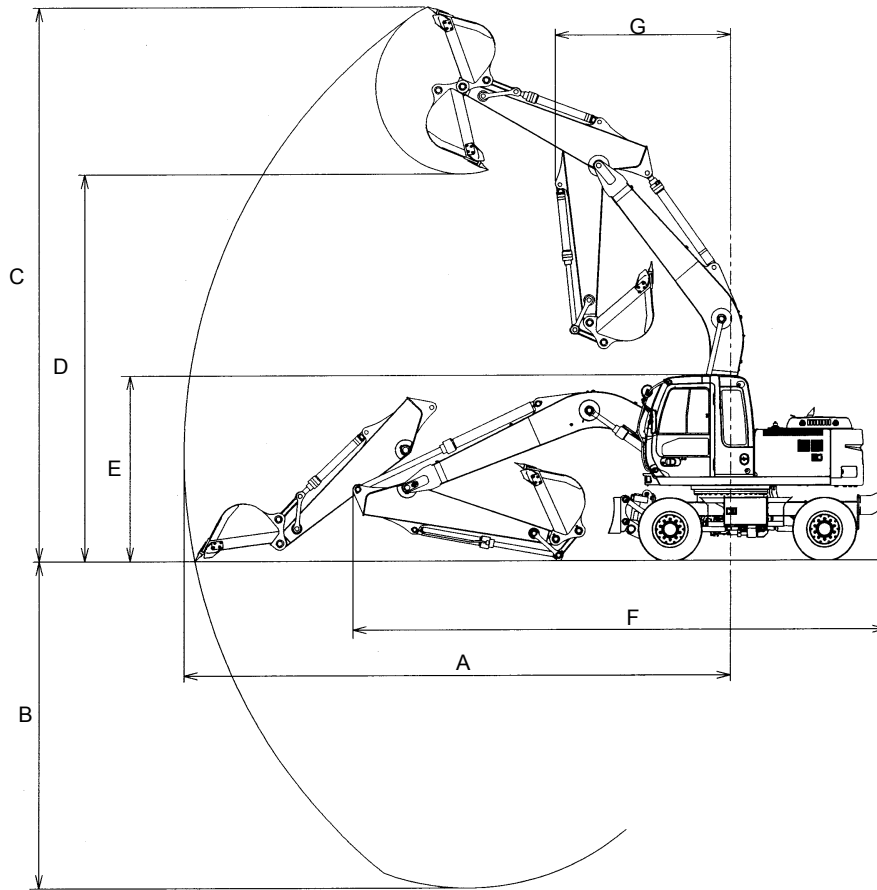

MCBB-12-006

Model Category		ZAXIS160W		
		2.01 m (6 ft 7 in) Arm	2.58 m (8 ft 6 in) Arm	3.10 m (10 ft 2 in) Arm
Item		Backhoe	Backhoe	Backhoe
A: Maximum Digging Reach	mm (ft·in)	8470 (27' 9")	9000 (29' 6")	9460 (31' 0")
B: Maximum Digging Depth	mm (ft·in)	4770 (15' 8")	5340 (18' 0")	5840 (19' 2")
C: Maximum Cutting Height	mm (ft·in)	8730 (28' 8")	9090 (29' 10")	9340 (30' 8")
D: Maximum Dumping Height	mm (ft·in)	6040 (19' 10")	6350 (20' 10")	6600 (21' 8")
E: Transport Height	mm (ft·in)	3130 (10' 3")	3045 (10' 0")	3120 (10' 3")
F: Overall Transport Length				
Std. Shassis Rear BL	mm (ft·in)	8510 (27' 11")	* 8790 (28' 10")	* 8820 (28' 11")
Short Shassis Rear BL	mm (ft·in)	8510 (27' 11")	8410 (27' 7")	8440 (27' 8")
Std. Shassis Rear STB.	mm (ft·in)	8510 (27' 11")	* 8790 (28' 10")	* 8820 (28' 11")
Short Shassis Rear STB.	mm (ft·in)	8510 (27' 11")	8410 (27' 7")	8440 (27' 8")
Front BL Rear STB.	mm (ft·in)	8510 (27' 11")	* 9090 (29' 10")	* 9120 (29' 11")
Front STB. Rear BL	mm (ft·in)	8510 (27' 11")	* 9090 (29' 10")	* 9120 (29' 11")
Front STB. Rear STB.	mm (ft·in)	8510 (27' 11")	* 9090 (29' 10")	* 9120 (29' 11")
G: Minimum Swing Radius	mm (ft·in)	3280 (10' 9")	2900 (9' 6")	2920 (9' 7")

NOTE: \* Transport the machine with the rear side facing forward.

# SPECIFICATIONS

## Specifications

### ZAXIS210W (REAR STABILIZER)

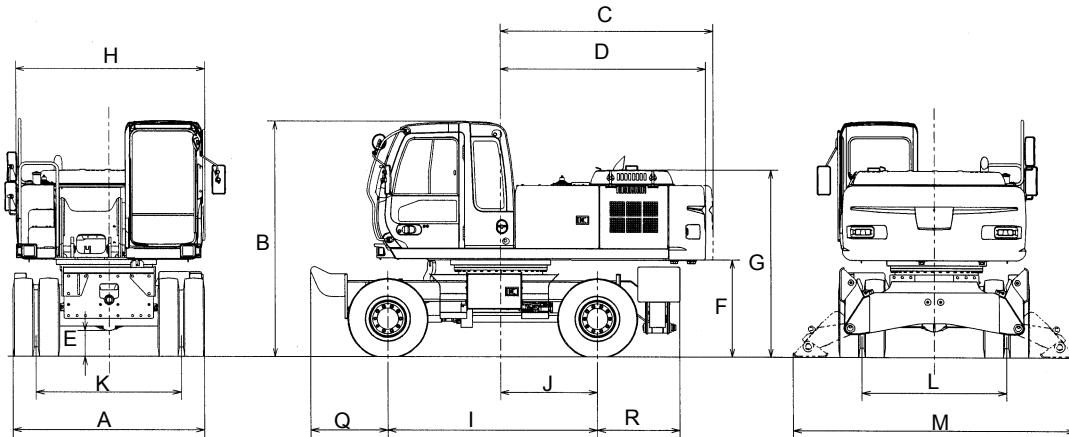

MCBB-12-009

Model		ZAXIS210W			
Type of Front-End Attachment		—			
Bucket Capacity (Heaped)		2.91m (9 ft 7 in)			
Operating Weight		PCSA 0.80m <sup>3</sup> (1.05yd <sup>3</sup> ), CECE 0.70m <sup>3</sup>			
Basic Machine Weight		kg (lb)			
Engine		ISUZU Engine family 6BG1XAB Engine Type 6BG1XABFA			
		Traveling		Digging	
				H/P mode	P mode
Engine Power	DIN 6271 net	kW/min <sup>-1</sup> (PS/rpm)	110 (150)/2100	110 (150)/2100	105.6 (144)/1900
	SAE J1349 net	kW/min <sup>-1</sup> (PS/rpm)	110 (150)/2100	110 (150)/2100	105.6 (144)/1900
	ISO 9249 net	kW/min <sup>-1</sup> (PS/rpm)	110 (150)/2100	110 (150)/2100	105.6 (144)/1900
	ECE-R24	kW/min <sup>-1</sup> (PS/rpm)	108.1 (147)/2100		
A: Overall Width (Excluding Rearview Mirrors)		mm (ft-in)	2500 (8' 2")		
B: Cab Height		mm (ft-in)	3110 (10' 2")		
C: Rear End Swing Radius		mm (ft-in)	2700 (8' 10")		
D: Rear End Length		mm (ft-in)	2690 (8' 10")		
E: Minimum Ground Clearance		mm (ft-in)	340 (1' 1")		
F: Counterweight Clearance		mm (ft-in)	1275 (4' 2")		
G: Engine Cover Height		mm (ft-in)	2465 (8' 1")		
H: Overall Width of Upperstructure		mm (ft-in)	2490 (8' 2")		
I: Wheelbase		mm (ft-in)	2750 (9' 0")		
J: Swing-center to Rear Axle		mm (ft-in)	1270 (4' 2")		
K: Front Wheel Tread		mm (ft-in)	1875 (6' 2")		
L: Rear Wheel Tread		mm (ft-in)	1875 (6' 2")		
M: Stabilizer Spread		mm (ft-in)	3700 (12' 2")		
N: Max. Raising Height		mm (ft-in)	-		
O: Max. Digging Depth		mm (ft-in)	-		
P: Blade Height		mm (ft-in)	-		
Q: Front Axle to Front of Chassis		mm (ft-in)	1020 (3' 4")		
R: Rear Axle to Rear of Chassis		mm (ft-in)	1080 (3' 7")		
Tire Size		—	10.00-20 14PR		
Swing Speed		min <sup>-1</sup> (rpm)	13.6		
Travel Speed (fast/low/creeper) ※		km/h(mph)	25/6.6/2.0 (15.5/4.1/1.2)		
Gradeability		degree(%)	35 (70)		

NOTE: ※ The specification not matching the local regulation is excluded.

## OPTIONAL ATTACHMENTS AND DEVICES

---

### MAINTENANCE

**Blade Pin (Option) --- every 500 hours**  
**Stabilizer Pin (Option) --- every 500 hours**

Grease all the fittings shown in the figure.

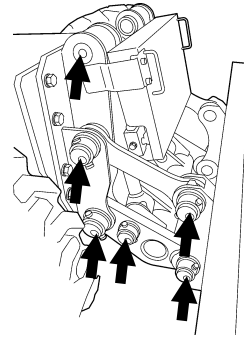

MCBB-13-029

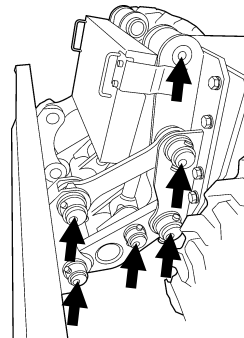

MCBB-13-030

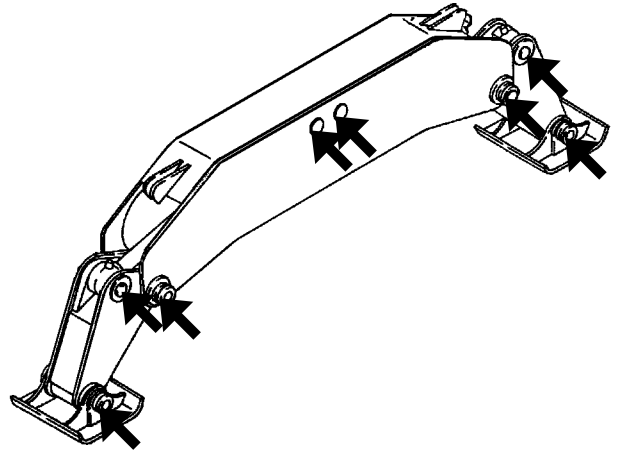

M202-07-044

## OPTIONAL ATTACHMENTS AND DEVICES

---

### REGISTRATION/REGISTRATION CANCELLATION OF ORDINARY OPERATION KEY

Be sure to read the following description beforehand.

**Registration:** Makes the machine controller acknowledge the new ordinary operation keys (black) are correctly set to the corresponding registration key.

**Registration Cancellation:**  
Makes the registration of the ordinary operation key unavailable in case an ordinary operation key is lost, preventing the lost key from being misused. The remaining ordinary operation keys are re-registered so that the lost key registration becomes null.

#### Preparation for Registration

Check that the engine can be started using the registration key (gray). If not, the key used to start the engine might be the one for another machine. Check whether it is correct one.

 **NOTE:** *Registration cannot be performed if the registration key arranged for the machine is not used.*

Check that the engine can be started with the ordinary operation key having been used. In case the engine doesn't start, the key used to start the engine might be the one for another machine. Check whether it is correct one.

 **NOTE:** *Don't attempt to re-register the ordinary operation key having been registered for another machine.*

 **NOTE:**

- *The engine cannot be started with an ordinary operation key newly obtained as a service part unless it is registered.*
- *If the engine is attempted to start more than 5 times per 3 minutes with an incorrect key, the security system is activated, causing the horn to sound.*
- *Turn either the registration key (gray) or the ordinary operation key (black) ON to stop the horn.*

CLICK HERE TO **DOWNLOAD** THE COMPLETE MANUAL

- Thank you very much for reading the preview of the manual.
- You can download the complete manual from: [www.heydownloads.com](http://www.heydownloads.com) by clicking the link below



- Please note: If there is no response to CLICKING the link, please download this PDF first and then click on it.

CLICK HERE TO **DOWNLOAD** THE COMPLETE MANUAL